

LHB SERIES

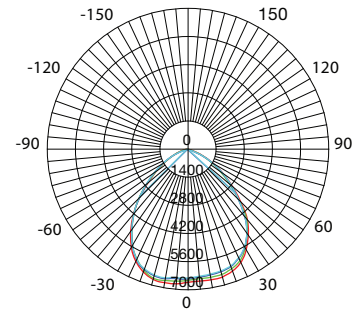

Key Features

- High performance LED chips and driver
- Clear polycarbonate lens with no risk of lamp breaking for safe industry applications
- Optimized aluminum alloy housing design for superior thermal management
- Long service life of >50,000 hours @ L70 lumen maintenance
- Instant light up with no warm up time. No cool down needed before restart
- High mechanical impact resistance and ingress protection rating
- Compact in size and easy for transportation
- Safety compliance, RoHS.

Application

Warehouses, Manufacturing, Large open industrial facilities

Mounting Method

Suspending

Material

Housing: Aluminium alloy
Lens: Polycarbonate

Options

Safety rope
1-10V Dimming
Microwave sensor
Adjustable mounting bracket
Aluminum Reflector

Weight

2.0Kg

TECHNICAL SPECIFICATIONS

IP 65

BH Code	Part No.	Main Voltage	Power	CCT	Beam Angle	Ambient Temp (Ta)	System Lumen
LALHB1509A34	LHB1509A34	85V - 265V AC	150W	6000K - 6500K	90°	-30°C ~ +50°C	22500lm

