



ART. 3010



ART. 3000



TRACCIATO TECNICO COSTRUTTIVO

- Design completamente innovativo.
- Punti presa super ribassati.
- Manico ergonomico.
- Supporto piattello a base ampia.
- Piattello in gomma.
- Ruote in nylon (Art. 3000).
- Dotato di ruote in poliuretano con doppi rulli basculanti anteriori (Art. 3010).
- Dotato di comando di discesa a pedale (Art. 3010).
- Dotato di comando di discesa manuale (Art. 3000).

TECHNICAL AND STRUCTURAL LAY-OUT

- Completely innovative design.
- Very low profile.
- Ergonomic handle.
- Support holder with wide base.
- Rubber covered support.
- Nylon wheels (Art. 3000).
- Equipped with double frontal balancing rolls and rear turning wheels in polyurethane (Art. 3010).
- Foot descent-control (Art. 3010).
- Hand descent-control (Art. 3000).



RELEVÉ TECHNIQUE

- Innovation du design.
- Points de prise surbaissés
- Manche ergonomique.
- Support plateau à base large.
- Plateau caoutchouc.
- Roues en nylon (Art. 3000).
- Avec roues avant en polyuréthane à double rouleaux à bascule (Art. 3010).
- Avec commande de descente à pied (Art. 3010).
- Avec commande de descente manuelle (Art. 3000).

TECHNISCHE UND KONSTRUKTIVE ANGABEN

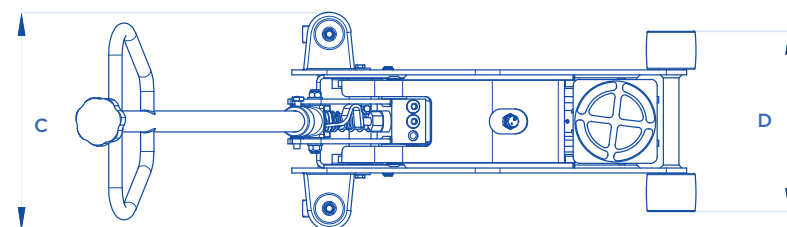
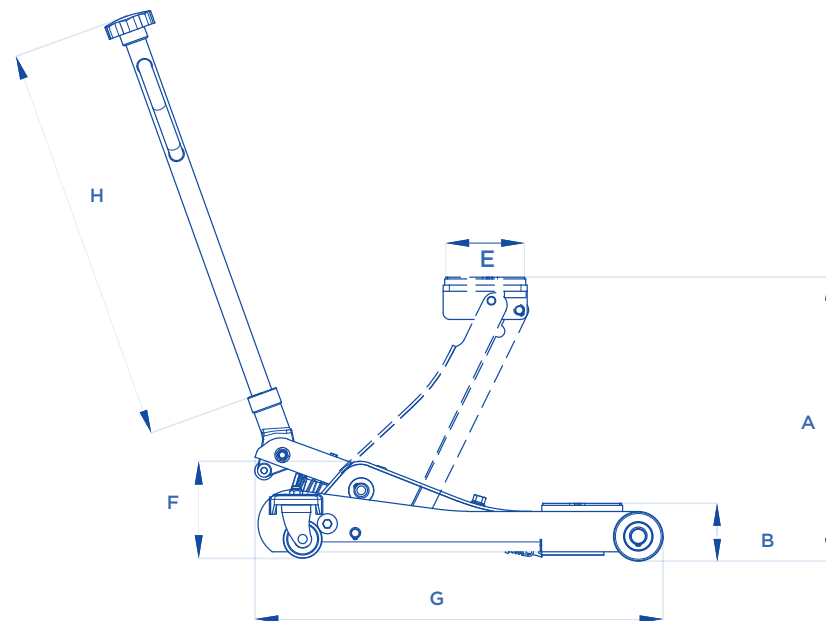
- Völlig innovatives Design.
- Super abgeflachte Aufnahmepunkte.
- Ergonomische Zugstang.
- Tellerstütz mit weiter Grundlage.
- Gummiteller.
- Nylonräder (Art. 3000).
- Mit polyurethan Rädern, von denen kippen doppelten Vorderrollen (Art. 3010).
- Mit Fußhebel Abstiegkontrolle (Art. 3010).
- Mit manueller Abstiegkontrolle (Art. 3000).



ART.		A mm	B mm	C mm	D mm	E mm	F mm	G mm	H mm	
3000	2000 kg	480	95	350	290	130	200	660	810	39
3010	2000 Kg	710	95	480	485	130	210	1000	780	67