



Longer Rope Compact Winch

Model: **CWL-200L**

PN: 372882 220V 372788 220V
 372764 110V 375432 230V
 373200 240V 371313 110V

Introduction

► Feature

- Lifting capacity: 200 kg wire rope top layer
- Lifting height: 69 m for 5 mm x 71 m rope / 98 m for 4 mm x 100 m rope
- Lifting speed: 11 – 16 m/min
- Motor output: 1.2kw x 12A at 110V ; 1.5kw x 7.5A at 220-240V
- Brake: Electromagnetic and mechanical ratchets
- Control: Pendant switch powers the winch

► Unpacking

- Winch assembly 1pc
- Wire rope 5 mm x 71 m with hook 1pc
- Wire rope 4 mm x 100 m with hook for PN : 373200 1pc
- Power lead 1.5 mm² x 3C x 3 m and plug 1pc
- Power lead 2.0 mm² x 3C x 3.4 m and plug for PN : 372764 1pc
- Pendant switch CPB-313 w/cord 1.25 mm² x 6C x 10m 1pc

► Read this manual carefully

You should carefully read and understand this manual before operating it. Careless winch operation may result in personal injury hazards or property damage.

► Information requesting or parts ordering

Please specify the followings information:

- Winch PN
- Serial number
- Part description
- Replacement part number
- Quantity for each part

Installation

Before using the winch, make sure all electrical components have no corrosion or damaged; the environment should be clear and dry.

► Wire rope replacement

- Insert the wire rope into the hole of drum and fix it with a P. T. screw, then press the "UP" button of switch for rotate the drum in the lifting direction.
- Wind the wire rope accurately around the drum, and an irregular winding will cause the load to be swing, thus damaging the wire and reducing the life of the winch.
- When replacing, please refer to the following procedures.
 - *Pull out a R-dowel "D" from the round head pin "C".
 - *Pull out a round head pin "C" from hook body "A".
 - *Put a wire rope "B" into the hole of hook body "A", and insert a round head pin "C" through wire rope and fixture hole of hook body "A".
 - *Insert an R-dowel "D" into the hole of round head pin "C".

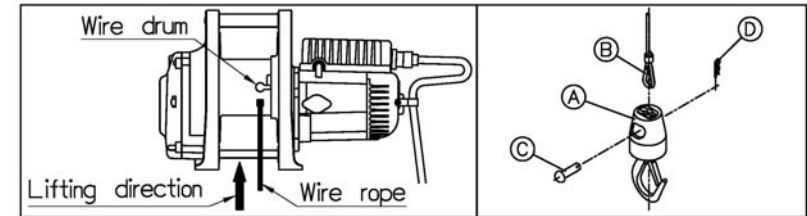

► Wiring Diagram

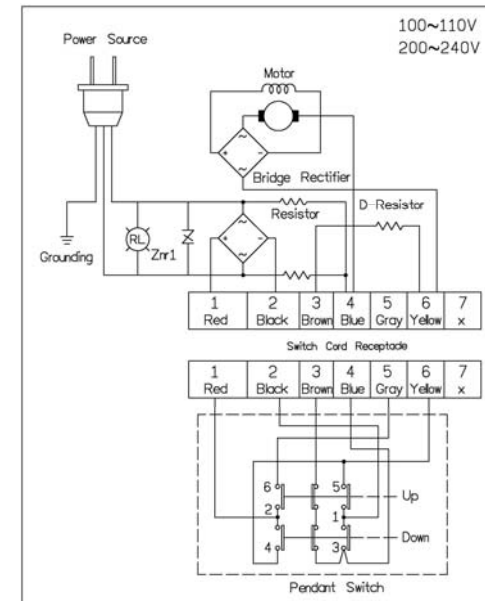

Warning

- The winch is not intended to be used in any manner for the movement or lifting of personnel.
- The lifting capacity shown is based on the top layer of rope on the drum.
- The rope winding on the drum shall remain 5 wraps from the drum.

Parts List

Item No.	Description	Part No.	Qty
1	Gearbox rear cover kit	880546	1
2	Ratchet stopper kit	880547	2
3	2 nd shaft	880548	1
4	3 rd gear kit	880549	1
5	Brake kit	881516	1
6	Tie bar kit	880575	1
7	Tie bar kit A	880576	2
8	Wire rope	880577	1
	Wire rope for PN : 373200	882387	1
9	Weight hook	880384	1
10	Gearbox support rack kit	880555	1
11	Output shaft kit	880556	1
12	Drum kit	881520	1
13	Motor coupling kit	881553	1
14	Motor support rack kit	880558	1
15	Torque shaft kit	881517	1
16	Motor housing kit	880561	1
17	Carbon brush holder kit	880472	1
18	Carbon brush 220~240V	880563	2
	Carbon brush 110V	880473	2
19	Armature core 220V/230V	880976	1
	Armature core 110V	880972	1
	Armature core 240V	880977	1
20	Cooling cover	880564	1
21	Armature winding 220V/230V	880518	1
	Armature winding 110V	880512	1
	Armature winding 240V	880519	1
22	Motor rear cover kit	880566	1
23	Terminal upper cover	880535	1
24	Control panel w/lead & 3 round pins 220V~240V	881232	1
	Control panel w/lead & 2 flat pins 110V	882063	1
	Control panel w/lead & 3 round pins 110V	881231	1
25	Lower plate	880567	1
26	Remote control, CPB-313	880486	1
27	P type hanger kit	881574	1

Winch Assembly

