



ENGLISH

## Datasheet

# 1 Phase Multi-function Energy Meter 100A MID

Energy Meter Measuring Instrument Directive MID Approved,  
1 Phase Multi-function kWh, Din Rail, 100A, Modbus & Pulsed Output

Stock No: 2369293



CE  RoHS MID

[rspro.com](http://rspro.com)

## UK

The 2369293 is a new generation modern design power monitor that will measure and display electrical power quality parameters. It has been engineered to cover most applications (Single Phase networks / Built in Pulsed and RS485 Modbus / Import and Export kWh), replacing the need for several different models of this power meter. The 2369293 works directly connected to a maximum load 100A AC circuit.

- MID B+D Certified
- Certificate Number 0120/SGS0319
- Class B (kWh) EC Directive 2014/32/EU
- Certified for Single Phase
- Certified for Import / Export kWh

As the demand for MID certified meters has increased, we have obtained annex B and D of the EC Directive 2014/32/EU. This power meter has been tested and certified for single phase networks and import and export active energy (kWh).

The 2369293 is produced to the highest quality and utilizes the latest microprocessor and technology. It has a backlit display and 16 different measuring parameters. With built in pulsed out- puts and RS485 Modbus RTU it is fully compatible for integration with BMS and remote monitoring systems. This model does not require Current Transformers as it is directly connected to single phase 100A AC circuits.

### Parameters

- Phase to Neutral Voltage (V)
- Phase Current (A)
- Frequency (Hz)
- Power Factor (PF)
- Active Power (kW)
- Reactive Power (kVAr)
- Apparent Power (kVA)
- Import Active Energy (kWh)
- Export Active Energy (kWh)
- Total Active Energy (kWh)
- Import Reactive Energy (kVArh)
- Export Reactive Energy (kVArh)
- Total Reactive Energy (kVArh)

## Specifications

### Measured Parameters

The unit can monitor and display the following parameters of a single phase two wire (1p2w) system.

### Voltage and Current

- Phase to neutral voltage 100 to 289V AC
- Phase current 0 to 120A AC (direct measurement)

### Power factor and Frequency and Max. Demand

- Frequency in Hz
- Instantaneous power:
- Power 0 to 3600 MW
- Reactive power 0 to 3600 MVA
- Volt-amps 0 to 3600 MVA
- Maximum demanded power since last Demand reset Power factor

### Interfaces for External Monitoring

Three interfaces are provided:

- RS485 communication channel that can be programmed for Modbus RTU protocol
- Pulse output indicating real-time measured energy.(configurable)
- Pulse output 3200imp/kW h (not configurable)

The Modbus configuration (baud rate etc.) and the pulse relay output assignments (kW/kVArh, import/export etc.) are configured through the set-up screens

### Pulse Output

The meter provides two pulsed outputs, both pulsed outputs are passive type. The first pulsed output is configurable. The pulsed output can be set to read total / import / export/ kWh /kVArh. The pulse constant can be set to generate 1 pulse per: 0.001(default) /0.01/0.1/1kWh/kVArh. The second pulsed output is non-configurable. It is fixed to read total kWh. Opto-coupler with potential free SPST-NO Contact (Contact range 5-27VDC / Max current input: Imin 2mA and Imax 27mA DC).

Rate can be set to generate 1 pulse per:

0.001 = 1 Wh/VArh (default)

0.01 = 10 Wh/VArh

0.1 = 100 Wh/VArh

1 = 1 kWh/kVArh

Pulse width 200/100/60 ms.



## RS485 Output for Modbus RTU

For Modbus RTU, the following RS485 communication parameters can be configured from the set-up menu:

Baud rate 2400, 4800, 9600

Parity none (default) / odd / even Stop bits 1 or 2

RS485 network address nnn – 3-digit number, 1 to 247  
Modbus™ Word order Hi/Lo byte order is set automatically to normal or reverse. It cannot be configured from the set-up menu.

## Energy Measurements

Imported/Exported active energy	0 to 9999999.9 kWh
Imported/Exported reactive energy	0 to 9999999.9 kVARh
Total active energy	0 to 9999999.9 kWh
Total reactive energy	0 to 9999999.9 kVARh

## Auxiliary Supply

This unit is self-supplied from the connected phase therefore a separate auxiliary supply is not required.

## Measured Inputs

Voltage inputs through 2-way fixed connector with 25mm<sup>2</sup> stranded wire capacity. single phase two wire(1p2w).

Nominal Voltage Input	(Ph+N) 100 to 289V
Max Continuous Voltage	120% of nominal
Nominal Input Current	0,5-10(100)A AC rms
Max Continuous Current	120% of nominal
Frequency	45-65Hz

## Accuracy

Voltage	0.5% of range maximum
Current	0.5% of nominal
Frequency	0.2% of mid-frequency
Power factor	1% of unity (0.01)
Active power (W)	±1% of range maximum
Reactive power (VAR)	±1% of range maximum
Apparent power (VA)	±1% of range maximum
Active energy (Wh)	Class 1 IEC 62053-21
Reactive energy (VARh)	±1% of range maximum
Response time to step input	1s, typical, to >99% of final reading, at 50 Hz.
Response time to step input	1s, typical, to >99% of final reading, at 50 Hz.

## Reference Conditions of Influence Quantities

Influence Quantities are variables that affect measurement errors to a minor degree. Accuracy is verified under nominal value (within the specified tolerance) of these conditions.

Ambient temperature	23°C ±1°C
Input waveform	50 or 60Hz ±2%
Input waveform	Sinusoidal (distortion factor < 0.005)
Auxiliary supply voltage	Nominal ±1%
Auxiliary supply frequency	Nominal ±1%
Auxiliary supply waveform (if AC)	Sinusoidal (distortion factor < 0.05)
Magnetic field of external origin	Terrestrial flux

## Environment

Operating temperature	-25°C to +55°C*
Storage temperature	-40°C to +70°C*
Relative humidity	0 to 95%, non-condensing
Altitude	Up to 3000m
Warm up time	1 minute
Vibration	10Hz to 50Hz, IEC 60068-2-6, 2g
Shock	30g in 3 planes

\*Maximum operating and storage temperatures are in the context of typical daily and seasonal variation.



## Mechanics

DIN rail dimensions	36 x 99mm (WxH) per DIN 43880
Mounting	DIN rail (DIN 43880)
Sealing	IP51 indoor
Material	Self-extinguishing UL 94 V-0

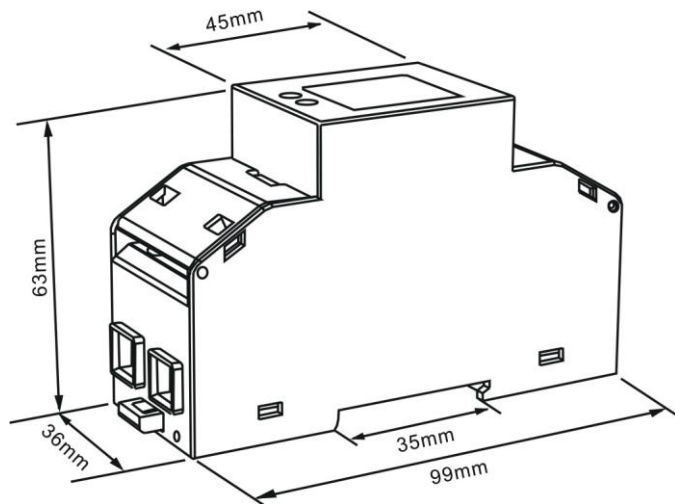

## Installation

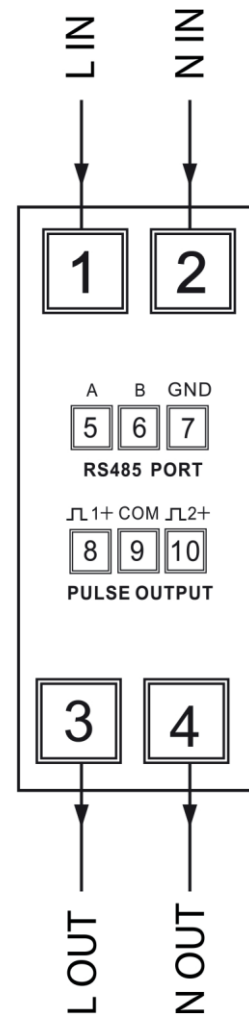

Specifications are subject to change without notice.