

Circuits from the Lab[®] Reference Designs

Circuits from the Lab[®] reference designs are engineered and tested for quick and easy system integration to help solve today's analog, mixed-signal, and RF design challenges. For more information and/or support, visit www.analog.com/CN0536.

Devices Connected/Referenced

LTC6906	Micropower, 10 kHz to 1 MHz Resistor Set Oscillator
LTC6994	TimerBlox: Delay Block/Debouncer
LTC1540	Nanopower Comparator with Reference
LTC1441	Ultralow Power Single/Dual Comparator

Geiger Counter Circuit with Adjustable High Voltage Power Supply

EVALUATION AND DESIGN SUPPORT

- ▶ Circuit Evaluation Boards
 - ▶ [CN0536 Circuit Evaluation Board \(EVAL-CN0536-ARDZ\)](#)
 - ▶ [Ultralow power, Cortex-M3 Arduino form factor compatible development board \(EVAL-ADICUP3029\)](#)
- ▶ Design and Integration Files
 - ▶ [Schematics, Layout Files, Bill of Materials](#)

CIRCUIT FUNCTIONS AND BENEFITS

Radiation monitoring is an essential part of ensuring health and safety in and around nuclear energy production facilities, marine propulsion applications, contaminated environments, medical facilities, and other industrial settings where radioactive material may be present.

There are various passive and active methods of measuring instantaneous radiation intensity and total radiation dose. The simplicity, low cost, and reliability of the Geiger-Mueller counter make it a compelling choice as a primary radiation measurement device, or as a secondary measurement in conjunction with other methods.

The circuit shown in [Figure 1](#) is designed for use with Geiger counter radiation detectors (GM tube not included) is in an Arduino

shield form factor compatible with 3 V and 5 V platform boards. The bias power supply is adjustable from 280 V to 500 V, allowing use with a wide range of Geiger-Mueller tubes; an SI-29BG tube is used as an example.

Audible and light emitting diode (LED) event indicators provide a qualitative measure of radiation intensity, and the conditioned event pulse is routed to an Arduino interrupt pin for quantitative measurement and long-term datalogging.

The solution is adaptable to a local physical display (liquid crystal display (LCD), organic LED (OLED), and so on) or wired data connection using the universal asynchronous receiver and transceiver (UART) interface of the platform board. Wireless connectivity via Bluetooth or WiFi provides electrical isolation and simplifies remote monitoring and applications that aggregate data from multiple sensors.

The high voltage power supply is a unique architecture centered around a micropower comparator with built in reference. Hysteresis regulation reduces the quiescent current consumption to microamps, and a second power-good comparator detects fault conditions, making this circuit ideal for battery-powered, long-term monitoring applications.

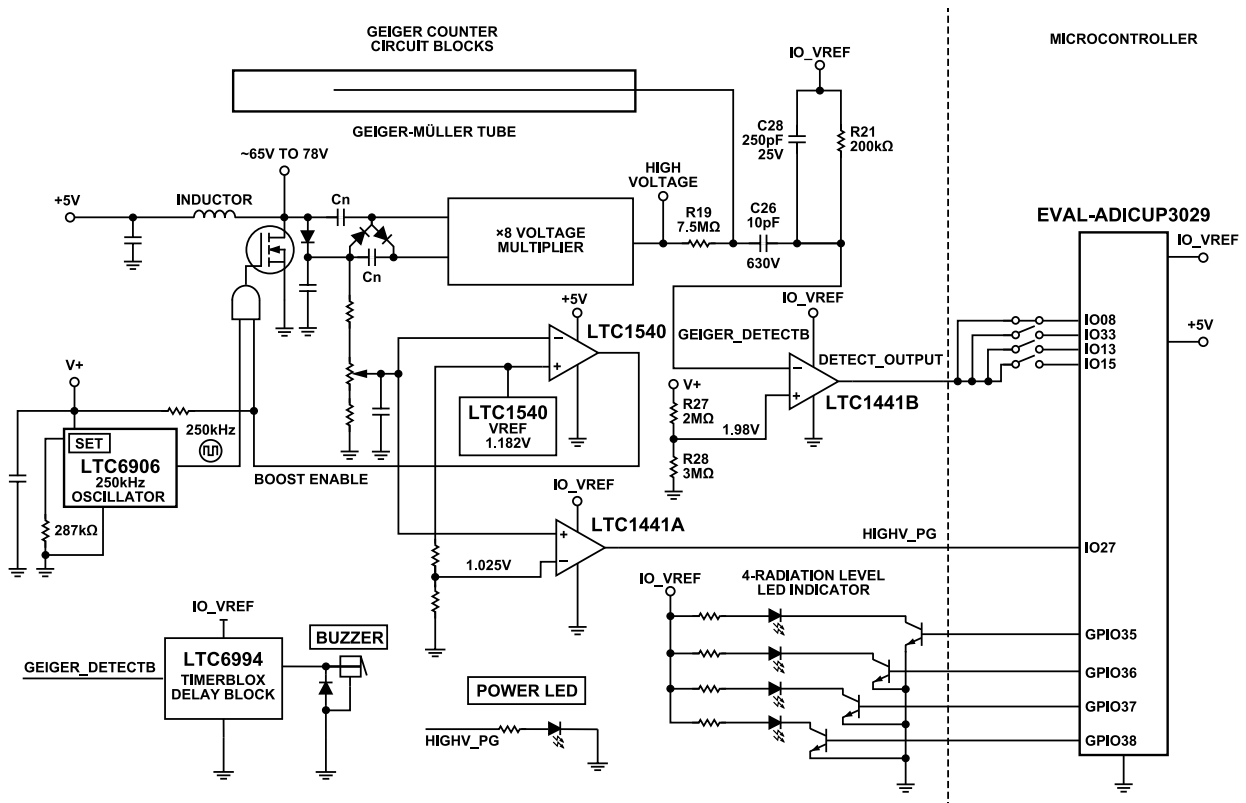

Figure 1. EVAL-CN0536-ARDZ Block Diagram

001

CIRCUIT DESCRIPTION

GEIGER-MULLER TUBE PRINCIPLES OF OPERATION

The Geiger-Muller tube is an ionizing radiation detector that is sensitive to alpha, beta, gamma, and x-ray radiation. While it cannot discriminate between radiation types, its sensitivity, simplicity, and reliability make it a practical choice in a wide range of radiation monitoring applications, either alone or in conjunction with other sensors.

Geiger-Muller tubes are commonly biased to a voltage ranging from 250 V to 500 V with a near zero current drawn when no radiation events are taking place. Several typical Geiger-Muller tubes are shown in Figure 2.



Figure 2. Geiger-Muller Sensor Tubes

When an ionized particle enters the tube, ion pairs consisting of a free electron and a positively charged gas molecule are created. Electrons accelerate toward the anode, creating additional ion pairs, causing an avalanche of additional electrons. Electrically, this effect produces a momentary low impedance path between the anode and the cathode that can be detected as a voltage pulse across an external resistance. The external resistance is also necessary to allow the anode to the cathode voltage to drop to a point where the avalanche stops (known as quenching).

The output signal can be measured at either the cathode (see Figure 3) or anode (see Figure 4).

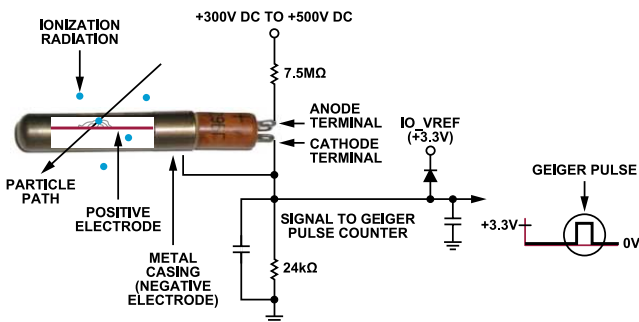

Figure 3. Geiger-Muller Tube with Pulse Signal at Cathode

While taking the signal from the cathode avoids the need for a high voltage, level shifting capacitor, it is more sensitive to electrical

noise because the cathode impedance to ground is relatively high. The CN0536 takes the signal from the anode (see Figure 4) with the cathode grounded to minimize susceptibility to noise.

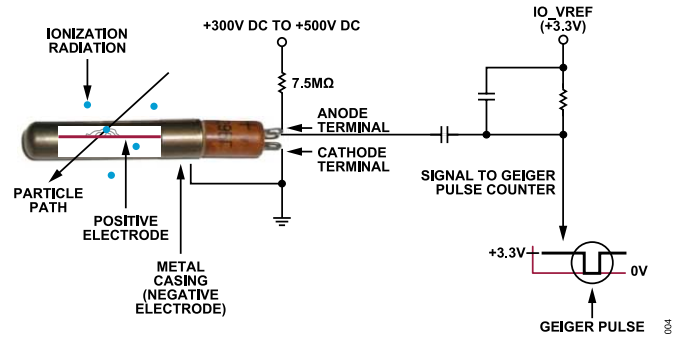

Figure 4. Geiger-Muller Tube with Pulse Signal at Anode

GEIGER PULSE DETECTION

Figure 5 shows the LTspice® schematic of the Geiger-Mueller pulse level shifting and detection circuitry.

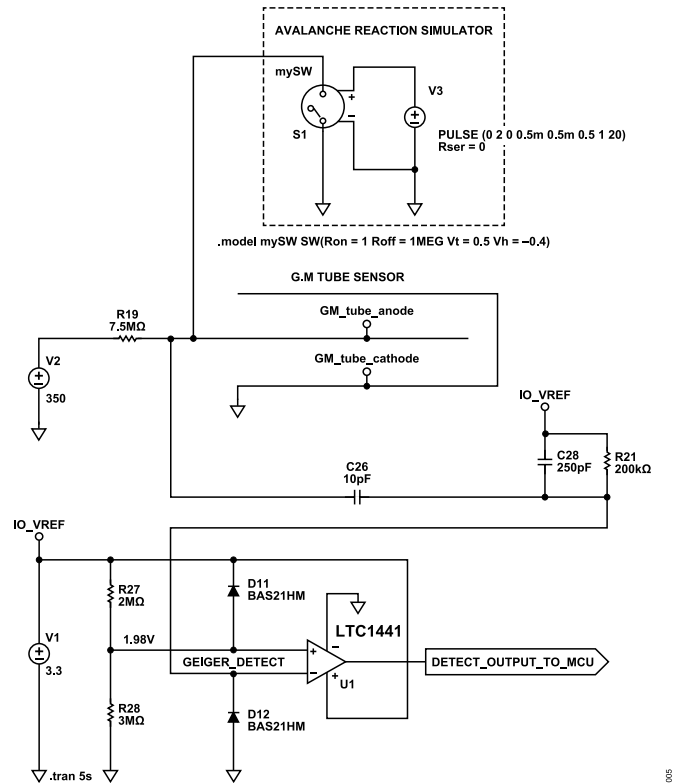

Figure 5. LTspice Schematic of the Geiger Pulse Shifting and Detection Circuitry

When no radiation events are occurring, the anode is biased at 350 V. C28 and C26 form a capacitive voltage divider, whose output is biased at IO_VREF through R21. When an event occurs, the anode is momentarily pulled toward ground potential, producing a 400 V negative going step. When the output of the attenuator drops to less than the 1.98 V threshold set by R27 and R28, the output of the LTC1441 comparator drives high. The comparator output is routed to an interrupt pin on the platform board, such that

software can respond to the event. Figure 6 shows the attenuator and comparator outputs for a typical radiation event.



Figure 6. Geiger-Mueller Output Pulse Detection and LTC1441 Output Pulse

HIGH VOLTAGE SUPPLY

The Geiger-Mueller bias is provided by the micropower, high voltage power supply shown in Figure 7. The circuit is a fixed frequency, fixed 50% duty cycle, nonsynchronous boost converter followed by a Cockcroft-Walton multiplier, with hysteretic voltage mode control.

An LTC6906 resistor-programmable oscillator is configured to produce a 250 kHz, 50% duty cycle square wave. An AND gate buffers this clock signal and functions as a gate driver for the boost power metal-oxide semiconductor field effect transistor (MOSFET). Because the LTC6906 draws its full 12.5 μA supply current whenever power is applied, the converter is enabled and disabled by simply switching the V+ supply of the LTC6906 on and off. The AND gate ensures that the switching FET is either off or fully enhanced, even as the supply voltage of the LTC6906 is ramping up or down.

Voltage feedback is taken from the output of the first multiplier stage, which greatly reduces power dissipation in the feedback divider at the expense of a slight reduction in load regulation. Figure 7 is the LTspice schematic simulation of the high voltage power supply that is included in the design support package.

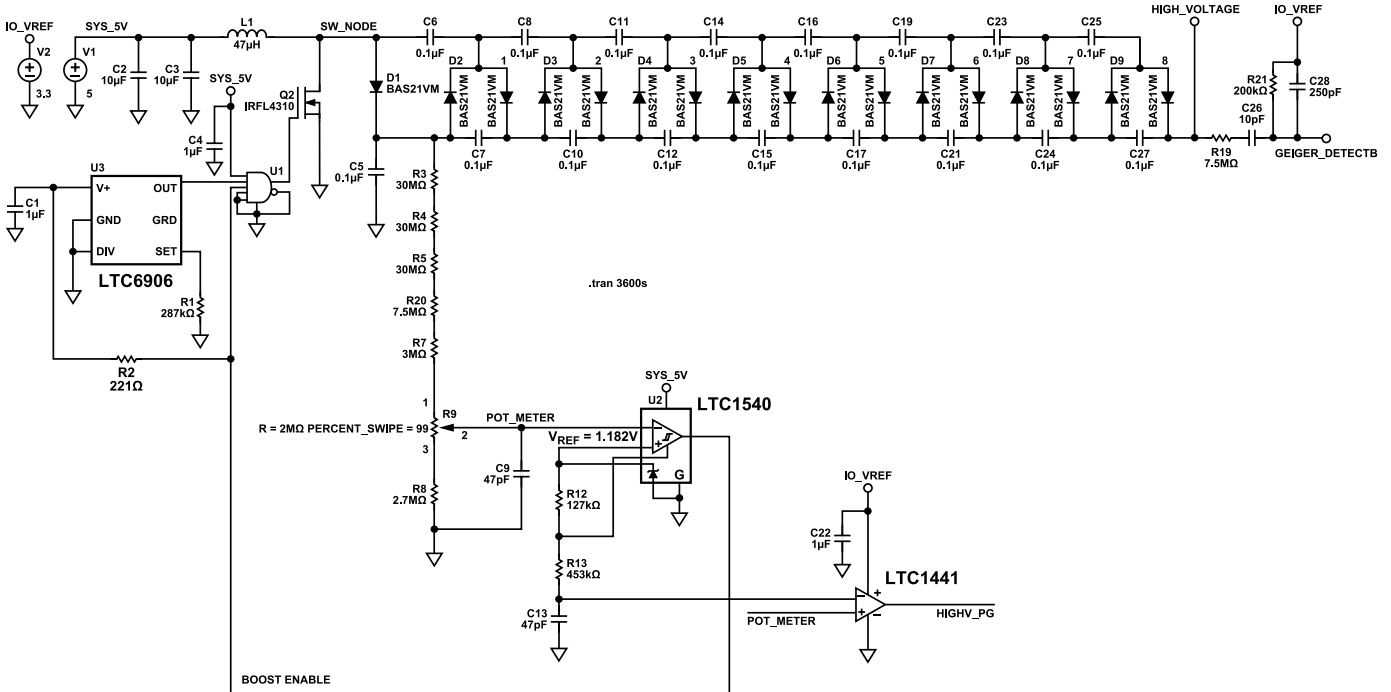

Figure 7. Micropower High Voltage Power Supply

HIGH VOLTAGE GENERATION (280 V TO 500 V)

When power is first applied, the feedback voltage is at ground potential, driving the output of U1 high, which in turn powers up the LTC6906, and the boost stage begins switching at 350 kHz, 50% duty cycle. L1, Q2, D1, and C5 form a conventional nonsynchronous boost converter, and once the voltage at C5 rises to 64 V, U1 trips off. The output voltage slowly decays to 55 V, determined by the hysteresis of U2, and the cycle begins again. The initial turn-on transients are shown in Figure 8 and Figure 9.



Figure 8. Turn-On Transient at a Time Scale of 2 ms



Figure 9. Turn-On Transient at a Time Scale of 100 ms

The output voltage is set to 400 V nominal and maintained between 390 V and 410 V. The duty cycle is low, approximately 0.1%, with a 200 μ s burst every 600 ms. This results in an average current consumption of 33 μ A. Probing the output of the multiplier is challenging because even the 10 M Ω impedance of a typical scope probe can affect the operation of the circuit. However, probing earlier stages illustrates the principle. Figure 10 and Figure 11 show the voltage at C11 at the output of the second multiplier stage, while Figure 12 and Figure 13 show the pulse switching of the 100 V, N-channel, enhancement mode MOSFET Q2 driven to its gate terminal by the 350 kHz switching frequency using a combination of an AND gate and the LTC6906 frequency clock generator.

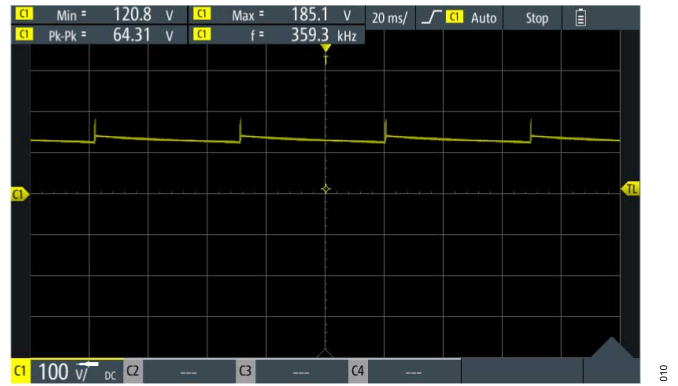

Figure 10. Hysteretic Regulation Measured at C11 at a Time Scale of 20 ms

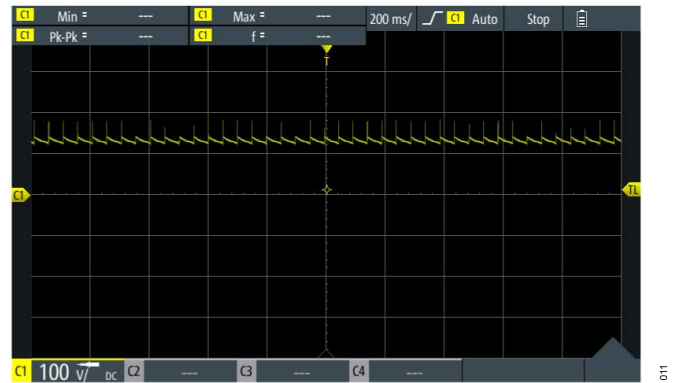

Figure 11. Hysteretic Regulation Measured at C11 at a Time Scale of 200 ms

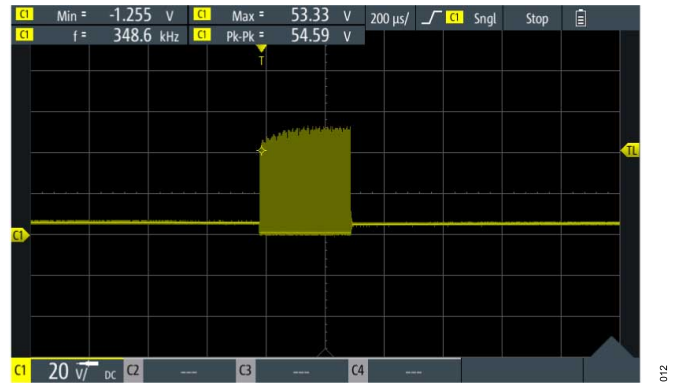

Figure 12. Boost Pulses at MOSFET Q2 Drain Terminal at 200 μ s



Figure 13. Boost Pulses at MOSFET Q2 Drain Terminal at 5 μs

GEIGER PULSE VISUAL/AUDIBLE INDICATORS

The 18 μs output pulse from the Geiger-Mueller event detector circuit is too short to reliably generate a visual indication (LED) or audible click from a buzzer. An LTC6994 programmable delay block/debouncer is configured with a master timebase (t_{MASTER}) of 2.5 μs, N divider value of 512, and a delay falling edge (POL) = 1. This results in a 1.28 ms pulse to an LED indicator and buzzer, producing an easily visible flash and audible click. Figure 14 shows the detailed schematic of the timer block delay.

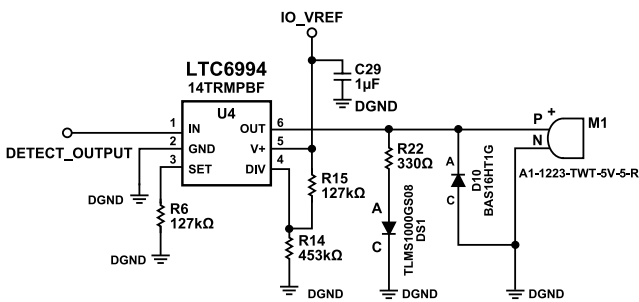

Figure 14. Timer Block LTC6994 Click Sound Generator

$$t_{DELAY} = (N_{DIV} \times R_{SET}) / 50k\Omega \times 1\mu s \quad (1)$$

where:

$$N_{DIV} = 1, 8, 64, \dots, 2^{21} \quad (2)$$

$$R_{SET} \text{ is } R6 \text{ (see Figure 14)} \quad (3)$$

HIGH VOLTAGE POWER GOOD

The second half of the LTC1441 comparator functions as a high voltage power-good indicator (see Figure 15).

The circuit uses the REF output (V_{REF}) of the LTC1540 as a reference, which is the same reference that is used to set the regulation voltage. If the potentiometer wiper falls to less than the reference voltage, the comparator output asserts, indicating a loss of regulation.

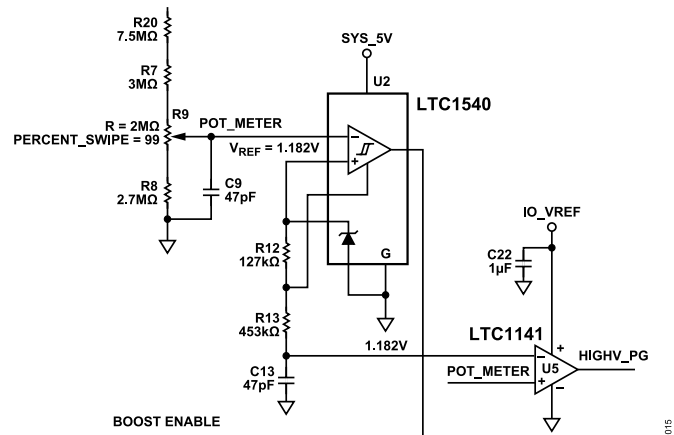

Figure 15. High Voltage Power-Good Indicator

COMMON VARIATIONS

The output pulse of the Geiger-Mueller tube can be taken from the cathode (outer shell) to avoid the need for a high voltage capacitor. However, taking the output pulse this way is more sensitive to electrical interference because the cathode acts as an antenna.

For long-term, battery-powered applications, the LTC6994 and power LED can be omitted from the circuit to minimize quiescent current.

CIRCUIT EVALUATION AND TEST

The following section outlines the procedure for bringing up the CN0536. For complete details on the hardware and software set-ups, see the [CN0536 user guide](#).

SYSTEM BLOCK DIAGRAM

Figure 16 shows the system block diagram.

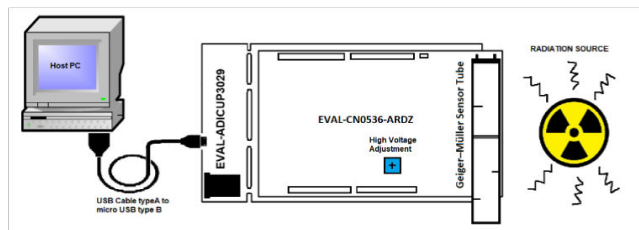

Figure 16. The EVAL-CN0536-ARDZ Combined with the EVAL-ADICUP3029

EQUIPMENT NEEDED

The following equipment is needed:

- ▶ The [EVAL-CN0536-ARDZ](#) with GM tube installed
- ▶ The [EVAL-ADICUP3029](#)
- ▶ 280 V to 500 V Geiger-Mueller tube, such as SI-29BG
- ▶ A microUSB cable
- ▶ A host computer with a serial terminal program, such as Tera Term or PuTTY
- ▶ A safe radiation source, for example, the Flinn Scientific AP8795 1 μ Ci Cobalt-60 gamma source or similar
- ▶ The [ADuCM3029_demo_cn0536_uart.hex](#) software file

GETTING STARTED

To set up the EVAL-CN0536-ARDZ and the associated software, use the following steps:

1. Connect the EVAL-CN0536-ARDZ on top of the [EVAL-ADICUP3029](#) platform board as shown in [Figure 17](#).

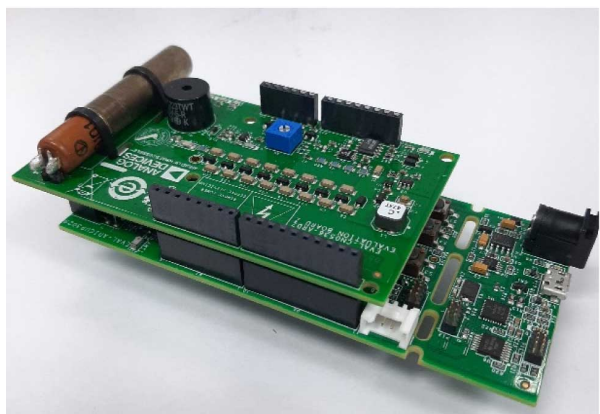

Figure 17. EVAL-CN0536-ARDZ and EVAL-ADICUP3029 Connection

2. Connect the [EVAL-ADICUP3029](#) to the PC using the microUSB cable provided.

3. From the PC, drag and drop the prebuilt [ADuCM3029_demo_cn0536_uart.hex](#) file onto the DAPLINK drive.
4. Open the serial terminal program (for example, Tera Term or PuTTY)
5. Connect the EVAL-ADICUP3029 by using the COM port it was assigned to set the baud rate to 115200 (see [Figure 18](#)).

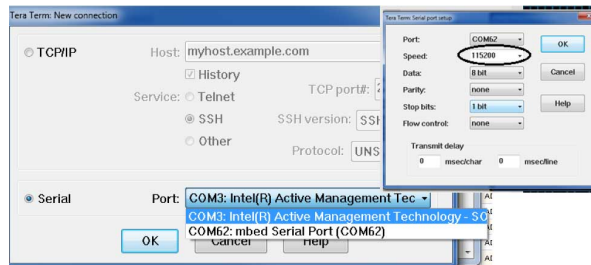

Figure 18. Using Tera Term as Serial Monitor With Baud Rate Set to 115200

6. Place the radioactive source near the Geiger-Mueller tube and observe the terminal.

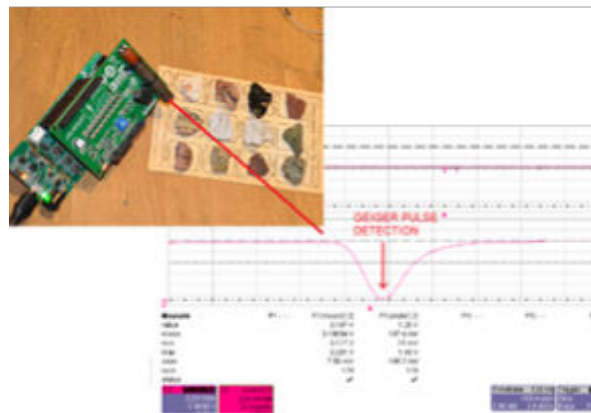

Figure 19. EVAL-CN0536-ARDZ Connected to the EVAL-ADICUP3029 Next to the Uranium Ore Sample

Total count:	7;	CPM:	3;	us_per_hour:	0.03
Total count:	10;	CPM:	5;	us_per_hour:	0.05
Total count:	14;	CPM:	8;	us_per_hour:	0.08
Total count:	15;	CPM:	9;	us_per_hour:	0.09
Total count:	18;	CPM:	12;	us_per_hour:	0.12
Total count:	18;	CPM:	12;	us_per_hour:	0.12
Total count:	20;	CPM:	13;	us_per_hour:	0.13
Total count:	23;	CPM:	13;	us_per_hour:	0.13
Total count:	25;	CPM:	11;	us_per_hour:	0.11
Total count:	25;	CPM:	10;	us_per_hour:	0.10
Total count:	26;	CPM:	8;	us_per_hour:	0.08
Total count:	27;	CPM:	9;	us_per_hour:	0.09
Total count:	28;	CPM:	8;	us_per_hour:	0.08
Total count:	28;	CPM:	5;	us_per_hour:	0.05
Total count:	31;	CPM:	6;	us_per_hour:	0.06
Total count:	34;	CPM:	9;	us_per_hour:	0.09
Total count:	37;	CPM:	11;	us_per_hour:	0.11
Total count:	39;	CPM:	12;	us_per_hour:	0.12
Total count:	41;	CPM:	13;	us_per_hour:	0.13
Total count:	43;	CPM:	15;	us_per_hour:	0.15
Total count:	45;	CPM:	14;	us_per_hour:	0.14
Total count:	46;	CPM:	12;	us_per_hour:	0.12
Total count:	48;	CPM:	11;	us_per_hour:	0.11
Total count:	48;	CPM:	9;	us_per_hour:	0.09

Autoscroll Show timestamp

020

Figure 20. Geiger-Mueller Detection Pulse from an Uranium Ore Sample

LEARN MORE[CN0536 Design Support Package](#)[CN0536 User Guide](#)[CN0536 Software Reference Design](#)**DATA SHEETS AND EVALUATION BOARDS**[LTC6906 Data Sheet](#)[LTC6994 Data Sheet](#)[LTC1540 Data Sheet](#)[LTC1441 Data Sheet](#)[LT6906 Evaluation Kit \(DC2073B-H\)](#)[LTC6994 Evaluation Kit \(DC1562B-K\)](#)[LTC1540 Evaluation Kit \(DC600A\)](#)**REVISION HISTORY****08/24—Rev. 0 to Rev. A**

Changes to Document Title.....	
Changes to Circuit Functions and Benefits section.....	1
Changes to Equipment Needed section.....	7

04/21—Revision 0: Initial Version**ESD Caution**

ESD (electrostatic discharge) sensitive device. Charged devices and circuit boards can discharge without detection. Although this product features patented or proprietary protection circuitry, damage may occur on devices subjected to high energy ESD. Therefore, proper ESD precautions should be taken to avoid performance degradation or loss of functionality.

(Continued from first page) Circuits from the Lab circuits are intended only for use with Analog Devices products and are the intellectual property of Analog Devices or its licensors. While you may use the Circuits from the Lab circuits in the design of your product, no other license is granted by implication or otherwise under any patents or other intellectual property by application or use of the Circuits from the Lab circuits. Information furnished by Analog Devices is believed to be accurate and reliable. However, Circuits from the Lab circuits are supplied "as is" and without warranties of any kind, express, implied, or statutory including, but not limited to, any implied warranty of merchantability, noninfringement or fitness for a particular purpose and no responsibility is assumed by Analog Devices for their use, nor for any infringements of patents or other rights of third parties that may result from their use. Analog Devices reserves the right to change any Circuits from the Lab circuits at any time without notice but is under no obligation to do so.

