



Series E08 | Split crossbar along the outer radius
Series Z08 | Split crossbar along the inner radius

Standard	Split crossbar along outer radius	Split crossbar along inner radius	Bi [mm]	Ba [mm]	R Bending radii [mm]	Weight [kg/m]
E08.10	.R.0 ¹⁾	Z08.10 .R.0 ¹⁾	10	18,2	025* 028 038 048	≈ 0,21
E08.16	.R.0 ²⁾	Z08.16 .R.0 ²⁾	16	24,2	025* 028 038 048	≈ 0,24
E08.20	.R.0	Z08.20 .R.0	20	28,2	025* 028 038 048	≈ 0,25
E08.30	.R.0	Z08.30 .R.0	30	38,2	025* 028 038 048	≈ 0,28
E08.40	.R.0	Z08.40 .R.0	40	48,2	025* 028 038 048	≈ 0,31
E08.50	.R.0	Z08.50 .R.0	50	58,2	025* 028 038 048	≈ 0,37

1) Crossbars do not overlap. Gap = 5,5 mm / 2) Crossbars do not overlap. Gap = 4,0 mm

*Radius available upon request, please consult igus® for delivery time

Supplement Part No. with required radius (R). Example: E08.10.028.0

Ba: pin dimension approx. 0,3 - 0,5 mm wider.

Dimensions

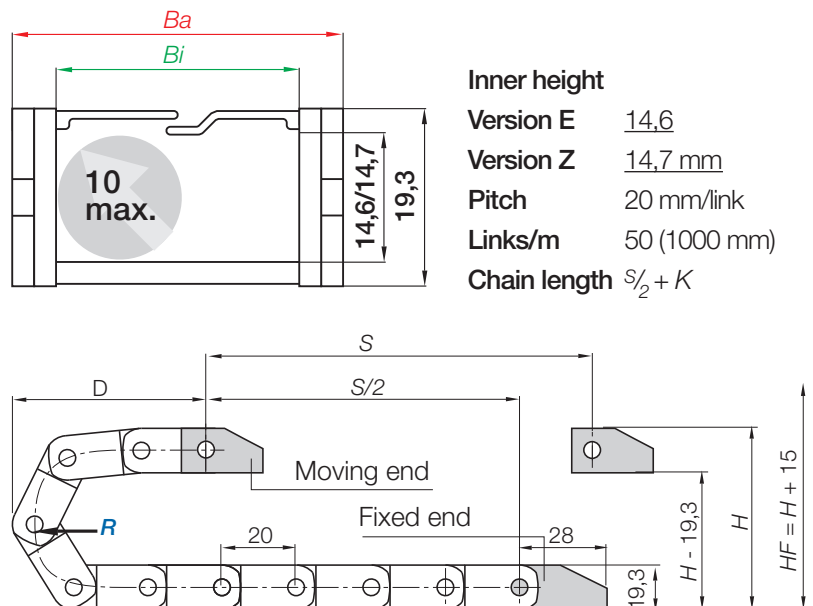
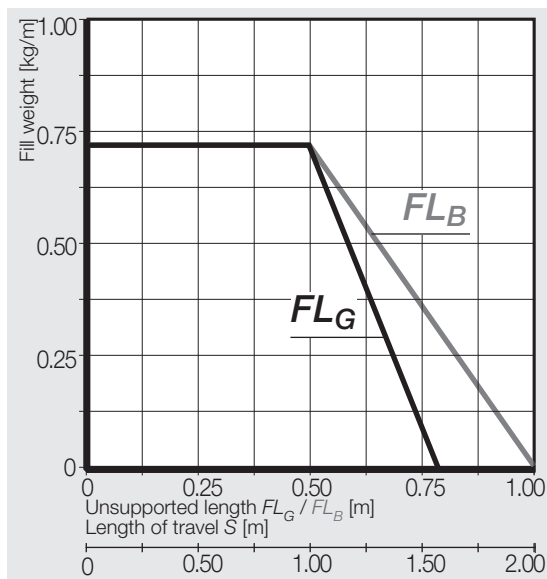

Inner height
Version E 14,6
Version Z 14,7 mm
Pitch 20 mm/link
Links/m 50 (1000 mm)
Chain length $S/2 + K$

R	025*	028	038	048
H	69	75	95	115
D	65	68	78	88
K	120	130	160	195

The required clearance height: $H_F = H + 15$ mm (with 0,3 kg/m fill weight)

*Radius available upon request, please consult igus® for delivery time

Mounting brackets, polymer one-piece | locking | More features ► www.igus.eu/08

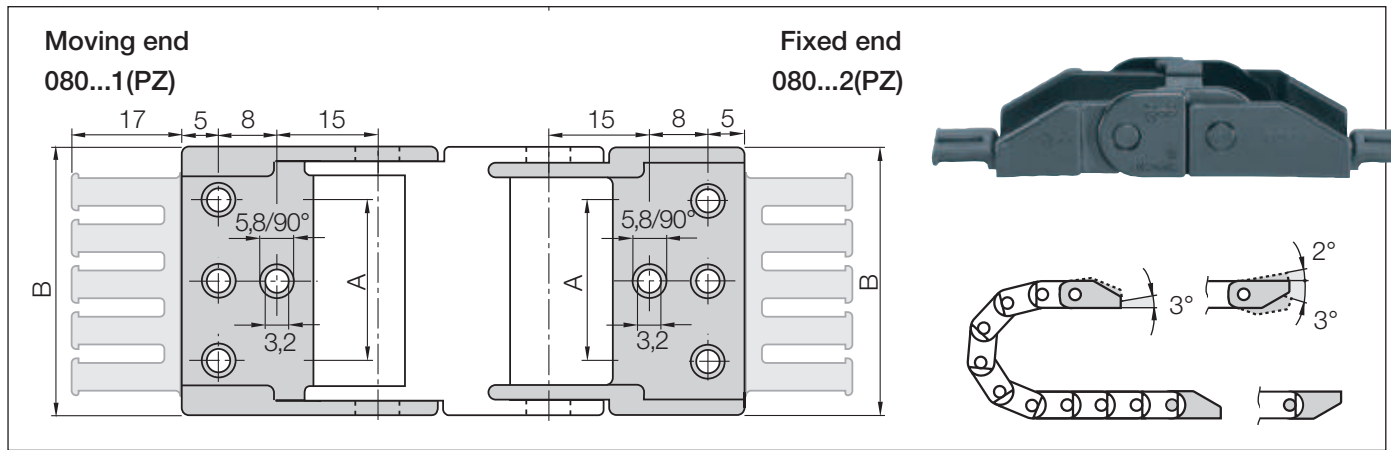

Width Index	Standard	Part No. full set with tie-wrap plates	Part No. full set without tie-wrap plates	Dim. A [mm]	Dim. B [mm]	Number of teeth
.10.	►	080.10. 12PZ	080.10. 12	-	18,2	1
.16.	►	080.16. 12PZ	080.16. 12	-	24,2	2
.20.	►	080.20. 12PZ	080.20. 12	-	28,2	2
.30.	►	080.30. 12PZ	080.30. 12	22	38,2	3
.40.	►	080.40. 12PZ	080.40. 12	32	48,2	4
.50.	►	080.50. 12PZ	080.50. 12	42	58,2	5

Material mounting bracket - igumid G, temperature: -40° up to +120° C, VDE 0304 IIC UL94-HB

Drilling pattern for width index: 080.10. - 080.20. center bores only / 080.30. - 080.50. all bores (see figure above)

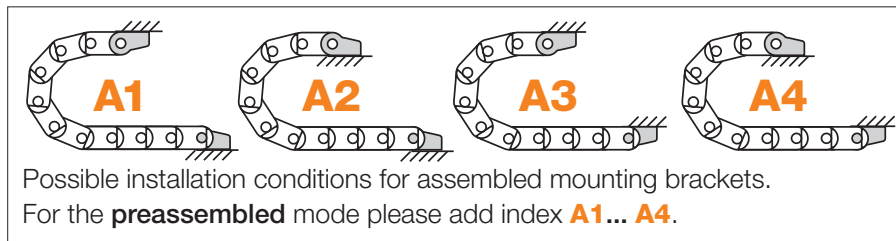

Part No. structure

080.10. 12 PZ A2

- A... must be indicated on preassembled configurations
- With strain relief tie-wrap plates
- Full set**
- Mounting bracket for selected width index