

# LF70ES LED Flood Light

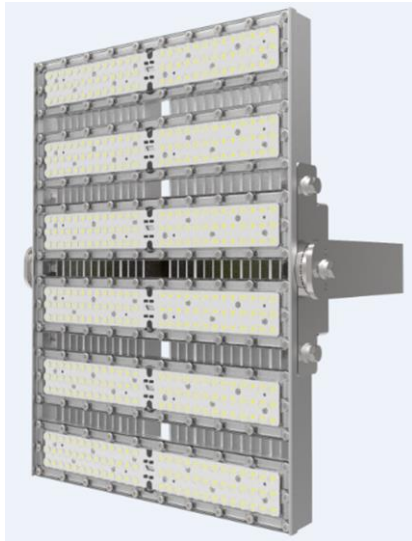

## Products description and application

LF70 series LED flood light is specially designed for the harsh environment application of Port, Mine site etc. Product has high luminous efficacy, C4 level anti-corrosion capacity and 5G anti-vibration ability. Standard: IEC60068-1\IEC60068-2\IEC60529\IEC62262\EN55015 Certificate: CE

## Features

- Module design, flexible combination
- High efficient heat dissipation structure design
- Light-weight design, easy installation
- Series and parallel electric circuit design
- PWM/0-5V/0-10V/time control, dimming control are optional

## General Specifications

Electrical		Mechanical	
Rated voltage	AC100V~AC240V	Body material	Aluminum alloy
Frequency	50Hz~60Hz	Cover material	PC
Rated power consumption	600W/400W/300W/200W/150W	Safety wire material	Stainless steel
Power factor	>0.9	Operating temperature	Ta-30°C ~ +60°C (overheat protection)
Lightning surge	IEC61000-4-5: 2005±2KV	IP Rate	IEC60529 IP67
Electrostatic discharge	IEC61000-4-2: 2001±6KV	Anti-vibration	IEC60068-2-6 5G
EMC	IEC61000-4-3 CLASS 3 IEC61000-4-4 CLASS 4 IEC61000-4-6 CLASS 3 EN55015	IK rate	IEC62262 IK08
		Salt spray rate	ISO9227 720H/ C5-M
		Body color	Silver
		Weight	75W /4.0 Kg 150W /5.0 Kg 200W /8.5Kg 300W /11.5Kg 400W /15.0Kg 600W /21.0 Kg
Photometric			
LEDs life span	≥50000h		
Color temperature	Cold white: 5500K-6000K	Warm white:2700K	
Lumen per Watt	Cold white: 140 lm/w	Warm white:125 lm/w	
CRI	Cold white: Ra≥70	Warm white: Ra≥80	
Beam angle	15° / 25° / 60°		

# LF70ES LED Flood Light



## Mounting dimensions

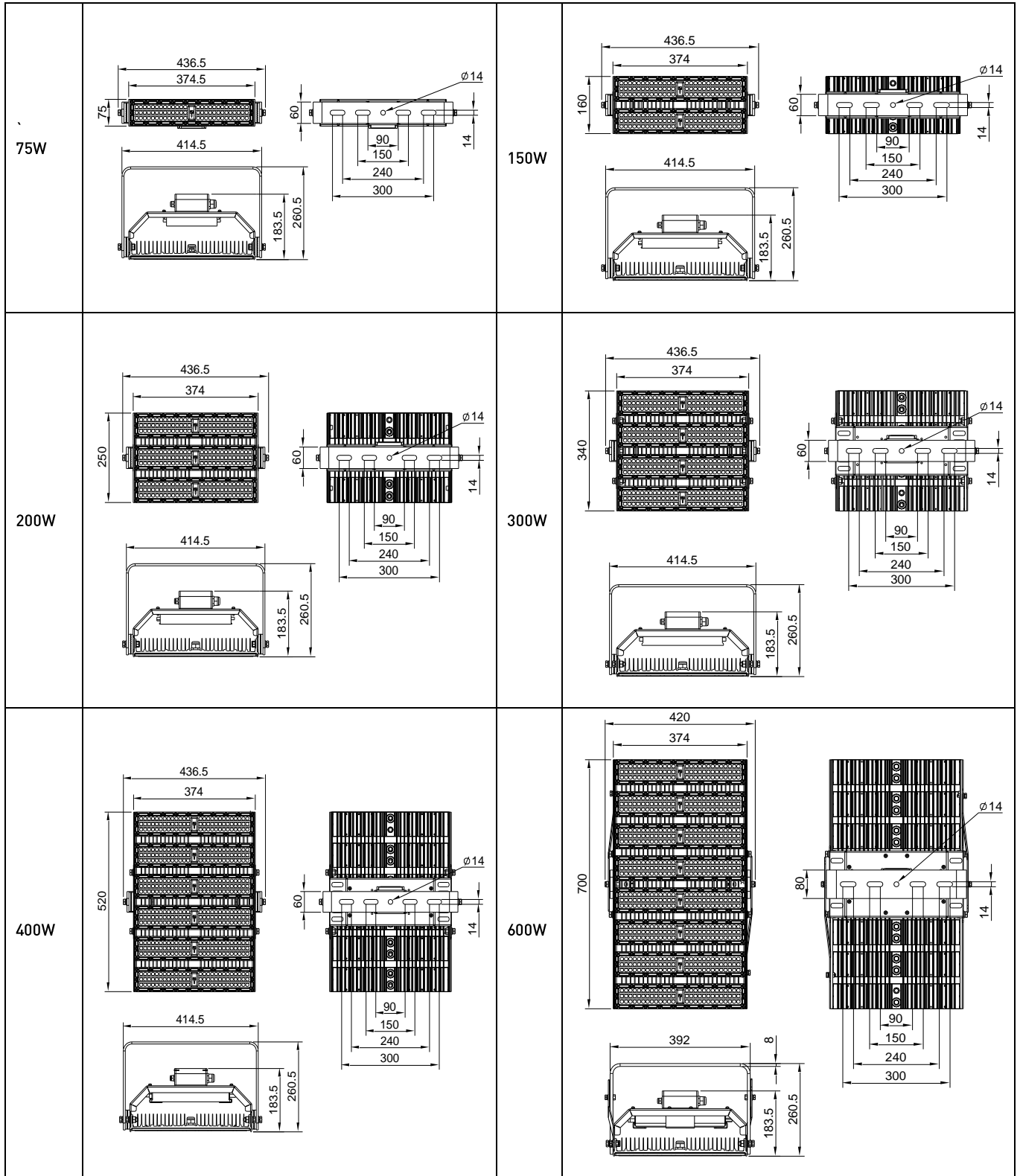

# LF70ES LED Flood Light



## Wiring diagram

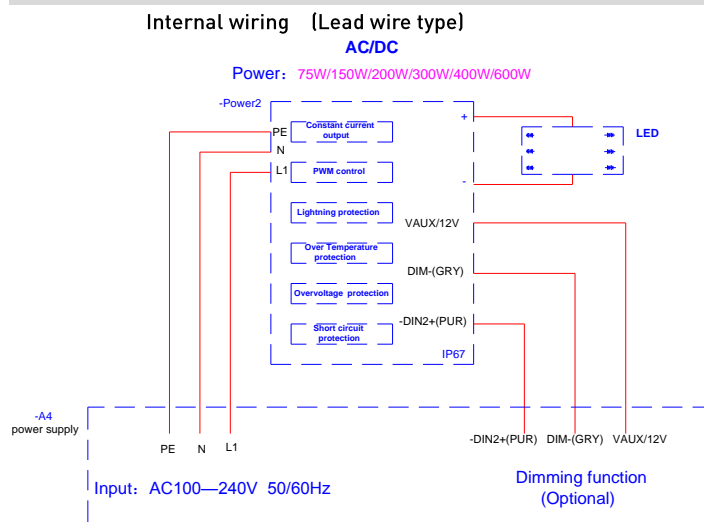

### Caution

- High power LED light has high temperature on product surface while operating, do not cover the product with any objectives. It is suggest the distance more than 3 meters between product and illuminated objective, prevent burns or fire.
- It is normal phenomenon that the lighting surface temperature rising while it is operating.
- Turn off the power when repair or maintain the product, all wiring should be done by a licensed electrician.

### Installation and Operation

- Fix product to mount face by using M12 screws(not provided), ensure mount surface is flat and has enough mechanical strength.
- Secure safety wire to suitable position, ensure the position has enough mechanical strength.
- Connect cable L, N, PE to terminal blocks.
- Ensure cable connection is correct before power on.
- Cable is 16AWG three-core at least.
- No requirement of installation height.

## Lighting distribution curve

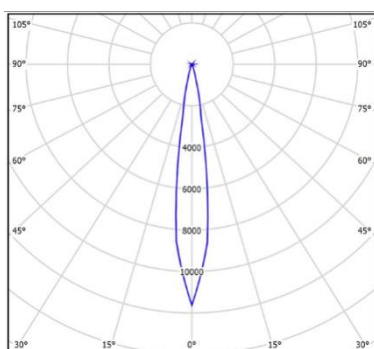

15°

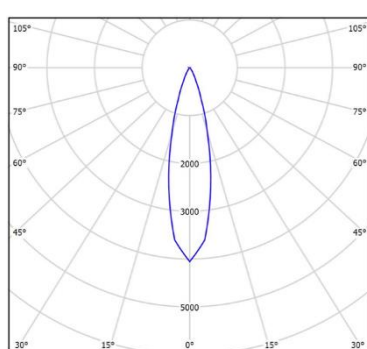

25°

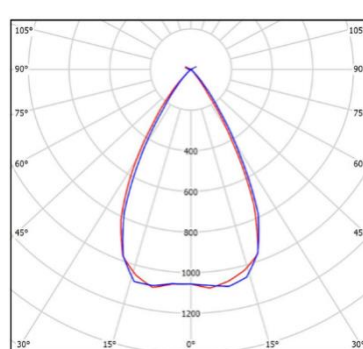

60°

# LF70ES LED Flood Light



## How to Order

Item	Power	Voltage	CCT	Beam angle	Wiring	Mounting	Remark
001	150W	AC100V-AC240V	5500K-6000K	15°	One M20*1.5 metal cable gland	SS Bracket	
002	150W	AC100V-AC240V	5500K-6000K	25°	One M20*1.5 metal cable gland	SS Bracket	
003	150W	AC100V-AC240V	5500K-6000K	60°	One M20*1.5 metal cable gland	SS Bracket	
004	200W	AC100V-AC240V	5500K-6000K	15°	One M20*1.5 metal cable gland	SS Bracket	
005	200W	AC100V-AC240V	5500K-6000K	25°	One M20*1.5 metal cable gland	SS Bracket	
006	200W	AC100V-AC240V	5500K-6000K	60°	One M20*1.5 metal cable gland	SS Bracket	
007	300W	AC100V-AC240V	5500K-6000K	15°	One M20*1.5 metal cable gland	SS Bracket	
008	300W	AC100V-AC240V	5500K-6000K	25°	One M20*1.5 metal cable gland	SS Bracket	
009	300W	AC100V-AC240V	5500K-6000K	60°	One M20*1.5 metal cable gland	SS Bracket	
010	400W	AC100V-AC240V	5500K-6000K	15°	One M20*1.5 metal cable gland	SS Bracket	
011	400W	AC100V-AC240V	5500K-6000K	25°	One M20*1.5 metal cable gland	SS Bracket	
012	400W	AC100V-AC240V	5500K-6000K	60°	One M20*1.5 metal cable gland	SS Bracket	
013	600W	AC100V-AC240V	5500K-6000K	15°	One M20*1.5 metal cable gland	SS Bracket	
014	600W	AC100V-AC240V	5500K-6000K	25°	One M20*1.5 metal cable gland	SS Bracket	
015	600W	AC100V-AC240V	5500K-6000K	60°	One M20*1.5 metal cable gland	SS Bracket	

Thanks for choosing our products, NANHUA Electronics is the professional brand of signal transmission and high quality industrial lighting which is trusted and loved by global users from various industries.

Read and understand these instructions completely and carefully. Wrong installation and operation may lead to fires, electric shock, and others. Due to our continued efforts to improve our products, product specifications are subject to change without notice.

©NANHUA Electronics Co., Ltd. All rights reserved. [www.nanhua.com](http://www.nanhua.com)