



## Main

Range of product	Modicon TM3
Product or component type	Discrete output module
Range compatibility	Modicon M241 Modicon M251 Modicon M221 Modicon M262
Discrete output type	Relay normally open
Discrete output number	16
Discrete output logic	Positive or negative
Discrete output voltage	240 V AC for relay output 30 V DC for relay output
Discrete output current	2000 mA for relay output

## Complementary

Discrete I/O number	16
Current consumption	0 mA at 24 V DC via bus connector (at state off) 75 mA at 24 V DC via bus connector (at state on)
Response time	10 ms (turn-on) 5 ms (turn-off)
Mechanical durability	20000000 cycles
Minimum load	10 mA at 5 V DC for relay output
Local signalling	1 LED per channel (green) for output status
Electrical connection	10 x 1.5 mm <sup>2</sup> removable screw terminal block with pitch 3.81 mm adjustment for outputs
Maximum cable distance between devices	Unshielded cable: <30 m for relay output
Insulation	Between output and internal logic at 2300 V AC Between outputs at 750 V AC Between output groups at 1500 V AC
Marking	CE
Mounting support	Top hat type TH35-15 rail conforming to IEC 60715 Top hat type TH35-7.5 rail conforming to IEC 60715 Plate or panel with fixing kit
Height	90 mm
Depth	84.6 mm
Width	27.4 mm
Product weight	0.145 kg

## Environment

Standards	EN/IEC 61131-2
Product certifications	CULus CE UKCA RCM EAC CULus HazLoc
Resistance to electrostatic discharge	8 kV in air conforming to EN/IEC 61000-4-2 4 kV on contact conforming to EN/IEC 61000-4-2
Resistance to electromagnetic fields	10 V/m 80 MHz...1 GHz conforming to EN/IEC 61000-4-3 3 V/m 1.4 GHz...2 GHz conforming to EN/IEC 61000-4-3 1 V/m 2 GHz...3 GHz conforming to EN/IEC 61000-4-3
Resistance to magnetic fields	30 A/m 50/60 Hz conforming to EN/IEC 61000-4-8

Resistance to fast transients	2 kV for relay output conforming to EN/IEC 61000-4-4
Surge withstand	1 kV I/O common mode conforming to EN/IEC 61000-4-5 DC
Resistance to conducted disturbances	10 V 0.15...80 MHz conforming to EN/IEC 61000-4-6 3 V spot frequency (2, 3, 4, 6.2, 8.2, 12.6, 16.5, 18.8, 22, 25 MHz) conforming to Marine specification (LR, ABS, DNV, GL)
Electromagnetic emission	Radiated emissions - test level: 40 dB $\mu$ V/m QP class A ( 10 m) at 30...230 MHz conforming to EN/IEC 55011 Radiated emissions - test level: 47 dB $\mu$ V/m QP class A ( 10 m) at 230...1000 MHz conforming to EN/IEC 55011
Ambient air temperature for operation	-10...35 °C vertical installation -10...55 °C horizontal installation
Ambient air temperature for storage	-25...70 °C
Relative humidity	10...95 %, without condensation (in operation) 10...95 %, without condensation (in storage)
IP degree of protection	IP20 with protective cover in place
Pollution degree	2
Operating altitude	0...2000 m
Storage altitude	0...3000 m
Vibration resistance	3.5 mm at 5...8.4 Hz on DIN rail 3 gn at 8.4...150 Hz on DIN rail 3.5 mm at 5...8.4 Hz on panel 3 gn at 8.4...150 Hz on panel
Shock resistance	15 gn for 11 ms

## Packing Units

Unit Type of Package 1	PCE
Number of Units in Package 1	1
Package 1 Height	7.426 cm
Package 1 Width	10.516 cm
Package 1 Length	12.583 cm
Package 1 Weight	248.9 g
Unit Type of Package 2	S04
Number of Units in Package 2	42
Package 2 Height	30 cm
Package 2 Width	40 cm
Package 2 Length	60 cm
Package 2 Weight	12.0 kg
Unit Type of Package 3	P12
Number of Units in Package 3	504
Package 3 Height	75 cm
Package 3 Width	120 cm
Package 3 Length	80 cm
Package 3 Weight	136 kg

## Offer Sustainability

Sustainable offer status	Green Premium product
REACH Regulation	<a href="#">REACH Declaration</a>
REACH free of SVHC	Yes
EU RoHS Directive	Pro-active compliance (Product out of EU RoHS legal scope) <a href="#">EU RoHS Declaration</a>
Toxic heavy metal free	Yes
Mercury free	Yes
China RoHS Regulation	<a href="#">China RoHS Declaration</a>
RoHS exemption information	<a href="#">Yes</a>
Environmental Disclosure	<a href="#">Product Environmental Profile</a>
Circularity Profile	<a href="#">End Of Life Information</a>

---

WEEE	The product must be disposed on European Union markets following specific waste collection and never end up in rubbish bins
PVC free	Yes
California proposition 65	WARNING: This product can expose you to chemicals including: Lead and lead compounds, which is known to the State of California to cause cancer and birth defects or other reproductive harm. For more information go to <a href="http://www.P65Warnings.ca.gov">www.P65Warnings.ca.gov</a>

---

Dimensions

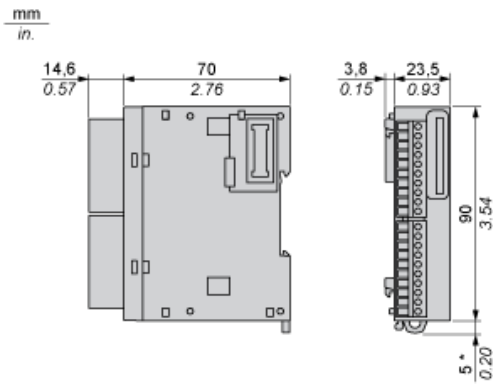

(\*) 8.5 mm/0.33 in. when the clamp is pulled out.

Spacing Requirements

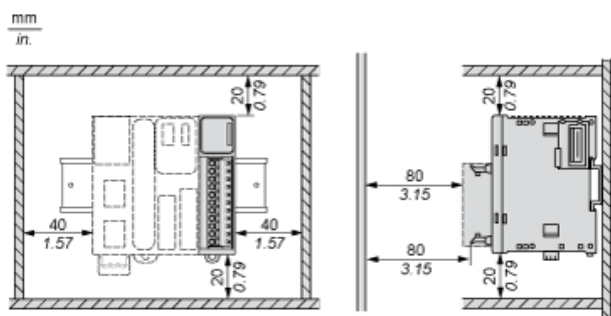

Mounting on a Rail



Incorrect Mounting

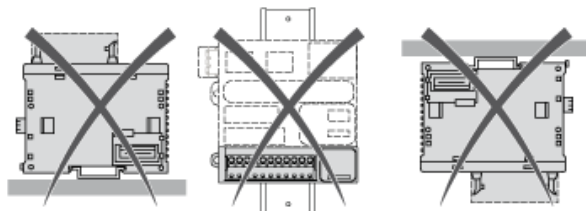

Mounting on a Panel Surface

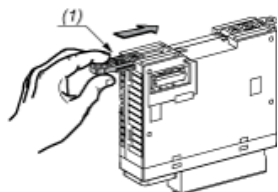

(1) Install a mounting strip

Mounting Hole Layout



Digital Relay Output Module (16-channel)

Wiring Diagram (Positive Logic)

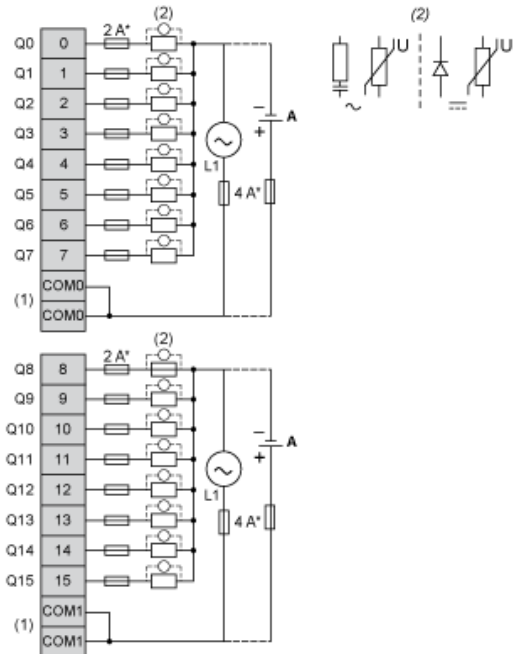

- (\*) Type T fuse
- (1) The COM0 and COM1 terminals are not connected internally.
- (2) To improve the life time of the contacts, and to protect from potential inductive load damage, it is recommended to connect a free wheeling diode in parallel to each inductive DC load or an RC snubber in parallel of each inductive AC load.
- (A) Source wiring (positive logic).

## Wiring Diagram (Negative Logic)

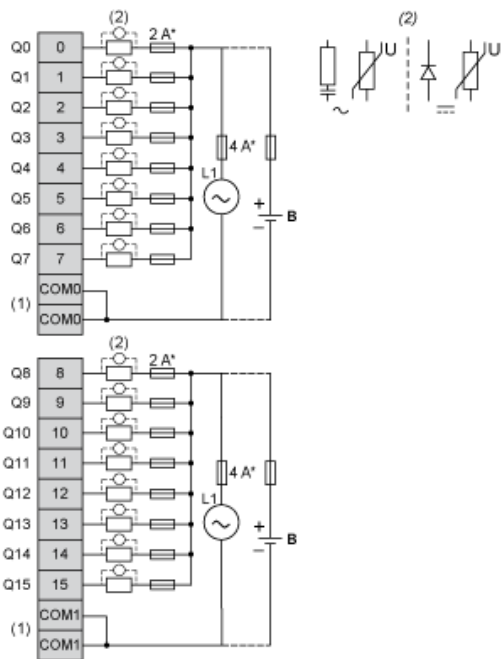

- (\*) Type T fuse
- (1) The COM0 and COM1 terminals are not connected internally.
- (2) To improve the life time of the contacts, and to protect from potential inductive load damage, it is recommended to connect a free wheeling diode in parallel to each inductive DC load or an RC snubber in parallel of each inductive AC load.
- (B) Sink wiring (negative logic)