

## ZB4FW113 (43 059 01)

flush mounted white projecting illuminated pushbutton head for integral LED



### Main

Range of product	Harmony XB4
Product or component type	Head for illuminated push-button
Device short name	ZB4F
Product compatibility	Integral LED ZBZF32 ZBZF33 ZBYF...
Bezel material	Chromium plated metal
Head type	Built-in-flush
Mounting diameter	30.5 mm
Sale per indivisible quantity	1
Shape of signaling unit head	Round
Type of operator	Spring return
Operator profile	White projecting unmarked
Operator additional information	With plain lens

### Complementary

CAD overall width	36.6 mm
CAD overall height	36.6 mm
CAD overall depth	35 mm
Product weight	0.06 kg
Resistance to high pressure washer	7000000 Pa at 55 °C, distance: 0.1 m
Mechanical durability	10000000 cycles
Electrical composition code	M1 for 6 contacts using single blocks in front mounting with integral LED M2 for 6 contacts using single and double blocks in front mounting with integral LED M6 for 2 contacts using single blocks in front mounting with integral LED and transformer M10 for 2 contacts using single blocks in front mounting with integral LED

### Environment

protective treatment	TH
ambient air temperature for storage	-40...70 °C
ambient air temperature for operation	-40...70 °C
overvoltage category	Class I conforming to IEC 60536
IP degree of protection	IP66 conforming to IEC 60529 IP69K IP69
NEMA degree of protection	NEMA 13 NEMA 4X
IK degree of protection	IK05 conforming to EN 50102
standards	EN/IEC 60947-1 EN/IEC 60947-5-1 EN/IEC 60947-5-4 JIS C 4520 UL 508 CSA C22.2 No 14
product certifications	CSA UL listed
vibration resistance	5 gn (f = 2...500 Hz) conforming to IEC 60068-2-6
shock resistance	30 gn (duration = 18 ms) for half sine wave acceleration conforming to IEC 60068-2-

The information provided in this documentation contains general descriptions and/or technical characteristics of the products contained herein. This documentation is not intended as a substitute for and is not to be used for determining suitability or reliability of these products for specific user applications. It is the duty of any such user or integrator to perform the appropriate and complete risk analysis, evaluation and testing of the products with respect to the relevant specific application or use thereof. Neither Schneider Electric Industries SAS nor any of its affiliates or subsidiaries shall be responsible or liable for misuse of the information contained herein.

## Offer Sustainability

Sustainable offer status	Green Premium product
RoHS (date code: YYWW)	Compliant - since 0627 - Schneider Electric declaration of conformity
REACH	Reference not containing SVHC above the threshold
Product environmental profile	Available
Product end of life instructions	Need no specific recycling operations

## Dimensions

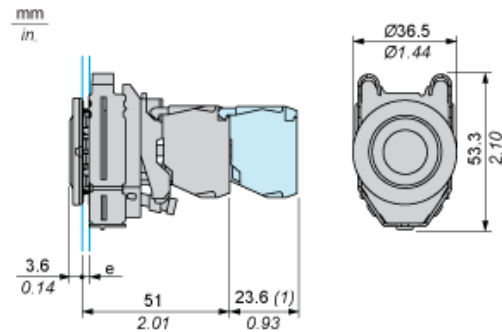

e : clamping thickness: 1 to 6 mm / 0.04 to 0.24 in.  
 (1) : Additional row of contacts

## Panel Cut-out for Pushbuttons, Switches and Pilot Lights (Finished Holes, Ready for Installation)

### Connection by Screw Clamp Terminals or Plug-in Connectors

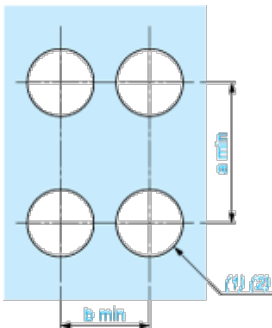

(1) : Diameter on finished panel or support  
 (2) : Ø30.75 mm recommended (Ø30.5<sub>0</sub><sup>+0.5</sup>) / Ø1.21 in. recommended (Ø1.20 in. <sub>0</sub><sup>+0.0196</sup>)

Connections	a in mm	a in in.	b in mm	b in in.
By connectors	50	1.97	40	1.57
By connectors and with legend holder ZBZF32	50	1.97	40	1.57
By connectors and with legend holder ZBZF33	60	2.36	40	1.57

## Electrical Composition Corresponding to Codes M1 and M7

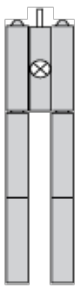

**Electrical Composition Corresponding to Codes M2 and M8**

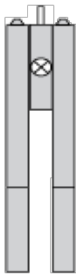

**Electrical Composition Corresponding to Codes M6 and P2**



**Electrical Composition Corresponding to Codes M5, M10, MF1, MR1 and MF2**



**Legend**

Single contact



Double contact



Light block



Possible location

