

Click [here](#) for production status of specific part numbers.

MAX31343 SHIELD

Evaluates: MAX31343

General Description

The MAX31343 SHIELD is a fully assembled and tested PCB to evaluate the MAX31343, low-cost, extremely accurate, real-time clock (RTC) with I²C interface and power management. The shield operates from a single supply, either from USB or external power supply, and the integrated microelectromechanical systems (MEMS) resonator enhances the long-term accuracy and eliminates the external crystal requirement in the system. This device is accessed through an I²C serial interface provided by a MAX32625 PICO board.

The MAX31343 shield provides the hardware and software user interface (GUI) necessary to evaluate the MAX31343. The kit includes a MAX31343EKA+T. It connects to the PC through a MAX32625 PICO board and a micro-USB cable.

Features

- Easy Evaluation of the MAX31343
- +1.6V to +5.5V Single-Supply Operation
- Proven PCB Layout
- Fully Assembled and Tested

Shield Photo

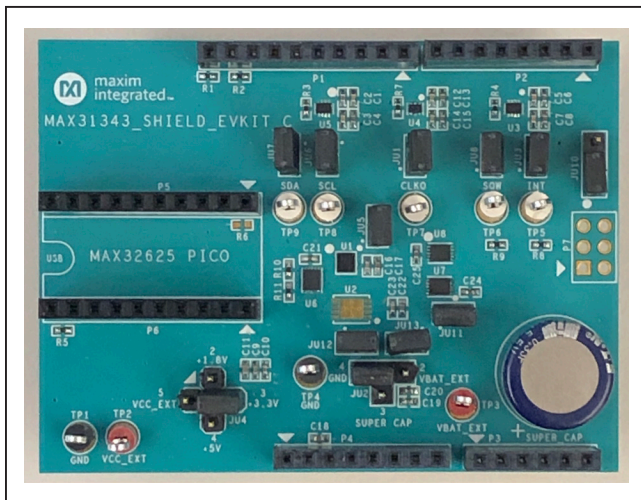

Shield Contents

- Assembled MAX32625 PICO controller board
- Micro-USB cable
- Assembled circuit board including MAX31343EKA+T

Quick Start

Required Equipment

- One pico ammeter for measuring the current
- One oscilloscope and one oscilloscope probe
- One PC or laptop with Microsoft Windows® 7 or later
- One USB A male to micro B male cable
- One assembled and programmed MAX32625 PICO board
- One MAX31343 shield

Ordering Information appears at end of data sheet.

PICO Board Photo

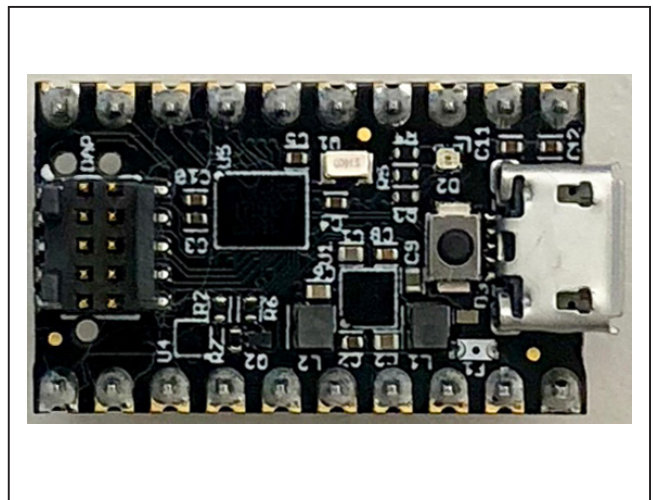

Windows is a registered trademark and registered service mark of Microsoft Corporation.

Procedure

The shield is fully assembled and tested. Use the following steps to verify board operation.

- 1) Place the MAX31343 shield on a nonconductive surface to ensure that nothing on the PCB gets shorted to the workspace.
- 2) Verify that all jumpers are in their default position as shown on [Table 1](#).
- 3) Connect the MAX32625 PICO board to the shield at the location shown as MAX32625 PICO ([Figure 1](#)).
- 4) Connect the USB A male to micro B male cable between the MAX32625 PICO board and PC/Laptop.
- 5) Go to the MAX31343 shield product page to download and install the latest version of MAX31343 RTC SHIELD software.
- 6) Open the MAX31343 RTC SHIELD software, shown as [Figure 2](#).

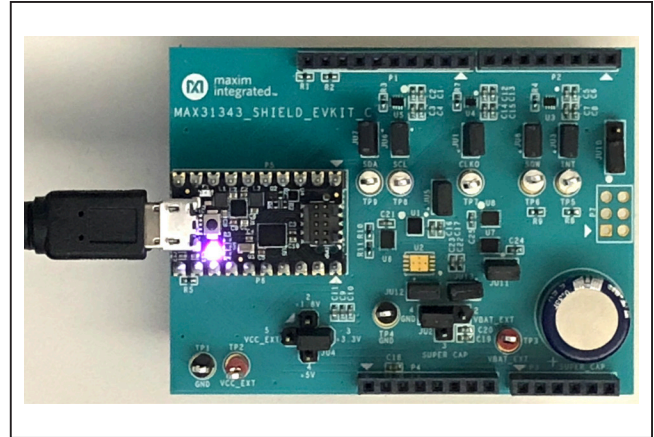

Figure 1. Connection and Setup

Table 1. Jumper Settings

JUMPER	SHUNT POSITION	DESCRIPTION
JU1	1-2*	Connects clock output to pin 6 of P2 Arduino®/Mbed® connector
	Open	Disconnects clock output from Arduino/Mbed connector
JU2	1-2	Connects backup supply to external DC supply
	1-3	Connects backup supply to super capacitor
	1-4*	Connects backup supply to ground
	Open	Disconnects backup supply
JU3	1-2*	Connects interrupt signal to pin 3 of P2 Arduino/Mbed connector
	Open	Disconnects interrupt signal from Arduino/Mbed connector
JU4	1-2	Connects VCC supply to +1.8V on board supply
	1-3*	Connects VCC supply to +3.3V on board supply
	1-4	Connects VCC supply to +5.0V on board supply
	1-5	Connects VCC supply to external DC supply
	Open	Disconnects VCC
JU5	1-2*	Connects VCC to MAX31343 IC WLP package (U1)
	Open	Disconnects VCC from MAX31343 IC WLP package (U1)
JU8	1-2*	Connects square wave output to pin 4 of P2 Arduino/Mbed connector
	Open	Disconnects square wave output from Arduino/Mbed connector
JU10	1-2*	Sets MAX31343 WLP package (U1) IC under test
	2-3	Sets MAX31343 TDFN package (U2) IC under test
JU11	1-2*	Connects VCC to MAX31343 IC TDFN package (U2)
	Open	Disconnects VCC from MX31343 IC TDFN package (U2)
JU12	1-2*	Connects VBAT to MAX31343 IC WLP package (U1)
	Open	Disconnects VBAT from MAX31343 IC WLP package (U1)
JU13	1-2*	Connects VBAT to MAX31343 IC TDFN package (U2)
	Open	Disconnects VBAT from MAX31343 IC TDFN package (U2)

*Default position

Arduino is a registered trademark of Arduino, LLC.

Mbed is a trademark Arm Limited (or its subsidiaries) in the US and/or elsewhere.

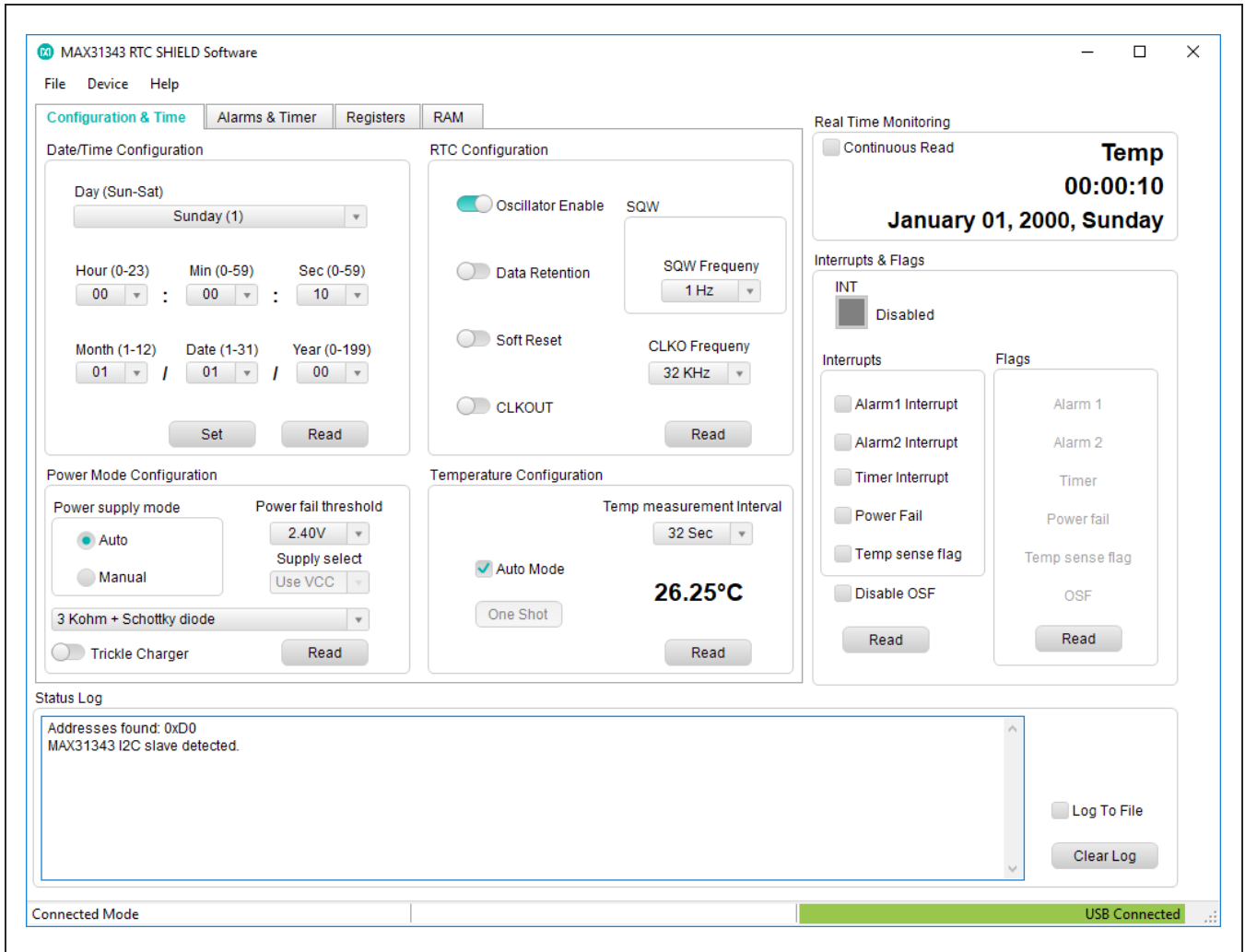

Figure 2. MAX31343 RTC SHIELD Software—Configuration & Time Page

Detailed Description

The MAX31343 shield is a low-cost, extremely accurate real-time clock (RTC). It is driven by an internal temperature-compensated microelectromechanical systems (MEMS) resonator. The oscillator provides a stable and accurate reference clock and maintains the RTC to within ± 0.432 seconds-per-day accuracy from -40°C to $+85^{\circ}\text{C}$. The RTC device is accessed through an I²C serial interface.

The RTC maintains seconds, minutes, hours, day, date, month, year, and century information. The date at the end of the month is automatically adjusted for months with fewer than 31 days, including corrections for leap year up to the year 2199. The clock operates in the 24-hour format. Other features including two programmable time-of-day alarms, interrupt output, uncompensated programmable clock output, and temperature compensated programmable square-wave output. A voltage reference and comparator circuit monitor the status of VCC to detect power failures and automatically switch to the backup supply when necessary.

Detailed Description of Software and Functional Test Procedure

Real Time Monitoring

To monitor the time and date, on **Configuration & Time** page, under the **RTC Configuration** group box, enable **Oscillator Enable toggle** button, and under **Real Time Monitoring** group box, check **Continuous Read** checkbox for continuous reading.

Current Draw at Time-Keeping Mode

To measure the current draw under normal real-time clock conditions, without any interrupt or CLKO output:

- 1) Remove the jumper from JU5.
- 2) With the output set to +3.3V and disabled, connect the negative terminal of the pico ammeter to the pin 1 of the JU5 (marked as a white dot) and the positive terminal to pin 2 of JU5.
- 3) On the **Configuration & Time** tab, in the **Date/Time Configuration** group box, press the **Read** button. In the **RTC Configuration** group box, disable the **CLKOUT** toggle button, and select **1Hz** in **SQW Frequency** drop-down list. In the **Real Time Monitoring** group box, uncheck the **Continuous Read** check box.
- 4) The reading in the pico ammeter is the current consumed by MAX31343 IC only. It should be around 940nA.

CLKOUT Frequency

On the **Configuration & Time** tab of the software, under the **RTC Configuration** group box, enable the **CLKOUT** toggle button and select the desired frequency. The clock output can be monitored using an oscilloscope connected to CLKO test point (TP7). A frequency counter can also be used to measure the clock frequency accurately.

Alarm and Timer Configuration

Use the **Alarm & Timer Configuration** tab to configure Alarm 1, Alarm 2, and timer. ([Figure 3](#))

For more details on using the software, refer to the *MAX31343 Shield Software User Guide*.

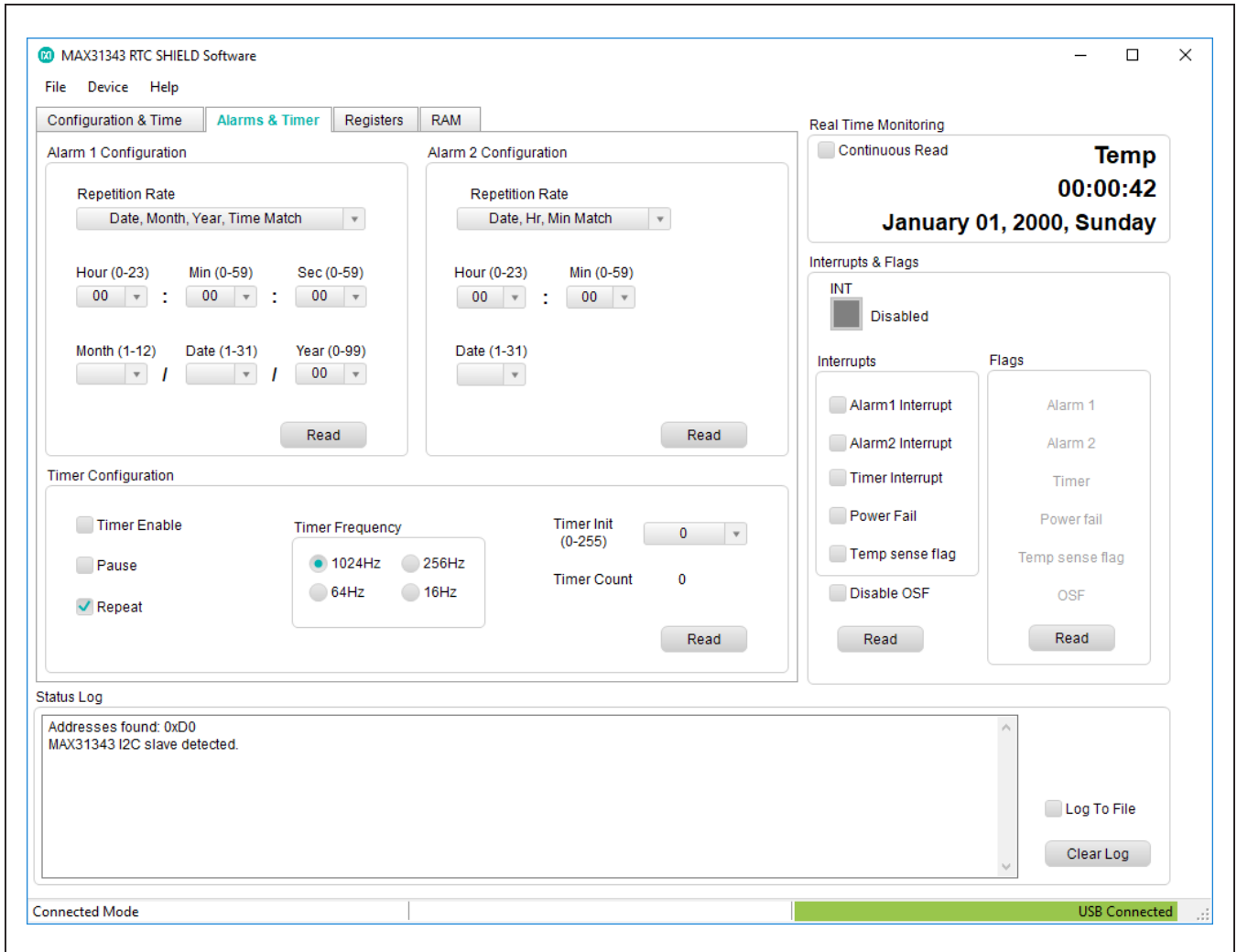

Figure 3. MAX31343 RTC SHIELD Software—Alarms & Timer Page

Registers Tab

Write and read the MAX31343 IC register map in the Register tab. (Figure 4)

For more details on using the software, refer to the *MAX31343 Shield Software User Guide*.

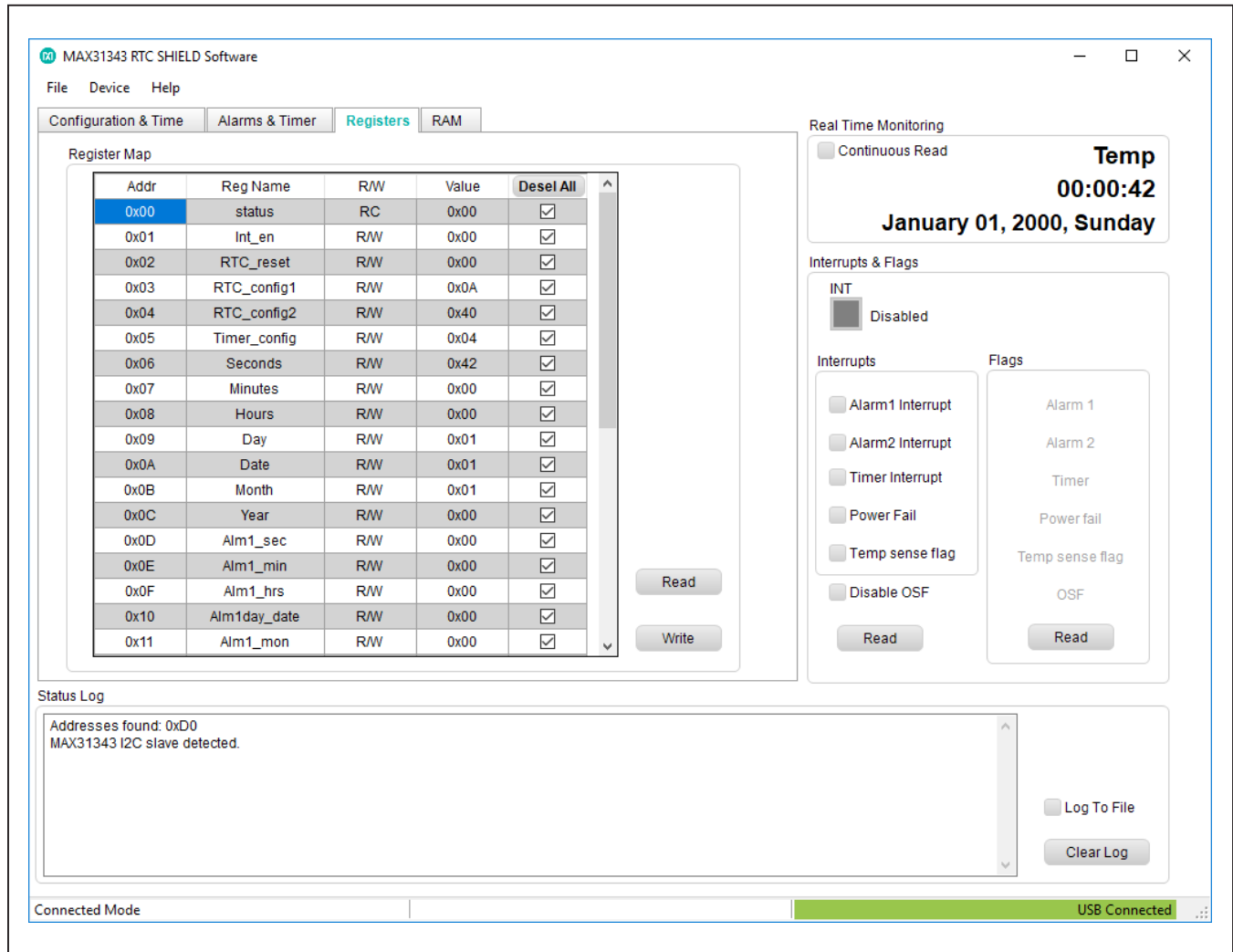

Figure 4. MAX31343 RTC SHIELD Software—Registers Page

Ordering Information

PART	TYPE
MAX31343SHLD#	Shield

#Denotes RoHS compliance.

MAX31343 SHIELD Bill of Materials

ITEM	REF DES	DNI/DNP	QTY	MFG PART #	MANUFACTURER	VALUE	DESCRIPTION
1	C1, C3, C5, C7, C12, C14, C16, C23	-	8	C0402C103J3RAC	KEMET	0.01UF	CAPACITOR; SMT (0402); CERAMIC CHIP; 0.01UF; 25V; TOL=5%; TG=-55 DEGC TO +125 DEGC; TC=X7R
2	C2, C4, C6, C8, C10, C13, C15, C17, C20-C22, C24, C25	-	13	C1005X7R1C104K050BC;ATC530L104KT16; 0402YC104KAT2A;CGA2B1X7R1C104K050BC; GCM155R71C104KA55;C0402X7R160-104KNE; CL05B104K05NUNC;GRM155R71C104KA88; C1005X7R1C104K;CC0402KRX7R7B104; EMK105B7104KV;CL05B104K05	TDK;AMERICAN TECHNICAL CERAMICS; AVK;TDK;MURATA;VENKEL LTD.; SAMSUNG ELECTRONICS;MURATA; TDK;YAGEO PHICOMP;TAIYO YUDEN; SAMSUNG ELECTRONICS	0.1UF	CAPACITOR; SMT (0402); CERAMIC CHIP; 0.1UF; 16V; TOL=10%; TG=-55 DEGC TO +125 DEGC; TC=X7R
3	C9, C19	-	2	CL05B105KQ5NQNC; GRM155R70J105KA12	SAMSUNG ELECTRONICS;MURATA	1UF	CAPACITOR; SMT (0402); CERAMIC CHIP; 1UF; 6.3V; TOL=10%; TG=-55 DEGC TO +125 DEGC; TC=X7R
4	C11, C18	-	2	GRM155R61A106ME44;GRM155R61A106ME11; 0402ZD106MAT2A;CL05A106MP5NUNC	MURATA;MURATA;AVX;SAMSUNG	10UF	CAPACITOR; SMT (0402); CERAMIC CHIP; 10UF; 10V; TOL=20%; TG=-55 DEGC TO +85 DEGC; TC=X5R
5	JU1, JU3, JU5-JU8, JU11-JU13	-	9	PCC02SAAN	SULLINS	PCC02SAAN	CONNECTOR; MALE; THROUGH HOLE; BREAKAWAY; STRAIGHT THROUGH; 2PINS; -65 DEGC TO +125 DEGC
6	JU2	-	1	PEC04SAAN	SULLINS ELECTRONICS CORP.	PEC04SAAN	CONNECTOR; MALE; THROUGH HOLE; BREAKAWAY; STRAIGHT; 4PINS
7	JU4	-	1	TSW-105-07-L-S	SAMTEC	TSW-105-07-L-S	EVKIT PART-CONNECTOR; THROUGH HOLE; TSW SERIES; SINGLE ROW; STRAIGHT; 5PINS
8	JU10	-	1	PBC03SAAN	SULLINS	PBC03SAAN	CONNECTOR; MALE; THROUGH HOLE; BREAKAWAY; STRAIGHT; 3PINS; -65 DEGC TO +125 DEGC
9	P1	-	1	SSQ-110-04-G-S	SAMTEC	SSQ-110-04-G-S	CONNECTOR; FEMALE; THROUGH HOLE; .025IN SQ POST SOCKET; STRAIGHT; 10PINS ;
10	P2, P4	-	2	SSQ-108-04-G-S	SAMTEC	SSQ-108-04-G-S	CONNECTOR; FEMALE; THROUGH HOLE; .025IN SQ POST SOCKET; STRAIGHT; 8PINS ;
11	P3	-	1	SSQ-106-04-G-S	SAMTEC	SSQ-106-04-G-S	CONNECTOR; FEMALE; THROUGH HOLE; .025IN SQ POST SOCKET; STRAIGHT; 6PINS ;
12	P5, P6	-	2	PPPC101LFBN-RC	SULLINS ELECTRONICS CORP.	PPPC101LFBN-RC	CONNECTOR; FEMALE; THROUGH HOLE; HEADER CONNECTOR; STRAIGHT; 10PINS
13	R1-R4, R7-R11	-	9	ERJ-2GEJ103	PANASONIC	10K	RESISTOR; 0402; 10K OHM; 5%; 200PPM; 0.10W; THICK FILM
14	R5	-	1	ERJ-2GEOR00	PANASONIC	0	RESISTOR; 0402; 0 OHM; 0%; JUMPER; 0.10W; THICK FILM
15	SUPER_CAP	-	1	KW-SR5C334-R	EATON POWERING BUSINESS WORLDWIDE	0.33F	CAP; THROUGH HOLE-RADIAL LEAD; 0.33F; +80%/-20%; 5.5V; ALUMINUM-ELECTROLYTIC ;
16	TP1, TP4	-	2	5011	KEYSTONE	N/A	TEST POINT; PIN DIA=0.125IN; TOTAL LENGTH=0.445IN; BOARD HOLE=0.063IN; BLACK; PHOSPHOR BRONZE WIRE SILVER PLATE FINISH;
17	TP2, TP3	-	2	5010	KEYSTONE	N/A	TEST POINT; PIN DIA=0.125IN; TOTAL LENGTH=0.445IN; BOARD HOLE=0.063IN; RED; PHOSPHOR BRONZE WIRE SIL;
18	TP5-TP9	-	5	5012	KEYSTONE	N/A	TEST POINT; PIN DIA=0.125IN; TOTAL LENGTH=0.445IN; BOARD HOLE=0.063IN; WHITE; PHOSPHOR BRONZE WIRE SILVER PLATE FINISH;
19	U1	-	1	MAX31343EKA+	MAXIM	MAX31343EKA+	EVKIT PART-IC; MAX31343EKA+; +/-4PPM; I2C REAL-TIME CLOCK WITH INTEGRATED MEMS OSCILLATOR; PACKAGE OUTLINE: 21-100336; PACKAGE CODE: K82A2+1
20	U2	DNI	1	MAX31343ETAY+	MAXIM	MAX31343ETAY+	EVKIT PART-IC; MAX31343ETAY+; +/-4PPM; I2C REAL-TIME CLOCK WITH INTEGRATED MEMS OSCILLATOR; PACKAGE OUTLINE: 21-100322; PACKAGE LAND PATTERN: 90-100121; PACKAGE CODE: T834MKY+1
21	U3, U5	-	2	NLSX4373MUTAG	ON SEMICONDUCTOR	NLSX4373MUTAG	IC; TRANS; 2-BIT 20 MB/S DUAL-SUPPLY LEVEL TRANSLATOR; UDFN8
22	U4	-	1	NLSX4401MU1TCG	ON SEMICONDUCTOR	NLSX4401MU1TCG	IC; TRANS; 1-BIT 20 MB/S DUAL-SUPPLY LEVEL TRANSLATOR; UDFN6
23	U6-U8	-	3	MAX14689AETB+	MAXIM	MAX14689AETB+	IC; ASW; ULTRA-SMALL LOW-RON BEYOND-THE-RAILS DPDT ANALOG SWITCHES; TDFN10-EP
24	PCB	-	1	MAX31343SHIELD	MAXIM	PCB	PCB:MAX31343SHIELD
25	P7	DNP	0	SSQ-103-03-G-D	SAMTEC	SSQ-103-03-G-D	CONNECTOR; FEMALE; THROUGH HOLE; SSQ SERIES ; STRAIGHT; 6PINS
26	R6	DNP	0	N/A	N/A	OPEN	PACKAGE OUTLINE 0402 RESISTOR
TOTAL			72				

MAX31343 SHIELD Schematics

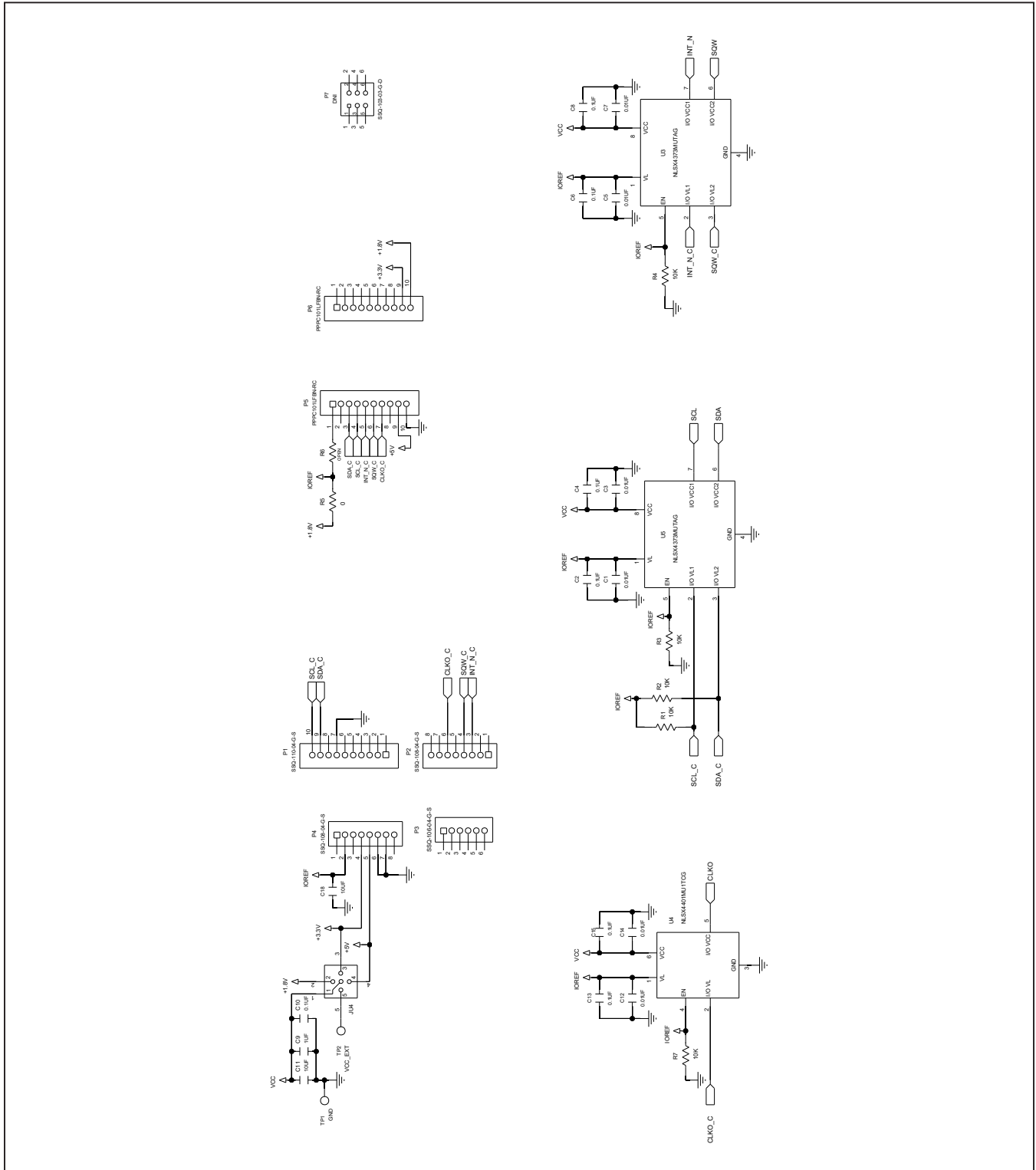

MAX31343 SHIELD Schematics (continued)

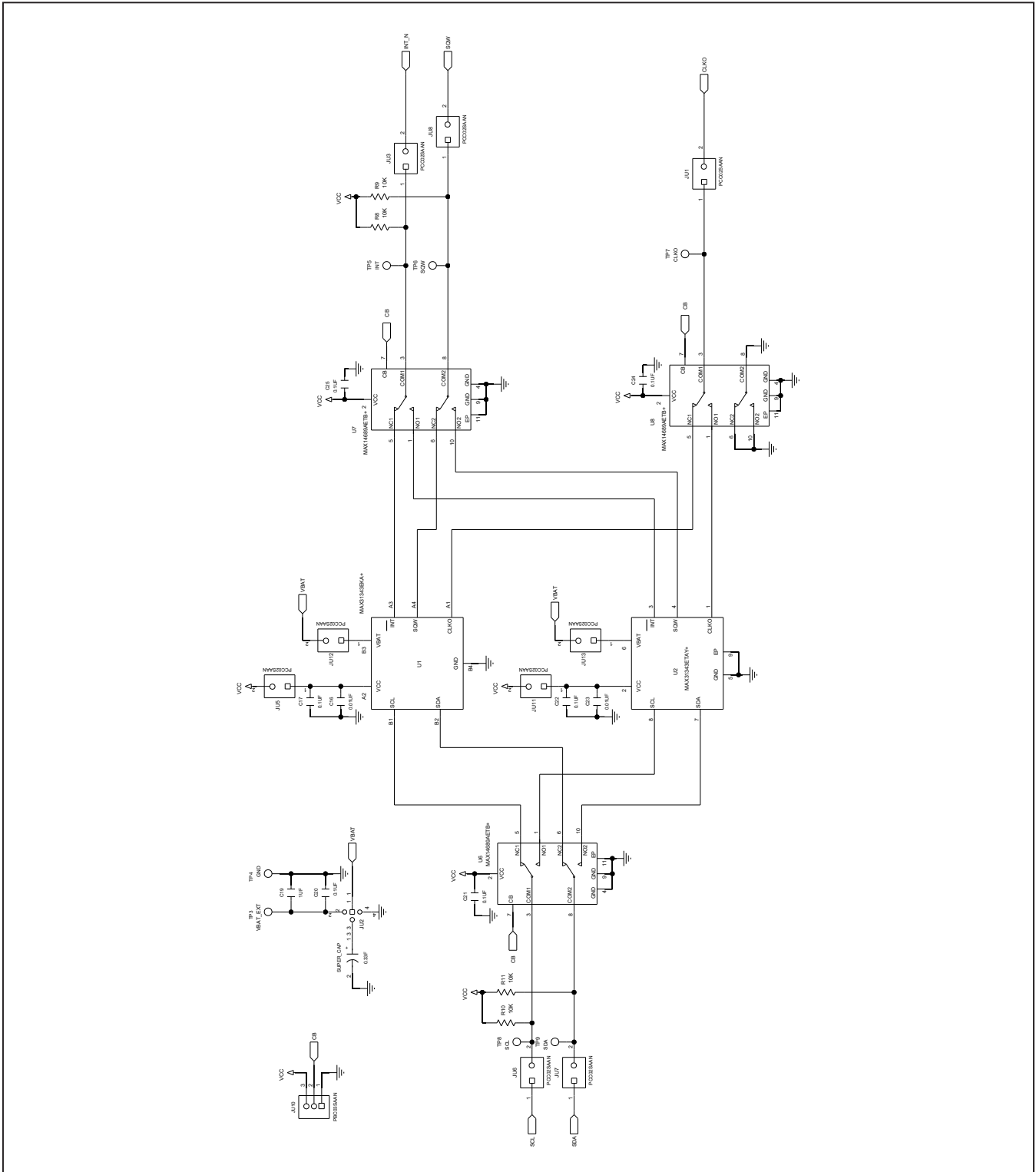

MAX31343 SHIELD PCB Layouts

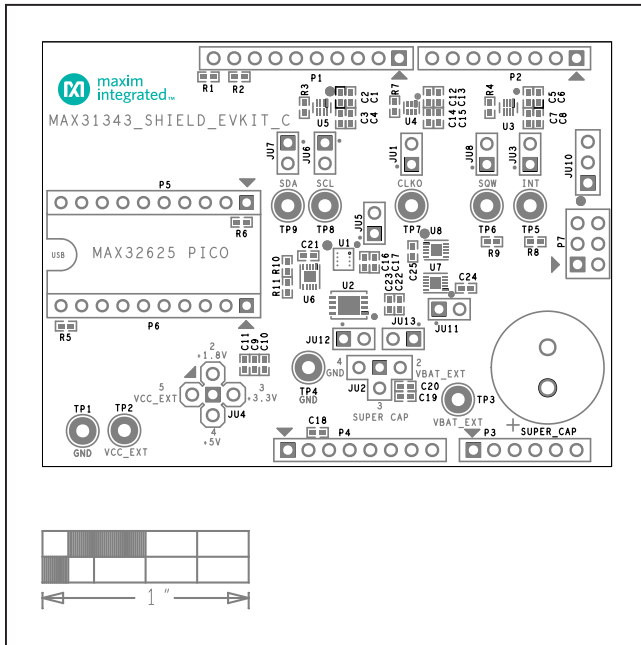

MAX31343 SHIELD Component Placement Guide—Top Silkscreen

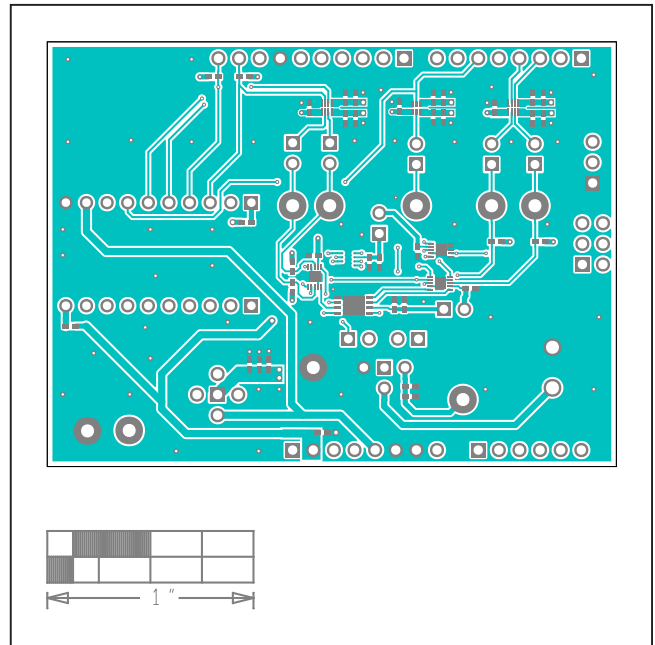

MAX31343 SHIELD PCB Layout—Top

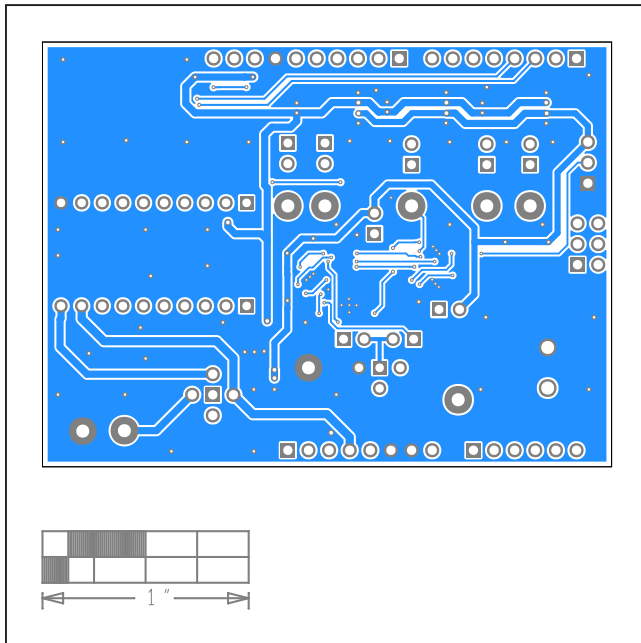

MAX31343 SHIELD PCB Layout—Bottom

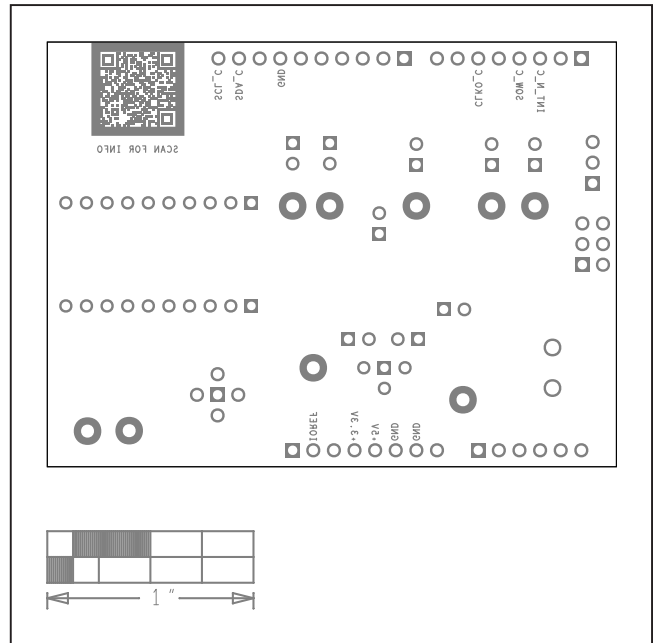

MAX31343 SHIELD Component Placement Guide—Bottom Silkscreen

Revision History

REVISION NUMBER	REVISION DATE	DESCRIPTION	PAGES CHANGED
0	4/20	Initial release	—

For pricing, delivery, and ordering information, please visit Maxim Integrated's online storefront at <https://www.maximintegrated.com/en/storefront/storefront.html>.

Maxim Integrated cannot assume responsibility for use of any circuitry other than circuitry entirely embodied in a Maxim Integrated product. No circuit patent licenses are implied. Maxim Integrated reserves the right to change the circuitry and specifications without notice at any time.