

P/N 0E3C1/16111EAA

Diaphragm pump in aluminum series AAB-12 with membranes in EPDM, balls and seats in acetal

SECTORS OF USE

Agriculture, Automotive, Building and road construction, Lube trucks and transports

FEATURES

Ratio	1:1
Flow rate	70 l/min
Max pressure	8 bar
Max cycles per minute	400 cpm
Delivery per cycles	0,188 l
Max suction lift	dry column 4,5 m - wet column 7,5 m
Max size pumpable solids	1,5 mm
Max working temperature	100 °C
Noise level	75 dB
Max air consumption	0,80 m ³ /min
Air working pressure	2÷6 bar
Air inlet connection	G 3/8" (f)
Air outlet connection (muffler)	G 1/2" (f)
Fluid inlet connection	G 3/4" (f)
Fluid outlet connection	G 1/2" (f)
Balls for inlet	ball valve
Membranes	EPDM
Balls	acetal



OVERALL DIMENSIONS (mm)

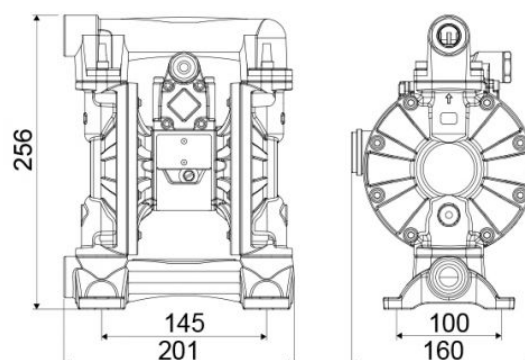

Seats	acetal
Packing	No. 1 - 0,020 m ³
Gross weight	6,3 kg