

ESTABLISHED & SONS
United Kingdom
Phone +44 (0)20 7608 0990
establishedandsons.com

ESTANDSONS LTD
Estandsons Warehouse
Intereuropa d.d.
Mednarodni prehod 8,
SI-5290 Šempeter pri Gorici,
Slovenija

ZERO-IN BARBER OSGERBY

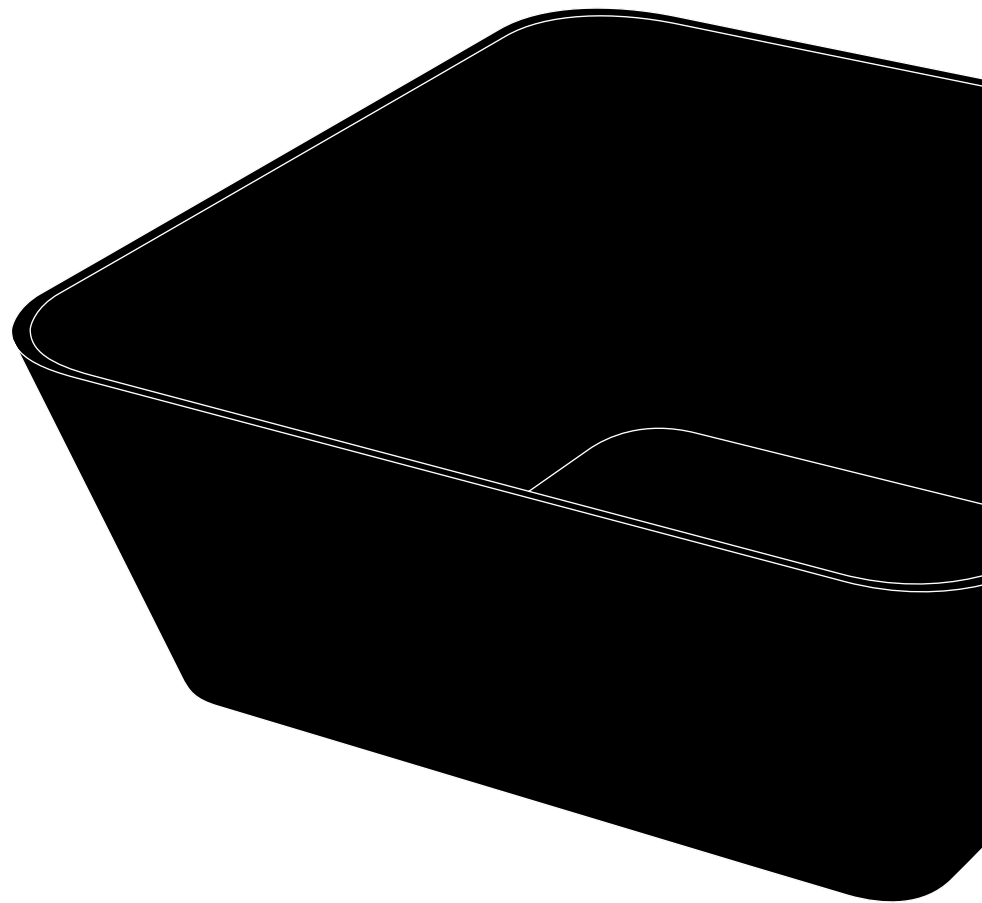

ZERO-IN

BARBER OSGERBY

The Zero-In table creates an illusion of weightlessness, with seamless sloping walls at unexpected angles topped with a glass surface, all supported by hidden feet that create a shadow gap below the structure.

THE DESIGNER

Edward Barber and Jay Osgerby founded their London studio in 1996 after graduating with Master's in Architecture from the prestigious Royal College of Art in London. Their diverse body of work spans industrial design, furniture, lighting and site-specific installations, as well as gallery and public commissions such as the London 2012 Olympic Torch and projects for the Royal Mint. Barber Osgerby's work is held in permanent museum collections around the world including London's V&A Museum and Design Museum, the Metropolitan Museum of Art in New York and the Art Institute of Chicago.



General Information

IMPORTANT, RETAIN FOR FUTURE REFERENCE: READ CAREFULLY

DESIGN
2005

DESCRIPTION
Low Table

MATERIALS
Satin-finish polyester moulded compound, 4mm toughened glass

DIMENSIONS
L900mm × D900mm × H350mm

USER INSTRUCTIONS

Established & Sons disclaims any responsibility deriving from incorrect use of the mentioned object. Do not place very hot or very cold items on the glass surface unless adequately thick table mats are used to prevent such items from coming into contact with the glass. Do not sit or stand upon the glass surface. Do not use the glass as a chopping surface or strike the glass with hard or pointed items. Avoid contact with heat sources. For major maintenance or repairs, consult the retailer. Once the product or its components are no longer used, make sure that they are disposed of correctly through the public waste disposal services.

CLEANING GUIDELINES

Base

Clean the base using a soft non-abrasive cloth. An ideal cleaning product to use is deionised water (Tap water contains salts that can leave a residue on the surface of the polyester) with a mild, non-coloured detergent, such as, Ecover Washing Up liquid. To avoid temporary streaking and residue, dry using a soft cloth.

It is advisable to dust the base with a lint free cloth before applying any cleaning fluid. This will remove any grit that could cause scratches to the surface.

Glass

It is advisable to dust the glass before applying any cleaning fluid. This will remove any grit that could cause scratches to the surface. We recommend using a mild glass cleaner, such as Ecover and paper/kitchen towel. Always apply the cleaning fluid to the paper towel first and not directly onto the glass. Do not use washing powders or any other substances containing abrasives as these will scratch the glass.

IMPORTANT NOTICE

Please keep these instructions for future reference. Internal Packaging should also be retained to allow for the removal of glass for cleaning. Glass tested to BS EN12150
WARNING If the glass is chipped or broken, stop using the product and consult the manufacturer or supplier. Avoid contact with certain solvents, including white spirit, toluene based products and acetone. Beware of many household cleaning products and polishes as these may contain potentially damaging solvents.

Installation

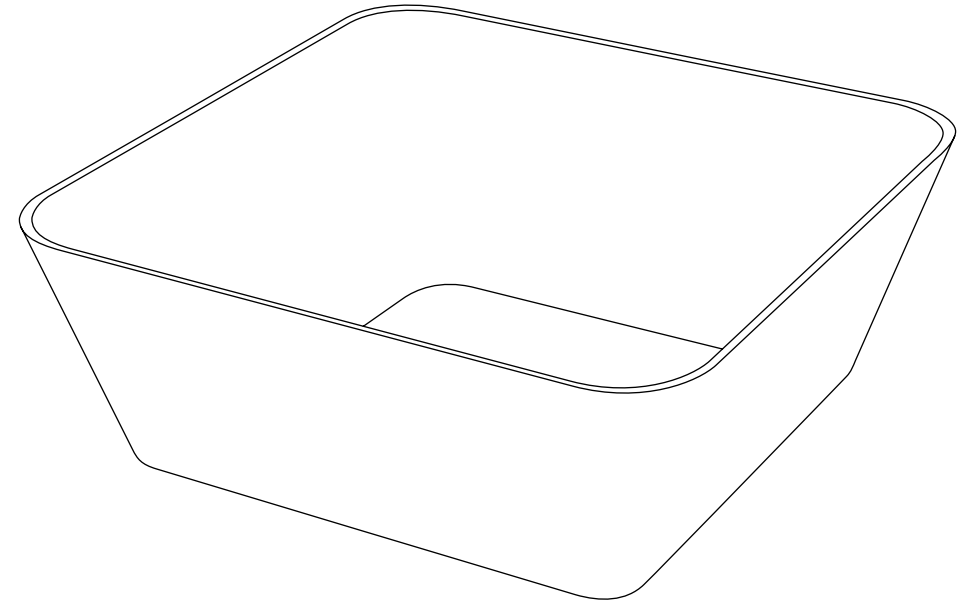

-
1. Assemble the internal packaging by slotting them together into a cross shape and place on the floor near the Zero-In.

Carefully lift the Zero-In up and over the cross and place it back on the floor so that the internal packaging is inside the Zero-In and raising the glass.

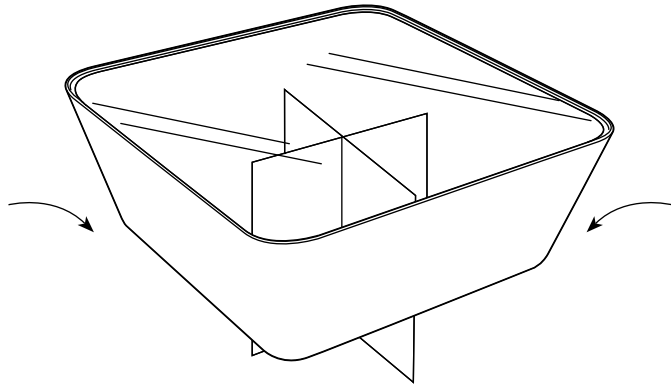

-
2. Carefully remove the glass and clean according to the cleaning guidelines listed in these instructions (A), Place the glass on top of the cardboard support in the middle of the Zero-In and align it with the base (B).
-

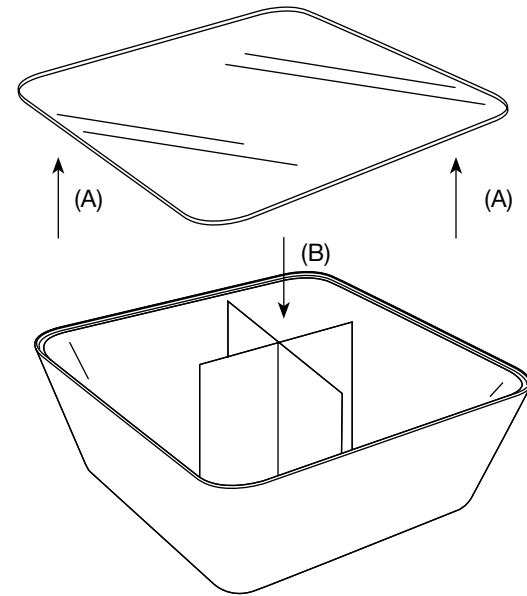

-
3. Carefully lift the Zero-In so that the glass sits back in place on the inside edge (Adjust as needed), and over the cardboard support.
-

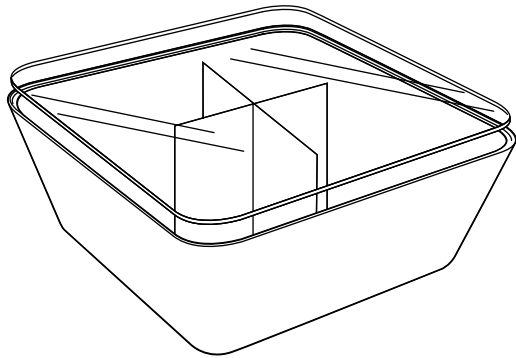

-
4. Place the Zero-In back on the floor in position.
-

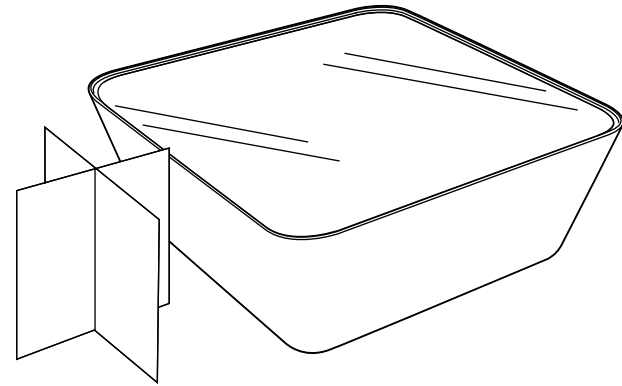

About Established & Sons

Established & Sons is a British brand representing all that is innovative in contemporary design. By supporting the best creators of our time, it has built a collection for people who are passionate about design, presenting imaginative products with style and personality.

Designers and artists are afforded the freedom to explore their own language, advancing pioneering ideas that deliver exceptional furniture and lighting collections. Combined with Established & Sons' commitment to skilled craftsmanship and cutting-edge manufacturing techniques, this produces intelligent designs that are at the same time diverse in the extreme and united in their quest for the extraordinary.

The Established & Sons collection includes some of the most important examples of 21st-century design. Many of the pieces have been acquired by international museums, galleries, institutions and private collections.

Follow us on [Instagram](#)