

Renascimento II

Dudu

História da Arte

Difusão do renascimento:

- ➔ Outras regiões: preocupação com questões de ordem prática e ética



Hyeronimus Bosch:

- ➔ Temas religiosos: céu e inferno, pecado e salvação...
- ➔ Foge das representações convencionais dos “demônios”
- ➔ Seu estilo serviu de inspiração para o Surrealismo do século XX





Peter Brueghel:

- ➔ Representações das realidades cotidianas (profundidade e zombaria)



Albrecht Dürer:

➔ Grande preocupação com os traços reais nas pinturas

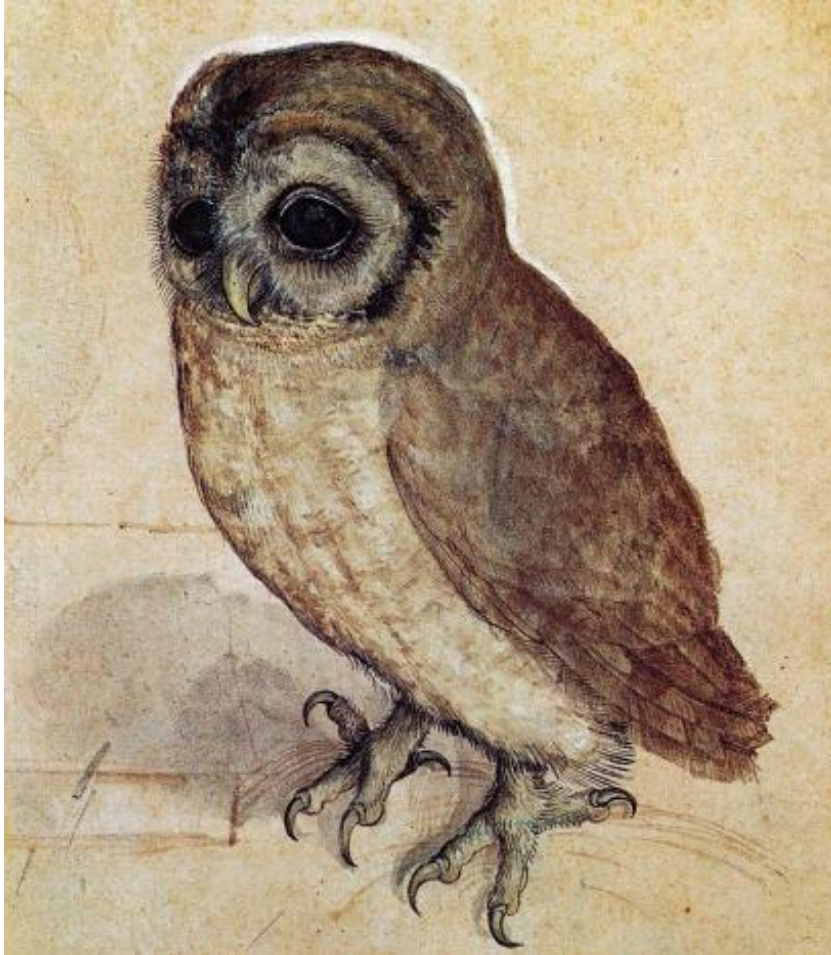

Arquitetura:

- ➔ Construções sobre módulos quadrados com proporções harmônicas e uniformes
- ➔ Cruz grega no lugar da cruz latina
- ➔ Retomada de itens da arquitetura grego-romana

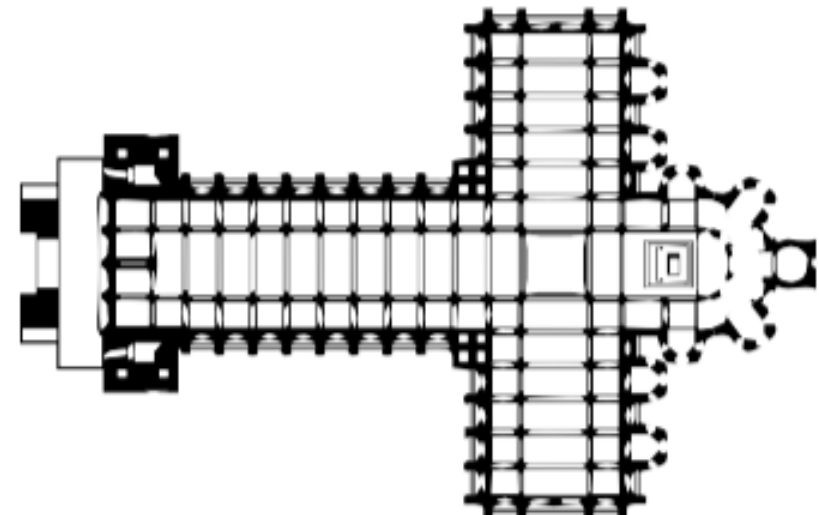
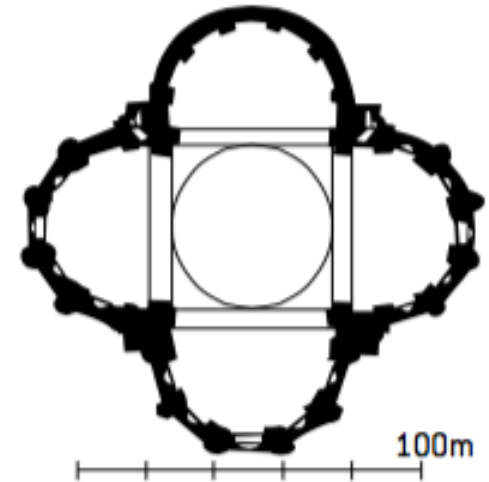

Felippo Brunelleschi:



Escultura:

- ➔ Influência dos estudos de anatomia e geometria
- ➔ Representação das ideias clássicas de beleza
- ➔ Principais nomes: Donatello e Michelangelo



David (Donatello e Michelangelo)



Pietà:



Literatura:

