

CSP 406 T/EN CSP 412 T/EN

IN-CEILING SPEAKER

Description

Metal ceiling fixture for voice alarm systems

These speaker units have been developed specifically for use in emergency and evacuation systems and each has its own ceramic terminal strip and thermal fuse. These ensure the protection of the line connecting the loudspeakers if a fire puts one or more of the speaker units connected to it out of use. The spring-based fixing system and the bayonet coupling cut the installation time. This ceiling fixture has a steel flame-proof cap, in order to comply with fire-fighting safety standards.

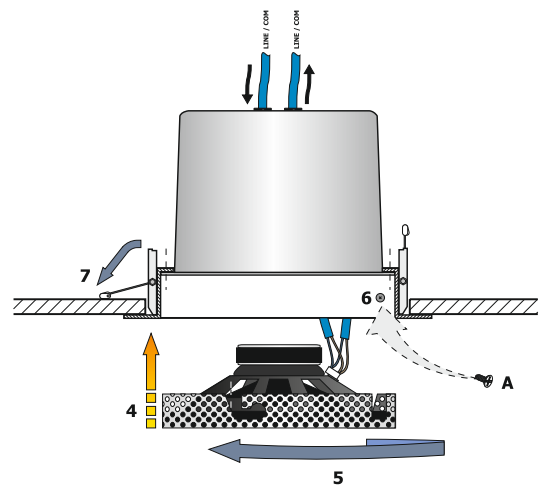

Technical data

CSP 406T/EN



--- 500 Hz
 — 1000 Hz
 - - - 2000 Hz
 — 4000 Hz

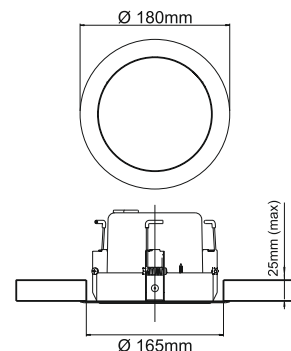
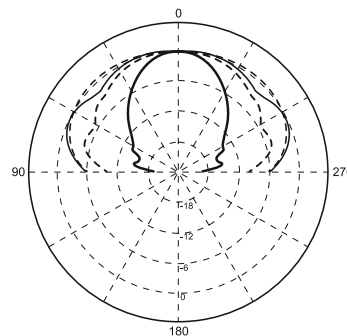

CSP 412T/EN

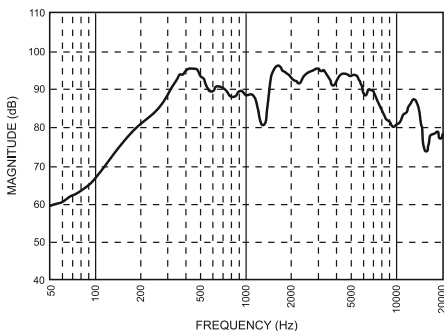

--- 500 Hz
 — 1000 Hz
 - - - 2000 Hz
 — 4000 Hz

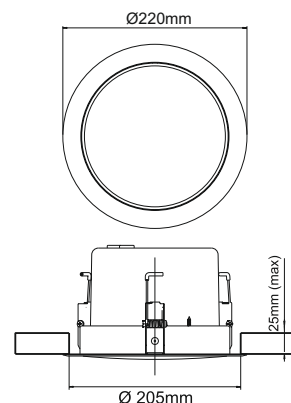
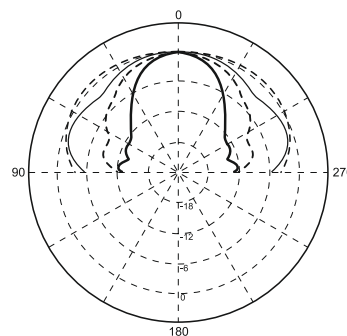

Misure effettuate in campo libero simulato.

| MODEL | CSP 406 T/EN | CSP 412 T/EN |
|--|---|---|
| Certificate | 0068 FBT Elettronica SpA - Via Paolo Soprani 1 62019 RECANATI (MC) 13 0068-CPR-033/2013 EN 54-24 Loudspeaker for voice alarm systems for fire detection and fire alarm systems for buildings CSP 406 T/EN Type A | 0068 FBT Elettronica SpA - Via Paolo Soprani 1 62019 RECANATI (MC) 13 0068-CPR-033/2013 EN 54-24 Loudspeaker for voice alarm systems for fire detection and fire alarm systems for buildings CSP 412 T/EN Type A |
| Rated output | 6 W (100 V) | 12 W (100 V) |
| Nominal impedance (100 V line) | 1667 Ω (6W) 3333 Ω (3W) 6667 Ω (1.5W) | 833 Ω (12W) 1667 Ω (6W) 3333 Ω (3W) |
| Nominal impedance (70 V line) | 817 Ω (6W) 1633 Ω (3W) 3267 Ω (1.5W) | 408 Ω (12W) 817 Ω (6W) 1633 Ω (3W) |
| Sensitivity | 92 dB (1W/1m) | 94 dB (1W/1m) |
| Max. sound pressure SPL* | 100 dB (6W/1m) | 105 dB (12W/1m) |
| Frequency response | 350 ÷ 15.000 Hz (peak -10 dB) | 250 ÷ 15.000 Hz (peak -10 dB) |
| Horizontal angle of dispersion (-6 dB) | 180° (500 Hz) 180° (1 kHz) 160° (2 kHz) 70° (4 kHz) | 180° (500 Hz) 180° (1 kHz) 110° (2 kHz) 60° (4 kHz) |
| Vertical angle of dispersion (-6 dB) | 180° (500 Hz) 180° (1 kHz) 160° (2 kHz) 70° (4 kHz) | 180° (500 Hz) 180° (1 kHz) 110° (2 kHz) 60° (4 kHz) |
| Operating / storage temperature | -25°C ÷ +55°C / -40°C ÷ 70°C | |
| Relative humidity | < 95% | |
| Mounting hole | ∅ 165 mm ^{±3} | ∅ 205 mm ^{±3} |
| Size | ∅ 180 mm | ∅ 220 mm |
| Weight (inclusive of the flame-proof cap) | 1,6 kg | 2 kg |

* Measurement made at the geometric center of the loudspeaker.