

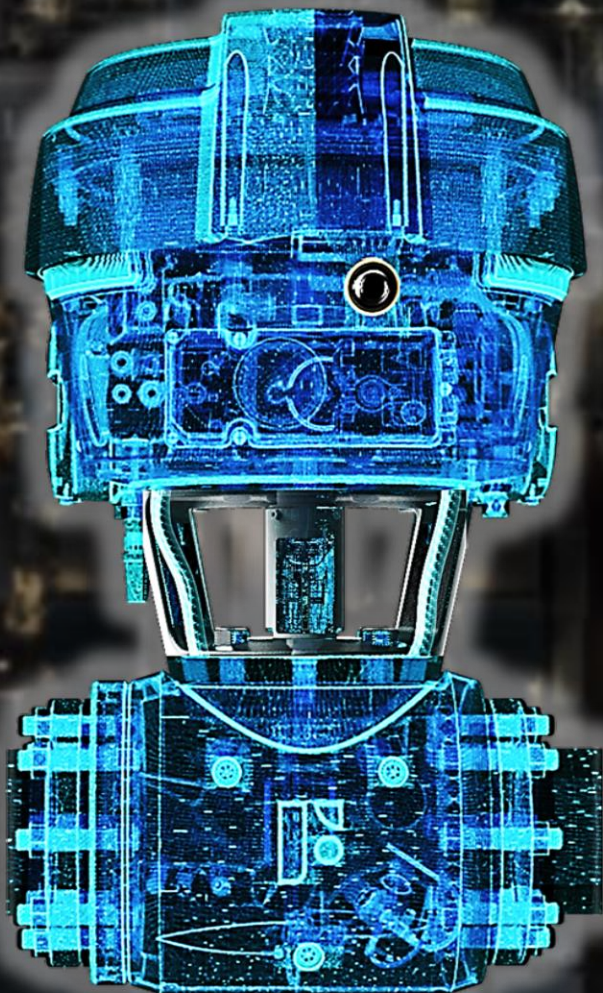

WELCOME TO THE WORLD OF **FOCUS-ON**



FOCUS-1 Case Studies

Enabling simplification across the automation pyramid to create value, in brownfield today and greenfield tomorrow

FOCUS-ON VoF

A SAMSON & KROHNE COMPANY
Kerkeplaat 12, 3313 LC Dordrecht, The Netherlands

www.focus-on-process.com | Info@fon-p.com
Customer Case Studies : 2021.12.12



CASE STUDY 2 - HEROS Sluiskil B.V.

FOCUS-1 gives an opportunity for faster and efficient control



APPLICATION

Flow Control into Tanks

Typical operating conditions for the FOCUS-1 device

| | | | |
|-----------------------|----|-------------|--------------------|
| Volumetric flow | Q | 10,0 - 15,0 | m ³ /hr |
| Upstream pressure | P1 | 2,0 | barg |
| Differential pressure | ΔP | 0,5 | bar |
| Temperature | T | 15,0 | °C |
| Density | ρ | 999 | kg/m ³ |
| Viscosity | η | 1,13 | mPas |

PROCESS LOOP as is today

Current setup has two control valves that do not control well. One of the reasons for this is because the traditional flow control loop can result in a lot of delay to control the flow properly as there is a big lag when the signal flows from a flowmeter to the controller and then back to the control valve.

FOCUS-1 changes the control philosophy

Replacement of a traditional control valve and flowmeter in each line with a DN80/PN10 FOCUS-1 utilized the decentralized flow control philosophy of FOCUS-1. This means that the inbuilt PID controllers in the device with the help of integrated flow measurement can directly calculate the correct opening/closing position of valve actuator to let appropriate flow happen through the device. This allowed HEROS to quickly integrate the product in the two control loops.

The ultimate result of using FOCUS-1 was faster and much efficient control without any lags in the loop. The customer just needs to input volumetric flow as a set-point (in m³/hr as 4/20mA signal) and FOCUS-1 works as a smart flow control device to provide flow control as well flow, pressure, and temperature measurement.

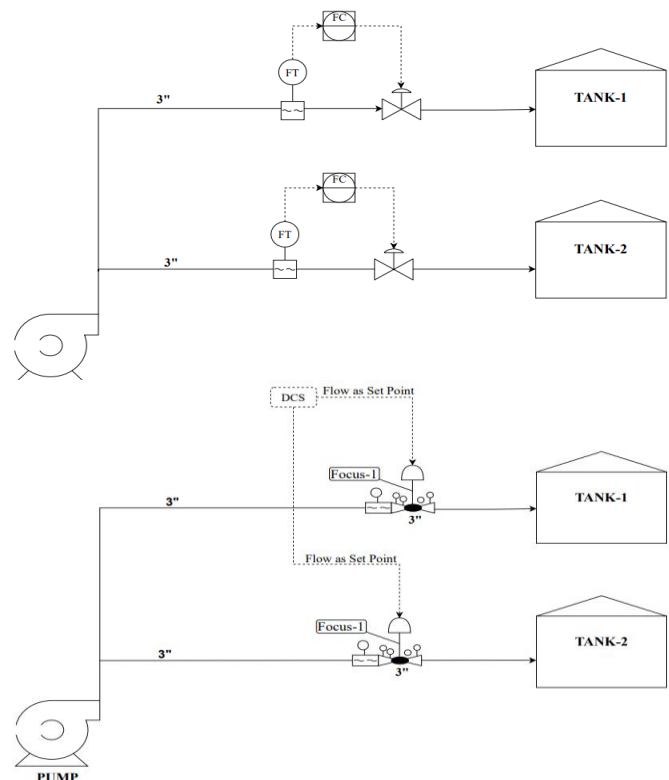
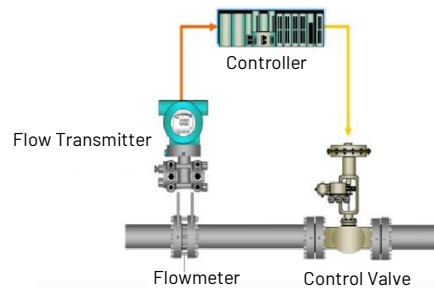

- FOCUS-1 (DN80 - PN10/40) has been innovated also keeping brownfield installations in mind.
- Standard face-to-face length
- Flow as set-point for better control
- Visual check of open position
- Flexible control options

FOCUS-1 benefits



Flow measurement along with flow control



Easy swap-in for better and faster control



Less dead band with flow as a set-point

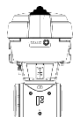

Flexibility of smart globe valve or smart control device

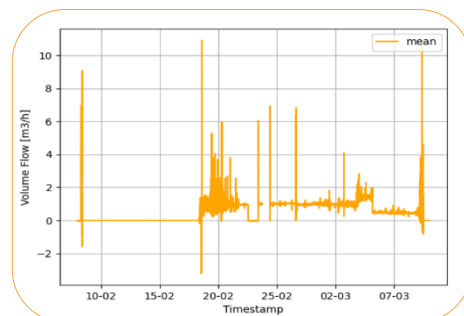

FOCUS-1 is "FLEXIBLE"

Monthly device performance reports showed that the flowrate at times was even lower than 5 m³/hr. As minimum velocity for FOCUS-1 to control based on flow is 3-5 m/s. At low flowrates, control on flow is not very efficient (going down a size is advisable here), but as FOCUS-1 can also work as normal control valve with valve position as set-point, the process did not face any problems at even low flow velocities.



FOCUS-1 Journey starts early in the plant to drive maximum value.

1

Integration of components

- allows reduced engineering and specification effort
- less flanges, shorter piping

→ up to 33% savings vs. traditional solution

2

Communication matters

- novel control philosophies reduce I/O & PLC/PID costs
- a valve 'finally' controls flow

→ better control quality and loop efficiency

3

Higher transparency on field

- customized alarms
- digital models need for mechanical redundancies in cases
- real-time view of device & process

4

→ powerful information enables optimization

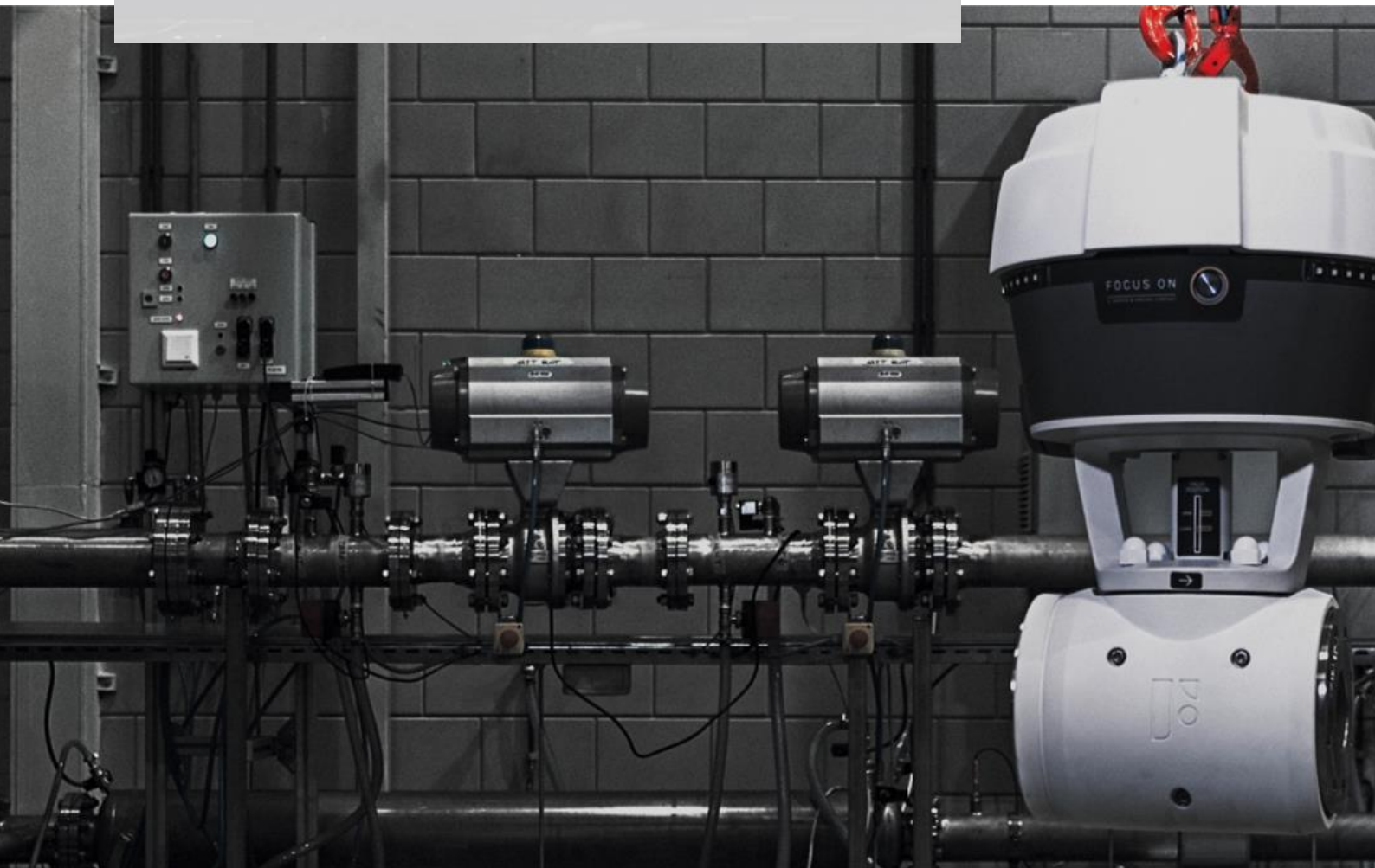
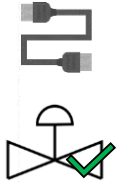
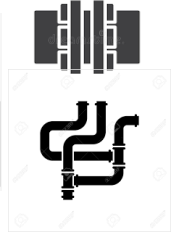



FOCUS-ON VoF

A SAMSON & KROHNE COMPANY
Kerkeplaat 12, 3313 LC Dordrecht, The Netherlands
K.v.K. 74863223

www.focus-on-process.com | Info@fon-p.com
Customer Case Studies : 2021.12.12