

EVOCOMFORT+

WALL FACE PAN

CODE: EV210

gallaria
intelligentbathrooms®



- Inclusions**
- ✓ EVOCOMFORT+ WALL FACE PAN with Intelligent Bidet Seat
 - ✓ Wireless remote control
 - ✓ Waste pipes
 - ✓ Water filter
 - ✓ Check valve/ball valve & inlet hose

- Features**
- Instantly heated water
 - Self-cleaning shower spray nozzle with rear and woman's wash functions, oscillating and pulsating spray, adjustable water temperature, water pressure and nozzle position
 - Air blower/dryer
 - Deodoriser
 - Built-in LED night light
 - Soft close seat
 - Rimless pan for reduced bacteria build-up
 - Fully concealed water and electrical connections (hidden from view)
 - Back-flow Prevention (air gap)
 - IPX4 Waterproof rating

- Note**
- Integrated Bidet Seat Complies with WMTS-051
- Bidet Seat includes integrated break tank with air gap, complying with AS 2845.2
 - Integrated high hazard back flow prevention device complies with installation standards outlined in AS/NZS 3500.1 without the need for a RPZ valve.

Notes for the installer

Setout: 80mm

The maximum water pressure for water supply is 500kpa.

Power supply requirements: Dedicated 10A, 220~240V AC, 50/60Hz supply

The water filter has a service life of approximately 12 months.

WELS: 0016 | 4 Stars Wels Rating

Connection to rain water or grey water is not recommended.

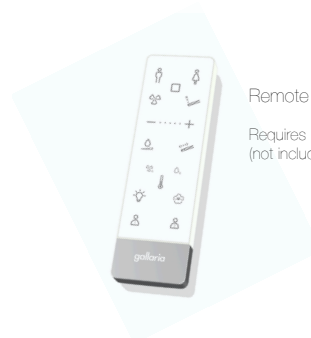
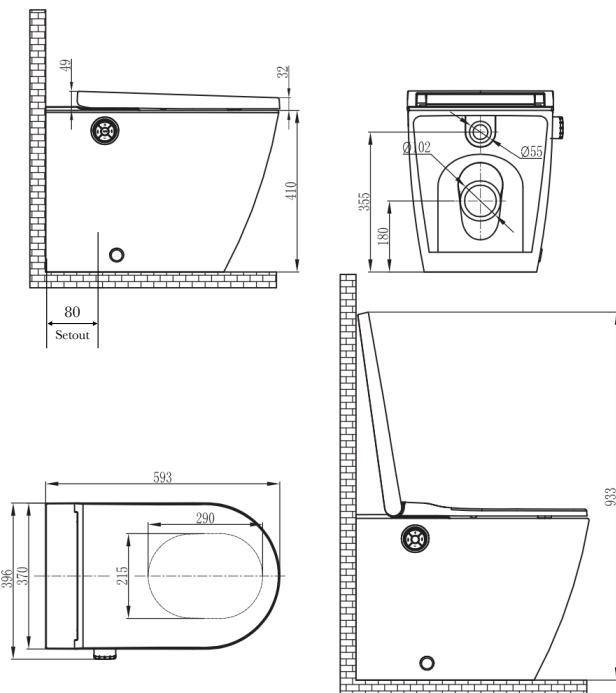

Remote Control (Included)

Requires 2 x AAA batteries (not included)

WELS: 0016
WM: 030025

WATER & ELECTRICAL CONNECTION DETAILS

IMPORTANT

ALL ELECTRICAL CONNECTIONS MUST BE INSTALLED BY A QUALIFIED ELECTRICIAN IN ACCORDANCE TO AS/NZS 3000.

The electrical components must be protected by a 10A Residual Circuit Breaker/RCD and a 10A magnothermic switch. Both switches **MUST** be located outside of the bathroom.

REAR VIEW



REAR VIEW

Electrical Connection Point

Hard-wiring recommended. No additional electrical equipment should be fitted within the WC cavity.

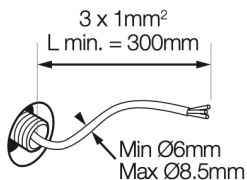

Note: Isolation Switch required

Electrical isolation switch should be located close to toilet, ideally hidden from view. For example, within bathroom vanity unit or shaving cabinet

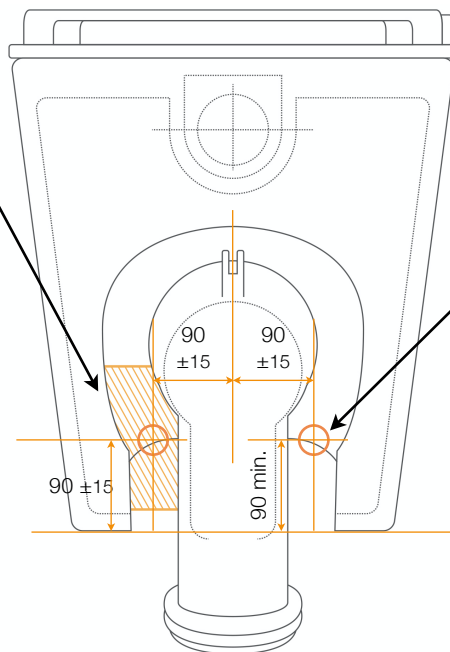

Water Connection Point

Water inlet
BSP thread

Note: Water Isolation Tap required

Water isolation mini-tap should be located close to toilet, ideally hidden from view. For example, within bathroom vanity unit or shaving cabinet.