

MAS⁺

Vertical



MAIN PRINTER UNITS

Printing bridges:

- Two printing units with carriage driven by linear motor.
- Double automatic cleaning stations, controlled from the operator panel•
Double capping station for carriage storage during printing pause

Unwinder:

- Axial driven unwinder with expanding shaft (3"- 74 mm core).
- Managed by compensation roll with pneumatic actuators, web tension is controlled by pressure regulator.
max. roll diameter 500 mm
max. roll weight 250 kg

Feeding roll:

- Rubber coated driven roll that manages the web feeding.
- Automatic media width detection

IR drying unit:

- 9 kW IR lamp device, power adjustable

Heated Air Drying unit:

- Drying device with two electrical fans, air heated by two electrical exchangers
- speed fans and heating power adjustable from panel operator

Winder:

- Axial driven winder with expanding shaft (3"- 74 mm core).
- Managed by compensation roll with pneumatic actuators, web tension is controlled by pressure regulator.
max. roll diameter 300 mm
max. roll weight 100 kg

Ink refueling system:

- 12 liters inks tank with ink min. level monitoring
- Refueling can be done also during printing process

Min: 900 mm - Max: 1850 mm

Print width:



Type of heads: **Kyocera KJ4B 600 dpi heads**

N° of carriage: **2**

Heads per carriage: **Up to 8**

Installable colors: **Nr. min 4 - max 8**

Rear side drying unit: **IR panel (9kW)**

Both sides drying unit: **Forced Air heater (18kW)**

maximum operating temperature: **80 ° C**

Sewing machine: **On Board (Optional)**

Centering device: **On Board (Optional)**

Image processor: **Built in**

Power Supply: **400 V Triphase**

Installed power: **44 kW**

Pneumatic user: **6 Bars**

Maximum compressed air consumption: **20L / min**

PRINTER LAYOUT

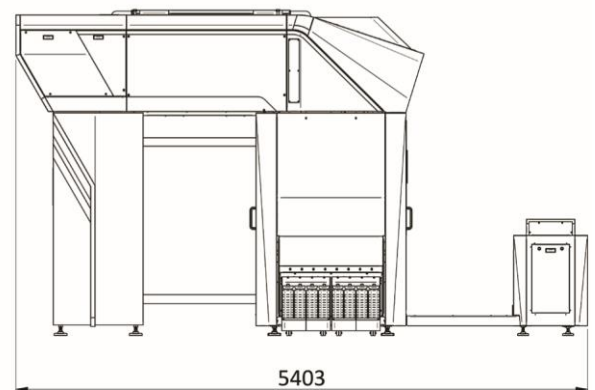
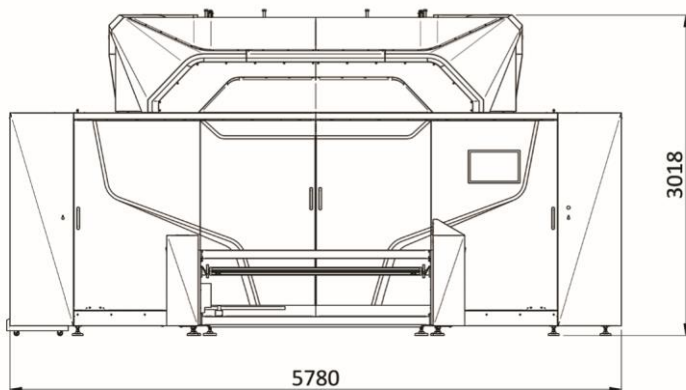

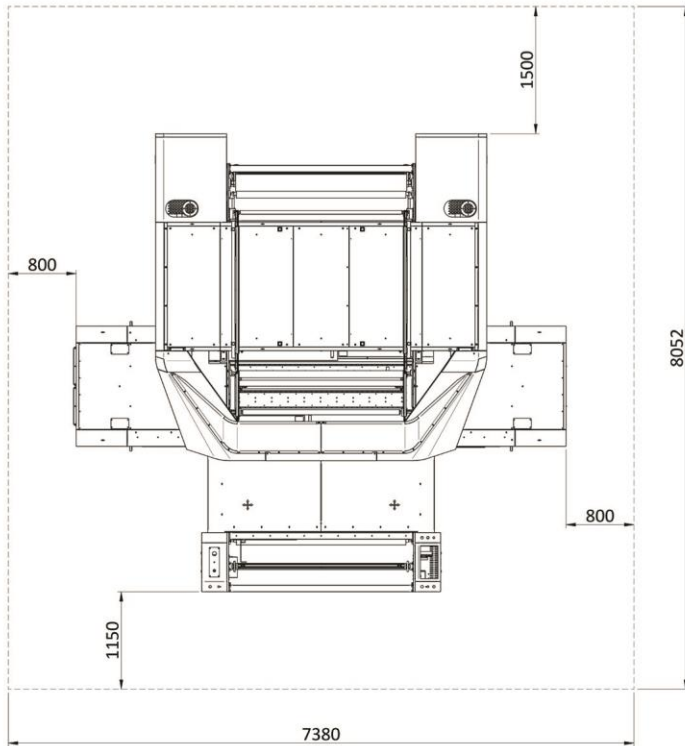

**Minimum
working area**

Exhauster exits

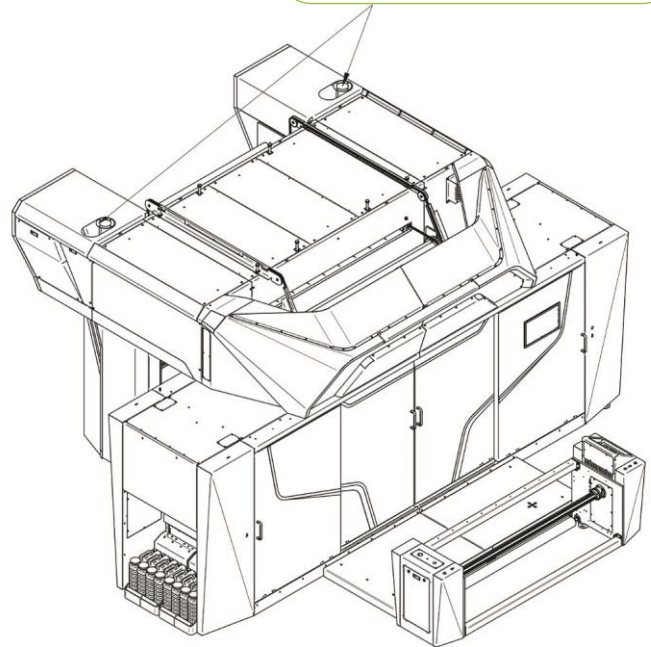

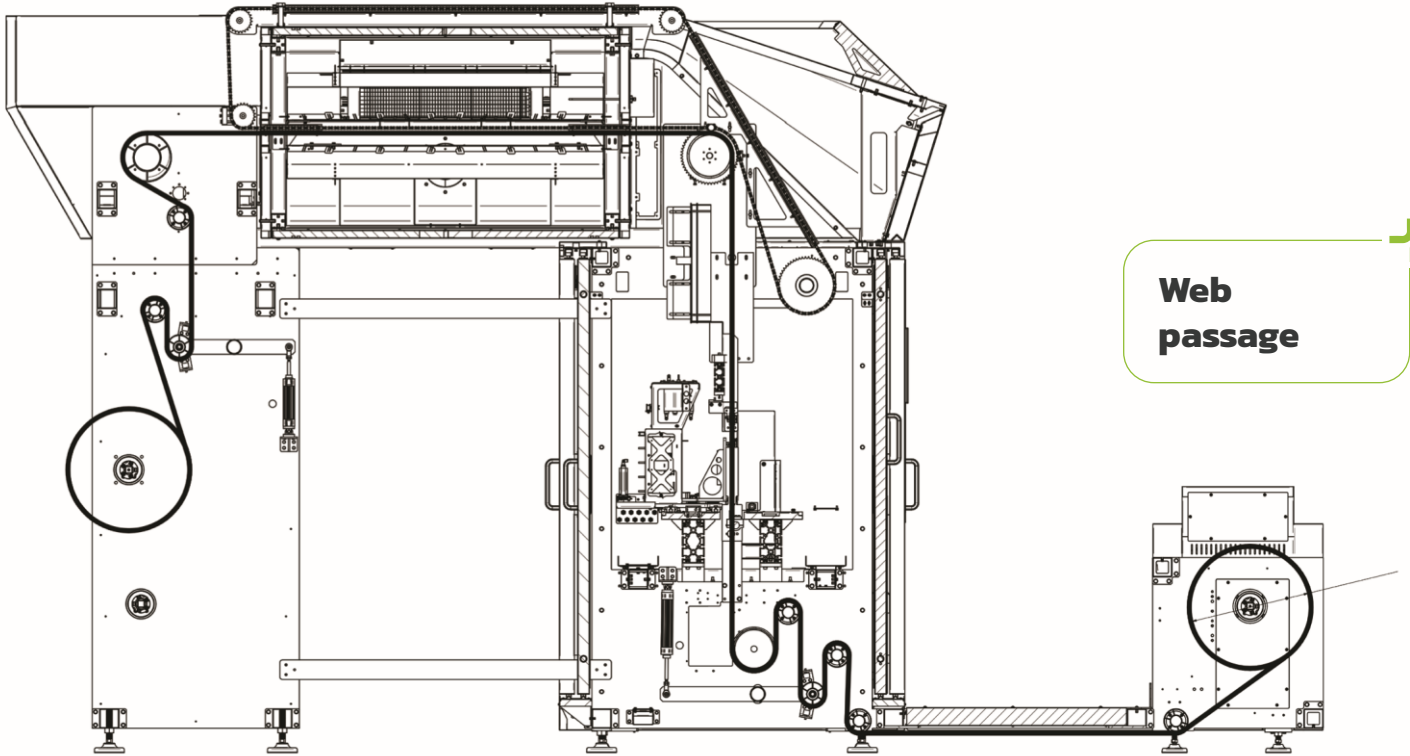

**Web
passage**

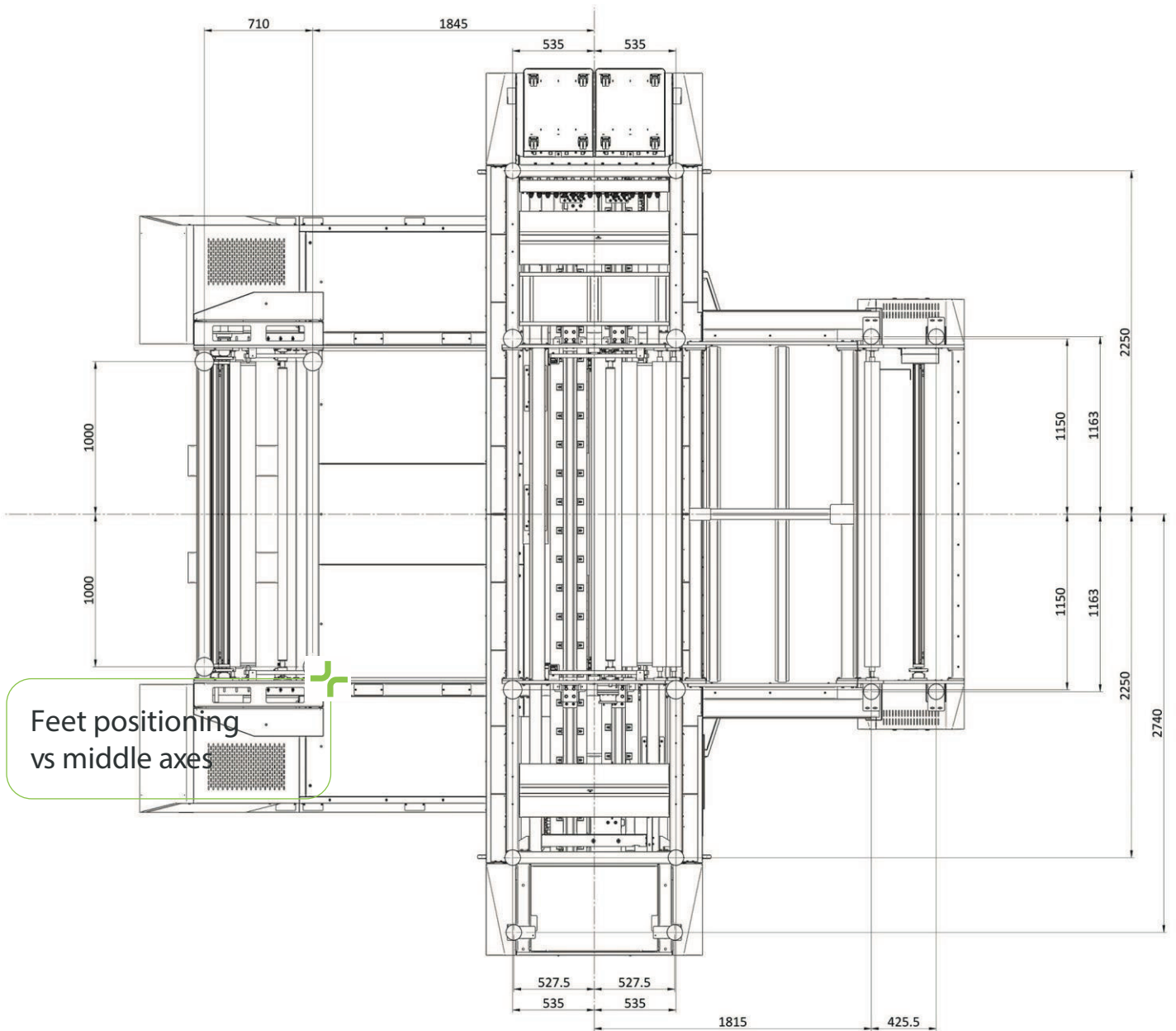

GD Gandy Digital
design · develop · produce

T: +32 2 42 04 129
M: +32 484 142 282
✉ shmulik@gandydigital.com
📍 Leuvensesteenweg 510, Building 11
1930 Zaventem, Belgium



www.gandydigital.com