

LEGEND

———— Partition to be removed

EXISTING LAYOUT

GENERAL NOTE:
 • ALL DIMENSIONS SHALL BE VERIFIED ON SITE BEFORE EXECUTION

REVISIONS

NO:	DESCRIPTION	DATE

DATE: 15.11.2022

PROJECT NAME:
 REFURBISHMENT OF SED OFFICE

LOCATION:
 MINISTRY OF ECONOMIC DEVELOPMENT,
 VELAANAAGE IITH FLOOR

CLIENT:
 MINISTRY OF ECONOMIC DEVELOPMENT

DRAWING NO:
 A-1.00

PREPARED BY:

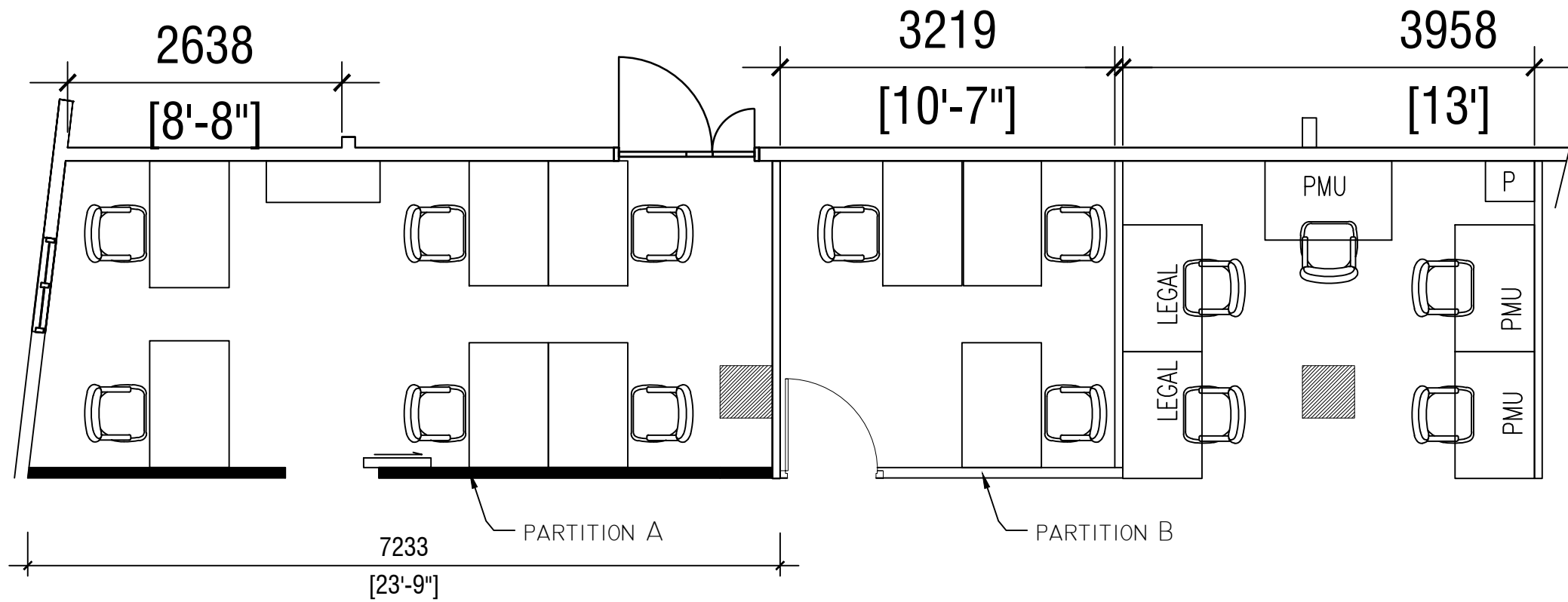

LEGEND

█ New partition

REVISED LAYOUT

GENERAL NOTE:
 • ALL DIMENSIONS SHALL BE VERIFIED ON SITE BEFORE EXECUTION

REVISIONS

NO:	DESCRIPTION	DATE

DATE: 15.11.2022

PROJECT NAME:
REFURBISHMENT OF SED OFFICE

LOCATION:
MINISTRY OF ECONOMIC DEVELOPMENT,
VELAANAAGE IITH FLOOR

CLIENT:
MINISTRY OF ECONOMIC DEVELOPMENT

DRAWING NO:
A-1.01

PREPARED BY:

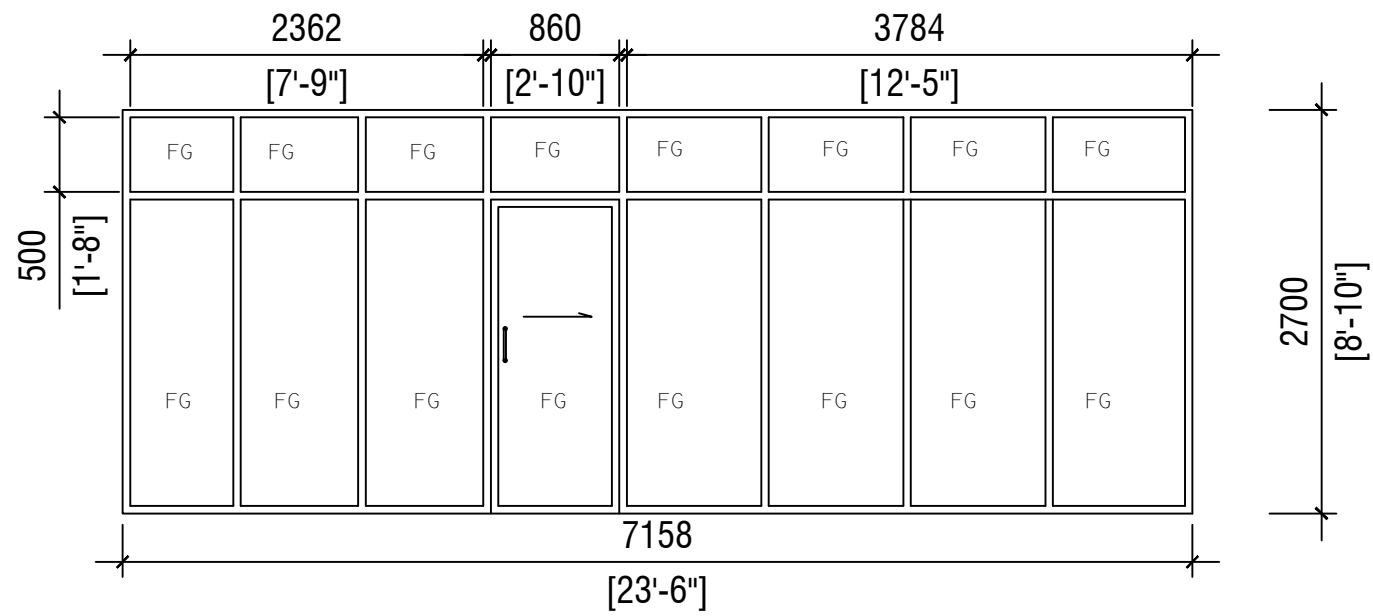

PARTITION A

NOTE:
 GSD - GLASS SLIDING DOOR
 FG - FIXED GLASS PANEL
 GLASS THICKNESS TO BE 6MM
 ALL MEASUREMENTS TO BE CONFIRMED BEFORE EXECUTION

GLASS PARTITION WITH SLIDING DOOR

GENERAL NOTE: • ALL DIMENSIONS SHALL BE VERIFIED ON SITE BEFORE EXECUTION		
REVISIONS		
NO:	DESCRIPTION	DATE
DATE: 15.II.2022		
PROJECT NAME: REFURBISHMENT OF SED OFFICE		
LOCATION: MINISTRY OF ECONOMIC DEVELOPMENT, VELAANAAGE 11TH FLOOR		
CLIENT: MINISTRY OF ECONOMIC DEVELOPMENT		
DRAWING NO: A-1.03		
PREPARED BY:		

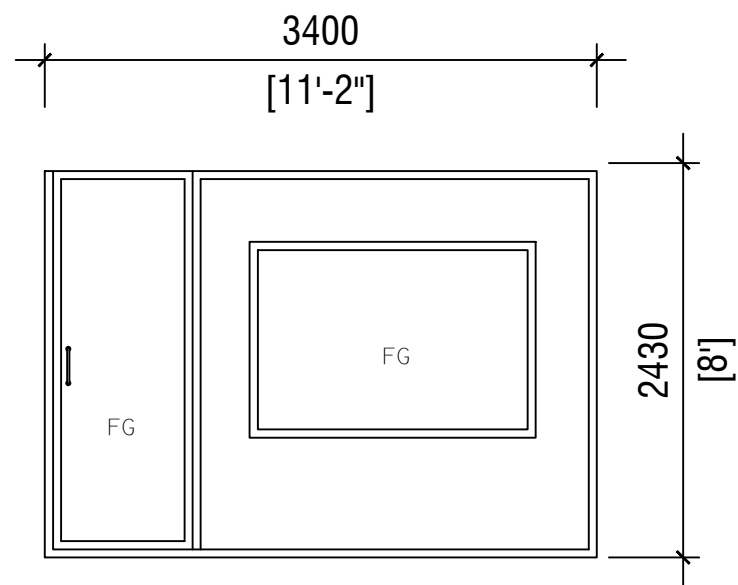

PARTITION B

EXISTING PARTITION

NOTE:
 GSD - GLASS SLIDING DOOR
 FG - FIXED GLASS PANEL
 GLASS THICKNESS TO BE 6MM
 ALL MEASUREMENTS TO BE CONFIRMED BEFORE EXECUTION

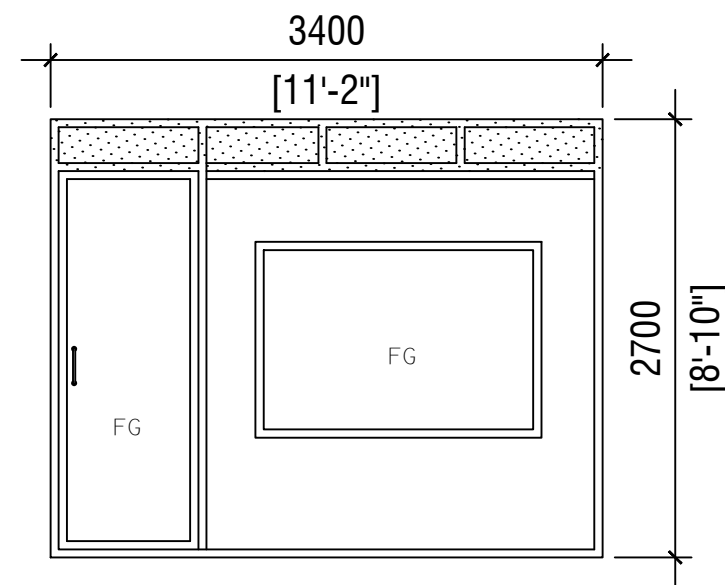

LEGEND

 Partition to be added

PARTITION B

REVISED PARTITION UP TO CEILING HEIGHT

NOTE:
 GSD - GLASS SLIDING DOOR
 FG - FIXED GLASS PANEL
 GLASS THICKNESS TO BE 6MM
 ALL MEASUREMENTS TO BE CONFIRMED BEFORE EXECUTION

GENERAL NOTE:
 • ALL DIMENSIONS SHALL BE VERIFIED ON SITE BEFORE EXECUTION

REVISIONS		
NO:	DESCRIPTION	DATE

DATE: 15.II.2022

PROJECT NAME:
 REFURBISHMENT OF SED OFFICE

LOCATION:
 MINISTRY OF ECONOMIC DEVELOPMENT,
 VELAANAAGE IITH FLOOR

CLIENT:
 MINISTRY OF ECONOMIC DEVELOPMENT

DRAWING NO:
 A-1.03

PREPARED BY: