

- ސަލާމަތް ސަލާމަތް ސަލާމަތް ސަލާމަތް ސަލާމަތް 40 ގަޅި ގަޅި ގަޅި
- ސަލާމަތް ސަލާމަތް ސަލާމަތް ސަލާމަތް ސަލާމަތް 50 ގަޅި ގަޅި ގަޅި

ސަލާމަތް ސަލާމަތް ސަލާމަތް

- ސަލާމަތް ސަލާމަތް ސަލާމަތް ސަލާމަތް ސަލާމަތް 150 ގަޅި ގަޅި ގަޅި
- ސަލާމަތް ސަލާމަތް ސަލާމަތް ސަލާމަތް ސަލާމަތް 1:4 (1 ސަލާމަތް، 4 ސަލާމަތް)
- ސަލާމަތް ސަލާމަތް ސަލާމަތް ސަލާމަތް ސަލާމަތް ސަލާމަތް ސަލާމަތް ސަލާމަތް
- ސަލާމަތް ސަލާމަތް ސަލާމަތް ސަލާމަތް ސަލާމަތް 1:3 (1 ސަލާމަތް، 3 ސަލާމަތް)
- ސަލާމަތް ސަލާމަތް ސަލާމަތް ސަލާމަތް ސަލާމަތް 1:3 (1 ސަލާމަތް، 3 ސަލާމަތް)
- ސަލާމަތް ސަލާމަތް ސަލާމަތް ސަލާމަތް ސަލާމަތް 20 ގަޅި ގަޅި ގަޅި
- ސަލާމަތް ސަލާމަތް ސަލާމަތް ސަލާމަތް ސަލާމަތް 50 ގަޅި ގަޅި ގަޅި
- ސަލާމަތް ސަލާމަތް ސަލާމަތް ސަލާމަތް ސަލާމަތް ސަލާމަތް ސަލާމަތް ސަލާމަތް

ސަލާމަތް ސަލާމަތް ސަލާމަތް

- ސަލާމަތް ސަލާމަތް ސަލާމަތް ސަލާމަތް ސަލާމަތް 50 ގަޅި ގަޅި ގަޅި
- ސަލާމަތް ސަލާމަތް ސަލާމަތް ސަލާމަތް ސަލާމަތް 38 ގަޅި ގަޅި ގަޅި
- ސަލާމަތް ސަލާމަތް ސަލާމަތް ސަލާމަތް ސަލާމަތް 80 ގަޅި ގަޅި ގަޅި
- ސަލާމަތް ސަލާމަތް ސަލާމަތް ސަލާމަތް ސަލާމަތް 6 ގަޅި ގަޅި ގަޅި
- ސަލާމަތް ސަލާމަތް ސަލާމަތް ސަލާމަތް ސަލާމަތް ސަލާމަތް ސަލާމަތް ސަލާމަތް
- ސަލާމަތް ސަލާމަތް ސަލާމަތް ސަލާމަތް ސަލާމަތް 0.5 ގަޅި ގަޅި ގަޅި
- ސަލާމަތް ސަލާމަތް ސަލާމަތް ސަލާމަތް ސަލާމަތް 2.5 ގަޅި ގަޅި ގަޅި
- ސަލާމަތް ސަލާމަތް ސަލާމަތް ސަލާމަތް ސަލާމަތް ސަލާމަތް ސަލާމަތް ސަލާމަތް

ސަރުކާރުގެ ދާއިރާތަކުން ޖަދުވަލު ދާއިރާއި ސަރުކާރުގެ ދާއިރާތަކުން
- ސަރުކާރުގެ ދާއިރާތަކުން ޖަދުވަލު ދާއިރާއި ސަރުކާރުގެ ދާއިރާތަކުން
- ސަރުކާރުގެ ދާއިރާތަކުން ޖަދުވަލު ދާއިރާއި ސަރުކާރުގެ ދާއިރާތަކުން



❖ **දි. 2019-04-01 දින සිට 2022-03-31 දක්වා**

විද්‍යා මණ්ඩල 10 ක් වන විද්‍යා මණ්ඩලයේ අධ්‍යක්ෂණ ජ්‍යෙෂ්ඨ මහත්මියගේ මාර්ගගත අධ්‍යයන මධ්‍යස්ථානයකින් සාමාන්‍ය පන්ති 10 ක් කෙරෙහි වැඩිපුර කුලීන් අයවැන්නන්ගේ අවධානය යොමු කිරීම සඳහා 10,000.00 (එසිය දහස රුපියල් පමණ) ද මුදල් මුදා හරිනු ලබනු ඇත.

විද්‍යා මණ්ඩලයේ අධ්‍යක්ෂණ ජ්‍යෙෂ්ඨ මහත්මියගේ මාර්ගගත අධ්‍යයන මධ්‍යස්ථානයකින් සාමාන්‍ය පන්ති 60 ක් කෙරෙහි වැඩිපුර කුලීන් අයවැන්නන්ගේ අවධානය යොමු කිරීම සඳහා 10,000.00 (එසිය දහස රුපියල් පමණ) ද මුදල් මුදා හරිනු ලබනු ඇත.

විද්‍යා මණ්ඩලයේ අධ්‍යක්ෂණ ජ්‍යෙෂ්ඨ මහත්මියගේ මාර්ගගත අධ්‍යයන මධ්‍යස්ථානයකින් සාමාන්‍ය පන්ති 10 ක් කෙරෙහි වැඩිපුර කුලීන් අයවැන්නන්ගේ අවධානය යොමු කිරීම සඳහා 10,000.00 (එසිය දහස රුපියල් පමණ) ද මුදල් මුදා හරිනු ලබනු ඇත.

විද්‍යා මණ්ඩලයේ අධ්‍යක්ෂණ ජ්‍යෙෂ්ඨ මහත්මියගේ මාර්ගගත අධ්‍යයන මධ්‍යස්ථානයකින් සාමාන්‍ය පන්ති 10 ක් කෙරෙහි වැඩිපුර කුලීන් අයවැන්නන්ගේ අවධානය යොමු කිරීම සඳහා 10,000.00 (එසිය දහස රුපියල් පමණ) ද මුදල් මුදා හරිනු ලබනු ඇත.

විද්‍යා මණ්ඩලයේ අධ්‍යක්ෂණ ජ්‍යෙෂ්ඨ මහත්මියගේ මාර්ගගත අධ්‍යයන මධ්‍යස්ථානයකින් සාමාන්‍ය පන්ති 10 ක් කෙරෙහි වැඩිපුර කුලීන් අයවැන්නන්ගේ අවධානය යොමු කිරීම සඳහා 10,000.00 (එසිය දහස රුපියල් පමණ) ද මුදල් මුදා හරිනු ලබනු ඇත.

- (1) පිලිබදව ඇති විෂය මත පිළිබදව විස්තර ලබා දෙන ලදී.
- (2) පිලිබදව ඇති විෂය මත පිළිබදව විස්තර ලබා දෙන ලදී.
- (3) පිලිබදව ඇති විෂය මත පිළිබදව විස්තර ලබා දෙන ලදී.

විද්‍යා මණ්ඩලයේ අධ්‍යක්ෂණ ජ්‍යෙෂ්ඨ මහත්මියගේ මාර්ගගත අධ්‍යයන මධ්‍යස්ථානයකින් සාමාන්‍ය පන්ති 10 ක් කෙරෙහි වැඩිපුර කුලීන් අයවැන්නන්ගේ අවධානය යොමු කිරීම සඳහා 10,000.00 (එසිය දහස රුපියල් පමණ) ද මුදල් මුදා හරිනු ලබනු ඇත.

FENCING DETAIL

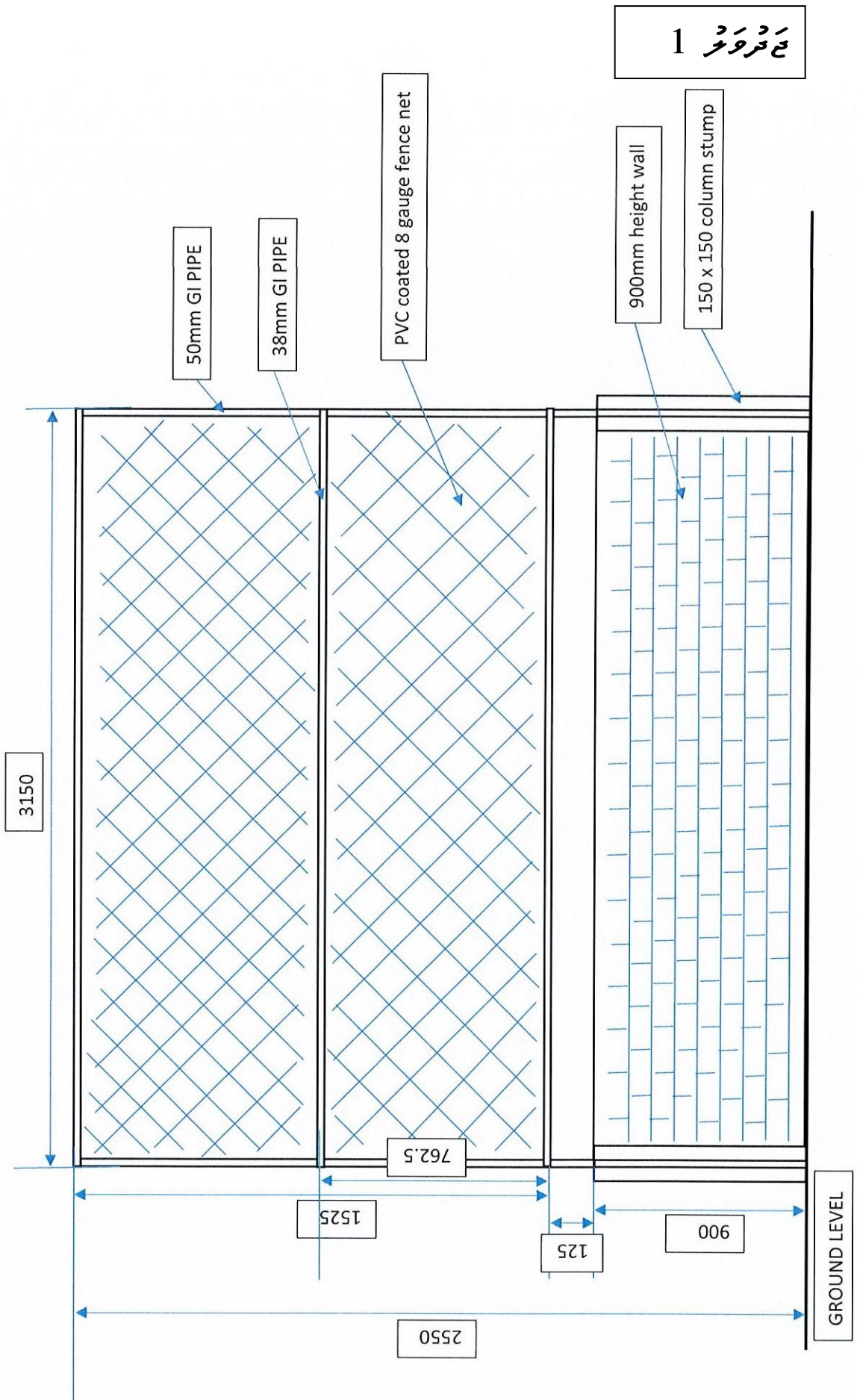

1

ބަނޑު 2

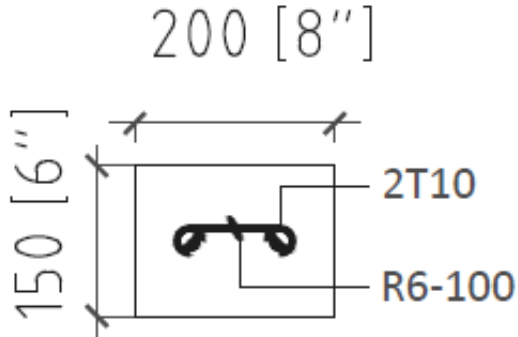

TOPICAL COLUMN

SCALE 1:10

3 ޖަދުވަލު

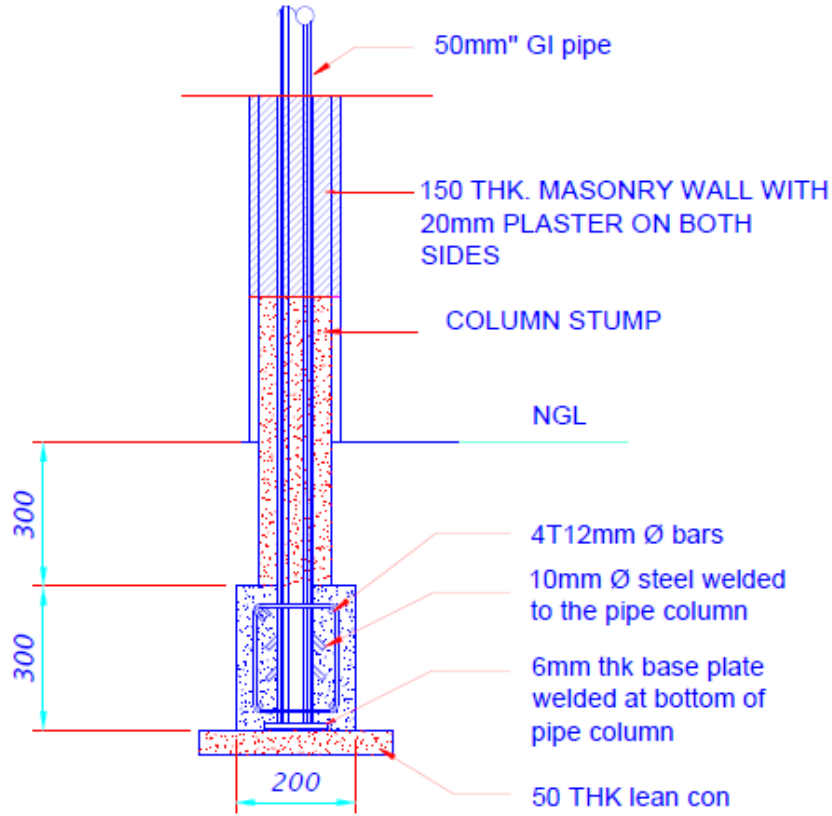

DETAL- COLUMN STUMP
 Scale - 1:20

ބޭނުންކުރާ 4

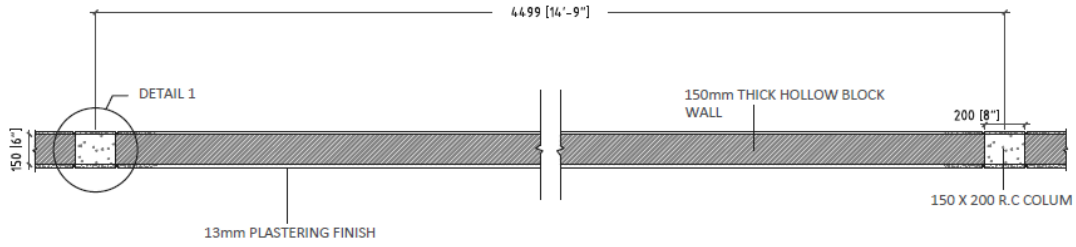

PLAN
 SCALE 1:8

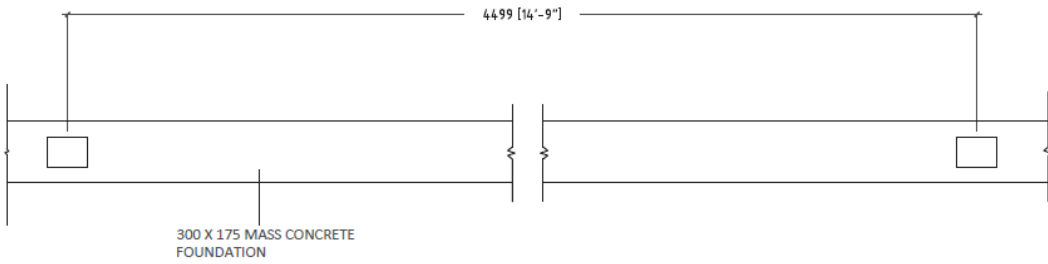

FOUNDATION PLAN
 SCALE 1:8

5th Floor Plan

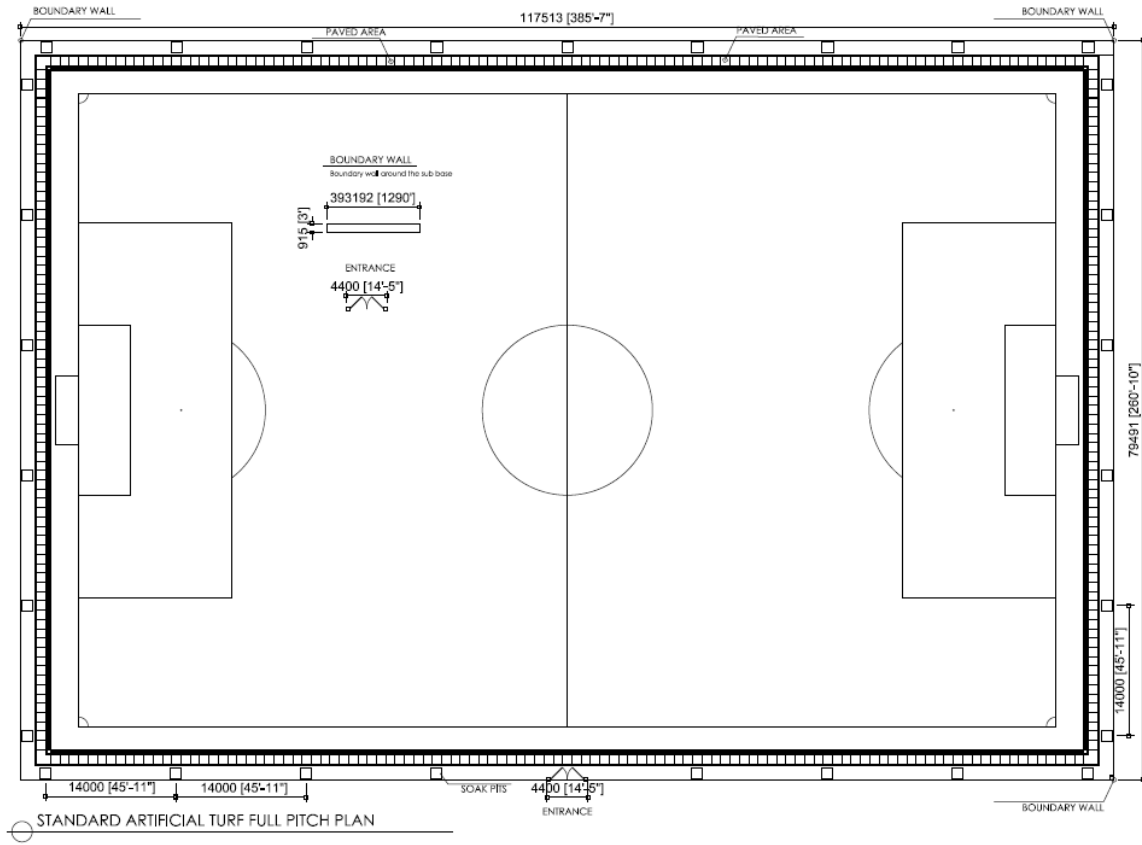

ޖަދުވަލު 6

MAIN GATE

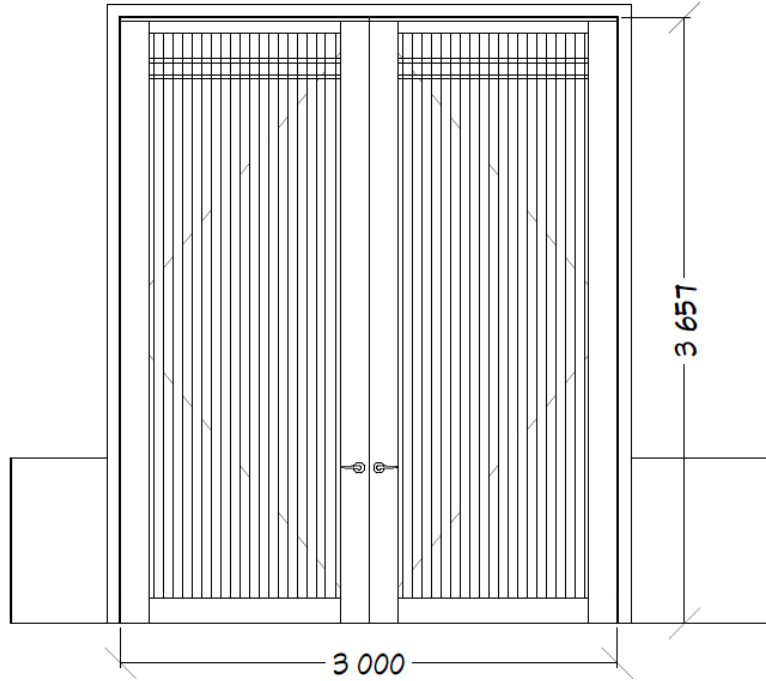

ޖަދުވަލު 7

Entrance Gate

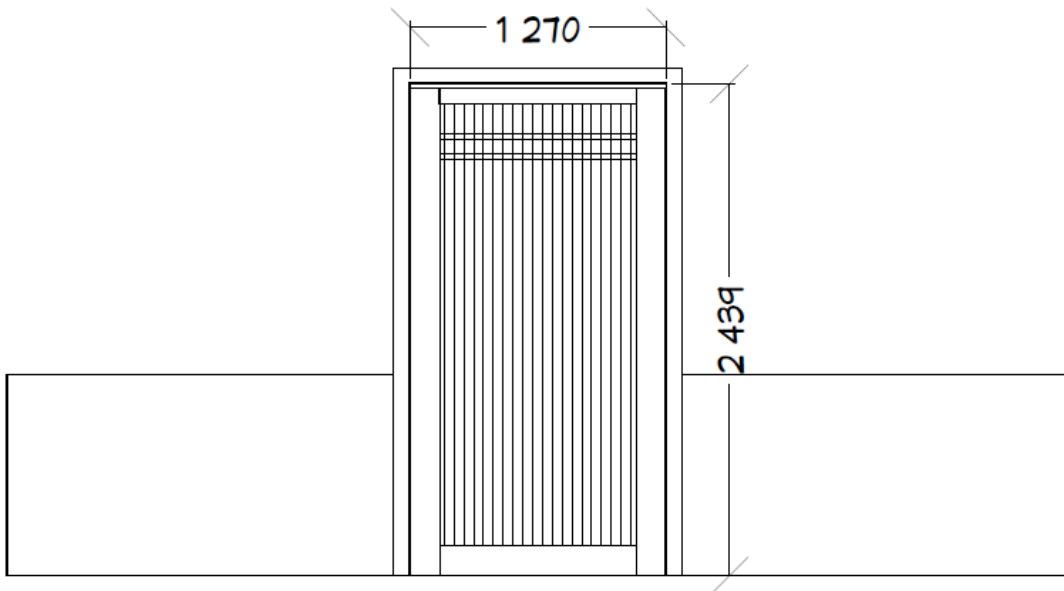

ޖަދުވަލު 8

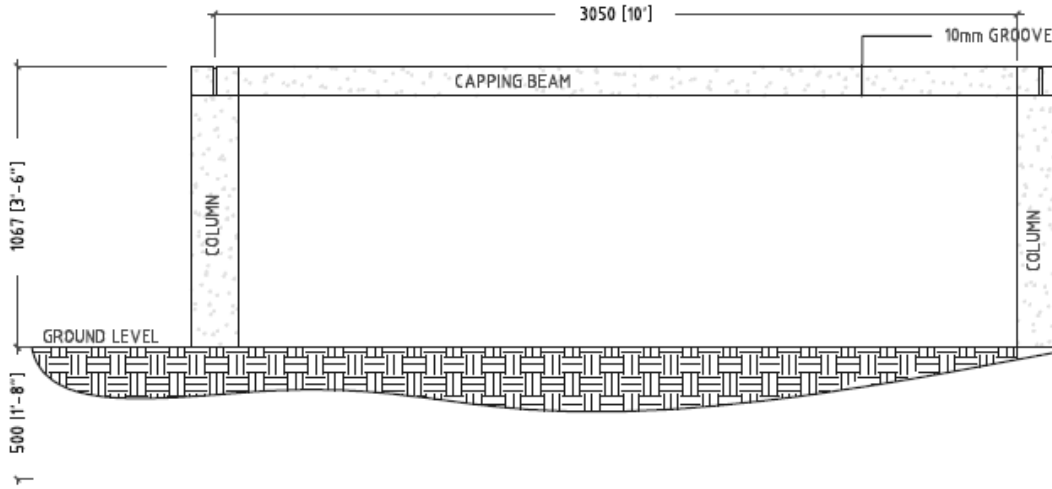

ELEVATION
SCALE 1:25

9 ޖަދުވަލު

FOOTBALL GROUND AS-BUILT FLOOR PLAN

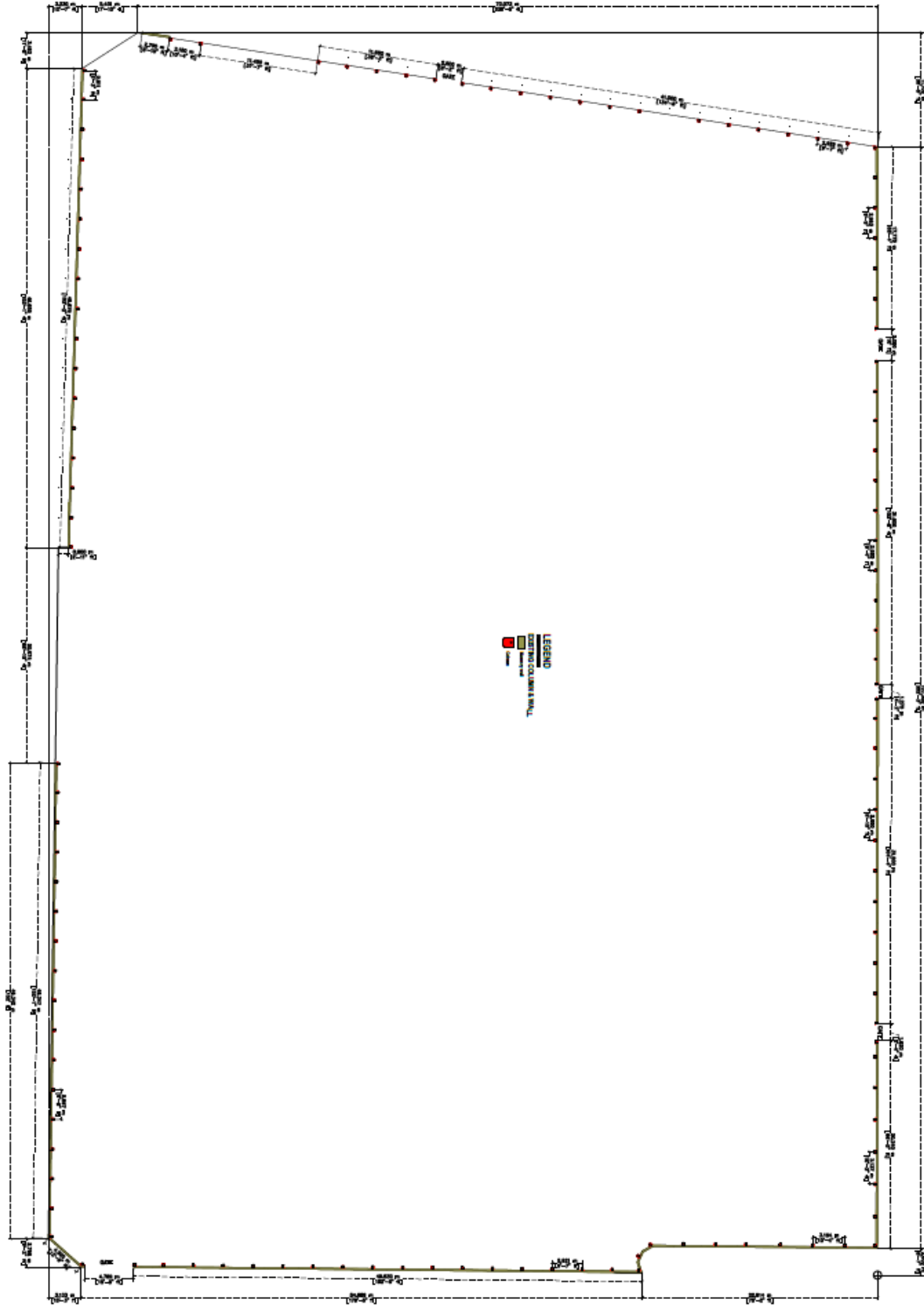

ސަފްޙާ 1

Bid Security Format

(Required under clause (7)(9) of the Bid Document of iulaan number: (IUL)341/341/2023/5)

Whereas [name of Bidder] (hereinafter called “the Bidder”) has submitted its Bid (Serial Number) dated [date of submission of Bid] for lease development and operation of a Guest House on the Plot of Land in the island of Ukulhas, in North Ari’ Atoll, Maldives more fully described in that Bid pursuant to the Invitation for Bids bearing IFB Number dated (hereinafter called “the Bid”);

KNOW ALL PEOPLE by these presents that WE [name of bank / financial institution] of [name of country], having our registered office at [address of bank], are bound unto the Government of Maldives represented by Ukulhas Council (hereinafter called “the Council”) in the sum of MVR 10.000/- (Ten thousand rufiyaa) for which payment well and truly to be made to the said Council, the Bank / financial institution binds itself, its successors, and assigns by these presents.

Sealed with the Common Seal of the said Bank / Financial Institution this _____ day of _____ 2022.

THE CONDITIONS of this obligation are:

A. If the Bidder:

- i. having been awarded a Notification of Award of the Bid by the Council during the period of Bid validity refuses to accept the Award for any reason
- ii. After being awarded the Notification of Award of the Bid by the Council during the period of Bid validity, refuses to fulfil the obligations required prior to signing the Agreement stated in the Bid Document of iulaan number: (IUL)341/341/2023/5
- iii. Refuses to sign the agreement during the period stated in the Bid Document of iulaan number: (IUL)341/341/2023/5

We undertake to pay to the Council the above amount upon receipt of its first written demand, without the Council having to substantiate its demand, provided that in its demand the Council will note that the amount claimed by it is owing to the occurrence of any of the above conditions.

This guarantee will remain in force up to and including [date:calendar days after Bid opening], and any demand in respect thereof should reach the Bank not later than the above date.

This guarantee shall be governed by and construed in accordance with the laws of the Republic of Maldives.

This guarantee shall supersede all agreements between this Bank / Financial Institution and the Bidder in relation to this Bid. If there are any inconsistencies between this guarantee and any other document exchanged between the Bank / Financial Institution and the Bidder, the terms of this guarantee shall prevail.

[Seal and signature of the bank/financial institution]

Performance Guarantee

[Guarantor letterhead or SWIFT identifier code]

Beneficiary: [insert name and Address of Employer]

Date: [Insert date of issue]

PERFORMANCE GUARANTEE No.: [Insert guarantee reference number]

Guarantor: [Insert name and address of place of issue, unless indicated in the letterhead]

We have been informed that _ [insert name of Contractor, which in the case of a joint venture shall be the name of the joint venture] (hereinafter called "the Applicant") has entered into Contract No. [insert reference number of the contract] dated [insert date] with the Beneficiary, for the execution of _ [insert name of contract and brief description of Works] (hereinafter called "the Contract").

Furthermore, we understand that, according to the conditions of the Contract, a performance guarantee is required.

At the request of the Applicant, we as Guarantor, hereby irrevocably undertake to pay the Beneficiary any sum or sums not exceeding in total an amount of [insert amount in figures] (_____) [insert amount in words],¹ such sum being payable in the types and proportions of currencies in which the Contract Price is payable, upon receipt by us of the Beneficiary's complying demand supported by the Beneficiary's statement, whether in the demand itself or in a separate signed document accompanying or identifying the demand, stating that the Applicant is in breach of its obligation(s) under the Contract, without the Beneficiary needing to prove therein or to show grounds for your demand or the sum specified.

¹ or a freely convertible currency acceptable to the Beneficiary.

² Insert the date twenty-eight days after the expected completion date as described in GCC Sub-Clause 57.1. The Employer should note that in the event of an extension of this date for completion of the Contract, the Employer would need to request an extension of this guarantee from the Guarantor. Such request must be in writing and must be made prior to the expiration date established in the guarantee. In preparing this guarantee, the Employer might consider adding the following text to the form, at the end of the penultimate paragraph: "The Guarantor agrees to a one-time extension of this guarantee for a period not to exceed [six months][one year], in response to the Beneficiary's written request for such extension, such request to be presented to the Guarantor before the expiry of the guarantee."

This guarantee shall expire, no later than the Day of, 2...², and any demand for payment under it must be received by us at this office indicated above on or before that date.

This guarantee is subject to the Uniform Rules for Demand Guarantees (URDG) 2010 Revision, ICC Publication No. 758, except that the supporting statement under Article 15(a) is hereby excluded.

[signature(s)]

Note: All italicized text (including footnotes) is for use in preparing this form and shall be deleted from the final product.



ދިވެހިސަރުކާރުގެ ގެޒެޓްގައި ވަނީ އާންމުކޮށް ބަޔާންކޮށްފައިވާ ގޮތުން

ސަރުކާރު

ޖެނަރޭޝަން	ބަޔާން	ޖަދުވަލު
80 %	ސަރުކާރުގެ ގަވާއިދުގެ ދަށުން ޖެނަރޭޝަން ފޮނުވަންނަންވާ ގޮތަށް (އިތުރު ޖެނަރޭޝަން)	1
10 %	ސަރުކާރުގެ ގަވާއިދުގެ ދަށުން ޖެނަރޭޝަން ފޮނުވަންނަންވާ ގޮތަށް (އިތުރު ޖެނަރޭޝަން)	2
10 %	ސަރުކާރުގެ ގަވާއިދުގެ ދަށުން ޖެނަރޭޝަން ފޮނުވަންނަންވާ ގޮތަށް (އިތުރު ޖެނަރޭޝަން)	3

އެއްވެސް ސަރުކާރުގެ ގަވާއިދުގެ ދަށުން ޖެނަރޭޝަން ފޮނުވަންނަންވާ ގޮތަށް 6660536 ނަންބަރުގައި ސަރުކާރުގެ ގަވާއިދުގެ ދަށުން ޖެނަރޭޝަން ފޮނުވަންނަންވާ ގޮތަށް hello@ukulhas.gov.mv ނަންބަރުގައި ސަރުކާރުގެ ގަވާއިދުގެ ދަށުން ޖެނަރޭޝަން ފޮނުވަންނަންވާ ގޮތަށް.



