



ބަލާ ޖަވާބު

ޖަވާބު ލިބޭގޮތަށް ސަރުކާރުގެ ގެޒެޓްގައި ބަލާ ޖަވާބު ލިބޭގޮތަށް ސަރުކާރުގެ ގެޒެޓްގައި ބަލާ ޖަވާބު ލިބޭގޮތަށް

އިދާރާތަކާއި ސަރުކާރުގެ ގެޒެޓްގައި ބަލާ ޖަވާބު ލިބޭގޮތަށް: (IUL)327-A/327/2023/104

ޖަވާބު ލިބޭގޮތަށް ސަރުކާރުގެ ގެޒެޓްގައި

އިދާރާތަކާއި ސަރުކާރުގެ ގެޒެޓްގައި ބަލާ ޖަވާބު ލިބޭގޮތަށް: 30 ޖުލައި 2023

މިއަދު ޖަވާބު ލިބޭގޮތަށް ސަރުކާރުގެ ގެޒެޓްގައި: 9 ޖުލައި 2023



سۆنمەن 1

پۆتەن مەنە

	پۆتەن مەنە
<p>پۆتەن مەنە 1</p> <p>سۆنمەن 1.1: 30 ئۆكتەبەر 2023</p> <p>(IUL)327-A/327/2023/104</p>	<p>1.1</p>
<p>2.1- 2023</p>	<p>2.3</p>
<p>پۆتەن مەنە 8.1</p> <p>پۆتەن مەنە 8.1: 7705700335001 (1370 ئۆكتەبەر 1)</p> <p>100.00 ئۆكتەبەر 7247788</p> <p>procurement@naifaru.gov.mv</p> <p>7247788</p> <p>info@naifaru.gov.mv</p> <p>6 ئۆكتەبەر 2023 (12:00)</p>	<p>8.1</p>
<p>پۆتەن مەنە 9.2</p> <p>7247788</p> <p>muzna.mohamed@naifaru.gov.mv</p> <p>info@naifaru.gov.mv</p>	<p>9.2</p>
<p>13.1</p>	<p>13.1</p>
<p>14</p>	<p>14</p>



<p> 18.1 10 10 2023 12:00 </p>	<p> 18.1 10 10 2023 12:00 </p>
<p> 20.1 10 10 2023 12:00 </p>	<p> 20.1 10 10 2023 12:00 </p>
<p> 24.1 </p>	<p> 24.1 </p>
<p> 28.1 </p>	<p> 28.1 </p>
<p> 28.2 </p>	<p> 28.2 </p>
<p> 30.1 </p>	<p> 30.1 </p>
<p> 36.1 </p>	<p> 36.1 </p>



...
...
...

3.3.1 3.3 3.3.1 ...

...
...
...

3.3.2 3.3.2 ...

...
...
...

3.3.2 3.3.2 ...

...
...
...

3.3.4 3.3.4 ...

...
...
...

3.3.5 3.3.5 ...

...
...
...

4.1 4.1 ...

...
...
...

5.1 5.1 ...

...
...
...

6.1 6.1 ...

...
...
...

...
...
...



3 - 3

33. 33.1 33.2 33.3 33.4 33.5

- 33.1 "33.1 33.2 33.3 33.4 33.5" 33.1 33.2 33.3 33.4 33.5
- 33.2 "33.2 33.3 33.4 33.5" 33.2 33.3 33.4 33.5
- 33.3 "33.3 33.4 33.5" 33.3 33.4 33.5
- 33.4 "33.4 33.5" 33.4 33.5
- 33.5 "33.5" 33.5

33. 33.1 33.2 33.3 33.4 33.5

- 34.1 34.2 34.3
- 34.2 34.3
- 34.3

34. 34.1 34.2 34.3

- 35.1 35.2
- 35.1 35.2

35. 35.1 35.2



ئاممەت ئۆزگەرتىش ھۆكۈمى

- ۱. سەر مەسئەل 40.30 سەئەتتە ھۆكۈم ئېلان قىلىشقا ھەممەي ئىشلىتىش ھۆكۈمى ئىشلىتىش ھۆكۈمى.
- ھۆكۈم ئېلان قىلىش ۋاقتىدا ھۆكۈم ئېلان قىلىشقا ھەممەي ئىشلىتىش ھۆكۈمى ئىشلىتىش ھۆكۈمى.
- ھۆكۈم ئېلان قىلىش ۋاقتىدا ھۆكۈم ئېلان قىلىشقا ھەممەي ئىشلىتىش ھۆكۈمى ئىشلىتىش ھۆكۈمى.
- ھۆكۈم ئېلان قىلىش ۋاقتىدا ھۆكۈم ئېلان قىلىشقا ھەممەي ئىشلىتىش ھۆكۈمى ئىشلىتىش ھۆكۈمى.
- ھۆكۈم ئېلان قىلىش ۋاقتىدا ھۆكۈم ئېلان قىلىشقا ھەممەي ئىشلىتىش ھۆكۈمى ئىشلىتىش ھۆكۈمى.
- ھۆكۈم ئېلان قىلىش ۋاقتىدا ھۆكۈم ئېلان قىلىشقا ھەممەي ئىشلىتىش ھۆكۈمى ئىشلىتىش ھۆكۈمى.
- ھۆكۈم ئېلان قىلىش ۋاقتىدا ھۆكۈم ئېلان قىلىشقا ھەممەي ئىشلىتىش ھۆكۈمى ئىشلىتىش ھۆكۈمى.
- ھۆكۈم ئېلان قىلىش ۋاقتىدا ھۆكۈم ئېلان قىلىشقا ھەممەي ئىشلىتىش ھۆكۈمى ئىشلىتىش ھۆكۈمى.
- ھۆكۈم ئېلان قىلىش ۋاقتىدا ھۆكۈم ئېلان قىلىشقا ھەممەي ئىشلىتىش ھۆكۈمى ئىشلىتىش ھۆكۈمى.
- ھۆكۈم ئېلان قىلىش ۋاقتىدا ھۆكۈم ئېلان قىلىشقا ھەممەي ئىشلىتىش ھۆكۈمى ئىشلىتىش ھۆكۈمى.



1 ڊسٽريڪٽ

(ٻي ڀاڱي جو ٻيو ڀاڱو)



lhnaifarucouncil



www.naifaru.gov.mv



info@naifaru.gov.mv



6620068



SECRETARIAT OF THE
FAADHIPOLHU

NAIFARU COUNCIL

PROJECT:

DEVELOPMENT OF A
BASHI COURT
AT LH. NAIFARU

DESIGNED BY:

ISMAIL YAMAAN YOOSUF
ARCHITECT
NAIFARU COUNCIL

CHECKED BY:

ASHHAM MOHAMED
ASSISTANT DIRECTOR
NAIFARU COUNCIL

APPROVED BY:

MOHAMED RASHEED
COUNCIL PRESIDENT
NAIFARU COUNCIL

DATE:

JANUARY 2022

DWG
NO:

01

SHEET
NO:

01

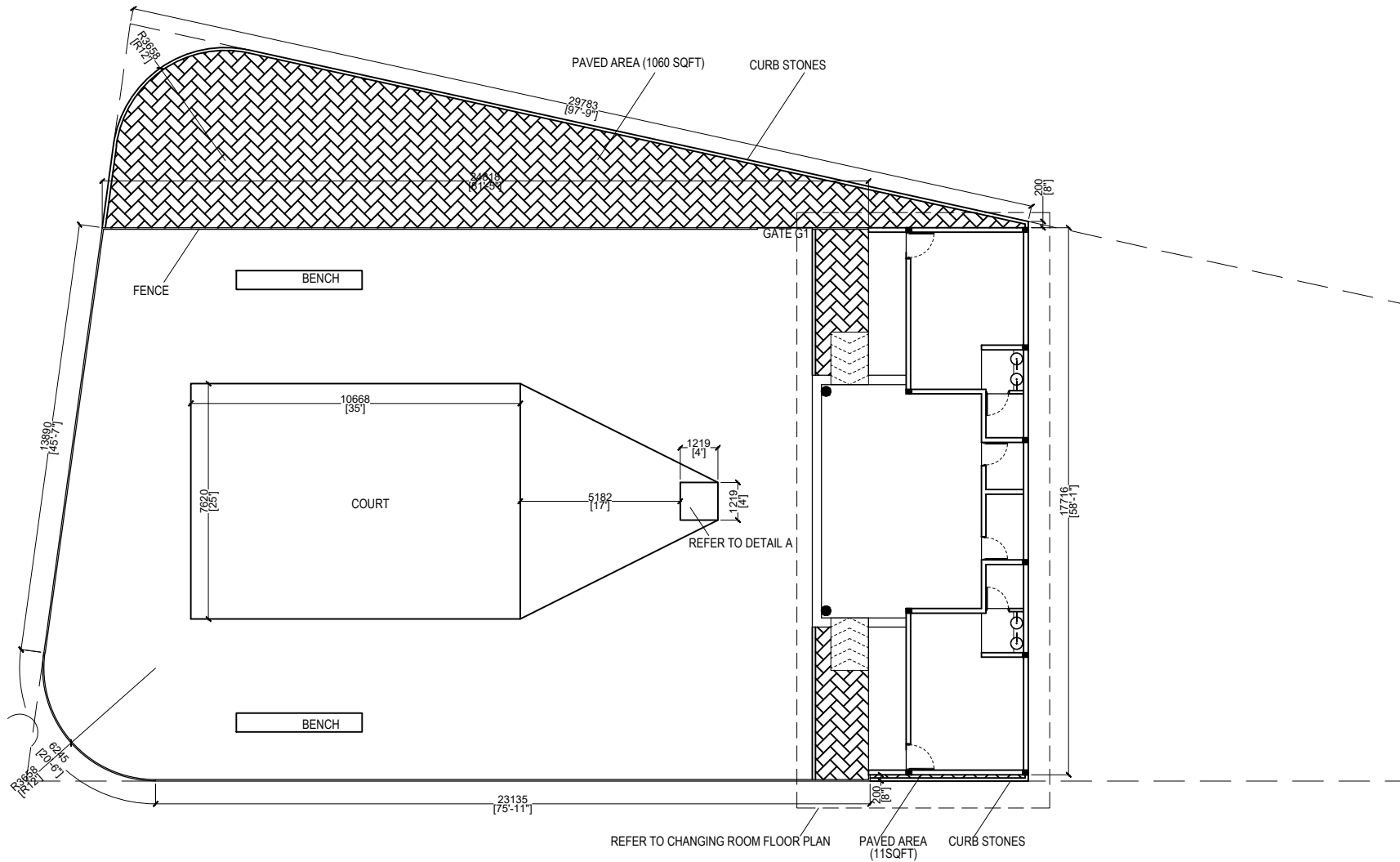

SITE PLAN

SCALE 1:200

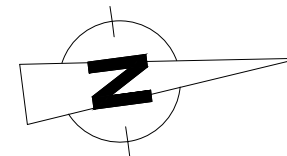



SECRETARIAT OF THE
FAADHIPOLHU

NAIFARU COUNCIL

PROJECT:

DEVELOPMENT OF A
BASHI COURT
AT LH. NAIFARU

DESIGNED BY:

ISMAIL YAMAAN YOOSUF
ARCHITECT
NAIFARU COUNCIL

CHECKED BY:

ASHHAM MOHAMED
ASSISTANT DIRECTOR
NAIFARU COUNCIL

APPROVED BY:

MOHAMED RASHEED
COUNCIL PRESIDENT
NAIFARU COUNCIL

DATE:

JANUARY 2022

DWG
NO:
02

SHEET
NO:
02

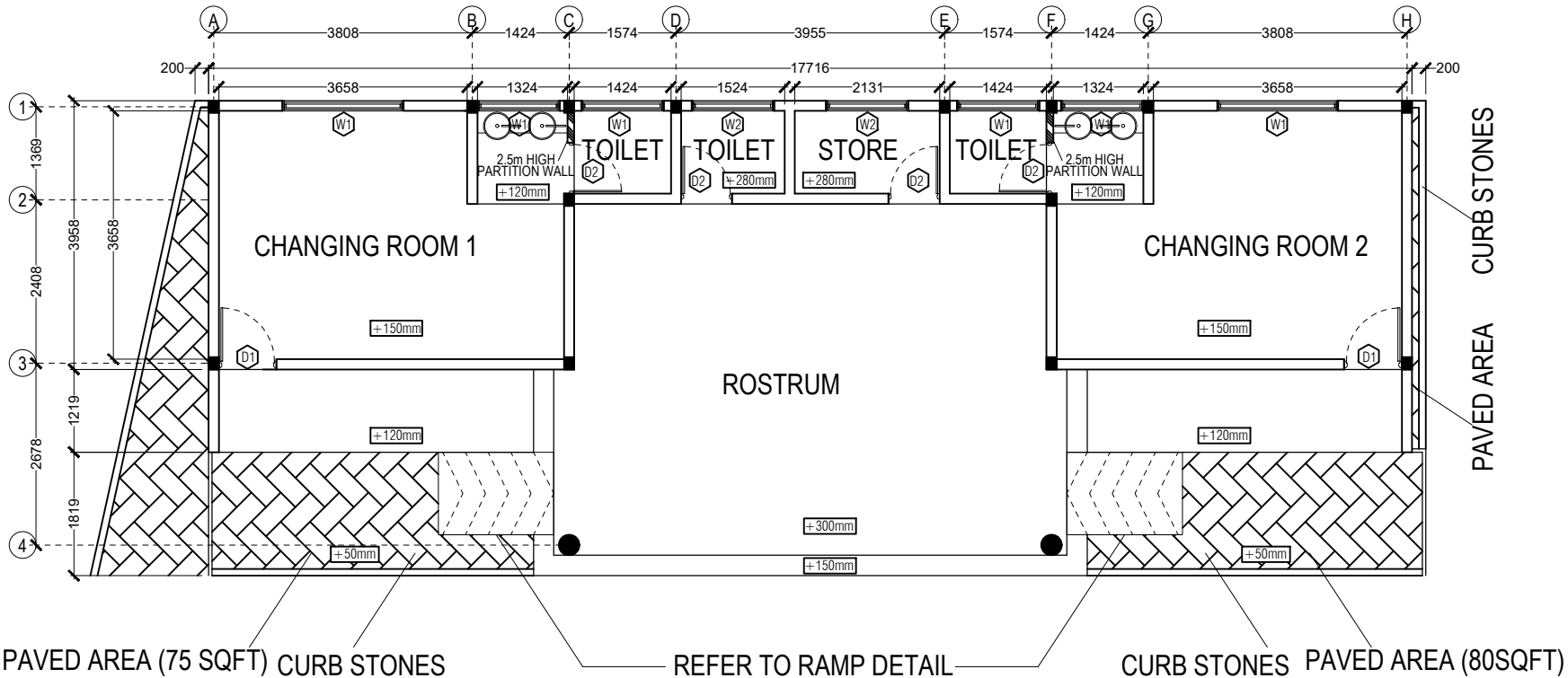

+000mm FLOOR FINISH LEVEL FROM GROUND LEVEL

FLOOR TILING AT BOTH CHANGING ROOMS AND TOILETS
 SINK AREA SHOULD HAVE A FLOOR LEVEL DROP OF MINIMUM OF 30MM
 FULL WALL TILING SHOULD BE DONE AT ALL TOILETS
 FULL TOILET SETS AND DRAINS TO BE FIXED AT ALL TOILETS
 ALL SEWERAGE WASTE PIPES TO BE CONNECTED TO A 2'X2' CATCHPIT

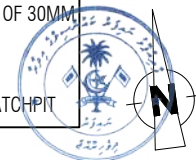

FLOOR PLAN

CHANGING ROOM DETAILS

SCALE 1:100



SECRETARIAT OF THE
FAADHIPOLHU

NAIFARU COUNCIL

PROJECT:

DEVELOPMENT OF A
BASHI COURT
AT LH. NAIFARU

DESIGNED BY:

ISMAIL YAMAAN YOOSUF
ARCHITECT
NAIFARU COUNCIL

CHECKED BY:

ASHHAM MOHAMED
ASSISTANT DIRECTOR
NAIFARU COUNCIL

APPROVED BY:

MOHAMED RASHEED
COUNCIL PRESIDENT
NAIFARU COUNCIL

DATE:

JANUARY 2022

DWG
NO:
03

SHEET
NO:
03

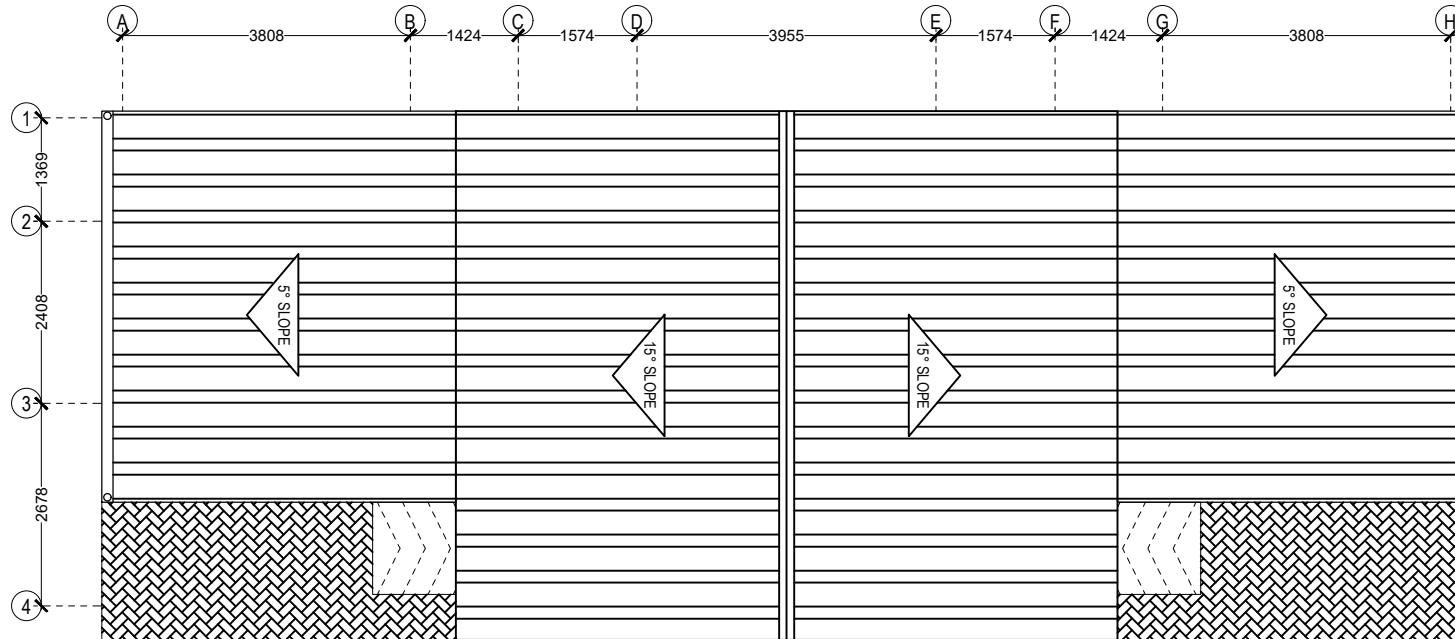

ROOF PLAN

CHANGING ROOM DETAILS

SCALE 1:100





SECRETARIAT OF THE
FAADHIPOLHU

NAIFARU COUNCIL

PROJECT:

DEVELOPMENT OF A
BASHI COURT
AT LH. NAIFARU

DESIGNED BY:

ISMAIL YAMAAN YOOSUF
ARCHITECT
NAIFARU COUNCIL

CHECKED BY:

ASHHAM MOHAMED
ASSISTANT DIRECTOR
NAIFARU COUNCIL

APPROVED BY:

MOHAMED RASHEED
COUNCIL PRESIDENT
NAIFARU COUNCIL

DATE:

JANUARY 2022

DWG
NO:

04

SHEET
NO:

04

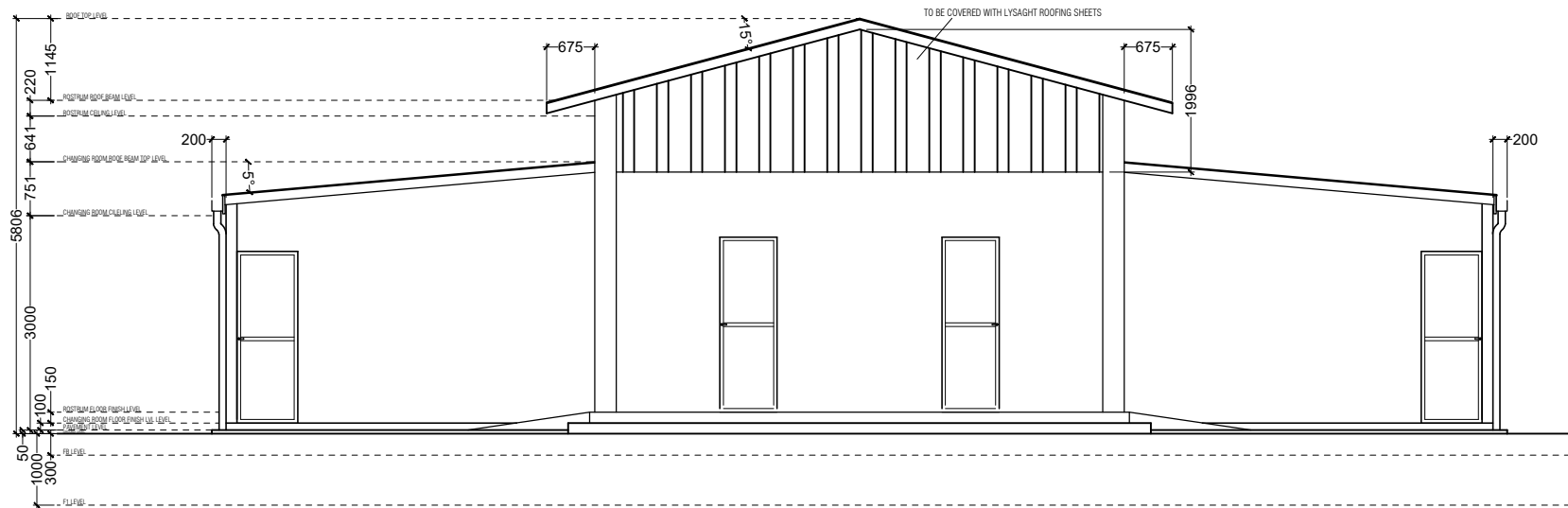

FRONT ELEVATION

CHANGING ROOM DETAILS

SCALE 1:100





SECRETARIAT OF THE
FAADHIPOLHU

NAIFARU COUNCIL

PROJECT:

DEVELOPMENT OF A
BASHI COURT
AT LH. NAIFARU

DESIGNED BY:

ISMAIL YAMAAN YOOSUF
ARCHITECT
NAIFARU COUNCIL

CHECKED BY:

ASHHAM MOHAMED
ASSISTANT DIRECTOR
NAIFARU COUNCIL

APPROVED BY:

MOHAMED RASHEED
COUNCIL PRESIDENT
NAIFARU COUNCIL

DATE:

JANUARY 2022

DWG
NO:
05

SHEET
NO:
05

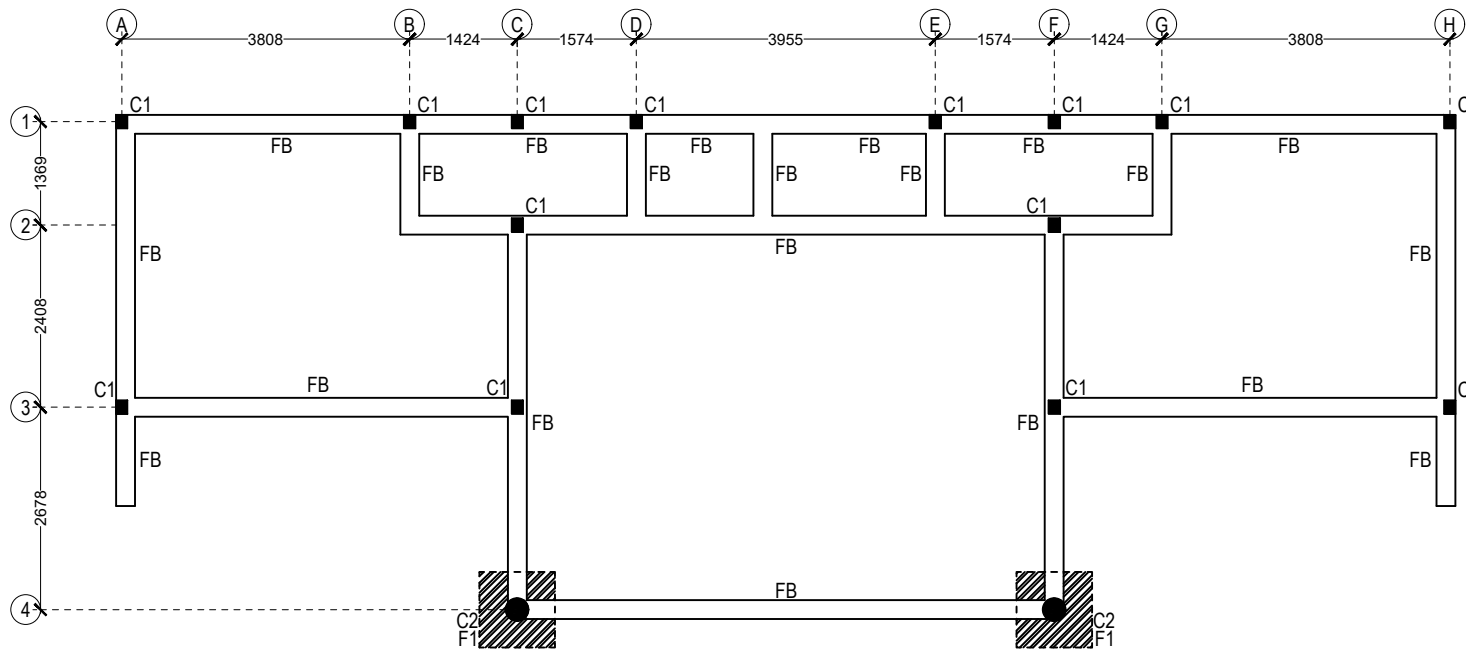

FOUNDATION DEPTH
F1 @ 1000MM BELOW NATURAL GROUND LEVEL
FB @ 300MM BELOW NATURAL GROUND LEVEL

FOUNDATION PLAN

CHANGING ROOM DETAILS

SCALE 1:100





SECRETARIAT OF THE
FAADHIPOLHU

NAIFARU COUNCIL

PROJECT:

DEVELOPMENT OF A
BASHI COURT
AT LH. NAIFARU

DESIGNED BY:

ISMAIL YAMAAN YOOSUF
ARCHITECT
NAIFARU COUNCIL

CHECKED BY:

ASHHAM MOHAMED
ASSISTANT DIRECTOR
NAIFARU COUNCIL

APPROVED BY:

MOHAMED RASHEED
COUNCIL PRESIDENT
NAIFARU COUNCIL

DATE:

JANUARY 2022

DWG
NO:
06

SHEET
NO:
06

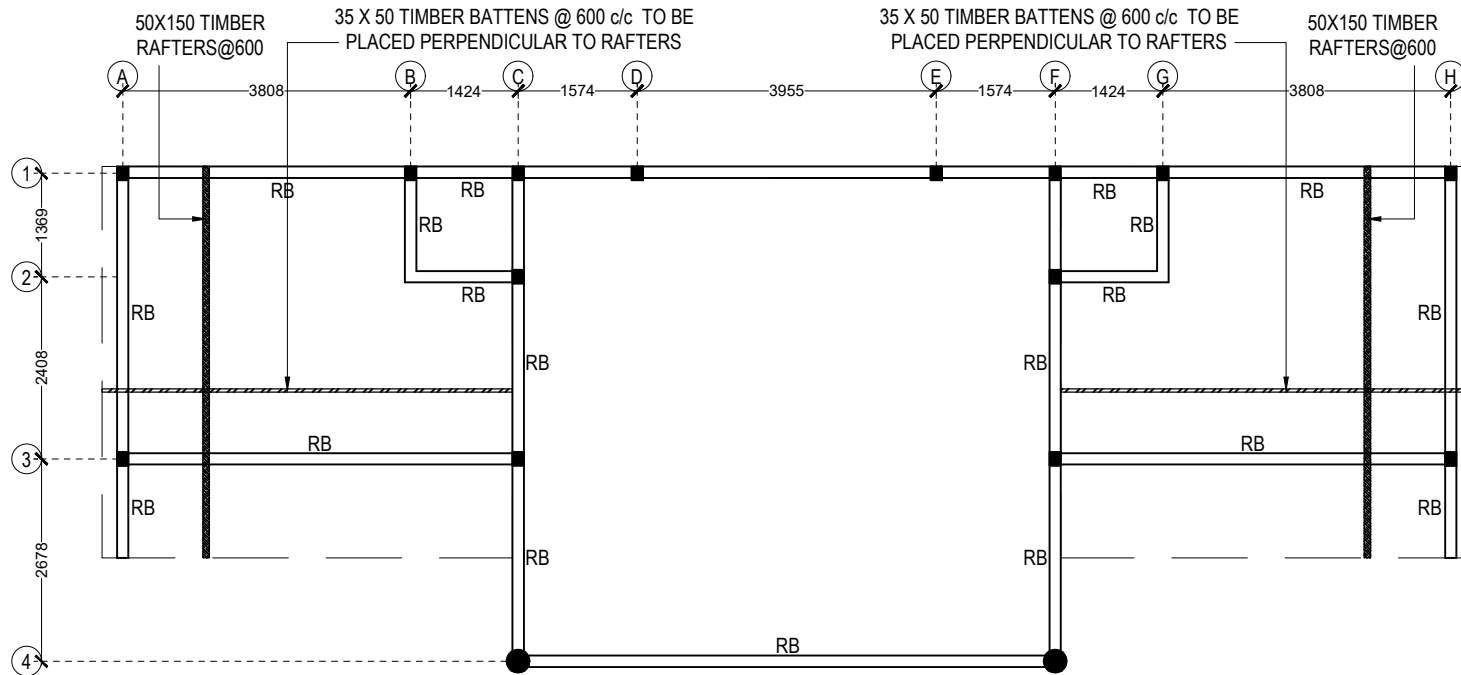

ROOF STRUCTURE PLAN AT CHANGING ROOM ROOF LEVEL

CHANGING ROOM DETAILS

SCALE 1:100





SECRETARIAT OF THE
FAADHIPOLHU

NAIFARU COUNCIL

PROJECT:

DEVELOPMENT OF A
BASHI COURT
AT LH. NAIFARU

DESIGNED BY:

ISMAIL YAMAAN YOOSUF
ARCHITECT
NAIFARU COUNCIL

CHECKED BY:

ASHHAM MOHAMED
ASSISTANT DIRECTOR
NAIFARU COUNCIL

APPROVED BY:

MOHAMED RASHEED
COUNCIL PRESIDENT
NAIFARU COUNCIL

DATE:

JANUARY 2022

DWG
NO:
07

SHEET
NO:
07

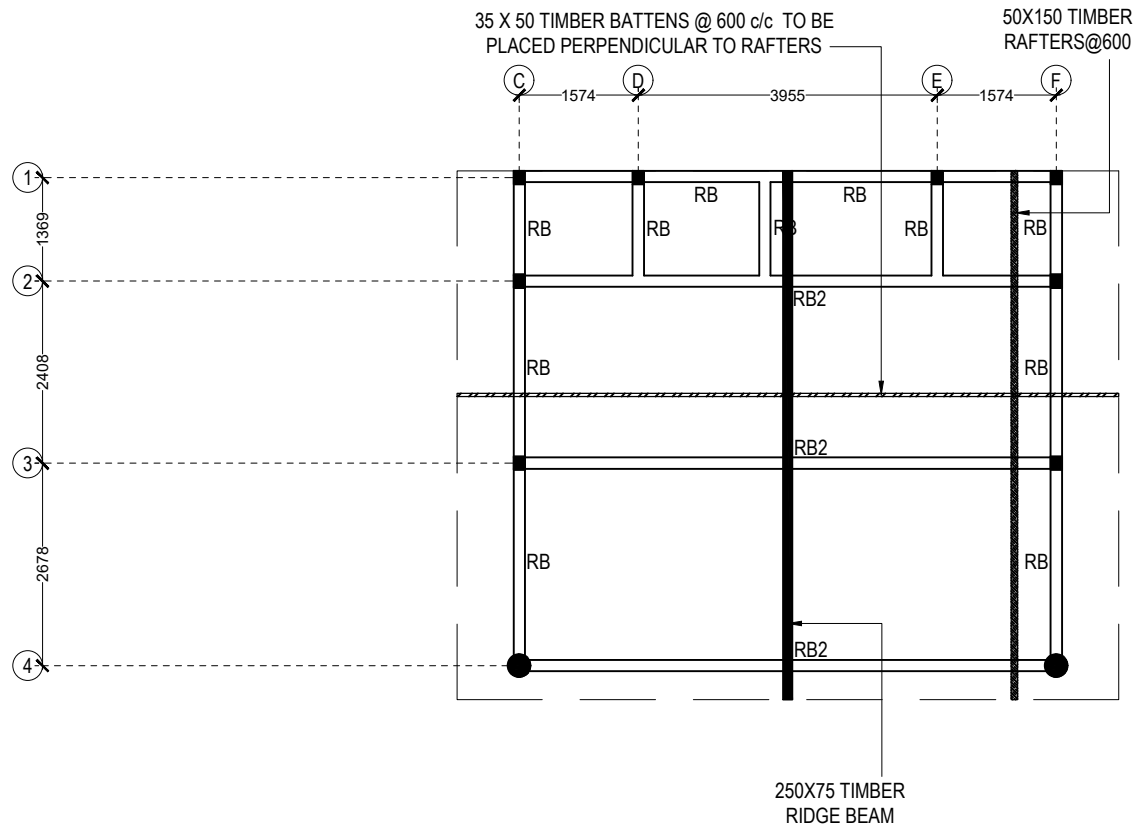

ROOF STRUCTURE PLAN AT ROSTRUM ROOF LEVEL

CHANGING ROOM DETAILS

SCALE 1:100





SECRETARIAT OF THE
FAADHIPOLHU

NAIFARU COUNCIL

PROJECT:

DEVELOPMENT OF A
BASHI COURT
AT LH. NAIFARU

DESIGNED BY:

ISMAIL YAMAAN YOOSUF
ARCHITECT
NAIFARU COUNCIL

CHECKED BY:

ASHHAM MOHAMED
ASSISTANT DIRECTOR
NAIFARU COUNCIL

APPROVED BY:

MOHAMED RASHEED
COUNCIL PRESIDENT
NAIFARU COUNCIL

DATE:

JANUARY 2022

DWG
NO:
08

SHEET
NO:
08

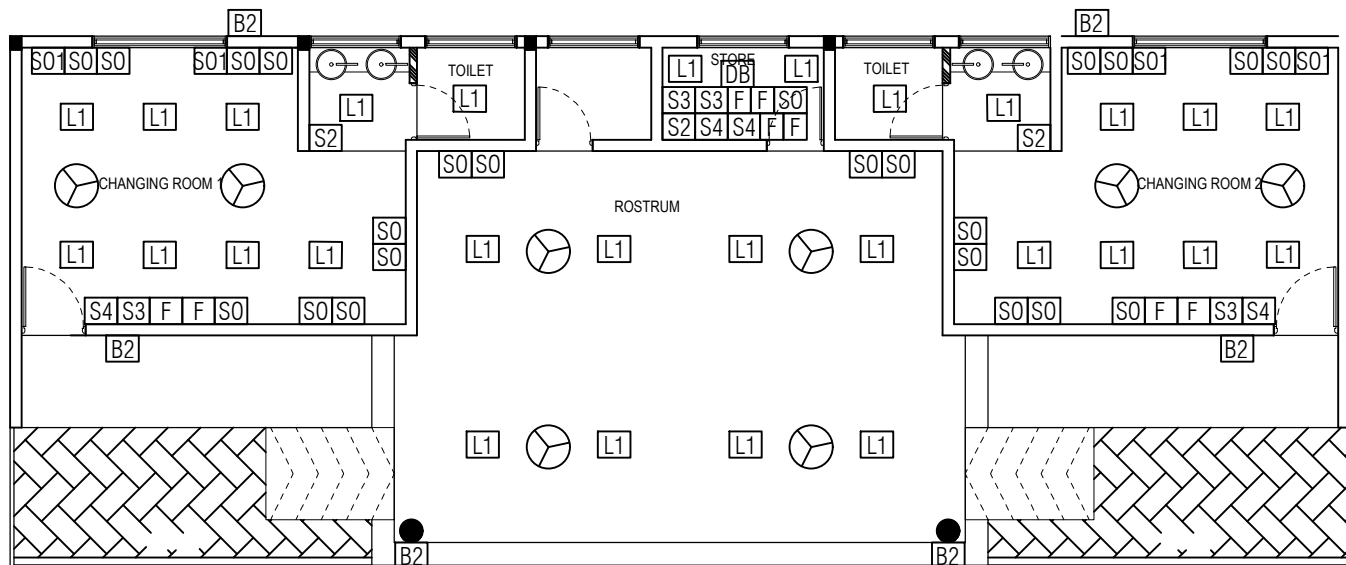

- L1** 18 WATT CEILING MOUNT LED LIGHTS
- B2** 50 WATT WALL MOUNT OUTDOOR LIGHTS @ 9 FEET HEIGHT
- S0** 13A UNIVERSAL SOCKETS @ 4 FEET HEIGHT
- S01** 15A UNIVERSAL SOCKETS @ 7 FEET HEIGHT
- S2** 2 GANG SWITCH @ 4 FEET HEIGHT
- S3** 3 GANG SWITCH @ 4 FEET HEIGHT
- S4** 4 GANG SWITCH @ 4 FEET HEIGHT
- F** FAN CONTROLLER
- DB** D-BOARD @ 5 FEET HEIGHT
-  CEILING FAN

ELECTRICAL LAYOUT PLAN

CHANGING ROOM DETAILS

SCALE 1:100

ROSTRUM LIGHTS, FANS AND EXTERIOR 50W LIGHT SWITCHES TO BE FIXED INSIDE THE STORE





SECRETARIAT OF THE
FAADHIPOLHU

NAIFARU COUNCIL

PROJECT:

DEVELOPMENT OF A
BASHI COURT
AT LH. NAIFARU

DESIGNED BY:

ISMAIL YAMAAN YOOSUF
ARCHITECT
NAIFARU COUNCIL

CHECKED BY:

ASHHAM MOHAMED
ASSISTANT DIRECTOR
NAIFARU COUNCIL

APPROVED BY:

MOHAMED RASHEED
COUNCIL PRESIDENT
NAIFARU COUNCIL

DATE:

JANUARY 2022

DWG
NO:
09

SHEET
NO:
09

SYMBOL	W1	D1	D2
ELEVATION			
FRAME & PANEL	25 Micro Anodized Natural Aluminium Framed Awning Window w/ 6mm thk. frosted glass	25 Micro Anodized Natural Aluminium Framed Door w/ 6mm thk. Fixed FIBRE GLASS Panels	25 Micron Anodized Natural Aluminum Sliding Window with Fixed Glass Panel
QUANTITY	10 Nos	02 Nos	04 Nos

*CHECK ALL MEASUREMENTS ON SITE BEFORE FABRICATION

CHANGING ROOM DETAILS (DOOR WINDOW SCHEDULE)

SCALE 1:50





SECRETARIAT OF THE
FAADHIPOLHU

NAIFARU COUNCIL

PROJECT:

DEVELOPMENT OF A
BASHI COURT
AT LH. NAIFARU

DESIGNED BY:

ISMAIL YAMAAN YOOSUF
ARCHITECT
NAIFARU COUNCIL

CHECKED BY:

ASHHAM MOHAMED
ASSISTANT DIRECTOR
NAIFARU COUNCIL

APPROVED BY:

MOHAMED RASHEED
COUNCIL PRESIDENT
NAIFARU COUNCIL

DATE:

JANUARY 2022

DWG
NO:

10

SHEET
NO:

10

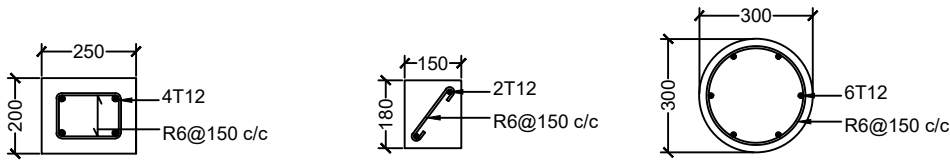

FB

C1

C2

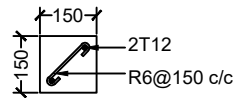

RB

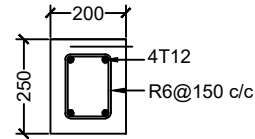

RB2

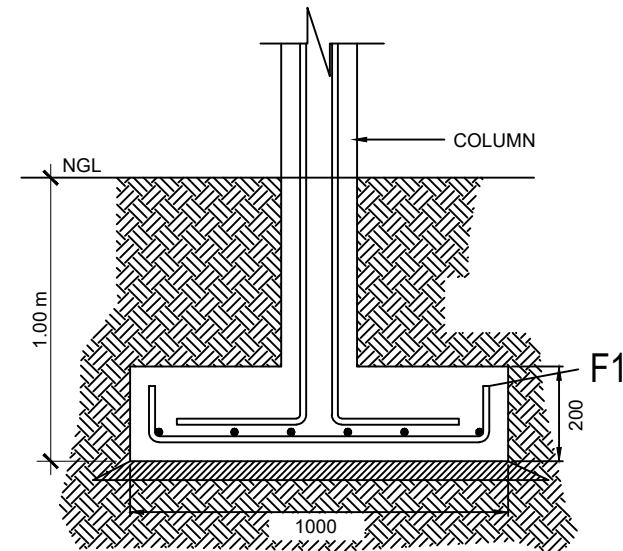
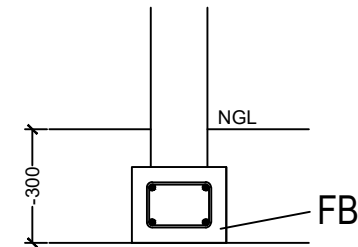

TYPE	DIMENSIONS	REINFORCEMENT
F1	1000mm x 1000mm x 200mm	T16@175C/C B/W (BOTTOM)

FOUNDATION DETAIL

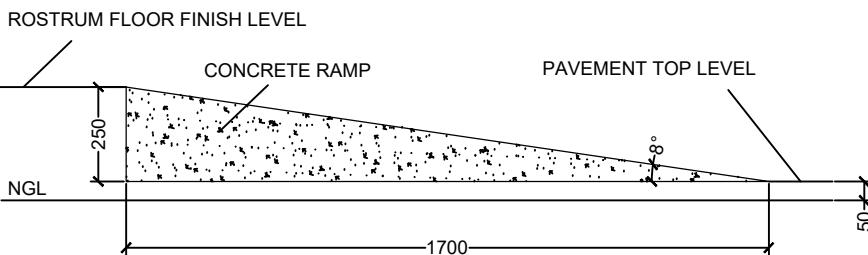

RAMP DETAIL

CHANGING ROOM DETAILS (STRUCTURAL)

SCALE 1:20





SECRETARIAT OF THE
FAADHIPOLHU

NAIFARU COUNCIL

PROJECT:

DEVELOPMENT OF A
BASHI COURT
AT LH. NAIFARU

DESIGNED BY:

ISMAIL YAMAAN YOOSUF
ARCHITECT
NAIFARU COUNCIL

CHECKED BY:

ASHHAM MOHAMED
ASSISTANT DIRECTOR
NAIFARU COUNCIL

APPROVED BY:

MOHAMED RASHEED
COUNCIL PRESIDENT
NAIFARU COUNCIL

DATE:

JANUARY 2022

DWG
NO:

11

SHEET
NO:

11

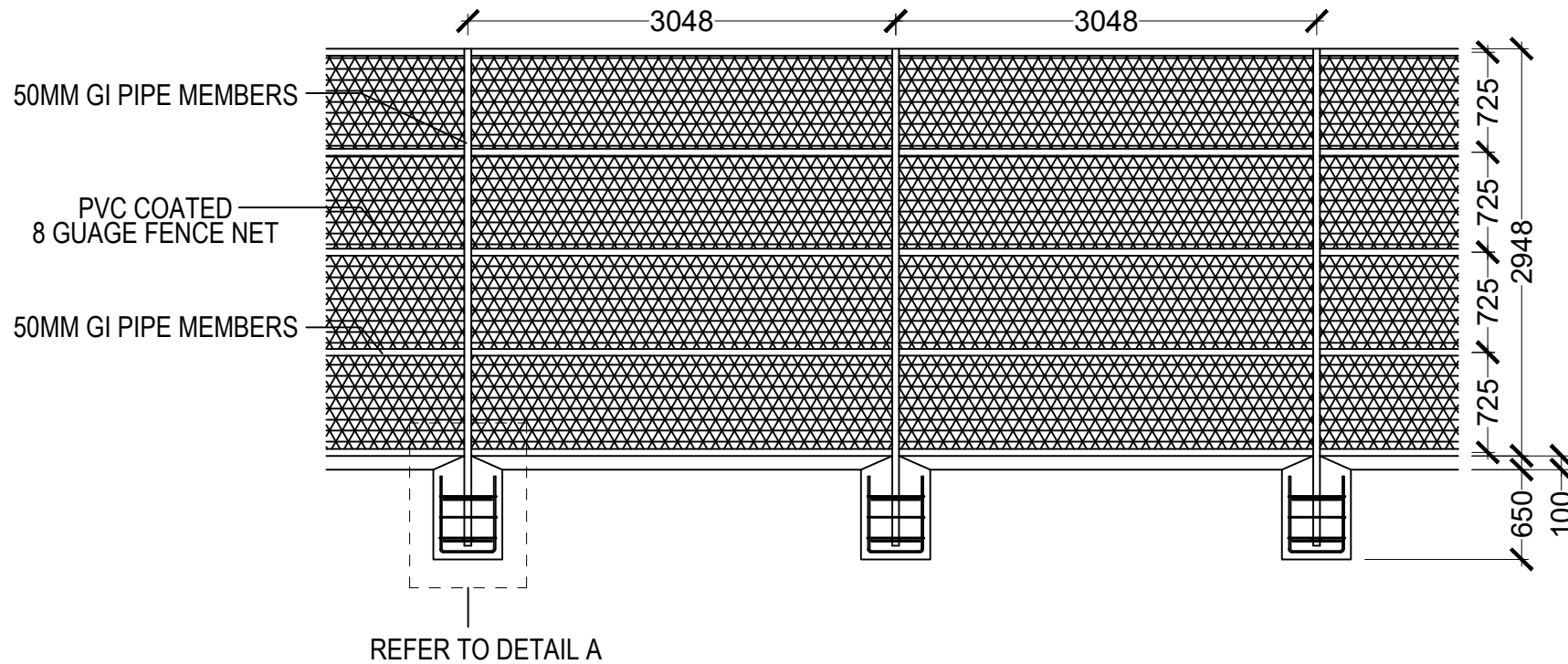

FENCE DETAIL

SCALE 1:100





SECRETARIAT OF THE
FAADHIPOLHU

NAIFARU COUNCIL

PROJECT:

DEVELOPMENT OF A
BASHI COURT
AT LH. NAIFARU

DESIGNED BY:

ISMAIL YAMAAN YOOSUF
ARCHITECT
NAIFARU COUNCIL

CHECKED BY:

ASHHAM MOHAMED
ASSISTANT DIRECTOR
NAIFARU COUNCIL

APPROVED BY:

MOHAMED RASHEED
COUNCIL PRESIDENT
NAIFARU COUNCIL

DATE:

JANUARY 2022

DWG
NO:
12

SHEET
NO:
12

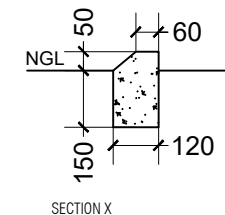
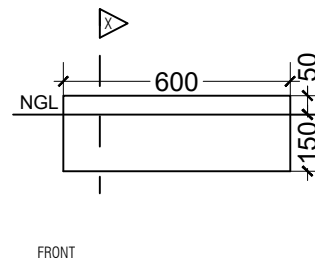

CONCRETE CURB STONE DETAIL

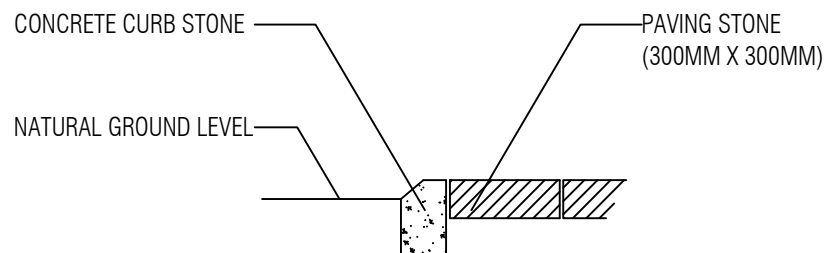

PAVING DETAIL

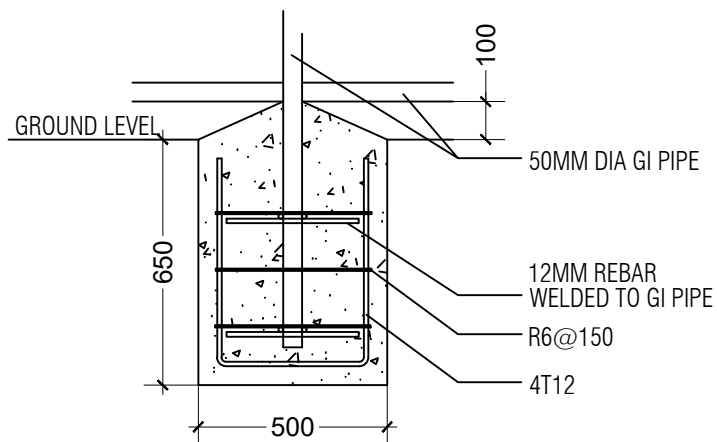

DETAIL A

STRUCTURAL DETAILS

SCALE 1:20





SECRETARIAT OF THE
FAADHIPOLHU

NAIFARU COUNCIL

PROJECT:

DEVELOPMENT OF A
BASHI COURT
AT LH. NAIFARU

DESIGNED BY:

ISMAIL YAMAAN YOOSUF
ARCHITECT
NAIFARU COUNCIL

CHECKED BY:

ASHHAM MOHAMED
ASSISTANT DIRECTOR
NAIFARU COUNCIL

APPROVED BY:

MOHAMED RASHEED
COUNCIL PRESIDENT
NAIFARU COUNCIL

DATE:

JANUARY 2022

DWG
NO:

13

SHEET
NO:

13

50MM GI PIPE MEMBERS

50MM GI PIPE MEMBERS

50MM GI PIPE MEMBERS

50MM GI PIPE MEMBERS

50MM GI PIPE MEMBERS

GROUND LEVEL

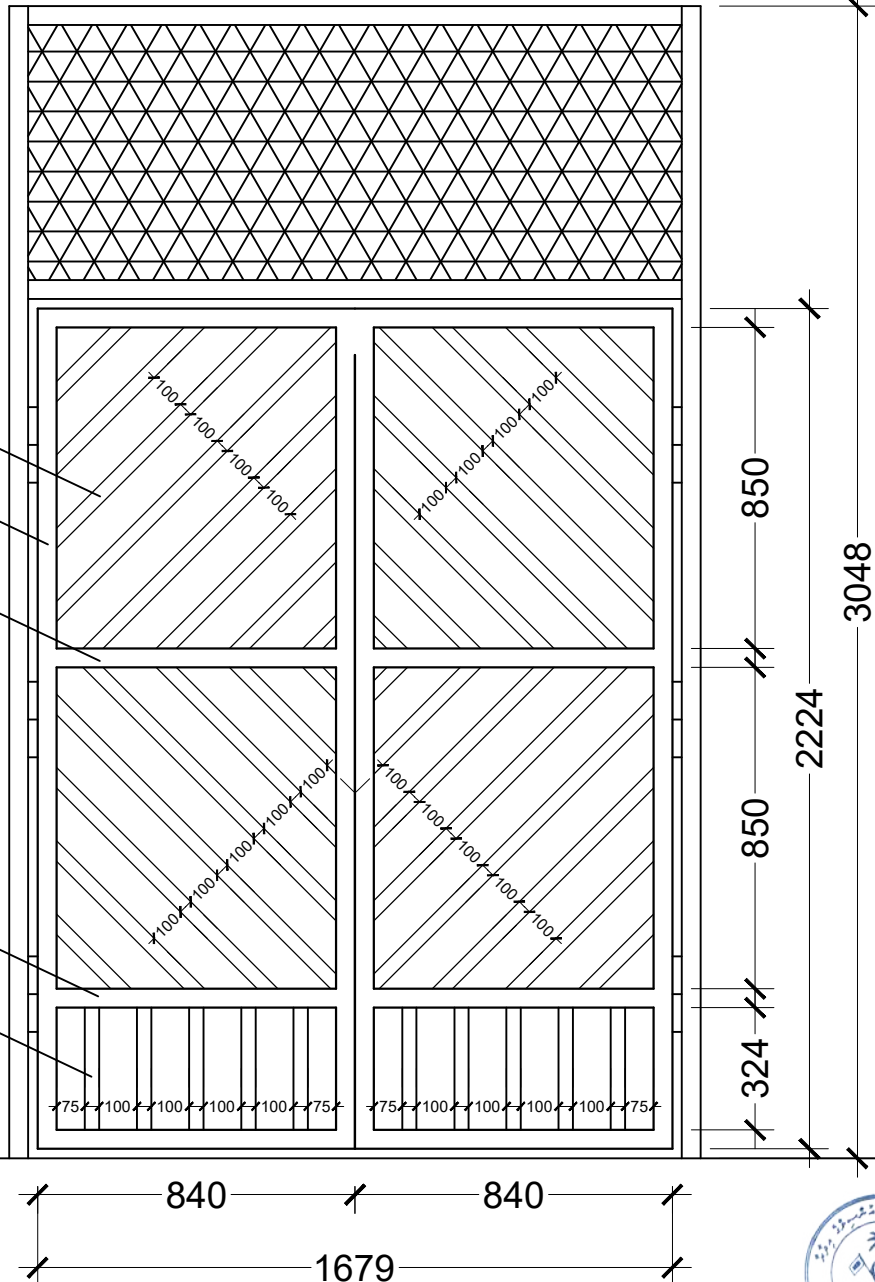

GATE G1

SCALE 1:20





SECRETARIAT OF THE
FAADHIPOLHU

NAIFARU COUNCIL

PROJECT:

DEVELOPMENT OF A
BASHI COURT
AT LH. NAIFARU

DESIGNED BY:

ISMAIL YAMAAN YOOSUF
ARCHITECT
NAIFARU COUNCIL

CHECKED BY:

ASHHAM MOHAMED
ASSISTANT DIRECTOR
NAIFARU COUNCIL

APPROVED BY:

MOHAMED RASHEED
COUNCIL PRESIDENT
NAIFARU COUNCIL

DATE:

JANUARY 2022

DWG
NO:

14

SHEET
NO:

14

1"X2" GI SQUARE HOLLOW

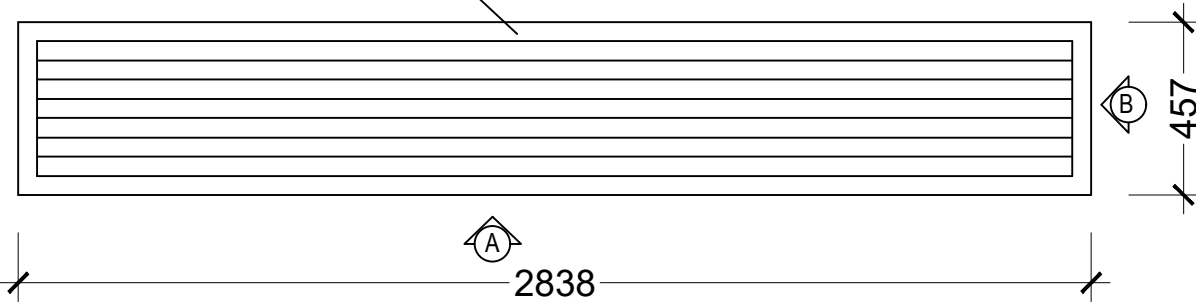

TOP VIEW

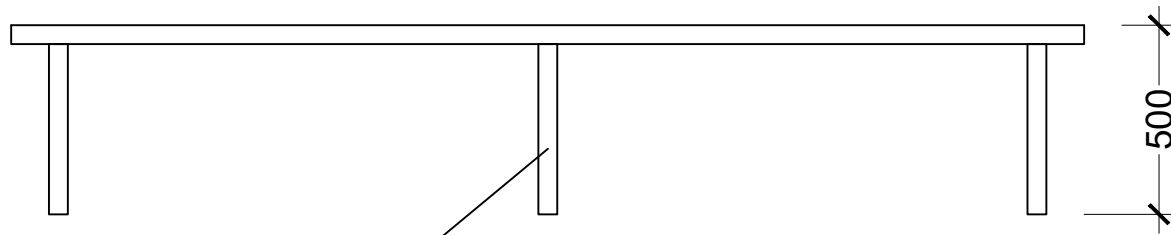

1"X2" GI SQUARE HOLLOW
SIDE VIEW A

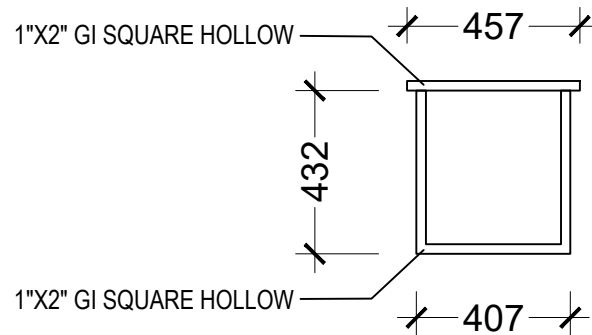

1"X2" GI SQUARE HOLLOW
SIDE VIEW B

BENCH

SCALE 1:20

TOTAL QTY : 4 NOS



2 2020



lhnaifarucouncil



www.naifaru.gov.mv



info@naifaru.gov.mv



6620068



دوره (قرص)	تعداد (تیر)	موضوع	بازگشت	#
		سایه و رنگ و طرح (دوره اول، دوره دوم، دوره سوم، دوره چهارم، دوره پنجم، دوره ششم، دوره هفتم، دوره هشتم، دوره نهم، دوره دهم)	-	
فصل				
		تجزیه و تحلیل و ترکیب مواد (فصل اول، فصل دوم، فصل سوم، فصل چهارم، فصل پنجم، فصل ششم، فصل هفتم، فصل هشتم، فصل نهم، فصل دهم) • نامزدی SHEET NO1 در فصل و جزئیات در SHEET NO 12 , SHEET NO 11 در فصل فصل و جزئیات در فصل و جزئیات.		
		فصل و جزئیات (SHEET NO 12) DETAIL A		
		فصل و جزئیات (فصل اول، فصل دوم، فصل سوم، فصل چهارم، فصل پنجم، فصل ششم، فصل هفتم، فصل هشتم، فصل نهم، فصل دهم)		
		فصل و جزئیات (8 فصل و جزئیات)		
		GATE G1 (SHEET NO 13) نامزدی در فصل و جزئیات		
بخشهای مختلف و جزئیات				
		فصل و جزئیات (F1) (ردیف و جزئیات 1000 در فصل و جزئیات)	2	
		فصل و جزئیات (FB) (ردیف و جزئیات 300 در فصل و جزئیات)		



4 ވަނަ ބައި

މި ސަރުކާރުގެ ބައި ގަތުމަށް

މި ސަރުކާރުގެ ބައި ގަތުމަށް ބޭނުންވާ ފަރާތްތަކުގެ ނަންބަރުތައް ފުރިހަމަކުރުމަށް			
ނަންބަރު	ނަންބަރު ބަލާ ފަރާތް	ފަރާތްތަކުގެ ނަންބަރު ބަލާ ފަރާތް	#
			1
			2
			3
			4
			5
މި ބައި			

މި ސަރުކާރުގެ ބައި ގަތުމަށް ބޭނުންވާ ފަރާތްތަކުގެ ނަންބަރުތައް ފުރިހަމަކުރުމަށް

_____	_____
_____	_____
_____	_____
_____	_____
_____	_____
_____	_____
_____	_____
_____	_____
_____	_____
_____	_____



Form of Tender Security (Bank Guarantee)

The Issuing Bank shall fill in this Bank Guarantee Form in accordance with the instructions indicated.

..... {Bank's Name, and Address of Issuing Branch or Office}

Beneficiary: {Name and Address of Employer}

Date:

TENDER GUARANTEE No.: _____

We have been informed that _____ {name of the Tenderer} (hereinafter called "the Tenderer") has submitted to you its Tender dated _____ (hereinafter called "the Tender") for the execution of _____ {name of contract} under Invitation for Tenders No. _____ ("the IFB").

Furthermore, we understand that, according to your conditions, Tenders must be supported by a Tender guarantee.

At the request of the Tenderer, we _____ {name of Bank} hereby irrevocably undertake to pay you any sum or sums not exceeding in total an amount of _____ [amount in figures] (_____ [amount in words]) upon receipt by us of your first demand in writing accompanied by a written statement stating that the Tenderer is in breach of its obligation(s) under the Tender conditions, because the Tenderer:

(a) has withdrawn its Tender during the period of Tender validity specified by the Tenderer in the Form of Tender; or

(b) having been notified of the acceptance of its Tender by the Employer during the period of Tender validity, (i) fails or refuses to execute the Contract Form, if required, or (ii) fails or refuses to furnish the performance security, in accordance with the ITB.

This guarantee will expire: (a) if the Tenderer is the successful Tenderer, upon our receipt of copies of the contract signed by the Tenderer and the performance security issued to you upon the instruction of the Tenderer; and (b) if the Tenderer is not the successful Tenderer, upon the earlier of (i) our receipt of a copy your notification to the Tenderer of the name of the successful Tenderer; or (ii) {insert date} twenty-eight days after the expiration of the Tenderer's Tender.

Consequently, any demand for payment under this guarantee must be received by us at the office on or before that date.

This guarantee is subject to the Uniform Rules for Demand Guarantees, ICC Publication No. 458

[Signature(s)]



Performance Security

[The issuing bank, as requested by the successful Contractor, shall fill in this form in accordance with the instructions indicated]

Date: [insert date (as day, month, and year)]

Title of the procurement: [Insert general title of the procurement]

Procurement Reference No: [insert reference]

Bank's Branch or Office: [insert complete name of Guarantor]

Beneficiary: [insert complete name of Employer/Procuring Entity]

Performance Guarantee No:

We have been informed that [name of the Contractor], (hereinafter called "the Contractor") has entered into Contract No. [procurement reference number of the Contract]. dated [insert day and month], [insert year], with you, for the execution of [name of contract and brief description of Works] (hereinafter called "the Contract").

Furthermore, we understand that, according to the conditions of the Contract, a performance guarantee is required.

At the request of the Contractor, we [name of the Bank] hereby irrevocably undertake to pay you any sum or sums not exceeding in total an amount of [name of the currency and amount in figures] 1.... (. [amount in words]) such sum being payable in the types and proportions of currencies in which the Contract Price is payable, upon receipt by us of your first demand in writing accompanied by a written statement stating that the Contractor is in breach of its obligation(s) under the Contract, without your needing to prove or to show grounds for your demand or the sum specified therein. This guarantee shall expire, no later than the day of, 2, and any demand for payment under it must be received by us at this office on or before that date. The Guarantor agrees to a one-time extension of this guarantee for a period not to exceed [six months] [one year], in response to the Employer's written request for such extension, such request to be presented to the Guarantor before the expiry of the guarantee.

This guarantee is subject to the Uniform Rules for Demand Guarantees, ICC Publication No. 458, except that subparagraph (ii) of Sub-article 20(a) is hereby excluded.

..... [Seal of Bank and Signature(s)]

Note: -

All italicized text is for guidance on how to prepare this demand guarantee and shall be deleted from the final document.

1 The Guarantor shall insert an amount representing the percentage of the Contract Price specified in the Contract and denominated either in the currency (ies) of the Contract or a freely convertible currency acceptable to the Employer.

2 Insert the date twenty-eight days after the expected completion date. The Employer should note that in the event of an extension of the time for completion of the Contract, the Employer would need to request an extension of this guarantee from the Guarantor. Such request must be in writing and must be made prior to the expiration date established in the guarantee.



مَقْرَرٌ 9

رِزْقٌ وَسَرْمٌ مَقْرَرٌ وَسَرْمٌ وَسَرْمٌ

Advance Payment Security

[The bank, as requested by the successful Contractor, shall fill in this form in accordance with the instructions indicated.]

Date: [insert date (as day, month, and year)]

Title of the Procurement: [Insert general title of the procurement]

Procurement Reference No: [insert reference]

[Issuing bank's letterhead]

Beneficiary: [insert legal name and address of Procuring Entity]

ADVANCE PAYMENT GUARANTEE No.: [insert Advance Payment Guarantee no.]

Advance Payment Guarantee No:

We have been informed that [name of the Contractor] (hereinafter called "the Contractor") has entered into Contract No..... [procurement reference number of the Contract], dated [insert day and month], [insert year] with you, for the execution of [name of contract and brief description of Works] (hereinafter called "the Contract").

Furthermore, we understand that, according to the Conditions of the Contract, an advance payment in the sum [name of the currency and amount in figures] 1 (..... [amount in words]) is to be made against an advance payment guarantee.

At the request of the Contractor, we [name of the Bank]. hereby irrevocably undertake to pay you any sum or sums not exceeding in total an amount of [name of the currency and amount in figures] * (..... [amount in words]) upon receipt by us of your first demand in writing accompanied by a written statement stating that the Contractor is in breach of its obligation under the Contract because the Contractor used the advance payment for purposes other than the costs of mobilization in respect of the Works.

It is a condition for any claim and payment under this guarantee to be made that the advance payment referred to above must have been received by the Contractor on its account number [Contractor's account number]. at [name and address of the Contractor's Bank].

The maximum amount of this guarantee shall be progressively reduced by the amount of the advance payment repaid by the Contractor as indicated in copies of interim statements or payment certificates which shall be presented to us. This guarantee shall expire, at the latest, upon our receipt of a copy of the interim payment certificate indicating that eighty (80) percent of the Contract Price has been certified for payment, or on the day of 2, whichever is earlier. Consequently, any demand for payment under this guarantee must be received by us at this office on or before that date. The Guarantor agrees to a one-time extension of this guarantee for a period not to exceed [six months] [one year], in response to the Employer's written request for such extension, such request to be presented to the Guarantor before the expiry of the guarantee. This guarantee is subject to the Uniform Rules for Demand Guarantees, ICC Publication No. 458.

..... [Seal of Bank and Signature(s)]

Note:

All italicized text is for guidance in preparing this demand guarantee and shall be deleted from the final document.

1 The Guarantor shall insert an amount representing the amount of the advance payment denominated either in the currency(ies) of the advance payment as specified in the Contract, or in a freely convertible currency acceptable to the Employer.

2 Insert the expected expiration date of the Time for Completion. The Employer should note that in the event of an extension of the time for completion of the Contract, the Employer would need to request an extension of this guarantee from the Guarantor. Such request must be in writing and must be made prior to the expiration date established in the guarantee.





lhnaifarucouncil



www.naifaru.gov.mv



info@naifaru.gov.mv



6620068