



INFORMATION SHEET FOR PROCUREMENT OF CAT PUMP REQUIRED FOR RO PLANT

Reference No.: FNK-I/IUL/2023/180

Issued on: 18th May 2023

Issued by:

Fenaka Corporation Limited

Male', Republic of Maldives

Section I: Instruction to Bidders

A. General	
1. Scope of Bid	1.1 Fenaka Corporation Limited requests quotations for Cat pump required for RO Plant in accordance with <i>Section III, Technical Specifications</i>
2. Eligible Participants	2.1 Local companies registered in Maldives are eligible to participate in the tender
	2.2 Foreign companies are eligible to participate in the tender only if the total bid value is above 2,500,000 Maldivian Rufiyaa.
B. Preparation of the Bid	
3. Bid Prices	3.1 The unit price of each item and the total price shall be clearly indicated in the quotation
	3.2 All items shall be quoted in the bid (please refer to <i>Section III, Technical Specifications</i> for the details of required items)
	3.3 Quotation shall separately indicate the additional charges such as freight charges and insurance. GST for mentioned charges should be omitted in grand total.
	3.4 The bidder shall submit quotation on CIF basis to Male' port
4. Currency	4.1 The bidder shall quote entirely in Maldivian Rufiyaa
5. Alternative Bids	5.1 Bidders can submit a maximum of two (2) options
6. Validity of Bids	6.1 Quotation shall remain valid for minimum sixty (60) days from the date of bid opening
7. Bid Security	7.1 All bids should be accompanied with a bid security of USD 1,000 (One Thousand US Dollars) or its equivalent in Maldivian Rufiyaa
	7.2 The bid security should be: <ul style="list-style-type: none"> - Original bank guarantee letter (or) - Bank guaranteed and stamped check (or) - An insurance policy from Maldives Monetary Authority (MMA) registered insurance company
	7.3 Any bid not accompanied by a Bid Security shall be rejected during bid opening

	7.4 The bid security must be valid for a minimum of twenty (20) additional days beyond the validity of quotation
8. Technical Compliance	<p>8.1 All relevant information including the brand shall be given to enable technical evaluation of quoted items</p> <p>8.2 If the manufacturer or assembler is not the same as the bidder, a document indicating that manufacturer or assembler is willing to sell the item to the bidder is required</p> <p>8.3 Manufacturer's Authorization letter will be required to enable technical evaluation</p> <p>8.4 If the goods do not comply with the requirements mentioned in <i>Section III, Technical Specifications</i>, the bid will be rejected during evaluation.</p>
9. Documents Comprising the Bid	<p>9.1 Quotation (inclusive of the delivery period and payment terms)</p> <p>9.2 Specifications of the offered product</p> <p>9.3 Details of the company</p> <ul style="list-style-type: none"> - Company profile/background - Company registration certificate - GST registration certificate (for local bidders only) - TAX clearance report (6 months validity) - Contact details (name, designation, mobile number and e-mail address) <p>9.4 Experience letters, if available</p> <ul style="list-style-type: none"> - Letters within past five (5) years - Relevant experience letters - Letters with project name and value <p>9.5 One (1) compact disc with original bid document scanned and written</p> <p>9.6 Bids lacking the documents above are subjected to be rejected during the bid opening</p>
10. Format of Bid	<p>10.1 The Bidder shall submit two (2) sets of the bid document (1 original and 1 copy), enclosed separately in two envelopes, and sealed with company stamp</p> <p>10.2 All pages of the bid document shall be stamped and bound properly (excluding the bid security)</p>
C. Bid Submission	

11. Sealing and Marking Bid Document	11.1 The bid document shall be sealed properly in an envelope clearly marked ‘ORIGINAL’ or ‘COPY’, with the name of the company and the tender reference number (FNK-I/IUL/2023/180)
12. Bid Opening	12.1 The bids will be opened on 28 th May 2023, 1300hrs in the presence of bidders 12.2 Bids will be opened at: Fenaka Corporation Limited Hilaalee Magu, K. Male’, Republic of Maldives 12.3 Bids received electronically will not be accepted
13. Bid Rejection	13.1 Bidders that arrive after bid submission deadline shall not be able to participate in the bid 13.2 Bidders that do not register for the tender are unable to participate in the bid opening 13.3 Bids lacking the documents mentioned in 9. <i>Documents Comprising the Bid</i> (except 9.4 <i>Experience letters</i>) and that do not comply with 10. <i>Format of Bid</i> are subjected to be rejected
D. Awarding of Contract	
14. Payment Terms	14.1 An advance payment will not be released for this project 14.2 Proposed payment terms should not be tied with submission of Bill of Lading.
15. Packing	14.1 Materials must be packed in accordance with the packing list given in <i>Section III: Technical Specifications/Packing List</i> to avoid rejection

Section II: Evaluation Criteria

Proposal Cost: 70 points for the lowest price

- $(\text{Lowest price} / \text{proposed price}) \times 70$

Delivery: 20 points for the lowest delivery period

- $(\text{Lowest delivery period} / \text{proposed delivery period}) \times 20$
- If the delivery period indicates 'ex-stock', it shall be taken same as the party offering the longest delivery period.

Credit Period: 10 points for the maximum credit period

- $(\text{Proposed credit period} / \text{longest credit period}) \times 10$

Note: Any discrepancy in technical details specified in quotation with technical specification document, the specification shall prevail.

Section III: Technical Specifications

Description	Quantity
Cat Pump 3541	01

ITEM SPECIFICATION

BRANCH: HA. Dhidhoo

BRAND	CAT PUMPS
MODEL NO.	3541
HEAD MATERIAL	STAINLESS STEEL
CRANKCASE CAPACITY	4 L
PULLEY MOUNTING	EITHER SIDE

Note: Specification for cat pump 3541 attached below.

DATA SHEET

35 FRAME PLUNGER PUMPS



Forged Brass	Stainless Steel	Stainless Steel Flushed	Nickel Aluminum Bronze
3545	3541D	3541C	3547



Model 3545 Shown
(Shaft protector included, mounting rails sold separately)

FEATURES

- Triplex design delivers high efficiency and low pulsation.
- Durable dual V-Packings are lubricated and cooled by pumped liquid.
- Pre-set Lo-Pressure Seals provide secondary protection against external leaks and require no packing adjustments.
- Special flushed inlet manifold on model 3541C permits external flush for added cooling with high temperature liquids and lubrication with low lubricity liquids.
- Standard NBR seals with alternative options for temperature and chemical compatibility.

SPECIFICATIONS	U.S. Measure	Metric Measure
Flow	45 gpm	170 lpm
Pressure Range	100 – 1000 psi	6.9 – 69 bar
Pump RPM*	765 rpm	765 rpm
Inlet Pressure Range	Flooded – 70 psi	Flooded – 4.8 bar
Max. Liquid Temp. (NBR)	140° F	60° C
Alternative seals available for high temp up to 200° F		
Bore	1.772"	45 mm
Stroke	1.890"	48 mm
Crankcase Capacity	4.2 Qts.	4 l
Inlet Ports (2)	1 ½" NPT(F)	1 ½" NPT(F)
Flush Ports (2) (C - only)	¼" NPT(F)	¼" NPT(F)
Discharge Ports (2)	1" NPT(F)	1" NPT(F)
Shaft Diameter	1.378"	35 mm
Pulley Mounting	Either Side	Either Side
Weight	139 lbs.	63 kg
Dimensions (3545)	23.86 x 18.11 x 9.72"	606 x 460 x 247 mm
Dimensions (3541D, 3541C, 3547)	24.33 x 18.11 x 9.72"	618 x 460 x 247 mm

*Pump minimum is 100 RPM.

ALTERNATIVE SEAL CONFIGURATION

MATERIAL	SUFFIX CODE	MAXIMUM TEMPERATURE	
NBR	—	140° F	(60° C)
FPM	.0110	180° F	(82° C)
EPDM	.0220	160° F	(71° C)
IPFE (3545)	.0770	200° F	(93° C)
IPFE (3541D, 3541C, 3547)	.0770	180° F	(82° C)
STHT (3545)	.3400	190° F	(88° C)
STHT (3541D, 3541C, 3547)	.3400	180° F	(82° C)

See Tech Bulletin 99TCH002 for inlet conditions and RPM at high temperature.

DETERMINING THE PUMP R.P.M.	Rated gpm	=	"Desired" gpm
	Rated rpm	=	"Desired" rpm
DETERMINING THE REQUIRED H.P.	HP (Electric Brake)	=	$\frac{\text{gpm} \times \text{psi}}{1460}$
DETERMINING MOTOR PULLEY SIZE	Motor Pulley O.D.	=	$\frac{\text{Pump Pulley O.D.} \times \text{Pump rpm}}{\text{Motor rpm}}$

Refer to pump Service Manual for repair procedure and additional technical information.

PARTS LIST

ITEM	PART NUMBER	MATL	PART NUMBER	MATL	PART NUMBER	MATL	DESCRIPTION	QTY
	3545		3541C		3547			
5	96049	S	96049	S	96049	S	Screw, HH Sems (M10x25) (See Tech Bulletin 074, 125) [06/18]	8
8	134604	ALE	134604	ALE	134604	ALE	Cover, Bearing (See Tech Bulletin 118, 125) [06/18]	2
9	815279	FBR	815279	FBR	815279	FBR	Shim, Split 2-PC (See Tech Bulletin 125) [06/18]	2
10	12398	NBR	12398	NBR	12398	NBR	O-Ring, Bearing Cover – 70D	2
11	13296	NBR	13296	NBR	13296	NBR	Seal, Oil, Crankshaft	2
15	29326	STL	29326	STL	29326	STL	Bearing, Roller	2
20	121467	TNM	121467	TNM	121467	TNM	Rod, Connecting Assembly (Includes: 21, 22, 23) (See Tech Bulletin 074) [10/00]	3
21	126749	STCP R	126749	STCP R	126749	STCP R	Washer, Locking (M10)	6
22	126593	STCP R	126593	STCP R	126593	STCP R	Washer, Flat (M10)	6
23	122045	STZP	122045	STZP	122045	STZP	Screw, HH (M10 x 55)	6
25	29325	FCM	29325	FCM	29325	FCM	Crankshaft, Dual End	1
31	828710	PE	828710	PE	828710	PE	Protector, Cap w/Foam Gasket	1
32	43211	ABS	43211	ABS	43211	ABS	Cap, Oil Filler	1
33	14177	NBR	14177	NBR	14177	NBR	O-Ring, Oil Filler Cap – 70D	1
34	126743	STCP R	126743	STCP R	126743	STCP R	Bolt, Eye (M12 x 1.75) (For Lifting Pump Only)	1
37	92241	PC	92241	PC	92241	PC	Gauge, Oil, Bubble w/Gasket (See Tech Bulletin 074)	1
38	44428	NBR	44428	NBR	44428	NBR	Gasket, Flat, Oil Gauge – 80D	1
40	125753	S	125753	S	125753	S	Screw, HH Sems (M8 x 25) (See Tech Bulletin 074)	8
48	25625	STCP	25625	STCP	25625	STCP	Plug, Drain (1/2" x 19 BSP)	1
49	23170	NBR	23170	NBR	23170	NBR	O-Ring, Drain Plug – 70D	1
50	45936	ALE	45936	ALE	45936	ALE	Cover, Rear (See Tech Bulletin 118)	1
51	16612	NBR	16612	NBR	16612	NBR	O-Ring, Crankcase Cover – 70D	1
53	134784	ALE	134784	ALE	134784	ALE	Crankcase Assembly (Includes: 34, 54) (See Tech Bulletin 118, 125, 127) [06/18]	1
54	27488	S	27488	S	27488	S	Pin, Guide	2
56	27790	POP	27790	POP	27790	POP	Pan, Oil	1
59	92538	S	92538	S	92538	S	Screw, HHC Sems (M6 x 16)	2
64	43864	CM	43864	CM	43864	CM	Pin, Crosshead	3
65	† 45116	SSZZ	45116	SSZZ	45116	SSZZ	Rod, Plunger	3
69	126587	STCP R	126587	STCP R	126587	STCP R	Washer, Oil Seal	3
70	100488	NBRS	100488	NBRS	100488	NBRS	Seal, Oil, Crankcase	3
75	43865	S	43865	S	43865	S	Slinger, Barrier	3
88	45676	S	45676	S	45676	S	Washer, Keyhole (M16)	3
90	46806	CC	46806	CC	46806	CC	Plunger (M45 x 145)	3
95	† 89778	SS	89778	SS	89778	SS	Stud, Plunger Retainer (M10 x 135)	3
96	20189	PTFE	20189	PTFE	20189	PTFE	Back-up Ring, Plunger Retainer	3
97	11345	NBR	11345	NBR	11345	NBR	O-Ring, Plunger Retainer – 70D	3
98	44085	SS	44085	SS	44085	SS	Gasket, Retainer	3
99	† 44084	SS	44084	SS	44084	SS	Retainer, Plunger (M10) (See Tech Bulletin 074)	3
100	44119	PPG	44119	PPG	44119	PPG	Retainer, Seal (See Tech Bulletin 105)	3
106	46809	NBR	—	—	—	—	Seal, LPS w/S-Spg	3
—	—	—	48384	NBR	48384	NBR	Seal, LPS w/SS-Spg	3
107	46811	BB	48380	D	48380	D	Spacer, LPS	3
110	49482	BBCP R	48375	SS	49994	NAB	Manifold, Inlet	1
—	—	—	49304	SS	—	—	Manifold, Inlet, Flushed (1/2" Flush Port)	1
112	18688	NBR	18688	NBR	18688	NBR	O-Ring, Inlet Manifold – 70D	3
117	44585	S	44585	S	44585	S	Screw, HSH (M14 x 40) (See Tech Bulletin 074)	4
126	46812	BB	48383	D	48383	D	Adapter, Female	3
127	46813	STGS	46813	STGS	46813	STGS	V-Packing	6
128	46814	BB	48386	SS	49319	NAB	Adapter, Male	3
141	49483	SS	49483	SS	49483	SS	Spring, Coil, Large (See Tech Bulletin 107)	3
155	17784	NBR	17784	NBR	17784	NBR	O-Ring, V-Packing Spacer – 80D	3
157	49484	BB	49506	SS	49507	NAB	Spacer, V-Packing (See Tech Bulletin 107)	3
159	17784	NBR	17784	NBR	17784	NBR	O-Ring, V-Packing Spacer – 80D	3
163	26143	NBR	26143	NBR	26143	NBR	O-Ring, Seat – 80D	6
164	46822	S	48393	SS	48393	SS	Seat	6
166	43932	S	44108	SS	44108	SS	Valve	6
167	44109	SS	44109	SS	44109	SS	Spring, Valve	6
168	44728	PVDF	44728	PVDF	44728	PVDF	Retainer, Spring	6
170	44729	SS	44729	SS	44729	SS	Washer, Spring Retainer	6
171	44644	SS	44644	SS	44644	SS	Coil Spring (70kg), Valve Plug	6
172	89827	NBR	89827	NBR	89827	NBR	O-Ring, Valve Plug – 90D	6
173	48364	D	48364	D	48364	D	Back-up Ring, Valve Plug	6
174	46444	FBB	49300	SSD	46463	NAB	Plug, Valve (See Tech Bulletin 074)	6
185	49486	BBCP R	49302	SSD	49309	NAB	Manifold, Discharge (See Tech Bulletin 127 – 3541C, 3541D)	1
188	89981	S	89981	S	89981	S	Screw, HSH (M12 x 70) (See Tech Bulletin 074)	8
250	855042	NY	855042	NY	855042	NY	Protector, Shaft w/2 Screws, Lockwashers and Washers	1

† Production parts are different than repair parts. R Components comply with RoHS Directive. * Review individual parts in each kit for material code identification.

For additional technical information see www.catpumps.com/literature/tech-bulletins. MATERIAL CODES (Not Part of Part Number)
 ABS=ABS Plastic ALE=Aluminum Epoxy BB=Brass BBCP=Brass/Chrome Plated CC=Ceramic CM=Chrome-Moly D=Acetal EPDM=Ethylene Propylene Diene Monomer F=Cast Iron
 FBB=Forged Brass FBR=Fiber FCM=Forged Chrome-moly FPM=Fluorocarbon NAB=Nitride Aluminum Bronze NBR=Medium Nitrile (Buna-N) NBRS=Buna, Silicone Free NY=Nylon
 PC=Polycarbonate PE=Polyethylene PPG=Glass Filled Polypropylene PTFE=Pure Poly tetrafluoroethylene PVDF=Polyvinylidene Fluoride S=304SS SS=316SS SF TB=Special Blend PTFE Black
 SSZZ=316SS/Zamak STGS=Special Blend PTFE White Silicon Free STCP=Steel/Chrome Plated STL=Steel STZP=Steel/Zinc Plated TNM=Special High Strength

Standard and optional Seal Kits and Valve Kits listed on pages 3 and 4. Optional Parts and Accessories and Service parts listed on Page 3.

EXPLODED VIEW

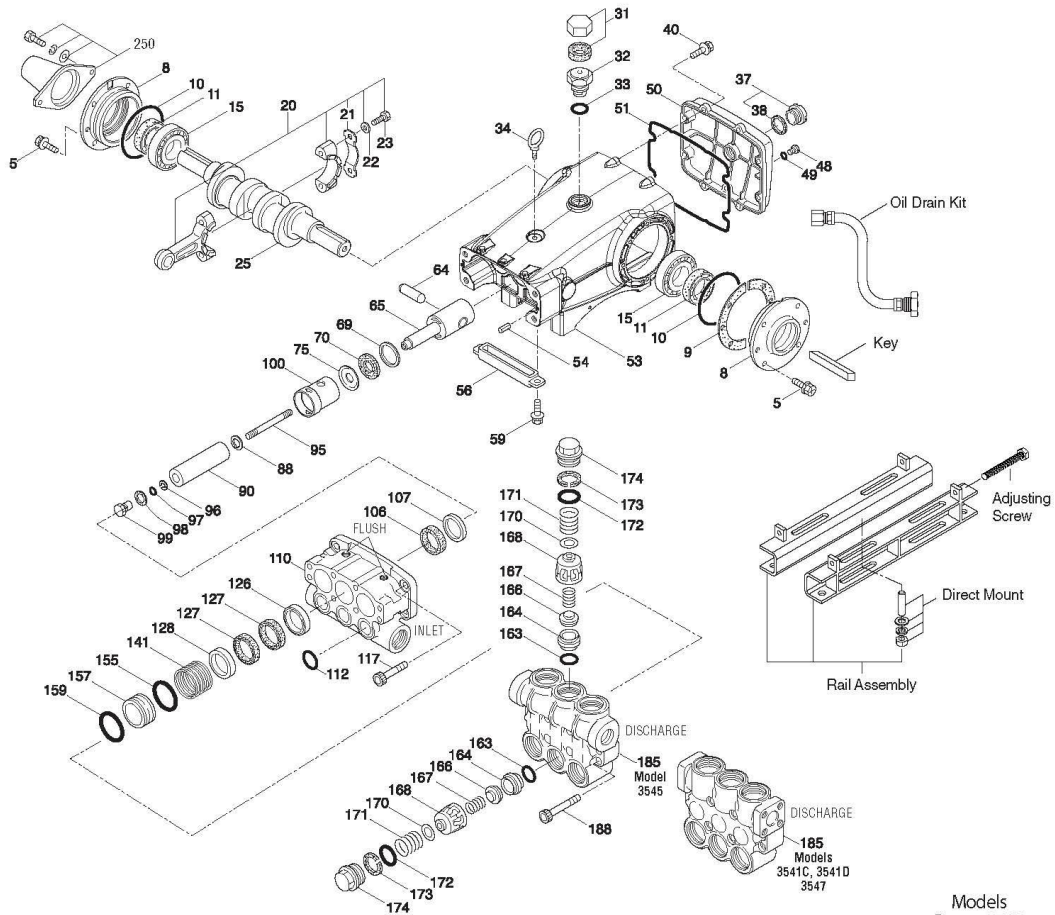

Models
Brass - 3545
Stainless Steel - 3541D
SS Flushed - 3541C
NAB - 3547
May 2020

OPTIONAL PARTS AND ACCESSORIES

PART	DESCRIPTION	QTY
34021	Key, M10 x 8 x 70	1
92674	Mount, Rail Assembly	1
34018	Mount, Direct (STZP R) (See Tech Bulletin 074)	1
34039	Mount, Direct (S) (See Tech Bulletin 074)	1
990013	Hub, "B", 35 mm (STL)	1
80540	Screwing, Adjusting M12 x 100	2
34314	Kit, Oil Drain	1
30696	Plier, Reverse	1

SERVICE PARTS

PART	DESCRIPTION	QTY
33234	Kit, Seal (3545) - Standard	1
33834	Kit, Seal (3541D, 3541C, 3547) - Standard	1
33235	Kit, Valve (3545) - Standard	2
33835	Kit, Valve (3541D, 3541C, 3547) - Standard	2
6100	Oil, Case (12 - 21 oz. bottle)	1
6119	Lubricant, Anti-Seize (2 oz) (3541D, 3541C)	1
6124	Gasket, Liquid (3 oz)	1
818428	Head, Complete - 3545 w/NBR Seals and O-Rings	1
818371	Head, Complete - 3541D w/NBR Seals and O-Rings	1
818575	Head, Complete - 3547 w/NBR Seals and O-Rings	1
819000	Assy, Crankcase, Cast Iron Conversion	1

Kits - FPM (.0110), EPDM (.0220), IPPE (.0770), STHT (.3400) listed on Page 4.

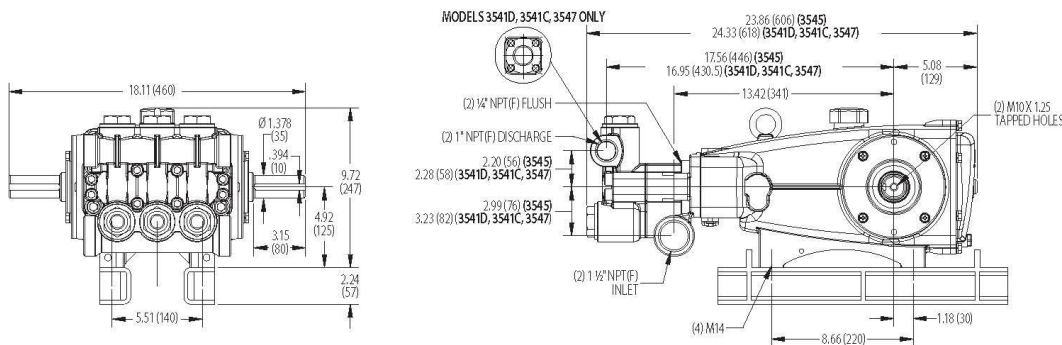

Base Model 3545

SEAL KITS One (1) seal kit required per pump

PUMP MODELS	NBR (STD)	FPM (.0110)	EPDM (.0220)◆	STHT (.3400)	IPFE (.0770)
3545	33234 *	31261	33223 *	76209	76615
3541D, 3541C, 3547	33834 *	31261	33223 *	76209	76615

ITEM (Included in Seal Kits)						DESCRIPTION	QTY
97	11345	11375	701490	11345	702961	O-Ring, Plunger Retainer	3
106	46809	702013	46945	702013	703296	Seal, LPSw/SS-Spg	3
112	18688	11739	701659	18688	704172	O-Ring, Inlet Manifold	3
127	46813	46813	46813	46813	46813	V-Packing	6
155	17784	20138	701658	17784	703292	O-Ring, V-Packing Spacer	3
159	17784	20138	701658	17784	703292	O-Ring, V-Packing Spacer	3

◆ Silicone oil/grease required *Review material codes for individual items (STG generally by be used as alternative)

VALVE KITS Two (2) valve kits required per pump

PUMP MODELS	NBR (STD) STHT (.3400)	FPM (.0110)	EPDM (.0220)◆	IPFE (.0770)
3545	33235	31262	31235	76636
3541D, 3541C, 3547	33835	31262	31264	76636

ITEM (Included in Valve Kits)						DESCRIPTION	QTY
163	26143	14331	701660		703293	O-Ring, Valve Seat	3
164	46822					Seat (3545)	3
		48393	48393		48393	Seat (3541D, 3541C, 3547)	3
166	43932					Valve (3545)	3
		44108	44108		44108	Valve (3541D, 3541C, 3547)	3
167	44109	44109	44109		44109	Spring	3
168	44728	44728	44728		44728	Retainer, Spring	3
170	44729	44729	44729		44729	Washer, Spring Retainer	3
172	89827	11747	701494		703169	O-Ring, Valve Plug	3
173	48364	48364	48364		48364	Backup-Ring, Valve Plug	3

◆ Silicone oil/grease required

CAUTIONS AND WARNINGS

All High-Pressure Systems require a primary pressure regulating device (i.e. regulator, unloader) and a secondary pressure relief device (i.e. pop-off valve, relief valve). Failure to install such relief devices could result in personal injury or damage to pump or property. Cat Pumps does not assume any liability or responsibility for the operation of a customer's high-pressure system.

Read all CAUTIONS and WARNINGS before commencing service or operation of any high-pressure system. The CAUTIONS and WARNINGS are included in each Service Manual and with each Accessory Data sheet. CAUTIONS and WARNINGS can also be viewed online at www.catpumps.com/dynamic-literature/cautions-and-warnings or can be requested directly from Cat Pumps.

WARRANTY

View the Limited Warranty on-line at www.catpumps.com/warranty.

CAT PUMPS 1681 94th Lane N.E., Minneapolis, MN 55449-4324 P: (763) 780-5440 F: (763) 780-2958 E: techsupport@catpumps.com www.catpumps.com

PN 993121 20123 Rev/N 4/20