



ދަރިވަރުންނަށް



ސަލާމް 1: ސަލާމް ދަރިވަރުންނަށް

ސަލާމް ދަރިވަރުންނަށް ސަލާމް ދަރިވަރުންނަށް ސަލާމް ދަރިވަރުންނަށް ސަލާމް ދަރިވަރުންނަށް ސަލާމް ދަރިވަރުންނަށް

2023 9 9: MNU-CA-PAMD/2023/103

40 (ނުވަތަ ބަލާ ފަތުވާ ސަލާމް ދަރިވަރުންނަށް ސަލާމް ދަރިވަރުންނަށް)

މި ސަލާމް ދަރިވަރުންނަށް ސަލާމް ދަރިވަރުންނަށް ސަލާމް ދަރިވަރުންނަށް ސަލާމް ދަރިވަރުންނަށް ސަލާމް ދަރިވަރުންނަށް

- ސަލާމް ދަރިވަރުންނަށް ސަލާމް ދަރިވަރުންނަށް ސަލާމް ދަރިވަރުންނަށް ސަލާމް ދަރިވަރުންނަށް ސަލާމް ދަރިވަރުންނަށް
- ސަލާމް ދަރިވަރުންނަށް ސަލާމް ދަރިވަރުންނަށް ސަލާމް ދަރިވަރުންނަށް ސަލާމް ދަރިވަރުންނަށް ސަލާމް ދަރިވަރުންނަށް

2023 13 10:30

10:30

ސަލާމް ދަރިވަރުންނަށް ސަލާމް ދަރިވަރުންނަށް ސަލާމް ދަރިވަރުންނަށް ސަލާމް ދަރިވަރުންނަށް ސަލާމް ދަރިވަރުންނަށް

2023 17 10:30

10:30

ސަލާމް ދަރިވަރުންނަށް ސަލާމް ދަރިވަރުންނަށް ސަލާމް ދަރިވަރުންނަށް ސަލާމް ދަރިވަރުންނަށް ސަލާމް ދަރިވަރުންނަށް

3345201, 3345134  
facilitiesmanagement@mnu-edu.mv

3345111, 3345110, 3345109  
procurement@mnu.edu.mv

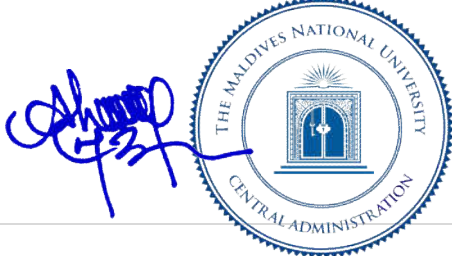



අර්ධසාර්වදේශිකව 2022-2023 වර්ෂයේදී කොටස් කඩපිටුවකින්  
 මුදල් 200,000,000.00 රුපියලක් පිරිසිදු කිරීමට මැදිහත්වීමට  
 පුළුල්ව තීරණය කළ බවට තීරණය කළ බවට තීරණය කළ බවට තීරණය කළ බවට  
 තීරණය කළ බවට තීරණය කළ බවට තීරණය කළ බවට තීරණය කළ බවට

මෙහිදී පැහැදිලි කර ඇති 3-වන කොටසේ සඳහන් කර ඇති තීරණයන් සඳහා

10 මුදල් ඉවත්කිරීමේ ප්‍රතිපත්ති

(අ) උපරිම මුදලක් පිරිසිදු කිරීමට මැදිහත්වීමට තීරණය කළ බවට තීරණය කළ බවට  
 තීරණය කළ බවට තීරණය කළ බවට තීරණය කළ බවට තීරණය කළ බවට  
 තීරණය කළ බවට තීරණය කළ බවට තීරණය කළ බවට තීරණය කළ බවට  
 තීරණය කළ බවට තීරණය කළ බවට තීරණය කළ බවට තීරණය කළ බවට

11 මුදල් ඉවත්කිරීමේ ප්‍රතිපත්ති

(ආ) මුදල් ඉවත්කිරීමේ ප්‍රතිපත්ති

(ඇ) මුදල් ඉවත්කිරීමේ ප්‍රතිපත්ති

(ඈ) මුදල් ඉවත්කිරීමේ ප්‍රතිපත්ති

(ඉ) මුදල් ඉවත්කිරීමේ ප්‍රතිපත්ති

මුදල් ඉවත්කිරීමේ ප්‍රතිපත්ති

(එ) මුදල් ඉවත්කිරීමේ ප්‍රතිපත්ති

















بِسْمِ اللّٰهِ الرَّحْمٰنِ الرَّحِیْمِ

بِسْمِ اللّٰهِ الرَّحْمٰنِ الرَّحِیْمِ

.....

بِسْمِ اللّٰهِ الرَّحْمٰنِ الرَّحِیْمِ

بِسْمِ اللّٰهِ الرَّحْمٰنِ الرَّحِیْمِ

.....

بِسْمِ اللّٰهِ الرَّحْمٰنِ الرَّحِیْمِ

.....

بِسْمِ اللّٰهِ الرَّحْمٰنِ الرَّحِیْمِ

بِسْمِ اللّٰهِ الرَّحْمٰنِ الرَّحِیْمِ

.....

بِسْمِ اللّٰهِ الرَّحْمٰنِ الرَّحِیْمِ

.....

.....

.....

.....

.....

بِسْمِ اللّٰهِ الرَّحْمٰنِ الرَّحِیْمِ

.....

.....

.....

.....

.....

**اِسْتِثْنَاءِ رِسْعَةِ زَمْرَتِ وَتَمَكُّنِ كَوْنِ مَعْمُورٍ، كَيْفِيَّةُ كَوْنِ رِجَالٍ كَثِيرٍ كَيْفِيَّةُ كَوْنِ نِسَاءٍ وَبَعْضِ نِسَاءٍ كَثِيرٍ**

<p>بِقَرَارِ مَجْلِسِ اِسْتِثْنَاءِ رِسْعَةِ زَمْرَتِ وَتَمَكُّنِ كَوْنِ مَعْمُورٍ</p>		
<p>تاریخ: _____</p>		
<p>محلہ: _____</p>		
<p>موضوع</p>	<p>تاریخ</p>	<p>تعداد</p>
<p>1. (بِقَرَارِ زَمْرَتِ كَوْنِ مَعْمُورٍ) كَوْنِ رِجَالٍ كَثِيرٍ 10 اِسْتِثْنَاءِ كَوْنِ نِسَاءٍ كَثِيرٍ كَوْنِ نِسَاءٍ كَثِيرٍ</p> <p>رِسْعَةِ زَمْرَتِ كَوْنِ مَعْمُورٍ: _____</p> <p>(تعداد: 10 اِسْتِثْنَاءِ، 02 اِسْتِثْنَاءِ)</p>	20	
<p>بِقَرَارِ مَجْلِسِ اِسْتِثْنَاءِ رِسْعَةِ زَمْرَتِ وَتَمَكُّنِ كَوْنِ مَعْمُورٍ</p> <p>تعداد: _____</p> <p>محلہ: _____</p> <p>تاریخ: _____</p> <p>موضوع: _____</p>		

<p>اِسْتِثْنَاءِ رِسْعَةِ زَمْرَتِ وَتَمَكُّنِ كَوْنِ مَعْمُورٍ</p>		
<p>موضوع</p>	<p>تاریخ</p>	<p>تعداد</p>
<p>2- اِسْتِثْنَاءِ رِسْعَةِ زَمْرَتِ كَوْنِ مَعْمُورٍ وَتَمَكُّنِ كَوْنِ مَعْمُورٍ كَوْنِ نِسَاءٍ كَثِيرٍ كَوْنِ نِسَاءٍ كَثِيرٍ</p> <p>رِسْعَةِ زَمْرَتِ كَوْنِ مَعْمُورٍ: <input checked="" type="checkbox"/></p> <p>تعداد: _____</p> <p>محلہ: _____</p> <p>تاریخ: _____</p>	10	
<p>3- اِسْتِثْنَاءِ رِسْعَةِ زَمْرَتِ كَوْنِ مَعْمُورٍ وَتَمَكُّنِ كَوْنِ مَعْمُورٍ كَوْنِ نِسَاءٍ كَثِيرٍ كَوْنِ نِسَاءٍ كَثِيرٍ</p> <p>تعداد: 500,000 اِسْتِثْنَاءِ كَوْنِ نِسَاءٍ كَثِيرٍ كَوْنِ نِسَاءٍ كَثِيرٍ</p> <p>محلہ: _____</p> <p>تاریخ: _____</p>	20	
<p>بِقَرَارِ مَجْلِسِ اِسْتِثْنَاءِ رِسْعَةِ زَمْرَتِ وَتَمَكُّنِ كَوْنِ مَعْمُورٍ</p> <p>تعداد: _____</p> <p>محلہ: _____</p> <p>تاریخ: _____</p> <p>موضوع: _____</p>		

تعمیراتی منصوبہ کی تفصیل:			
محلہ/ضلع	تعمیراتی منصوبہ کی تفصیل	تعمیراتی منصوبہ کی تفصیل	تعمیراتی منصوبہ کی تفصیل
			تعمیراتی منصوبہ کی تفصیل
			تعمیراتی منصوبہ کی تفصیل (تعمیراتی)
			تعمیراتی منصوبہ کی تفصیل (تعمیراتی)
			تعمیراتی منصوبہ کی تفصیل

تعمیراتی منصوبہ کی تفصیل	تعمیراتی منصوبہ کی تفصیل
تعمیراتی منصوبہ کی تفصیل:	تعمیراتی منصوبہ کی تفصیل:
تعمیراتی منصوبہ کی تفصیل:	تعمیراتی منصوبہ کی تفصیل:
تعمیراتی منصوبہ کی تفصیل:	تعمیراتی منصوبہ کی تفصیل:
تعمیراتی منصوبہ کی تفصیل:	تعمیراتی منصوبہ کی تفصیل:

### تعمیراتی منصوبہ کی تفصیل

تعمیراتی منصوبہ کی تفصیل (تعمیراتی) : (05) (تعمیراتی)

تعمیراتی منصوبہ کی تفصیل	تعمیراتی منصوبہ کی تفصیل	تعمیراتی منصوبہ کی تفصیل	تعمیراتی منصوبہ کی تفصیل
20	20	20	تعمیراتی منصوبہ کی تفصیل
			تعمیراتی منصوبہ کی تفصیل
تعمیراتی منصوبہ کی تفصیل 3 (تعمیراتی) (تعمیراتی) :			

تعمیراتی منصوبہ کی تفصیل (15) (تعمیراتی)

تعمیراتی منصوبہ کی تفصیل (50% (تعمیراتی)

تعمیراتی منصوبہ کی تفصیل			
#	تعمیراتی منصوبہ کی تفصیل	تعمیراتی منصوبہ کی تفصیل	تعمیراتی منصوبہ کی تفصیل

نمبر ۱۰۰	نمبر ۱۰۰	نمبر ۱۰۰	نمبر ۱۰۰
1			
2			
3			
4			
5			
6			
			۱۰۰

نمبر ۱۰۰	نمبر ۱۰۰
نمبر ۱۰۰	نمبر ۱۰۰
نمبر ۱۰۰	نمبر ۱۰۰
نمبر ۱۰۰	نمبر ۱۰۰



## BID SECURITY FORMAT

The Issuing Bank shall fill in this Bank Guarantee Form in accordance with the instructions indicated.

\_\_\_\_\_ [Bank's Name, and Address of Issuing Branch or Office]

**Beneficiary:** \_\_\_\_\_ [Name and Address of Procuring Entity]

**Date:** \_\_\_\_\_

**BID GUARANTEE No.:** \_\_\_\_\_

We have been informed that [name of the Bidder] (hereinafter called "the Bidder") has submitted to you its bid dated (hereinafter called "the Bid") for the execution of [name of contract] under Invitation for Bids No. [Procurement Reference number] ("the IFB").

Furthermore, we understand that, according to your conditions, bids must be supported by a bid guarantee.

At the request of the Bidder, we [name of Bank] hereby irrevocably undertake to pay you any sum or sums not exceeding in total an amount of [amount in figures] ([amount in words]) upon receipt by us of your first demand in writing accompanied by a written statement stating that the Bidder is in breach of its obligation(s) under the bid conditions, because the Bidder:

- (a) has withdrawn its Bid during the period of bid validity specified by the Bidder in the Form of Bid; or
- (b) having been notified of the acceptance of its Bid by the Procuring Entity during the period of bid validity, (i) fails or refuses to execute the Contract Form; or (ii) fails or refuses to furnish the performance security, if required, in accordance with the Instructions to Bidders.

This guarantee will expire: (a) if the Bidder is the successful Bidder, upon our receipt of copies of the contract signed by the Bidder and the performance security issued to you upon the instruction of the Bidder; or (b) if the Bidder is not the successful Bidder, upon the earlier of (i) our receipt of a copy of your notification to the Bidder of the name of the successful Bidder; or (ii) twenty-eight days after the expiration of the Bidder's Bid.

Consequently, any demand for payment under this guarantee must be received by us at the office on or before that date.

This guarantee is subject to the Uniform Rules for Demand Guarantees, ICC Publication No. 458.

\_\_\_\_\_  
[signature(s)]



## PERFORMANCE GUARANTEE FORMAT

*[The issuing bank, as requested by the successful Bidder, shall fill in this form in accordance with the instructions indicated]*

Date: *[insert date (as day, month, and year)]*

Title of the procurement: *[Insert general title of the procurement]*

Procurement Reference No: *[insert reference]*

Bank's Branch or Office: *[insert complete name of Guarantor]*

**Beneficiary:** *[insert complete name of Procuring Entity]*

**PERFORMANCE GUARANTEE No.:** *[insert Performance Guarantee number]*

We have been informed that *[insert complete name of Supplier]* (hereinafter called "the Supplier") has entered into Contract No. *[insert number]* dated *[insert day and month]*, *[insert year]* with you, for the supply of *[description of Goods and related Services]* (hereinafter called "the Contract").

Furthermore, we understand that, according to the conditions of the Contract, a Performance Guarantee is required.

At the request of the Supplier, we hereby irrevocably undertake to pay you any sum(s) not exceeding *[insert amount(s)<sup>1</sup> in figures and words]* upon receipt by us of your first demand in writing declaring the Supplier to be in default under the Contract, without cavil or argument, or your needing to prove or to show grounds or reasons for your demand or the sum specified therein.

This Guarantee shall expire no later than the *[insert number]* day of *[insert month]* *[insert year]*,<sup>2</sup> and any demand for payment under it must be received by us at this office on or before that date. We agree to a one-time extension of this Guarantee for a period not to exceed *[six months]* *[one year]*, in response to the Procuring Entity's written request for such extension, such request to be presented to us before the expiry of the Guarantee.

This guarantee is subject to the Uniform Rules for Demand Guarantees, ICC Publication No. 458, except that subparagraph (ii) of Sub-article 20(a) is hereby excluded.

.....  
*[signatures of authorized representatives of the bank]*

<sup>1</sup> The Bank shall insert the amount(s) specified in the SCC and denominated, as specified in the SCC, either in the currency(ies) of the Contract or a freely convertible currency acceptable to the Procuring Entity.

<sup>2</sup> Dates established in accordance with Clause 18.4 of the General Conditions of Contract ("GCC"), taking into account any warranty obligations of the Supplier under Clause 16.2 of the GCC intended to be secured by a partial Performance Guarantee.

## BANK GUARANTEE FOR ADVANCE PAYMENT

*[The bank, as requested by the successful Bidder, shall fill in this form in accordance with the instructions indicated.]*

Date: *[insert date (as day, month, and year)]*

Title of the procurement: *[Insert general title of the procurement]*

Procurement Reference No: *[insert reference]*

*[Issuing bank's letterhead]*

**Beneficiary:** *[insert legal name and address of Procuring Entity]*

**ADVANCE PAYMENT GUARANTEE No.:** *[insert Advance Payment Guarantee no.]*

We, *[insert legal name and address of bank]*, have been informed that *[insert complete name and address of Supplier]* (hereinafter called "the Supplier") has entered into Contract No. *[insert number]* dated *[insert date of Agreement]* with you, for the supply of *[insert types of Goods to be delivered]* (hereinafter called "the Contract").

Furthermore, we understand that, according to the conditions of the Contract, an advance is to be made against an advance payment guarantee.

At the request of the Supplier, we hereby irrevocably undertake to pay you any sum or sums not exceeding in total an amount of *[insert amount(s)<sup>3</sup> in figures and words]* upon receipt by us of your first demand in writing declaring that the Supplier is in breach of its obligation under the Contract because the Supplier used the advance payment for purposes other than toward delivery of the Goods.

It is a condition for any claim and payment under this Guarantee to be made that the advance payment referred to above must have been received by the Supplier on its account *[insert number and domicile of the account]*

This Guarantee shall remain valid and in full effect from the date of the advance payment received by the Supplier under the Contract until *[insert date<sup>4</sup>]*. We agree to a one-time extension of this Guarantee for a period not to exceed *[six months][one year]*, in response to the Procuring Entity's written request for such extension, such request to be presented to us before the expiry of the Guarantee.

This Guarantee is subject to the Uniform Rules for Demand Guarantees, ICC Publication No. 458.

\_\_\_\_\_  
*[signature(s) of authorized representative(s) of the bank]*

<sup>3</sup> The issuing bank shall insert the amount(s) specified in the SCC and denominated, as specified in the SCC, either in the currency(ies) of the Contract or a freely convertible currency acceptable to the Procuring Entity.

<sup>4</sup> Insert the Delivery date stipulated in the Contract Delivery Schedule.

ސަލާމް ސަލާމް 3: ބަލާ ސަލާމް ސަލާމް ސަލާމް / ސަލާމް ސަލާމް ސަލާމް  
ސަލާމް ސަލާމް ސަލާމް ސަލާމް ސަލާމް ސަލާމް ސަލާމް ސަލާމް

















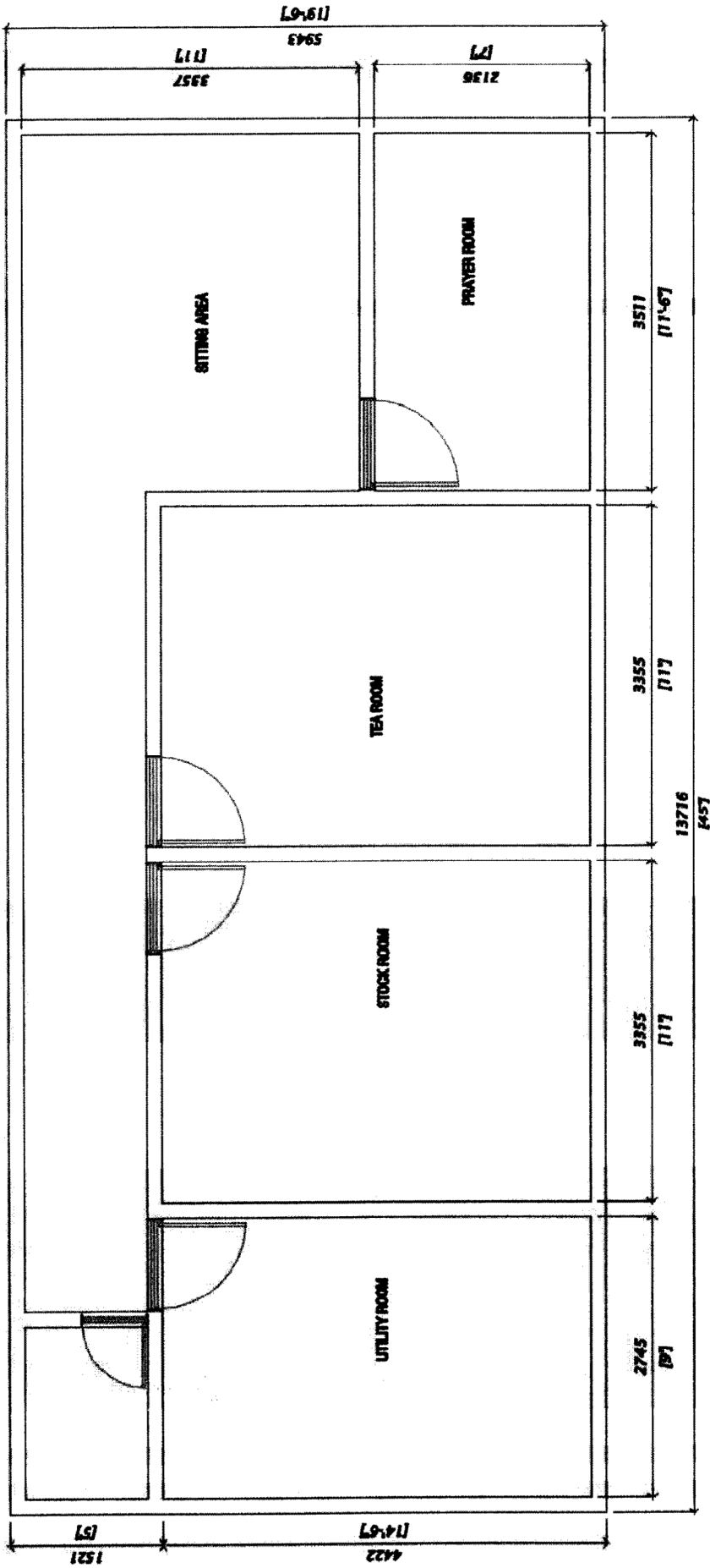

## FLOOR PLAN

SCALE 1:100

Project Title: **Design of buildings**

**CMS - ROOFING WORK  
WITH ADDITIONAL WORK (VILLI MALE')**

MALDIVES NATIONAL UNIVERSITY

Facilities Management Section

Drawn: Suman  
 Contact: 9948103 / 9948154  
 Email: [suman@facilities.mnu.ac.mv](mailto:suman@facilities.mnu.ac.mv)  
 All dimensions are in millimeters, and must be confirmed at the site by the contractor.



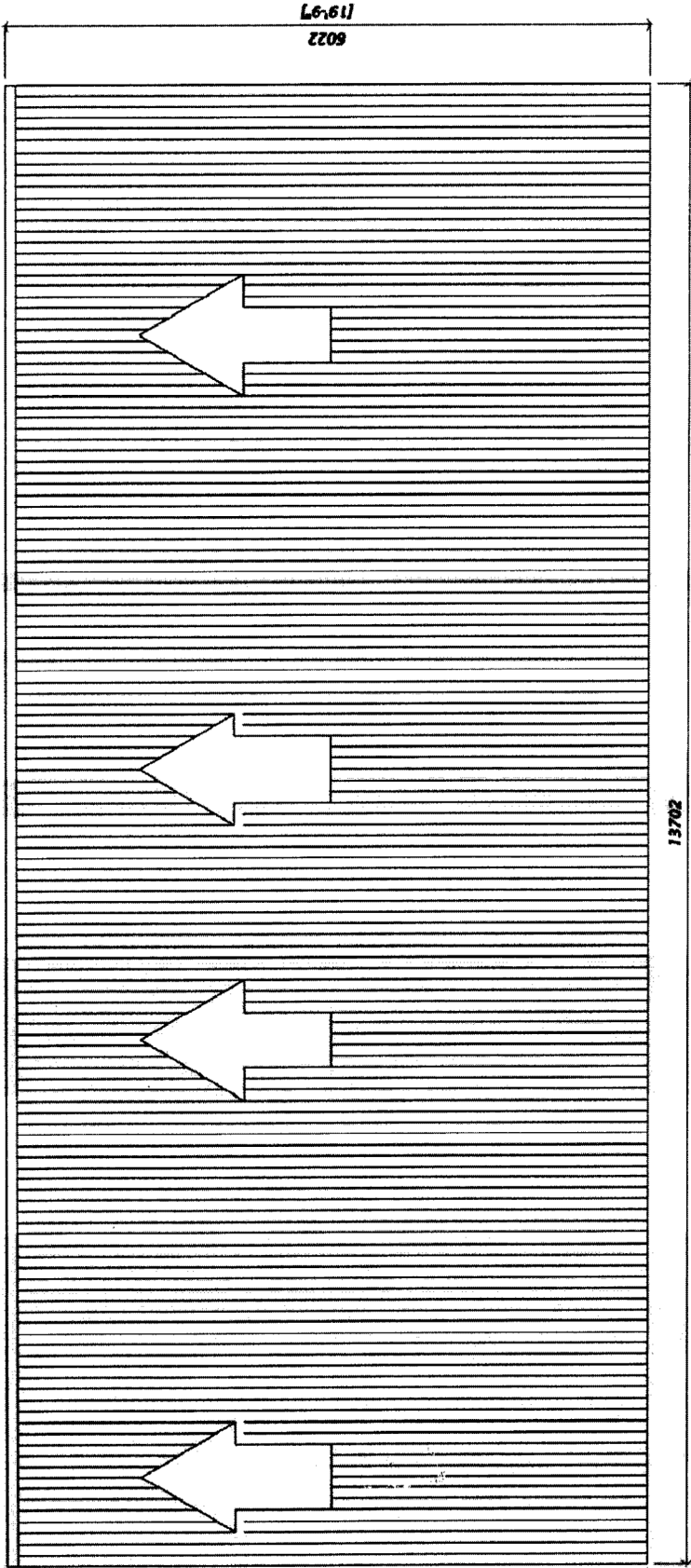

**ROAD**

13702  
6022

**ROOF PLAN**

SCALE 1:100

Project Title: **Roofing**

**CMS - ROOFING WORK  
WITH ADDITIONAL WORK (VILLI MALE')**

THE MALDIVES NATIONAL UNIVERSITY

Facilities Management Section

Drawn: Shamsan  
Checked: 19/07/2022 / 19/07/2024  
All dimensions are indicated, and must be confirmed at the site by the contractor.



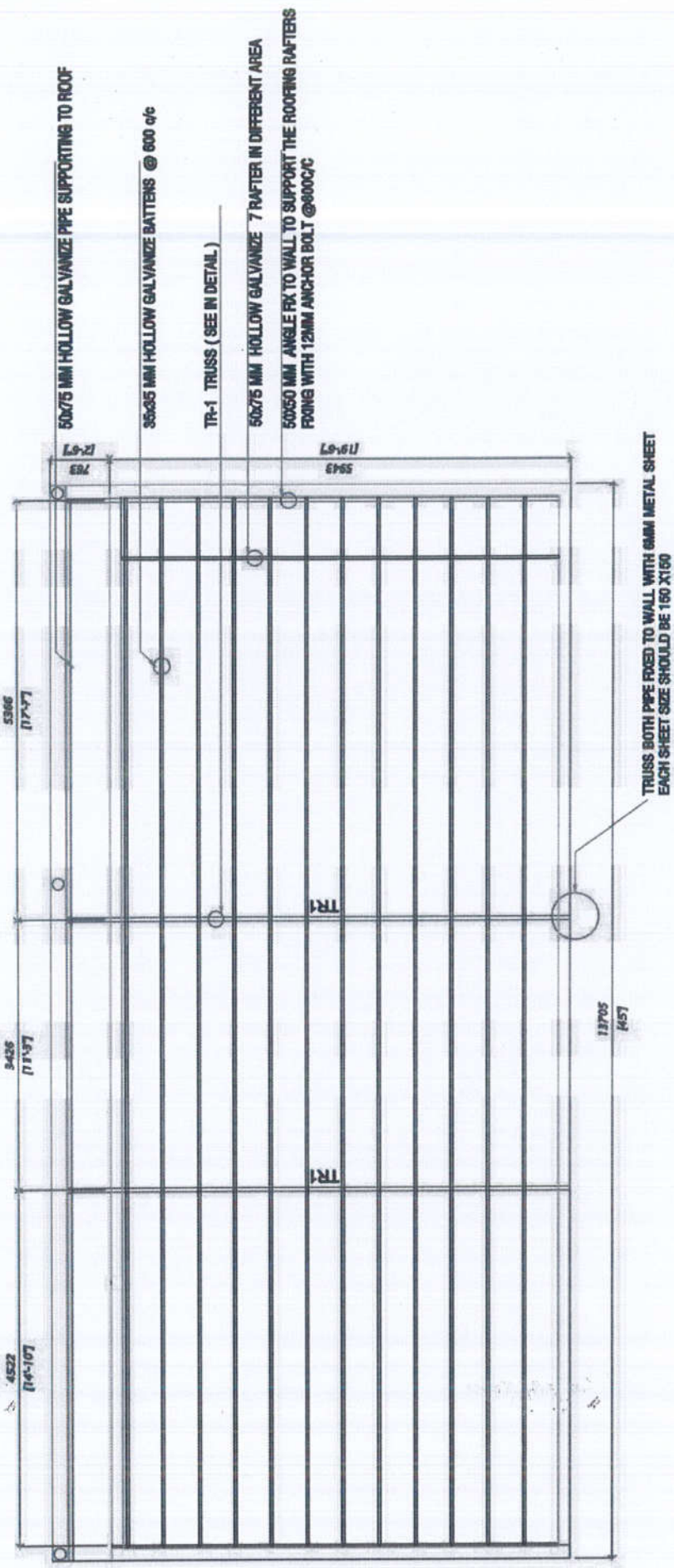

**ROOF FRAMING PLAN**

SCALE 1:100

Project Title: **OMS - ROOFING WORK WITH ADDITIONAL WORK (VILLI MALE)**

Client: MALDIVES NATIONAL UNIVERSITY  
 Faculty: Facilities Management Division

Drawn by: *[Signature]*  
 Checked by: *[Signature]*  
 Approved by: *[Signature]*





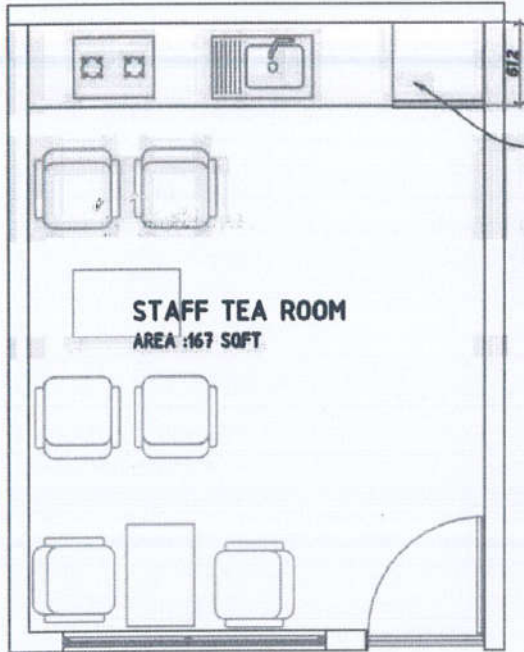

kitchen cabinets on top and bottom with medium density fiberboard counter top with 16 mm granite sheet (SEE DETAIL-01)

## KITCHEN PLAN (ANNEX-4)

SCALE 1: 100

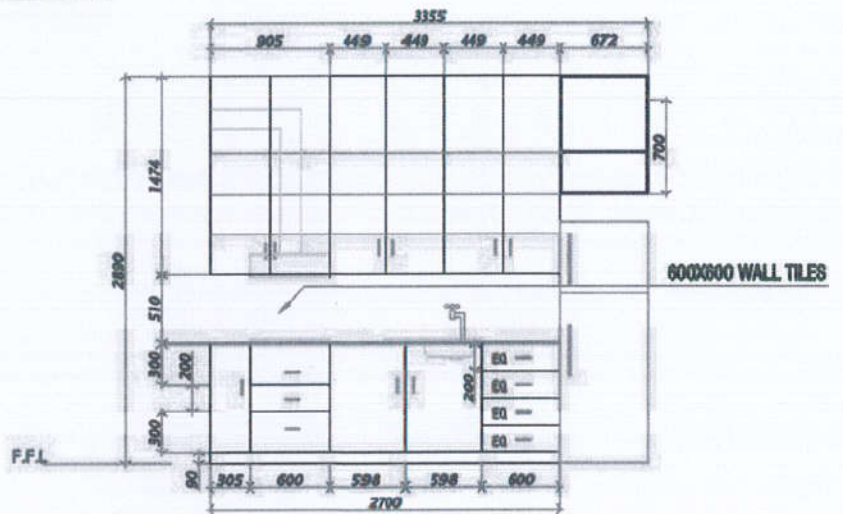

## KITCHEN PLAN -DETAIL

SCALE 1: 100

Project Title

Date 02/08/2023

### CMS - ROOFING WORK WITH ADDITIONAL WORK (VILLI MALE ')

MALDIVES NATIONAL UNIVERSITY

Facilities Management Section

Email: [facilitiesmanagementsection@mnu.edu.mv](mailto:facilitiesmanagementsection@mnu.edu.mv)

All dimensions are indicative, and must be confirmed at the site by the contractor.

Drawn : Sursan

Contact : 3346192 / 3346194



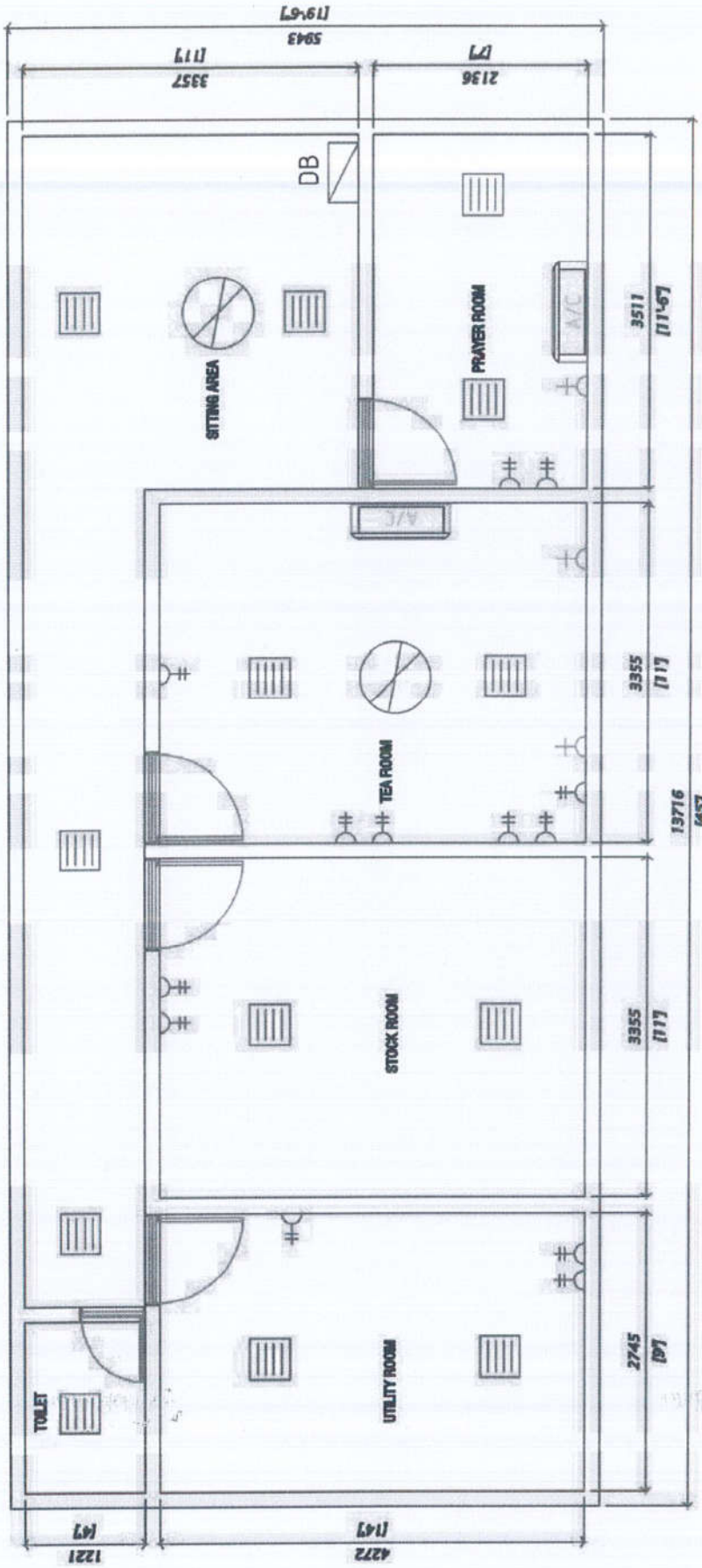

LEGEND	
	DISTRIBUTION BOARD
	LED LIGHT (SURFACE MOUNT) 24W
	POWER OUTLET 13Amp Double
	POWER OUTLET 16 Amp
	CEILING FAN 4F
	AIR CONDITIONER 9K BTU

**ANNEX-3**  
SCALE 1:100

Project Title: **OMS - ROOFING WORK WITH ADDITIONAL WORK (VILLI MALE)**

Date: 03/08/2023

MALDIVES NATIONAL UNIVERSITY  
Facilities Management Section

Drawn: J. Suman  
Checked: S. Suman / S. Suman  
All dimensions are in meters, and shall be confirmed at the site by the contractor.



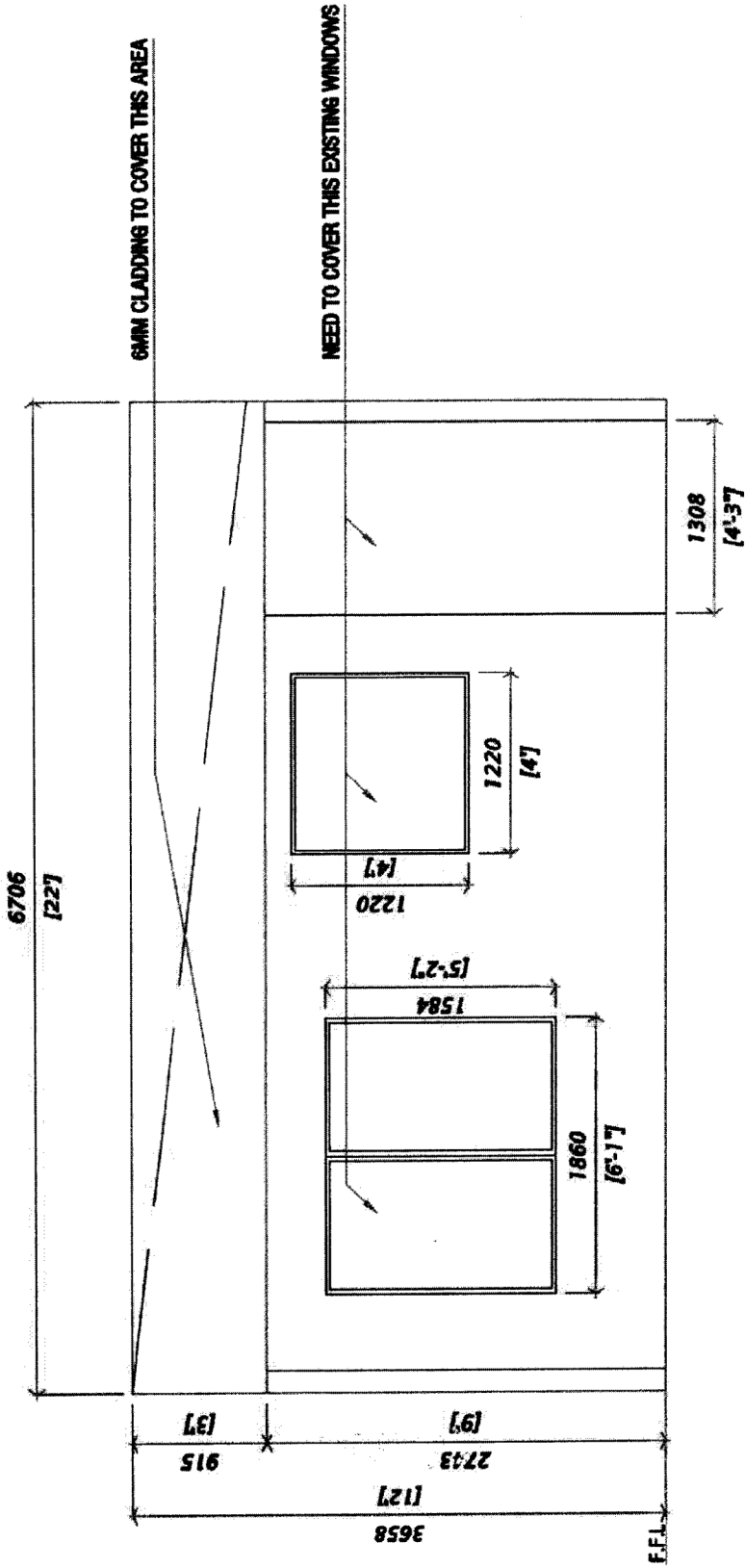

**ANNEX -1**

SCALE 1:100

**Project Title** Debate centres

**CMS - ROOFING WORK  
WITH ADDITIONAL WORK (VILLI MALE ')**

**MALDIVES NATIONAL UNIVERSITY**  
Facilities Management Section

Drawn : Surivan  
Checked : 2024/12/20/2024  
Email: facilitiesmanagement@mnul.mv  
All dimensions are in millimeters, and must be confirmed at the site by the contractor.



# ANNEX-2

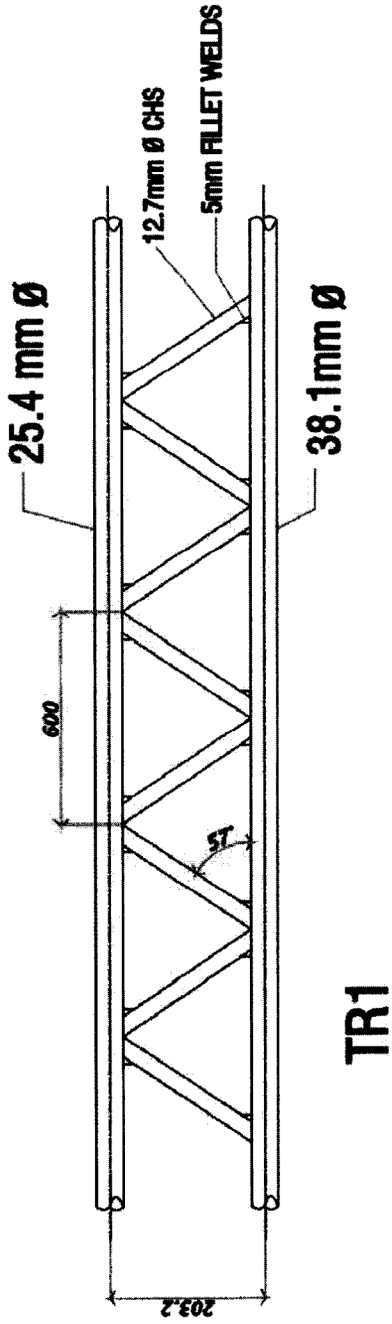

## DETAIL DRAWING

Project Title	Date
<b>CHS - ROOFING WORK WITH ADDITIONAL WORK (VILLI MALE ')</b>	
MALDIVES NATIONAL UNIVERSITY Facilities Management Section	Drawn : Sunain Checked: suresh/raheem All dimensions are indicated, and must be confirmed at the site by the contractor.

