



ސަލާސަނަ: ސަލާސަނަ ޔަޝްރަތު ސަލާސަނަ

Table with 2 columns containing procurement details: 1) 2023 13th week (MNU-CA-PAMD/2023/129) - 30 days (e-procurement), 2) 2023 18th week - 10:00 (e-procurement), 3) 2023 21st week - 10:00 (e-procurement).

Handwritten signature and circular official stamp of The Maldives National University.















**חוקר דבריו ומחבריו במסגרת הפרויקט 'הדיון'**

(תשובות שאלות התראת המדען המזרחי  פרטים )

<p>חומר מסווג מס' חקירה <input checked="" type="checkbox"/></p>	<p>חומר מסווג מס' חקירה <input type="checkbox"/></p>	<p>מס' חקירה</p>	<p>#</p>
		<p>חוקר דבריו ומחבריו במסגרת הפרויקט 'הדיון' (פרטים-1 י"ד) ד"ר ח' (חומר מסווג)</p>	1
		<p>התקשרות של מחבר ב' לחבר א' המיושמת על ידי א' ב' ג' ד' ו' ז' ח' ט' י' י"א י"ב י"ג י"ד י"ה י"ו י"ז י"ח י"ט כ' כ"א כ"ב כ"ג כ"ד כ"ה כ"ו כ"ז כ"ח כ"ט ל' ל"א ל"ב ל"ג ל"ד ל"ה ל"ו ל"ז ל"ח ל"ט מ' מ"א מ"ב מ"ג מ"ד מ"ה מ"ו מ"ז מ"ח מ"ט נ' נ"א נ"ב נ"ג נ"ד נ"ה נ"ו נ"ז נ"ח נ"ט ס' ס"א ס"ב ס"ג ס"ד ס"ה ס"ו ס"ז ס"ח ס"ט ע' ע"א ע"ב ע"ג ע"ד ע"ה ע"ו ע"ז ע"ח ע"ט פ' פ"א פ"ב פ"ג פ"ד פ"ה פ"ו פ"ז פ"ח פ"ט צ' צ"א צ"ב צ"ג צ"ד צ"ה צ"ו צ"ז צ"ח צ"ט ק' ק"א ק"ב ק"ג ק"ד ק"ה ק"ו ק"ז ק"ח ק"ט ר' ר"א ר"ב ר"ג ר"ד ר"ה ר"ו ר"ז ר"ח ר"ט ש' ש"א ש"ב ש"ג ש"ד ש"ה ש"ו ש"ז ש"ח ש"ט ט"א ט"ב ט"ג ט"ד ט"ה ט"ו ט"ז ט"ח ט"ט י"א י"ב י"ג י"ד י"ה י"ו י"ז י"ח י"ט י"א י"ב י"ג י"ד י"ה י"ו י"ז י"ח י"ט</p>	2
		<p>דבריו של מחבר א'</p>	3
		<p>תשובת מחבר ב' לשאלת מחבר א' (פרטים-2 י"ד) א' ב' ג' ד' ו' ז' ח' ט' י' י"א י"ב י"ג י"ד י"ה י"ו י"ז י"ח י"ט</p>	4
		<p>דיון על תשובת מחבר א' (פרטים-4 י"ד) א' ב' ג' ד' ו' ז' ח' ט' י' י"א י"ב י"ג י"ד י"ה י"ו י"ז י"ח י"ט</p>	5
		<p>תשובת מחבר א' לשאלת מחבר ב' (פרטים-3 י"ד) א' ב' ג' ד' ו' ז' ח' ט' י' י"א י"ב י"ג י"ד י"ה י"ו י"ז י"ח י"ט</p>	6
		<p>התקשרות של מחבר א' לחבר ב' (פרטים-3 י"ד) א' ב' ג' ד' ו' ז' ח' ט' י' י"א י"ב י"ג י"ד י"ה י"ו י"ז י"ח י"ט</p>	7
		<p>תשובת מחבר א' לשאלת מחבר ב' (פרטים-3 י"ד) א' ב' ג' ד' ו' ז' ח' ט' י' י"א י"ב י"ג י"ד י"ה י"ו י"ז י"ח י"ט</p>	8
		<p>דיון על תשובת מחבר א' (פרטים-3 י"ד) א' ב' ג' ד' ו' ז' ח' ט' י' י"א י"ב י"ג י"ד י"ה י"ו י"ז י"ח י"ט</p>	9
		<p>תשובת מחבר א' לשאלת מחבר ב' (פרטים-3 י"ד) א' ב' ג' ד' ו' ז' ח' ט' י' י"א י"ב י"ג י"ד י"ה י"ו י"ז י"ח י"ט</p>	10
		<p>תשובת מחבר א' לשאלת מחבר ב' (פרטים-3 י"ד) א' ב' ג' ד' ו' ז' ח' ט' י' י"א י"ב י"ג י"ד י"ה י"ו י"ז י"ח י"ט</p>	11
		<p>התקשרות של מחבר א' לחבר ב' (פרטים-3 י"ד) א' ב' ג' ד' ו' ז' ח' ט' י' י"א י"ב י"ג י"ד י"ה י"ו י"ז י"ח י"ט</p>	12
		<p>התקשרות של מחבר א' לחבר ב' (פרטים-3 י"ד) א' ב' ג' ד' ו' ז' ח' ט' י' י"א י"ב י"ג י"ד י"ה י"ו י"ז י"ח י"ט</p>	13
		<p>דבריו של מחבר א'</p>	14
		<p>תשובת מחבר א' לשאלת מחבר ב' (פרטים-3 י"ד) א' ב' ג' ד' ו' ז' ח' ט' י' י"א י"ב י"ג י"ד י"ה י"ו י"ז י"ח י"ט</p>	15
		<p>תשובת מחבר א' לשאלת מחבר ב' (פרטים-3 י"ד) א' ב' ג' ד' ו' ז' ח' ט' י' י"א י"ב י"ג י"ד י"ה י"ו י"ז י"ח י"ט</p>	16
		<p>תשובת מחבר א' לשאלת מחבר ב' (פרטים-3 י"ד) א' ב' ג' ד' ו' ז' ח' ט' י' י"א י"ב י"ג י"ד י"ה י"ו י"ז י"ח י"ט</p>	17

החומר מסווג במסגרת הפרויקט 'הדיון'.

**הערות:** חומר מסווג זה נמצא במסגרת הפרויקט 'הדיון' ונמצא במקומות שונים באתר האינטרנט של המוסד. חומר מסווג זה נמצא במסגרת הפרויקט 'הדיון' ונמצא במקומות שונים באתר האינטרנט של המוסד. חומר מסווג זה נמצא במסגרת הפרויקט 'הדיון' ונמצא במקומות שונים באתר האינטרנט של המוסד. חומר מסווג זה נמצא במסגרת הפרויקט 'הדיון' ונמצא במקומות שונים באתר האינטרנט של המוסד. חומר מסווג זה נמצא במסגרת הפרויקט 'הדיון' ונמצא במקומות שונים באתר האינטרנט של המוסד.

بِسْمِ اللَّهِ الرَّحْمَنِ الرَّحِيمِ وَبِذَلِكَ نَفَعْنَا النَّاسَ

بِسْمِ اللَّهِ الرَّحْمَنِ الرَّحِيمِ وَبِذَلِكَ نَفَعْنَا النَّاسَ

بِسْمِ اللَّهِ الرَّحْمَنِ الرَّحِيمِ وَبِذَلِكَ نَفَعْنَا النَّاسَ

بِسْمِ اللَّهِ الرَّحْمَنِ الرَّحِيمِ وَبِذَلِكَ نَفَعْنَا النَّاسَ

بِسْمِ اللَّهِ الرَّحْمَنِ الرَّحِيمِ وَبِذَلِكَ نَفَعْنَا النَّاسَ

بِسْمِ اللَّهِ الرَّحْمَنِ الرَّحِيمِ وَبِذَلِكَ نَفَعْنَا النَّاسَ

بِسْمِ اللَّهِ الرَّحْمَنِ الرَّحِيمِ وَبِذَلِكَ نَفَعْنَا النَّاسَ

بِسْمِ اللَّهِ الرَّحْمَنِ الرَّحِيمِ وَبِذَلِكَ نَفَعْنَا النَّاسَ

بِسْمِ اللَّهِ الرَّحْمَنِ الرَّحِيمِ وَبِذَلِكَ نَفَعْنَا النَّاسَ



تجزیاتی پیمانہ کی تفصیل:			
تجزیاتی پیمانہ کی تفصیل	تجزیاتی پیمانہ کی تفصیل	تجزیاتی پیمانہ کی تفصیل	تجزیاتی پیمانہ کی تفصیل
			تجزیاتی پیمانہ کی تفصیل
			تجزیاتی پیمانہ کی تفصیل (تجزیاتی)
			تجزیاتی پیمانہ کی تفصیل (تجزیاتی)
			تجزیاتی پیمانہ کی تفصیل

تجزیاتی پیمانہ کی تفصیل (تجزیاتی)	تجزیاتی پیمانہ کی تفصیل:
تجزیاتی پیمانہ کی تفصیل:	تجزیاتی پیمانہ کی تفصیل:
تجزیاتی پیمانہ کی تفصیل:	تجزیاتی پیمانہ کی تفصیل:
تجزیاتی پیمانہ کی تفصیل:	تجزیاتی پیمانہ کی تفصیل:

### تجزیاتی پیمانہ کی تفصیل

تجزیاتی پیمانہ کی تفصیل 3 اجزائی میں (تجزیاتی پیمانہ کی تفصیل، تجزیاتی پیمانہ کی تفصیل، تجزیاتی پیمانہ کی تفصیل) : (05 تجزیاتی پیمانہ کی تفصیل)

تجزیاتی پیمانہ کی تفصیل	تجزیاتی پیمانہ کی تفصیل	تجزیاتی پیمانہ کی تفصیل	تجزیاتی پیمانہ کی تفصیل
20	20	20	تجزیاتی پیمانہ کی تفصیل
تجزیاتی پیمانہ کی تفصیل 3 اجزائی میں (تجزیاتی پیمانہ کی تفصیل، تجزیاتی پیمانہ کی تفصیل، تجزیاتی پیمانہ کی تفصیل):			

تجزیاتی پیمانہ کی تفصیل (15 تجزیاتی پیمانہ کی تفصیل):

تجزیاتی پیمانہ کی تفصیل 50% تجزیاتی پیمانہ کی تفصیل

تجزیاتی پیمانہ کی تفصیل			
#	تجزیاتی پیمانہ کی تفصیل	تجزیاتی پیمانہ کی تفصیل	تجزیاتی پیمانہ کی تفصیل

تاریخ	تعداد	تعداد	تعداد
تعداد	تعداد	تعداد	تعداد
1			
2			
3			
4			
5			
6			
جمعاً			

تعداد	تعداد
تعداد	تعداد
تعداد	تعداد
تعداد	تعداد



## BID SECURITY FORMAT

The Issuing Bank shall fill in this Bank Guarantee Form in accordance with the instructions indicated.

\_\_\_\_\_ [Bank's Name, and Address of Issuing Branch or Office]

**Beneficiary:** \_\_\_\_\_ [Name and Address of Procuring Entity]

**Date:** \_\_\_\_\_

**BID GUARANTEE No.:** \_\_\_\_\_

We have been informed that [name of the Bidder] (hereinafter called "the Bidder") has submitted to you its bid dated (hereinafter called "the Bid") for the execution of [name of contract] under Invitation for Bids No. [Procurement Reference number] ("the IFB").

Furthermore, we understand that, according to your conditions, bids must be supported by a bid guarantee.

At the request of the Bidder, we [name of Bank] hereby irrevocably undertake to pay you any sum or sums not exceeding in total an amount of [amount in figures] ([amount in words]) upon receipt by us of your first demand in writing accompanied by a written statement stating that the Bidder is in breach of its obligation(s) under the bid conditions, because the Bidder:

- (a) has withdrawn its Bid during the period of bid validity specified by the Bidder in the Form of Bid; or
- (b) having been notified of the acceptance of its Bid by the Procuring Entity during the period of bid validity, (i) fails or refuses to execute the Contract Form; or (ii) fails or refuses to furnish the performance security, if required, in accordance with the Instructions to Bidders.

This guarantee will expire: (a) if the Bidder is the successful Bidder, upon our receipt of copies of the contract signed by the Bidder and the performance security issued to you upon the instruction of the Bidder; or (b) if the Bidder is not the successful Bidder, upon the earlier of (i) our receipt of a copy of your notification to the Bidder of the name of the successful Bidder; or (ii) twenty-eight days after the expiration of the Bidder's Bid.

Consequently, any demand for payment under this guarantee must be received by us at the office on or before that date.

This guarantee is subject to the Uniform Rules for Demand Guarantees, ICC Publication No. 458.

\_\_\_\_\_  
[signature(s)]

## PERFORMANCE GUARANTEE FORMAT

*[The issuing bank, as requested by the successful Bidder, shall fill in this form in accordance with the instructions indicated]*

Date: *[insert date (as day, month, and year)]*

Title of the procurement: *[Insert general title of the procurement]*

Procurement Reference No: *[insert reference]*

Bank's Branch or Office: *[insert complete name of Guarantor]*

**Beneficiary:** *[insert complete name of Procuring Entity]*

**PERFORMANCE GUARANTEE No.:** *[insert Performance Guarantee number]*

We have been informed that *[insert complete name of Supplier]* (hereinafter called "the Supplier") has entered into Contract No. *[insert number]* dated *[insert day and month]*, *[insert year]* with you, for the supply of *[description of Goods and related Services]* (hereinafter called "the Contract").

Furthermore, we understand that, according to the conditions of the Contract, a Performance Guarantee is required.

At the request of the Supplier, we hereby irrevocably undertake to pay you any sum(s) not exceeding *[insert amount(s)<sup>1</sup> in figures and words]* upon receipt by us of your first demand in writing declaring the Supplier to be in default under the Contract, without cavil or argument, or your needing to prove or to show grounds or reasons for your demand or the sum specified therein.

This Guarantee shall expire no later than the *[insert number]* day of *[insert month]* *[insert year]*,<sup>2</sup> and any demand for payment under it must be received by us at this office on or before that date. We agree to a one-time extension of this Guarantee for a period not to exceed *[six months]* *[one year]*, in response to the Procuring Entity's written request for such extension, such request to be presented to us before the expiry of the Guarantee.

This guarantee is subject to the Uniform Rules for Demand Guarantees, ICC Publication No. 458, except that subparagraph (ii) of Sub-article 20(a) is hereby excluded.

.....

*[signatures of authorized representatives of the bank]*

<sup>1</sup> The Bank shall insert the amount(s) specified in the SCC and denominated, as specified in the SCC, either in the currency(ies) of the Contract or a freely convertible currency acceptable to the Procuring Entity.

<sup>2</sup> Dates established in accordance with Clause 18.4 of the General Conditions of Contract ("GCC"), taking into account any warranty obligations of the Supplier under Clause 16.2 of the GCC intended to be secured by a partial Performance Guarantee.



## BANK GUARANTEE FOR ADVANCE PAYMENT

*[The bank, as requested by the successful Bidder, shall fill in this form in accordance with the instructions indicated.]*

Date: *[insert date (as day, month, and year)]*

Title of the procurement: *[Insert general title of the procurement]*

Procurement Reference No: *[insert reference]*

*[Issuing bank's letterhead]*

**Beneficiary:** *[insert legal name and address of Procuring Entity]*

**ADVANCE PAYMENT GUARANTEE No.:** *[insert Advance Payment Guarantee no.]*

We, *[insert legal name and address of bank]*, have been informed that *[insert complete name and address of Supplier]* (hereinafter called "the Supplier") has entered into Contract No. *[insert number]* dated *[insert date of Agreement]* with you, for the supply of *[insert types of Goods to be delivered]* (hereinafter called "the Contract").

Furthermore, we understand that, according to the conditions of the Contract, an advance is to be made against an advance payment guarantee.

At the request of the Supplier, we hereby irrevocably undertake to pay you any sum or sums not exceeding in total an amount of *[insert amount(s)<sup>3</sup> in figures and words]* upon receipt by us of your first demand in writing declaring that the Supplier is in breach of its obligation under the Contract because the Supplier used the advance payment for purposes other than toward delivery of the Goods.

It is a condition for any claim and payment under this Guarantee to be made that the advance payment referred to above must have been received by the Supplier on its account *[insert number and domicile of the account]*

This Guarantee shall remain valid and in full effect from the date of the advance payment received by the Supplier under the Contract until *[insert date<sup>4</sup>]*. We agree to a one-time extension of this Guarantee for a period not to exceed *[six months][one year]*, in response to the Procuring Entity's written request for such extension, such request to be presented to us before the expiry of the Guarantee.

This Guarantee is subject to the Uniform Rules for Demand Guarantees, ICC Publication No. 458.

\_\_\_\_\_  
*[signature(s) of authorized representative(s) of the bank]*

<sup>3</sup> The issuing bank shall insert the amount(s) specified in the SCC and denominated, as specified in the SCC, either in the currency(ies) of the Contract or a freely convertible currency acceptable to the Procuring Entity.

<sup>4</sup> Insert the Delivery date stipulated in the Contract Delivery Schedule.

ސަލާމް ސަލާމް - 3: ބަލަވާ ސަލާމް ސަލާމް / ސަލާމް ސަލާމް ސަލާމް  
ސަލާމް ސަލާމް ސަލާމް ސަލާމް ސަލާމް ސަލާމް ސަލާމް ސަލާމް









අවම වශයෙන් 2000 ක් වැඩි විය යුතුය. එහි ප්‍රධාන අංගය වන (විදුලි බලාපොරොත්තු) වැඩි විය යුතුය.

**4. වැඩි විය යුතු ප්‍රධාන අංගය.**

- වැඩි විය යුතු ප්‍රධාන අංගය වන 5'x4 ක් වැඩි විය යුතුය. එහි ප්‍රධාන අංගය වන (විදුලි බලාපොරොත්තු) වැඩි විය යුතුය.
- වැඩි විය යුතු ප්‍රධාන අංගය වන 6 ක් වැඩි විය යුතුය. එහි ප්‍රධාන අංගය වන (විදුලි බලාපොරොත්තු) වැඩි විය යුතුය.

**ප්‍රධාන අංගය වන 8' x 6' ක් වැඩි විය යුතුය.**

- වැඩි විය යුතු ප්‍රධාන අංගය වන 8' x 6' ක් වැඩි විය යුතුය. එහි ප්‍රධාන අංගය වන (විදුලි බලාපොරොත්තු) වැඩි විය යුතුය.
- වැඩි විය යුතු ප්‍රධාන අංගය වන 12 ක් වැඩි විය යුතුය. එහි ප්‍රධාන අංගය වන (විදුලි බලාපොරොත්තු) වැඩි විය යුතුය.

**5. වැඩි විය යුතු ප්‍රධාන අංගය.**

- වැඩි විය යුතු ප්‍රධාන අංගය වන 100 ක් වැඩි විය යුතුය. එහි ප්‍රධාන අංගය වන (විදුලි බලාපොරොත්තු) වැඩි විය යුතුය.
- වැඩි විය යුතු ප්‍රධාන අංගය වන 4 ක් වැඩි විය යුතුය. එහි ප්‍රධාන අංගය වන (විදුලි බලාපොරොත්තු) වැඩි විය යුතුය.
- වැඩි විය යුතු ප්‍රධාන අංගය වන 12 ක් වැඩි විය යුතුය. එහි ප්‍රධාන අංගය වන (විදුලි බලාපොරොත්තු) වැඩි විය යුතුය.





16	68 ( 68 )	4 3	4 3
1	63	4	4
1	63	4	4
4	16		
7	10		
2	6		

.....  
.....

13	-	LED 24W))	.....
7	4	6	.....
1	0	2	.....

.....  
.....

.....

- ..... 2- .....  
.....







# ANNEX -1

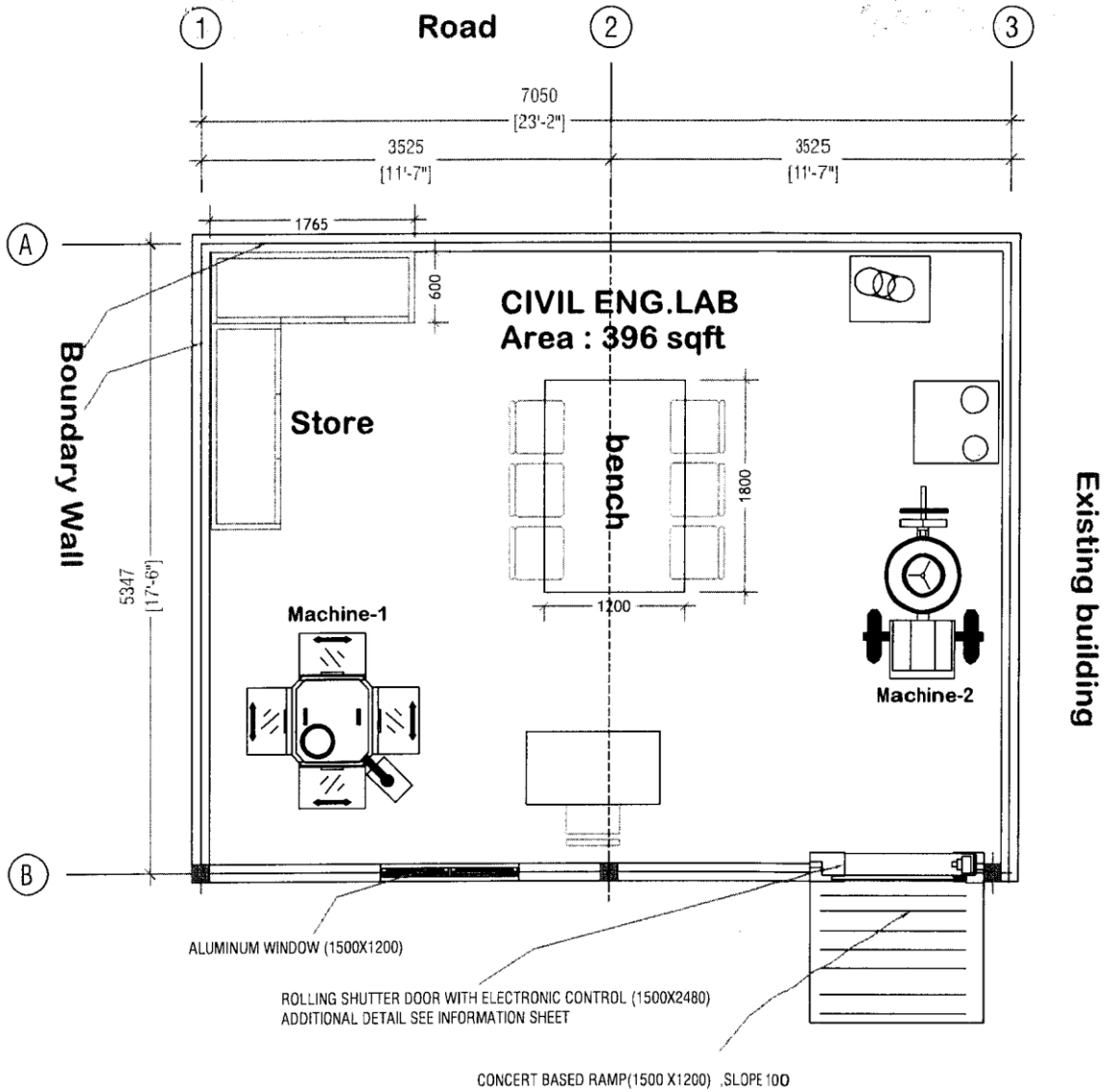

## FLOOR PLAN

SCALE 1: 100



Project Title

Date 01/08/2023

**FEST - CIVIL ENGINEERING MATERIAL TESTING LAB  
CONSTRUCTION IN CMS (VILI MALE ')**

MALDIVES NATIONAL UNIVERSITY

Facilities Management Section

Email: facilities\_management\_section@mnu.edu.mv

All dimensions are inclusive and must be confirmed at the site by the contractor.

Phone : 3345134

Contact : 3345192 / 3345134

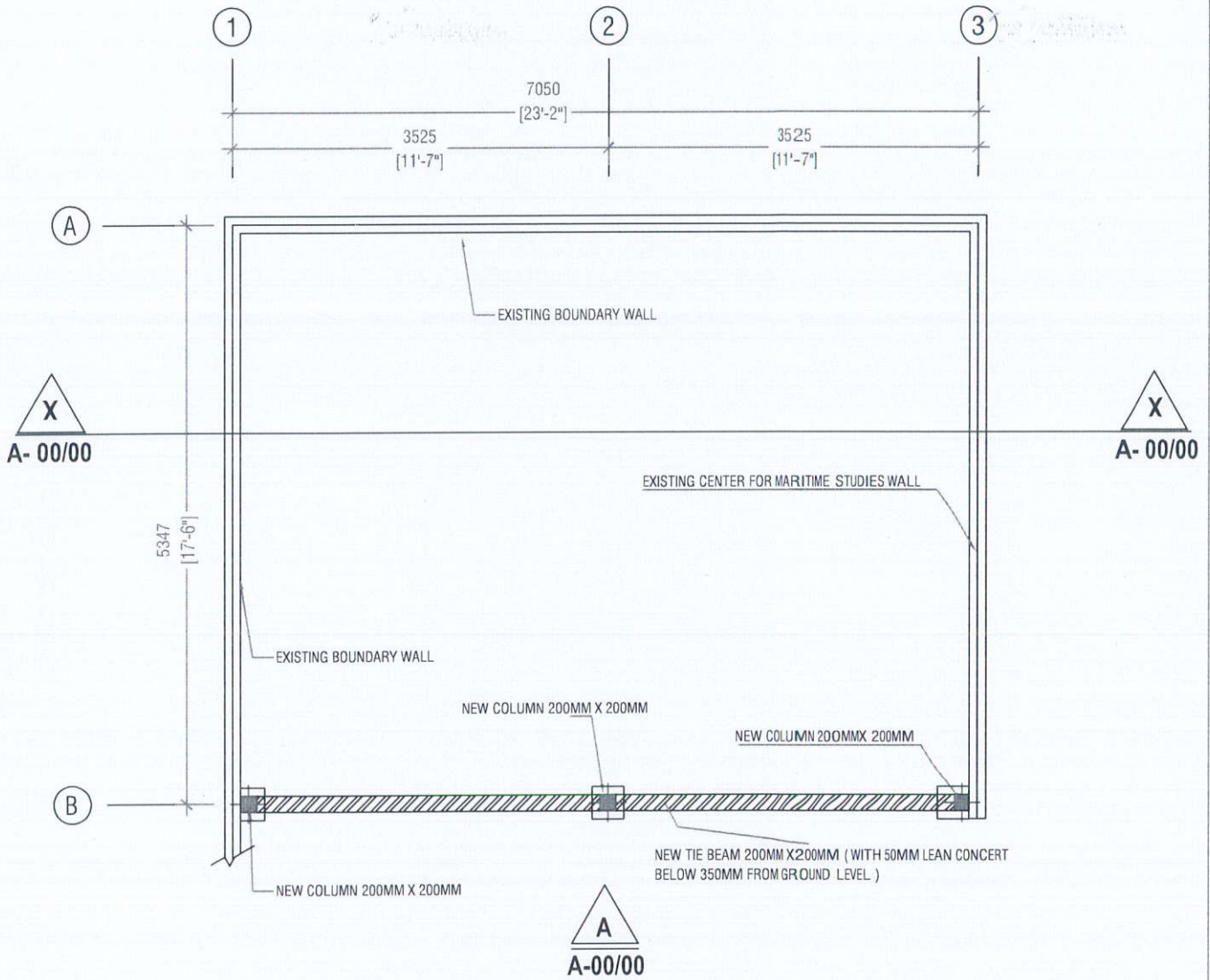

## BEAM AND COLUMN PLAN

SCALE 1: 100

Project Title

Date 01/08/2023

**FEST - CIVIL ENGINEERING MATERIAL TESTING LAB  
CONSTRUCTION IN CMS (VILI MALE ')**

MALDIVES NATIONAL UNIVERSITY

Facilities Management Section

Email: facilities.management.section@mnu.edu.mv

All dimensions are indicative, and must be confirmed at the site by the contractor.

Drawn : Sunain

Contact : 3345192 / 3345134



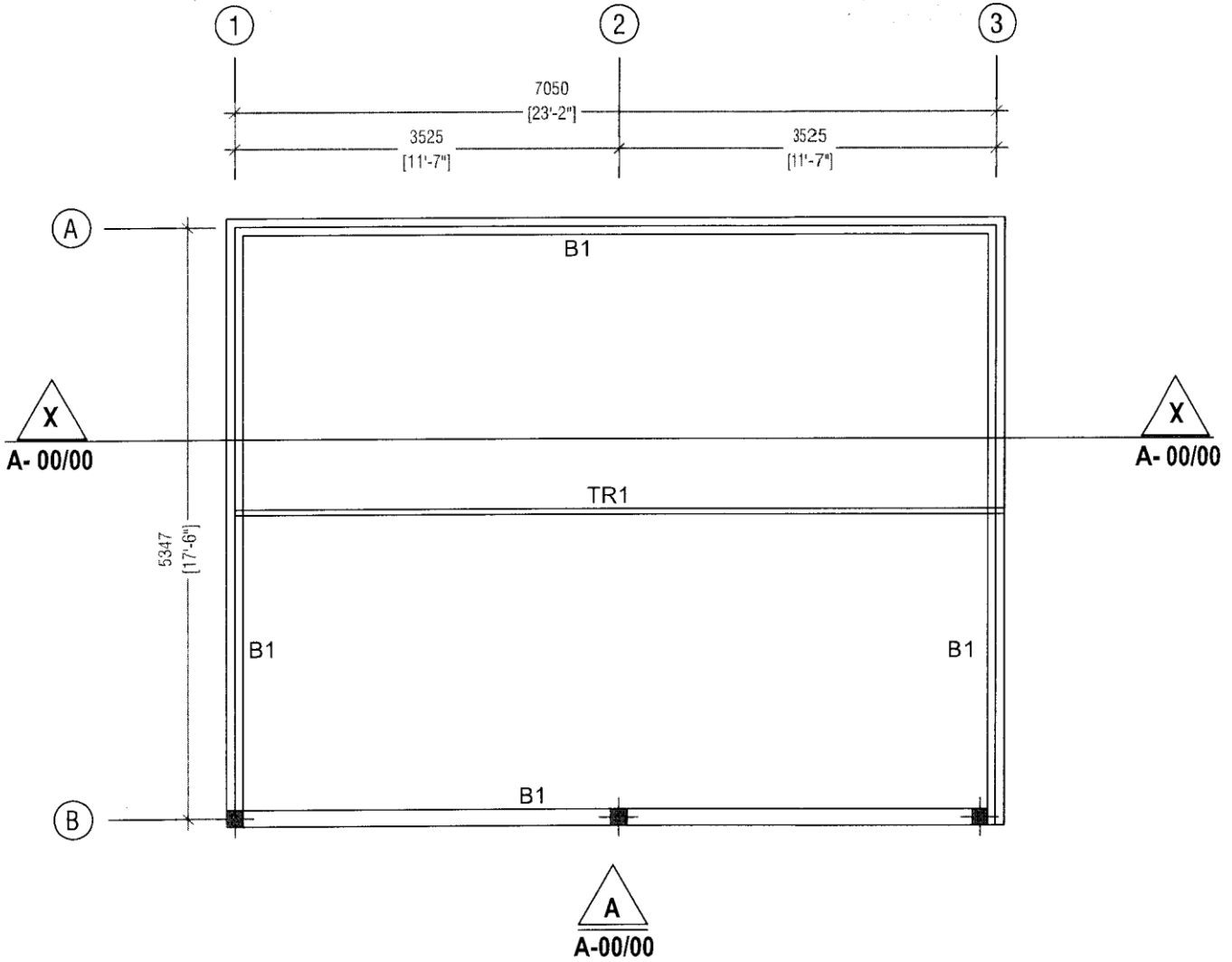

## ROOF TRUSS AND ROOF BEAM PLAN

SCALE 1: 100



Project Title

Date 01/08/2023

**FEST - CIVIL ENGINEERING MATERIAL TESTING LAB  
CONSTRUCTION IN CMS (VILI MALE')**

MALDIVES NATIONAL UNIVERSITY

Facilities Management Section

Email: facilities.management@mnun.edu.mv

All dimensions are indicative and must be confirmed at the site by the contractor.

Phone: 3345192

Mobile: 3345192 / 0045104

35x35 HOLLOW BOX TYPE GALVANIZE BATTENS @ 600 c/c

50x75 HOLLOW BOX TYPE GALVANIZE RAFTERS @ 800 c/c

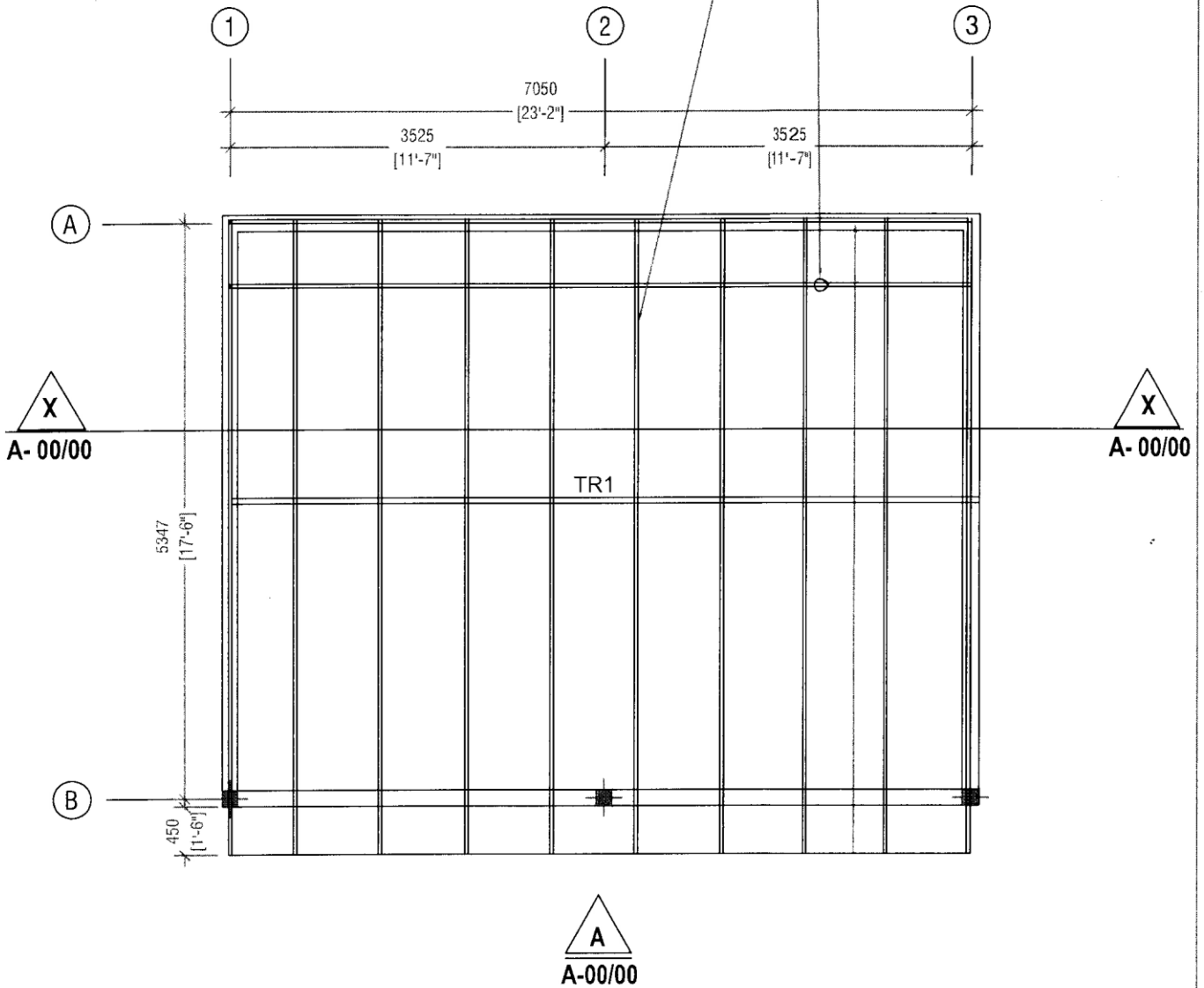

## ROOF FRAMING PLAN

SCALE 1: 100



Project Title

Date 01/08/2023

**FEST - CIVIL ENGINEERING MATERIAL TESTING LAB  
CONSTRUCTION IN CMS (VILI MALE ')**

MALDIVES NATIONAL UNIVERSITY

Facilities Management Section

Email: facilities.management.section@mnu.edu.mv

All dimensions are indicative and must be confirmed at the site by the contractor.

Drawn: S. S. S.

Contact: 3333 142 1340114

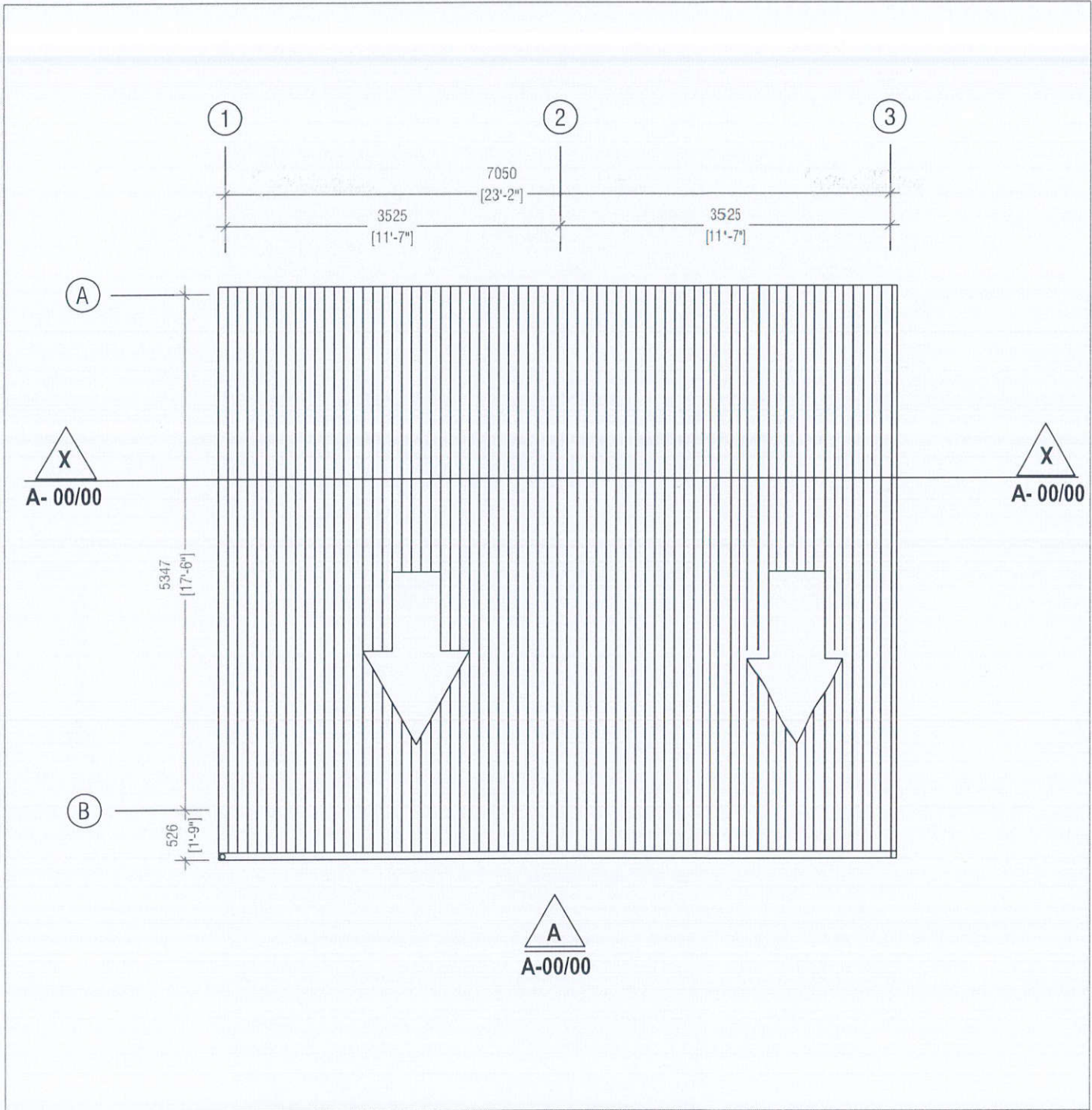

# ROOF PLAN

SCALE 1: 100



Project Title

Date 01/08/2023

**FEST - CIVIL ENGINEERING MATERIAL TESTING LAB  
CONSTRUCTION IN CMS (VILI MALE')**

MALDIVES NATIONAL UNIVERSITY  
Facilities Management Section

Email: facilities.management.section@mnu.edu.mv

Drawn : Sunaah

Contact : 3345192 / 3345134

All dimensions are indicative, and must be confirmed at the site by the contractor.

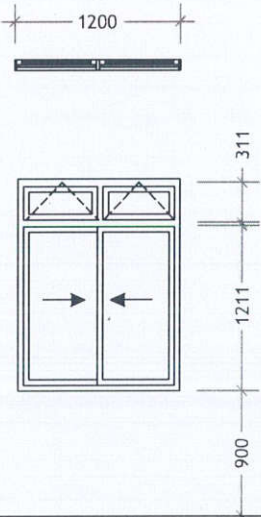
<p><b>Plans :</b></p> <p><b>Elevations :</b></p> <p><b>Finish Floor level</b></p>	 <p>Note : All the measurements to be checked at site by contractor before fabrication</p>
<p><b>Doors &amp; Windows no :</b></p>	
<p><b>Frame :</b></p>	<p><i>Aluminium framed Sliding Door Panel with glazed Top Hung panels</i></p>
<p><b>Doors &amp; Windows Size :</b></p>	<p><i>25 Micron White Anodised Aluminium frame</i></p>
<p><b>Hardware :</b></p>	<p><i>02 nos. Aluminium framed sliding windows 02 nos. Aluminium framed glazed openable Top hung panels 04 nos. Hinges 02 nos. Lock handles 01 no. Crescent Lock</i></p>
<p><b>Glazing :</b></p>	<p><i>6mm thick Black tinted glass</i></p>

## WINDOWS

Scale 1:50

Project Title

Date 01/08/2023

**FEST - CIVIL ENGINEERING MATERIAL TESTING LAB  
CONSTRUCTION IN CMS (VILI MALE ')**

MALDIVES NATIONAL UNIVERSITY

Facilities Management Section

Email: facilities.management.section@minu.edu.mv

All dimensions are indicative, and must be confirmed at the site by the contractor.

Drawn : Sunaari

Contact : 3345192 / 3345134



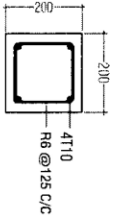

**COLUMN DETAIL**

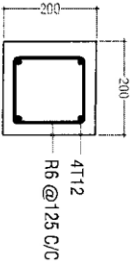

**TIE BEAM DETAIL**

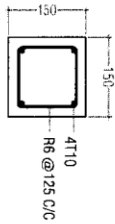

**ROOF BEAM DETAIL**

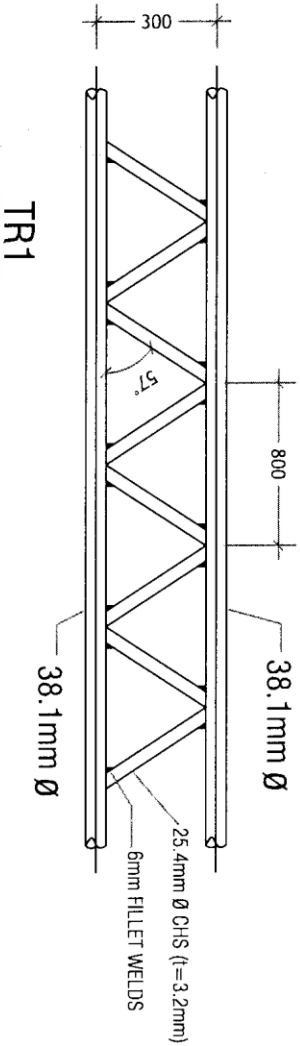

**COLUMN STUMP CONNECTION DETAIL**

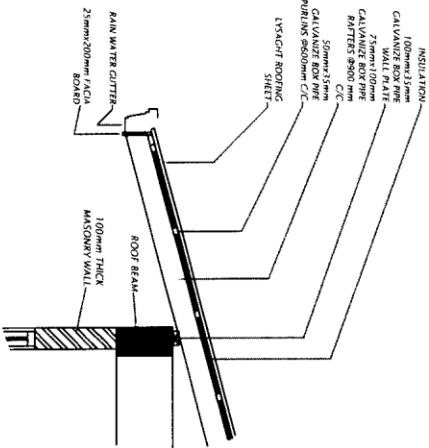
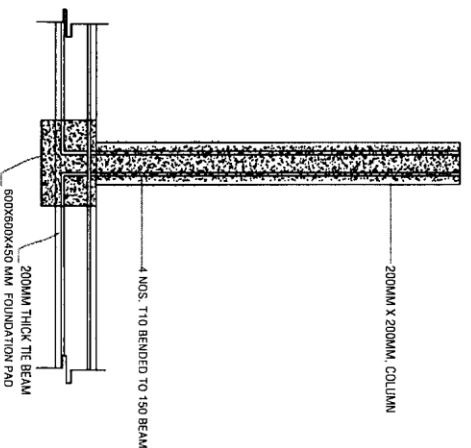

**DETAIL DRAWING**

Scale 1:50

Project Title

Date 01/08/2023

**FEST - CIVIL ENGINEERING MATERIAL TESTING LAB  
CONSTRUCTION IN CMS (VILI MALE')**

MALDIVES NATIONAL UNIVERSITY

Facilities Management Section

Email: facilities.management.section@mun.edu.mv  
All dimensions are indicative, and must be confirmed at the site by the contractor.

Drawn: S. M. M. M.  
Contact: 3445142 / 3445134





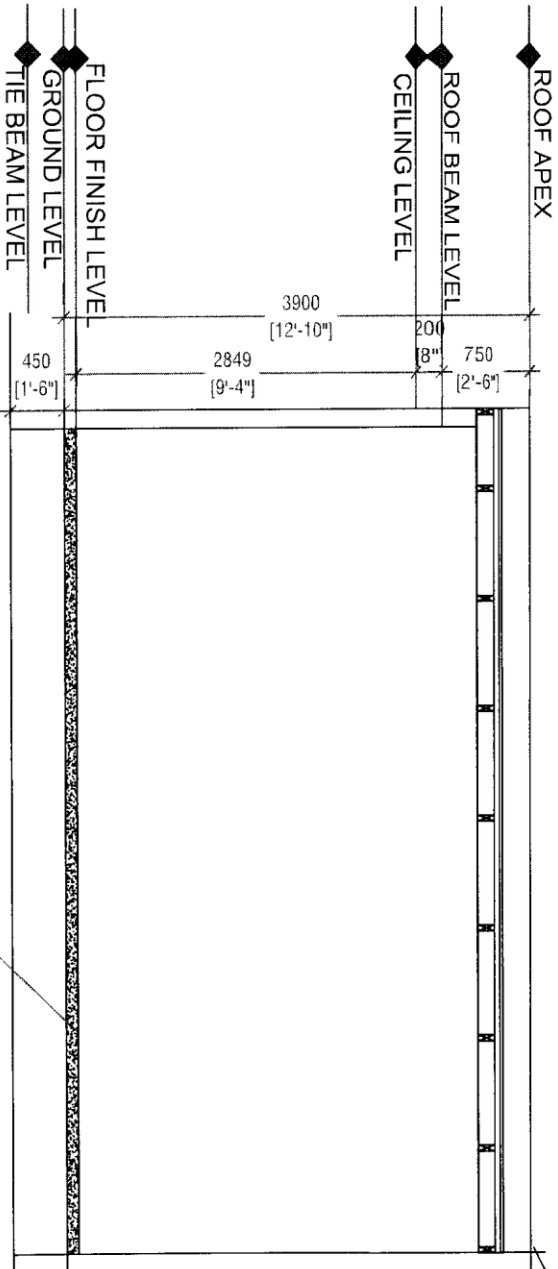

# SECTION X-X

SCALE 1:100

Project Title

Date 01/08/2023

**FEST - CIVIL ENGINEERING MATERIAL TESTING LAB  
CONSTRUCTION IN CMS (VILI MALE')**

MALDIVES NATIONAL UNIVERSITY

Facilities Management Section

Engr. Hafithes Muthaariyah (hmf@nu.edu.mv)  
All dimensions are in millimeters and must be confirmed at the site by the contractor.

Phone: +960 333 1111

Corner: GOLFERS ROAD, MALE

Website: www.nu.edu.mv



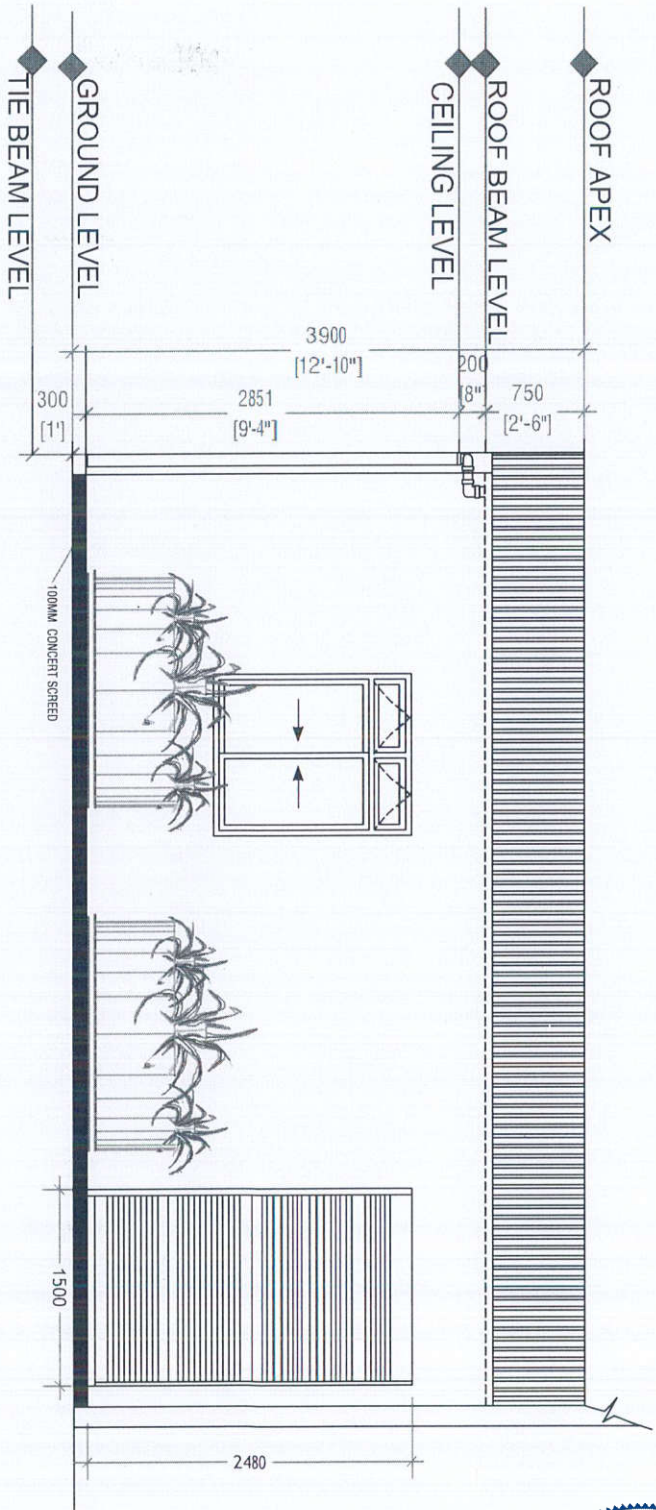

# ELEVATION -A

SCALE 1:100

Project Title

Date 01/08/2023

**FEST - CIVIL ENGINEERING MATERIAL TESTING LAB  
CONSTRUCTION IN CMS (VILI MALE')**

MALDIVES NATIONAL UNIVERSITY

Facilities Management Section

Email: facilities\_management\_section@mnu.edu.mv  
All dimensions are indicative, and must be confirmed at the site by the contractor.



Drawn: Surinath  
Contact: 3845192 / 3345134

TOP VIEW

Curing Tank

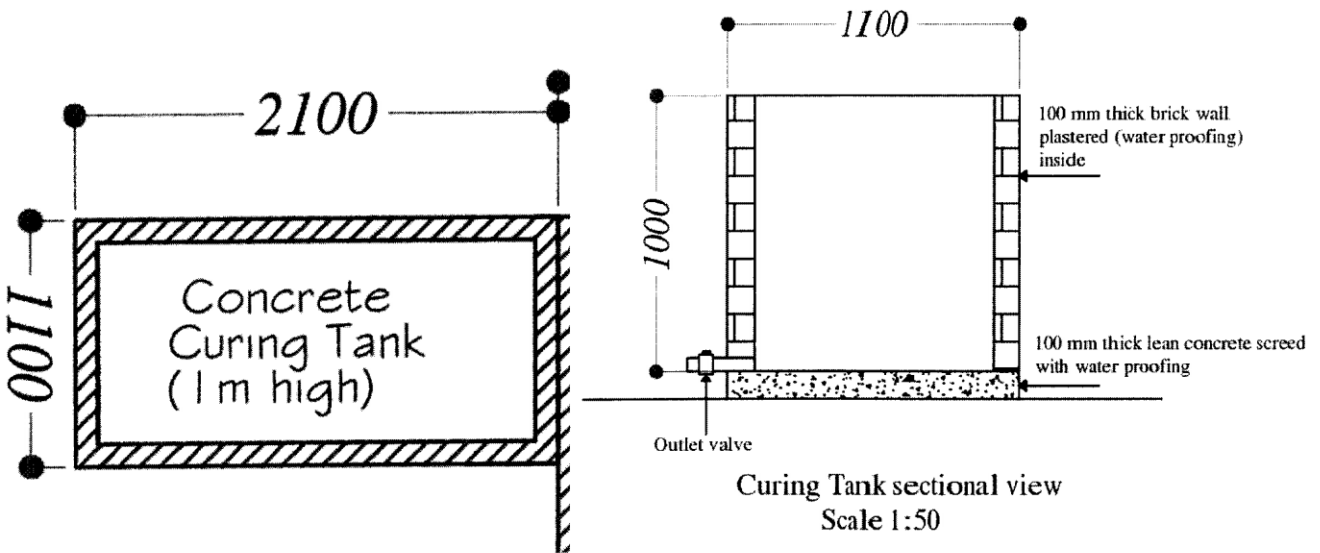

ދިވެހިރާއްޖޭގެ ޖުމްހޫރިއްޔާ ގުޅިގެން

(1) ދިވެހިރާއްޖޭގެ ޖުމްހޫރިއްޔާ ގުޅިގެން ސަރުކާރުގެ ފަރާތުން ޖަހާލެވިފައިވާ ޕްލާން ޕްރޮޖެކްޓް ގެ ދަށުން ޖެނަރޭލް ޕްލާނެއް ޖަހާލެވިފައިވާ ގޮތުން ސަރުކާރުގެ ފަރާތުން ޖަހާލެވިފައިވާ ޕްލާން ޕްރޮޖެކްޓް ގެ ދަށުން ޖެނަރޭލް ޕްލާނެއް ޖަހާލެވިފައިވާ ގޮތުން

ސަރުކާރުގެ ފަރާތުން ޖަހާލެވިފައިވާ ޕްލާން ޕްރޮޖެކްޓް ގެ ދަށުން ޖެނަރޭލް ޕްލާނެއް ޖަހާލެވިފައިވާ ގޮތުން ސަރުކާރުގެ ފަރާތުން ޖަހާލެވިފައިވާ ޕްލާން ޕްރޮޖެކްޓް ގެ ދަށުން ޖެނަރޭލް ޕްލާނެއް ޖަހާލެވިފައިވާ ގޮތުން ސަރުކާރުގެ ފަރާތުން ޖަހާލެވިފައިވާ ޕްލާން ޕްރޮޖެކްޓް ގެ ދަށުން ޖެނަރޭލް ޕްލާނެއް ޖަހާލެވިފައިވާ ގޮތުން



# ANNEX -2

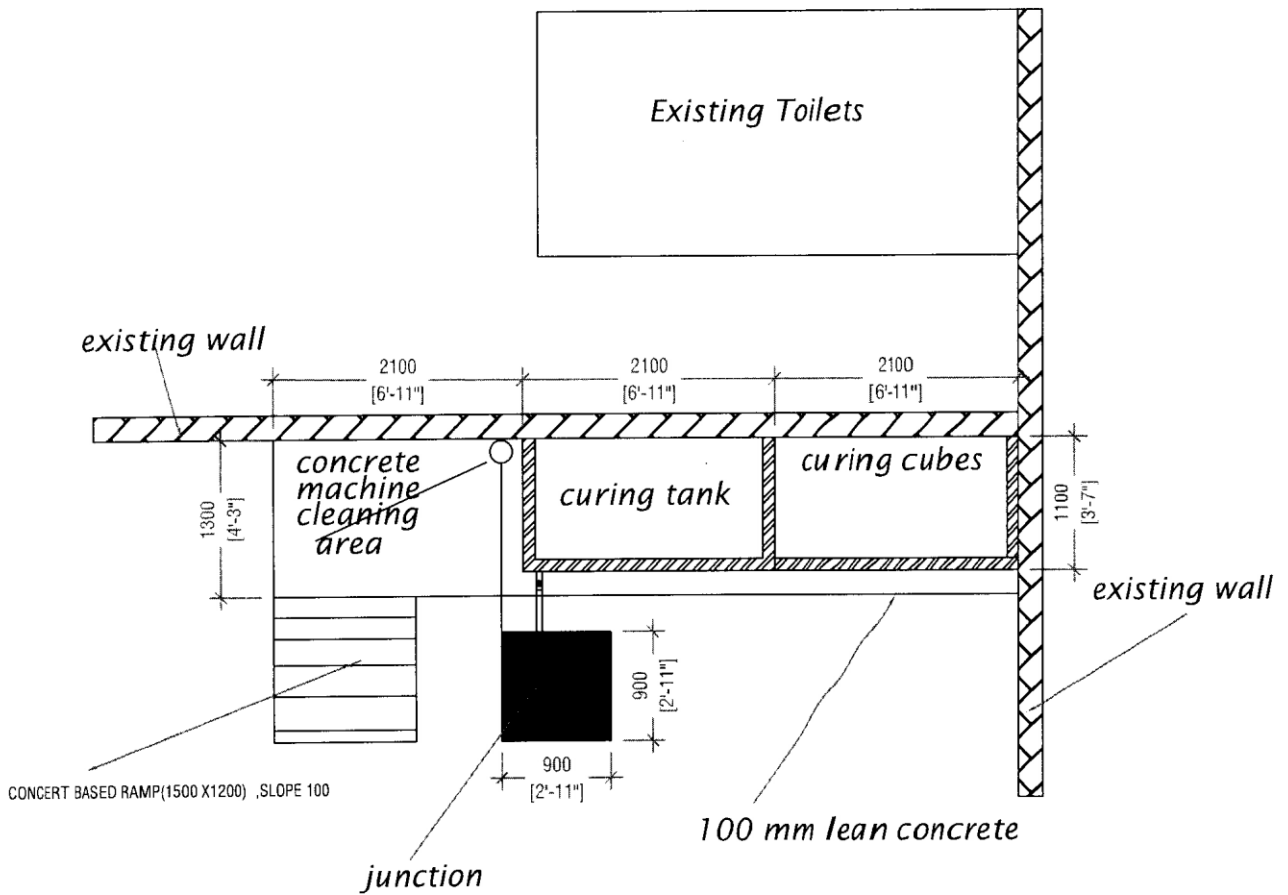

Project Title

Date 01/08/2023

## FEST - CIVIL ENGINEERING MATERIAL TESTING LAB CONSTRUCTION IN CMS (VILI MALE ')



MALDIVES NATIONAL UNIVERSITY  
Facilities Management Section

Email: facilities\_management\_section@mnu.edu.mv  
All dimensions are indicative, and must be confirmed at the site by the contractor.

Drawn: Sanaath  
Contact: 3345192 / 3345134

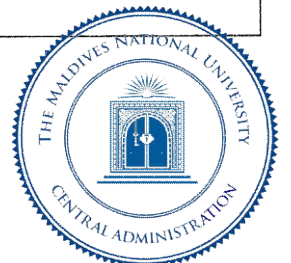

**ސުވާލު 100 ގެ ލިސްޓު ގައި ހިމެނޭ ސުވާލުތަކުގެ ތެރޭގައި ހިމެނޭ ސުވާލުތައް**

<b>ސުވާލު 100 ގެ ލިސްޓު ގައި ހިމެނޭ ސުވާލުތަކުގެ ތެރޭގައި ހިމެނޭ ސުވާލުތައް</b>	
80	<ul style="list-style-type: none"> <li>• ސުވާލު 80 (އަދި 80 ގެ ތެރޭގައި ހިމެނޭ ސުވާލުތަކުގެ ތެރޭގައި ހިމެނޭ ސުވާލުތައް)</li> </ul>
20	<ul style="list-style-type: none"> <li>• ސުވާލު 20 (އަދި 20 ގެ ތެރޭގައި ހިމެނޭ ސުވާލުތަކުގެ ތެރޭގައި ހިމެނޭ ސުވާލުތައް)</li> </ul>
100	<b>މުއްދަ</b>

