



Email: [info.idearch@gmail.com](mailto:info.idearch@gmail.com)  
Contact: 7604174 / 9905543

# **PROPOSED SINGLE STOREY BEACH HUT**

**G.A.KONDEY- MALDIVES**

**CLIENT: G.A. KONDEY COUNCIL**

**ARCHITECTURAL, STRUCTURAL AND SERVICES DRAWINGS**

CLIENT:

G.A. KONDEY COUNCIL

PROJECT:

BEACH HUT 1

G.A. KONDEY

ARCHITECT:

AHUSAN ABDUL MUHUSIN

ENGINEER:

MOHAMED AHMEEM

SCALE: AS GIVEN

DRWNG TITLE : AS GIVEN

DATE: D07M09Y23

REVISION NO.: 00

FILE NAME:

\\IDEARCH\2023\PROJECTS\COMMERCIAL\BEACH HUT 1

WARNING:

- This drawing shall not be used for construction unless certified.
- Contractor to verify all dimensions of existing works on site before commencing any work or preparing shop drawings.
- Do not scale drawings, use written dimensions only.
- This drawing is to be read in conjunction with the specifications and conditions of contract.
- This drawing and design is copyright and no portion may be reproduced without the permission of the ideArch designs.

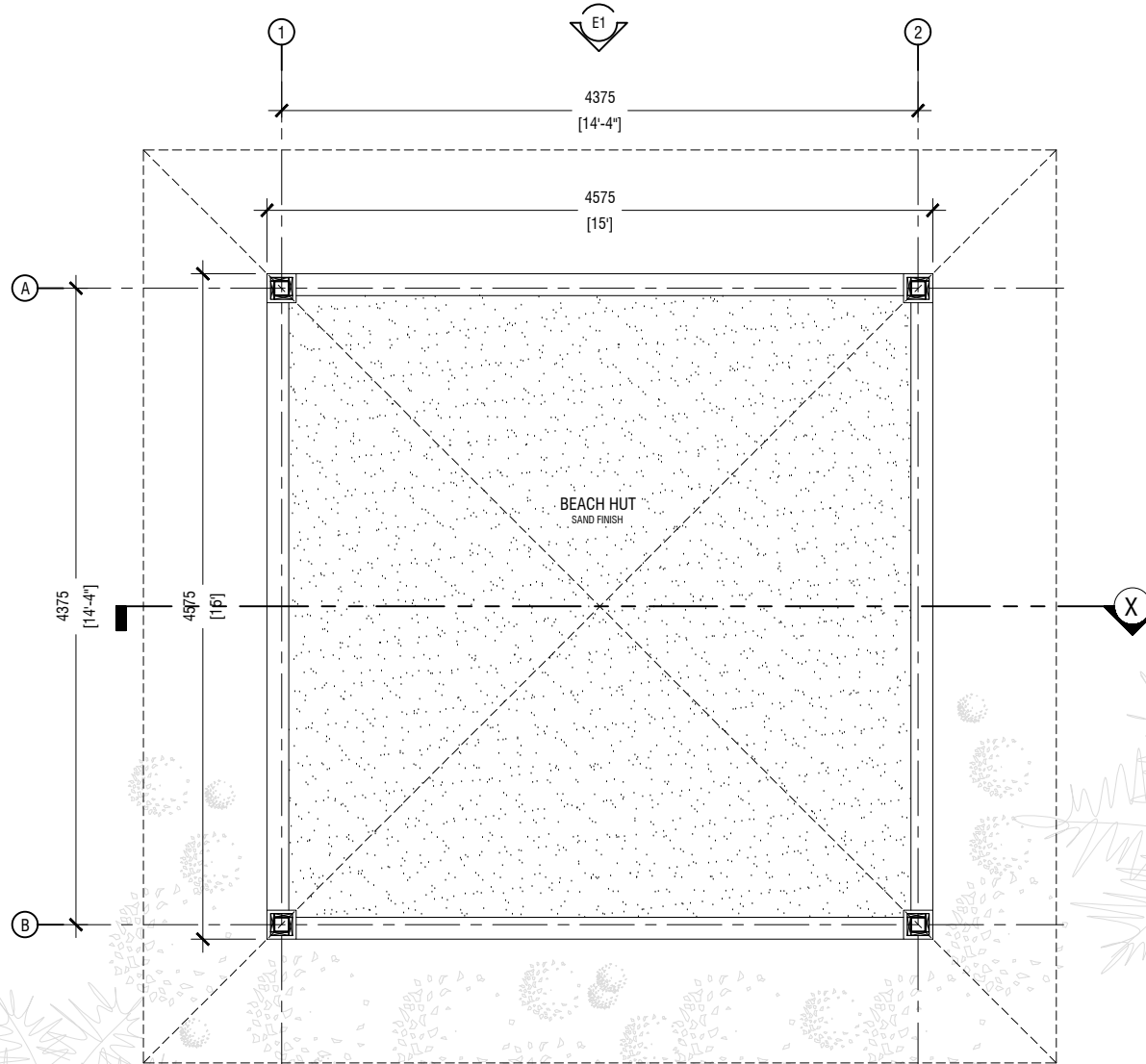

NOTE:  
ALL EXPOSED STEEL STRUCTURES TO BE COVERED WITH TIMBER CLADDING

BEACH HUT FLOOR PLAN

SCALE = 1:50

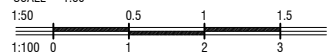

A01

CLIENT:  
G.A. KONDEY COUNCIL

PROJECT:  
**BEACH HUT 1**  
G.A. KONDEY

ARCHITECT:  
AHUSAN ABDUL MUHUSIN

ENGINEER:  
MOHAMED AHMEEM

SCALE: AS GIVEN

DRWNG TITLE : AS GIVEN

DATE: D07M09Y23

REVISION NO.: 00

FILE NAME:  
//IDEARCH/2023/PROJECTS/COMMERCIAL/  
BEACH HUT 1

**WARNING:**  
- This drawing shall not be used for construction unless certified.  
- Contractor to verify all dimensions of existing works on site before commencing any work or preparing shop drawings.  
- Do not scale drawings, use written dimensions only.  
- This drawing is to be read in conjunction with the specifications and conditions of contract.  
- This drawing and design is copyright and no portion may be reproduced without the permission of the ideArch designs.

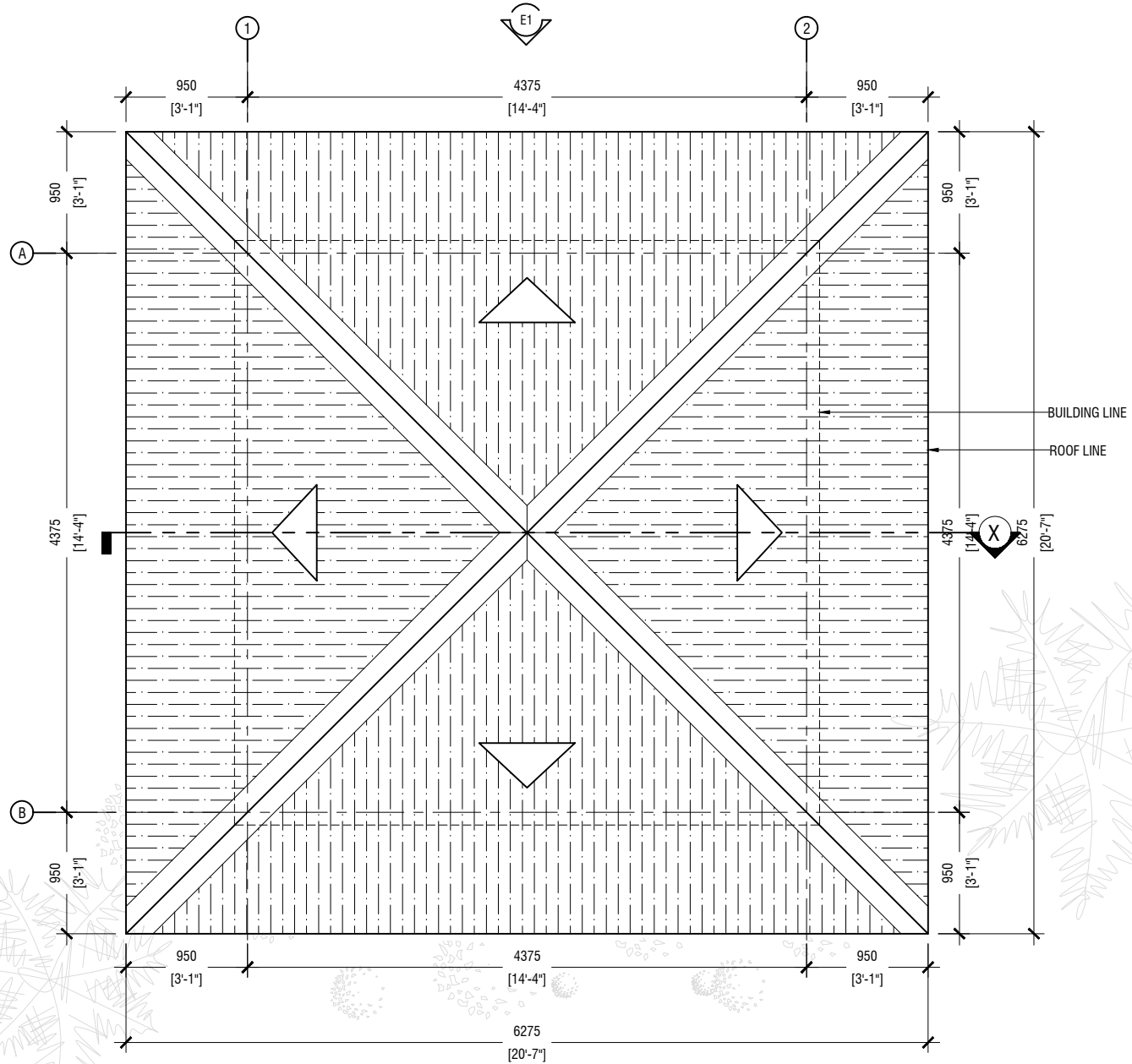

ROOF PLAN

SCALE = 1:50

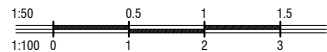

**A02**

CLIENT:  
G.A. KONDEY COUNCIL

PROJECT:  
**BEACH HUT 1**  
G.A. KONDEY

ARCHITECT:  
AHUSAN ABDUL MUHUSIN

ENGINEER:  
MOHAMED AHMEEM

SCALE: AS GIVEN

DRWNG TITLE : AS GIVEN

DATE: D07M09Y23

REVISION NO.: 00

FILE NAME:  
//IDEARCH/2023/PROJECTS/COMMERCIAL/  
BEACH HUT 1

**WARNING:**  
 - This drawing shall not be used for construction unless certified.  
 - Contractor to verify all dimensions of existing works on site before commencing any work or preparing shop drawings.  
 - Do not scale drawings, use written dimensions only.  
 - This drawing is to be read in conjunction with the specifications and conditions of contract.  
 - This drawing and design is copyright and no portion may be reproduced without the permission of the ideArch designs.

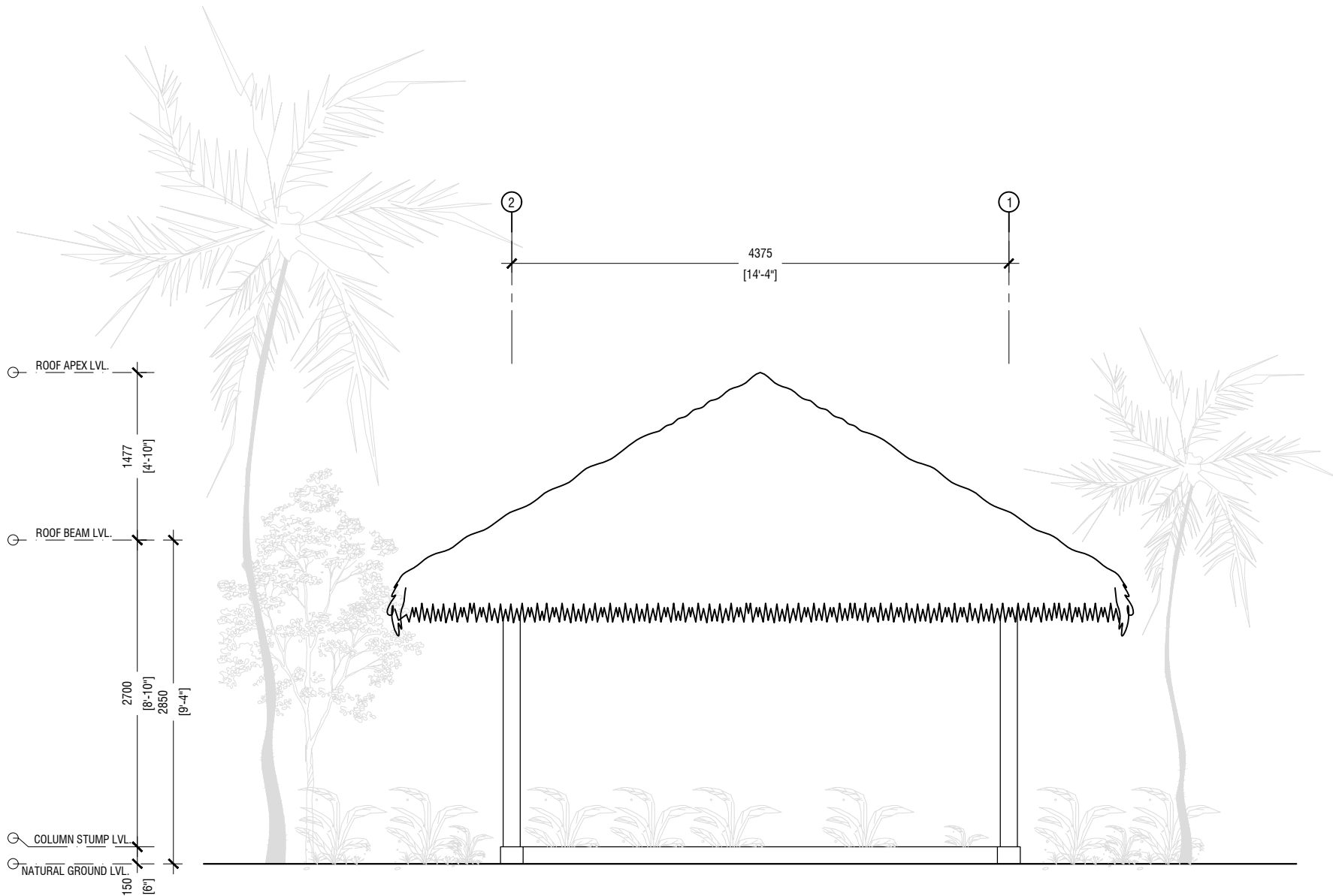

ELEVATION E1

SCALE = 1:50

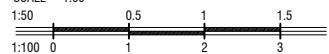

**A03**

CLIENT:  
G.A. KONDEY COUNCIL

PROJECT:  
**BEACH HUT 1**  
G.A. KONDEY

ARCHITECT:  
AHUSAN ABDUL MUHUSIN

ENGINEER:  
MOHAMED AHMEEM

SCALE: AS GIVEN

DRWNG TITLE : AS GIVEN

DATE: D07M09Y23

REVISION NO.: 00

FILE NAME:  
//IDEARCH/2023/PROJECTS/COMMERCIAL/  
BEACH HUT 1

**WARNING:**  
 - This drawing shall not be used for construction unless certified.  
 - Contractor to verify all dimensions of existing works on site before commencing any work or preparing shop drawings.  
 - Do not scale drawings, use written dimensions only.  
 - This drawing is to be read in conjunction with the specifications and conditions of contract.  
 - This drawing and design is copyright and no portion may be reproduced without the permission of the ideArch designs.

**A04**

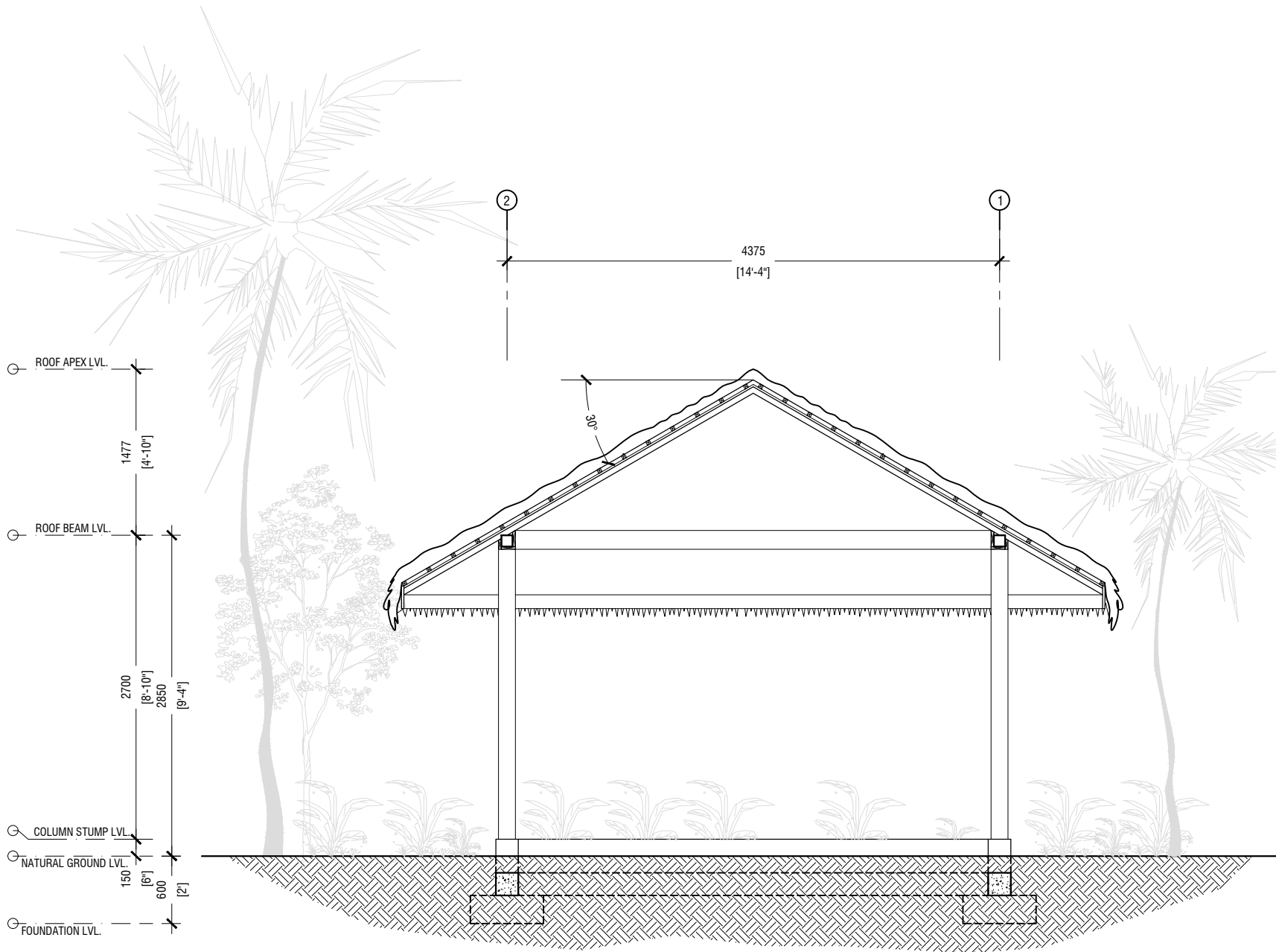

**SECTION X-X**

SCALE = 1:50

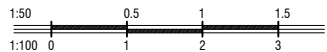

CLIENT:  
G.A. KONDEY COUNCIL

PROJECT:  
**BEACH HUT 1**  
G.A. KONDEY

ARCHITECT:  
AHUSAN ABDUL MUHUSIN

ENGINEER:  
MOHAMED AHMEEM

SCALE: AS GIVEN

DRWNG TITLE : AS GIVEN

DATE: D07M09Y23

REVISION NO.: 00

FILE NAME:  
//IDEARCH/2023/PROJECTS/COMMERCIAL/  
BEACH HUT 1

**WARNING:**  
- This drawing shall not be used for construction unless certified.  
- Contractor to verify all dimensions of existing works on site before commencing any work or preparing shop drawings.  
- Do not scale drawings, use written dimensions only.  
- This drawing is to be read in conjunction with the specifications and conditions of contract.  
- This drawing and design is copyright and no portion may be reproduced without the permission of the ideArch designs.

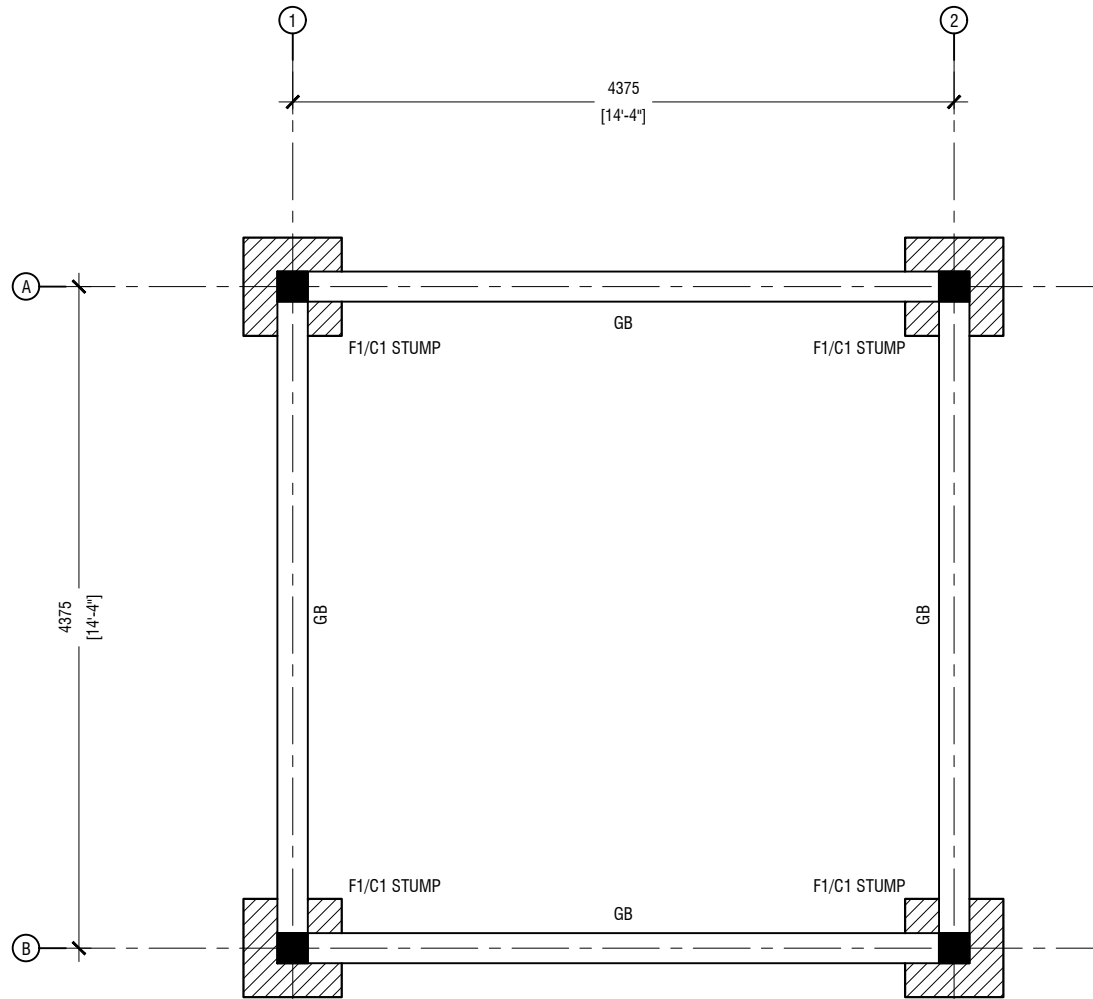

NOTE:  
F1 = 650X650X250 (T10@70 BOT. B/W)

COVER = 50mm

C1 COLUMN STUMP = 200x200mm (4T16, R6@150 C/C), UPTO + 150MM ABOVE GROUND LVL)

ALL FOUNDATION BEAMS ARE (GB)

FOUNDATION DEPTH = 600MM

**FOUNDATION PLAN**

SCALE = 1:50

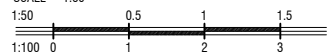

**S01**

CLIENT:  
G.A. KONDEY COUNCIL

PROJECT:  
**BEACH HUT 1**  
G.A. KONDEY

ARCHITECT:  
AHUSAN ABDUL MUHUSIN

ENGINEER:  
MOHAMED AHMEEM

SCALE: AS GIVEN

DRWNG TITLE : AS GIVEN

DATE: D07M09Y23

REVISION NO.: 00

FILE NAME:  
//IDEARCH/2023/PROJECTS/COMMERCIAL/  
BEACH HUT 1

**WARNING:**  
- This drawing shall not be used for construction unless certified.  
- Contractor to verify all dimensions of existing works on site before commencing any work or preparing shop drawings.  
- Do not scale drawings, use written dimensions only.  
- This drawing is to be read in conjunction with the specifications and conditions of contract.  
- This drawing and design is copyright and no portion may be reproduced without the permission of the ideArch designs.

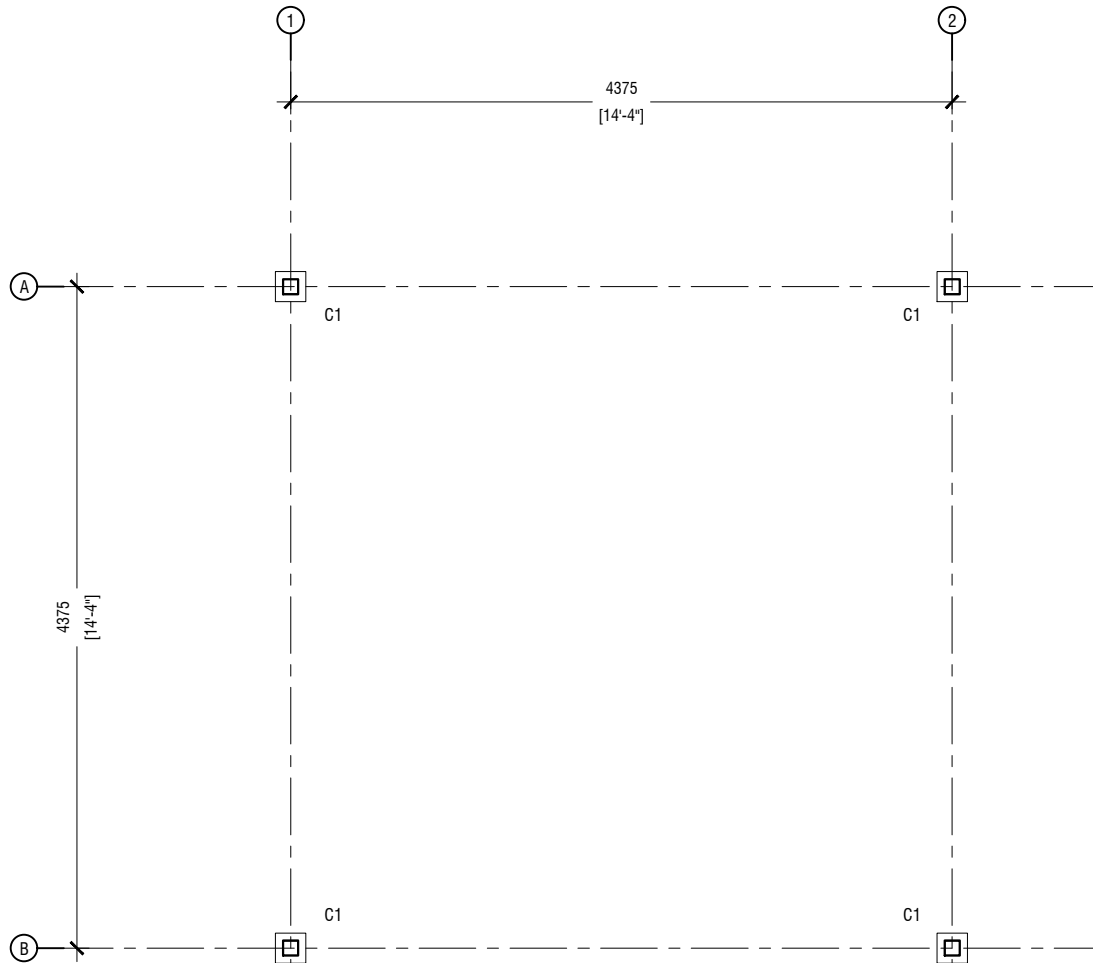

NOTE:

C1 COLUMN STUMP= 200x200mm (4T16, R6@150 C/C), UPTO +150MM ABOVE GROUND LVL

COVER=40mm

C1 = 100x100 x 3.6mm SHS (1NOS)

**COLUMN LOCATION PLAN**

SCALE = 1:50

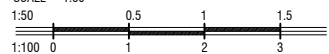

**S02**

CLIENT:

G.A. KONDEY COUNCIL

PROJECT:

BEACH HUT 1

G.A. KONDEY

ARCHITECT:

AHUSAN ABDUL MUHUSIN

ENGINEER:

MOHAMED AHMEEM

SCALE: AS GIVEN

DRWNG TITLE : AS GIVEN

DATE: D07M09Y23

REVISION NO.: 00

FILE NAME:

///IDEARCH/2023/PROJECTS/COMMERCIAL/  
BEACH HUT 1

WARNING:

- This drawing shall not be used for construction unless certified.
- Contractor to verify all dimensions of existing works on site before commencing any work or preparing shop drawings.
- Do not scale drawings, use written dimensions only.
- This drawing is to be read in conjunction with the specifications and conditions of contract.
- This drawing and design is copyright and no portion may be reproduced without the permission of the ideArch designs.

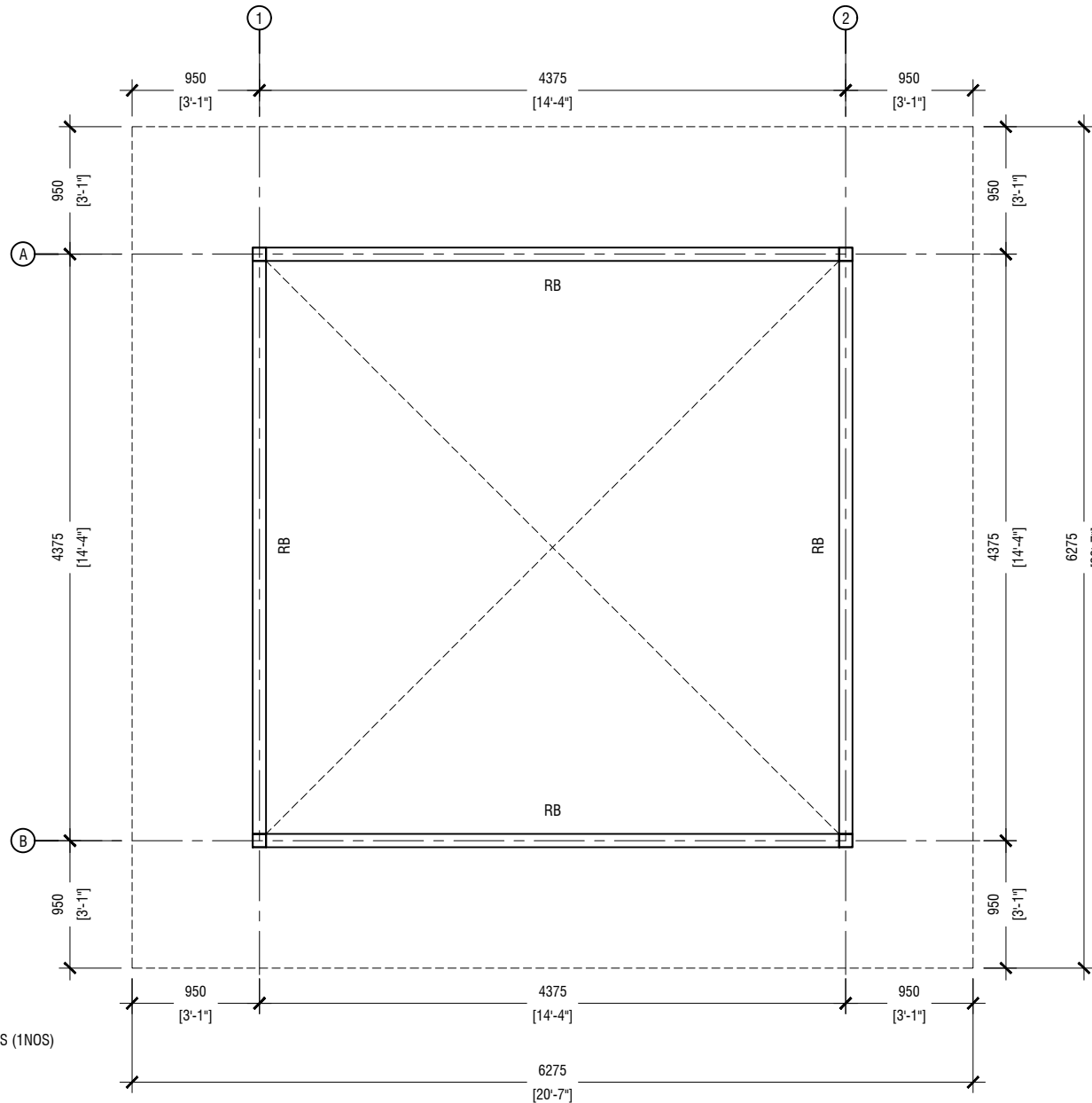

NOTE:

RB= 100x100 x 3.6mm SHS (1NOS)

ROOF BEAM PLAN

SCALE = 1:50

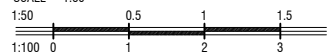

S03



CLIENT:

G.A. KONDEY COUNCIL

PROJECT:

BEACH HUT 1

G.A. KONDEY

ARCHITECT:

AHUSAN ABDUL MUHUSIN

ENGINEER:

MOHAMED AHMEEM

SCALE: AS GIVEN

DRWNG TITLE : AS GIVEN

DATE: D07M09Y23

REVISION NO.: 00

FILE NAME:

///IDEARCH/2023/PROJECTS/COMMERCIAL/  
BEACH HUT 1

WARNING:

- This drawing shall not be used for construction unless certified.
- Contractor to verify all dimensions of existing works on site before commencing any work or preparing shop drawings.
- Do not scale drawings, use written dimensions only.
- This drawing is to be read in conjunction with the specifications and conditions of contract.
- This drawing and design is copyright and no portion may be reproduced without the permission of the ideArch designs.

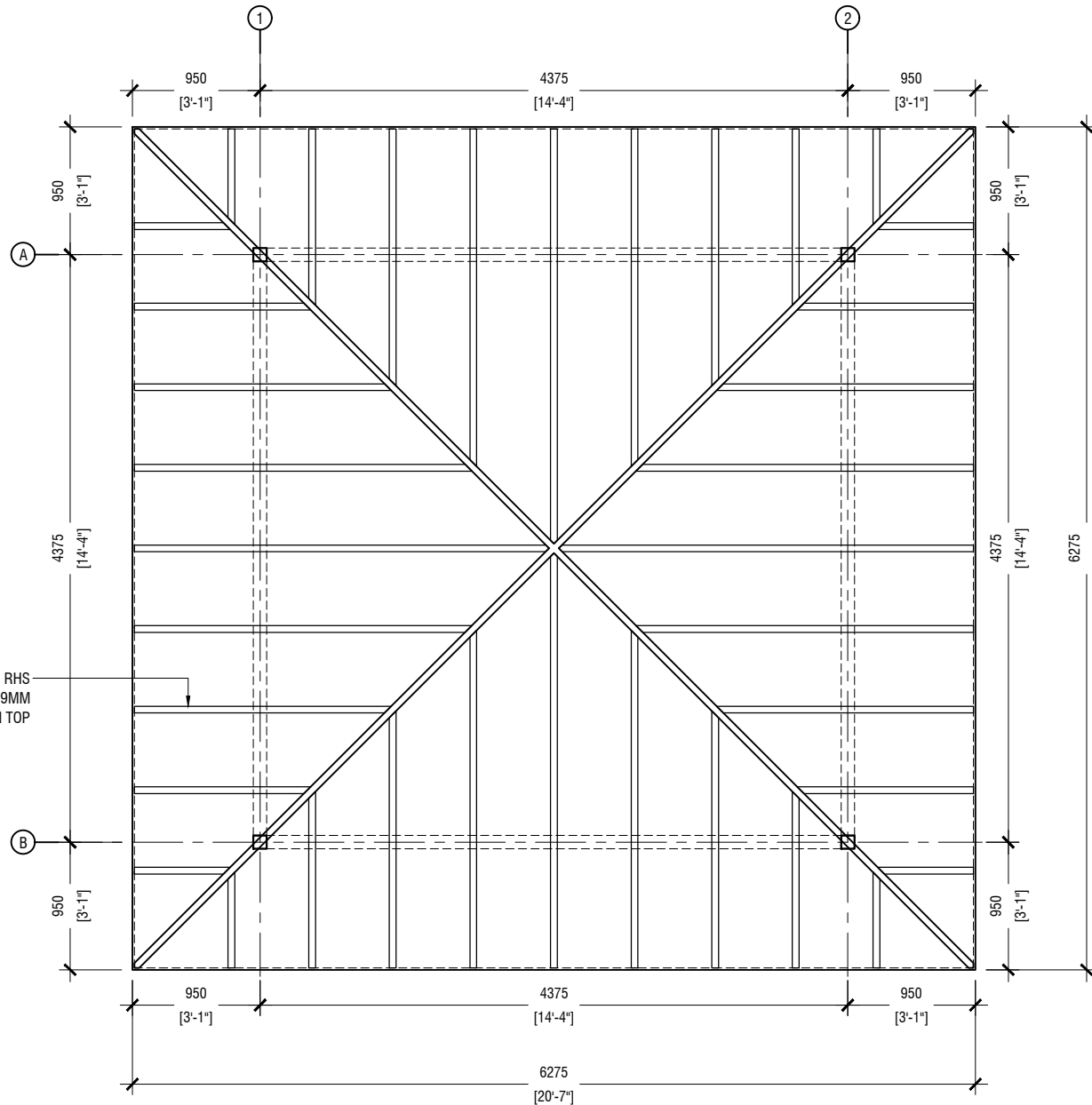

ROOF FRAMING PLAN 1

SCALE = 1:50

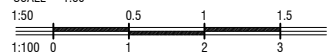

S04

CLIENT:  
G.A. KONDEY COUNCIL

PROJECT:  
**BEACH HUT 1**  
G.A. KONDEY

ARCHITECT:  
AHUSAN ABDUL MUHUSIN

ENGINEER:  
MOHAMED AHMEEM

SCALE: AS GIVEN

DRWNG TITLE : AS GIVEN

DATE: D07M09Y23

REVISION NO.: 00

FILE NAME:  
//IDEARCH/2023/PROJECTS/COMMERCIAL/  
BEACH HUT 1

**WARNING:**  
- This drawing shall not be used for construction unless certified.  
- Contractor to verify all dimensions of existing works on site before commencing any work or preparing shop drawings.  
- Do not scale drawings, use written dimensions only.  
- This drawing is to be read in conjunction with the specifications and conditions of contract.  
- This drawing and design is copyright and no portion may be reproduced without the permission of the ideArch designs.

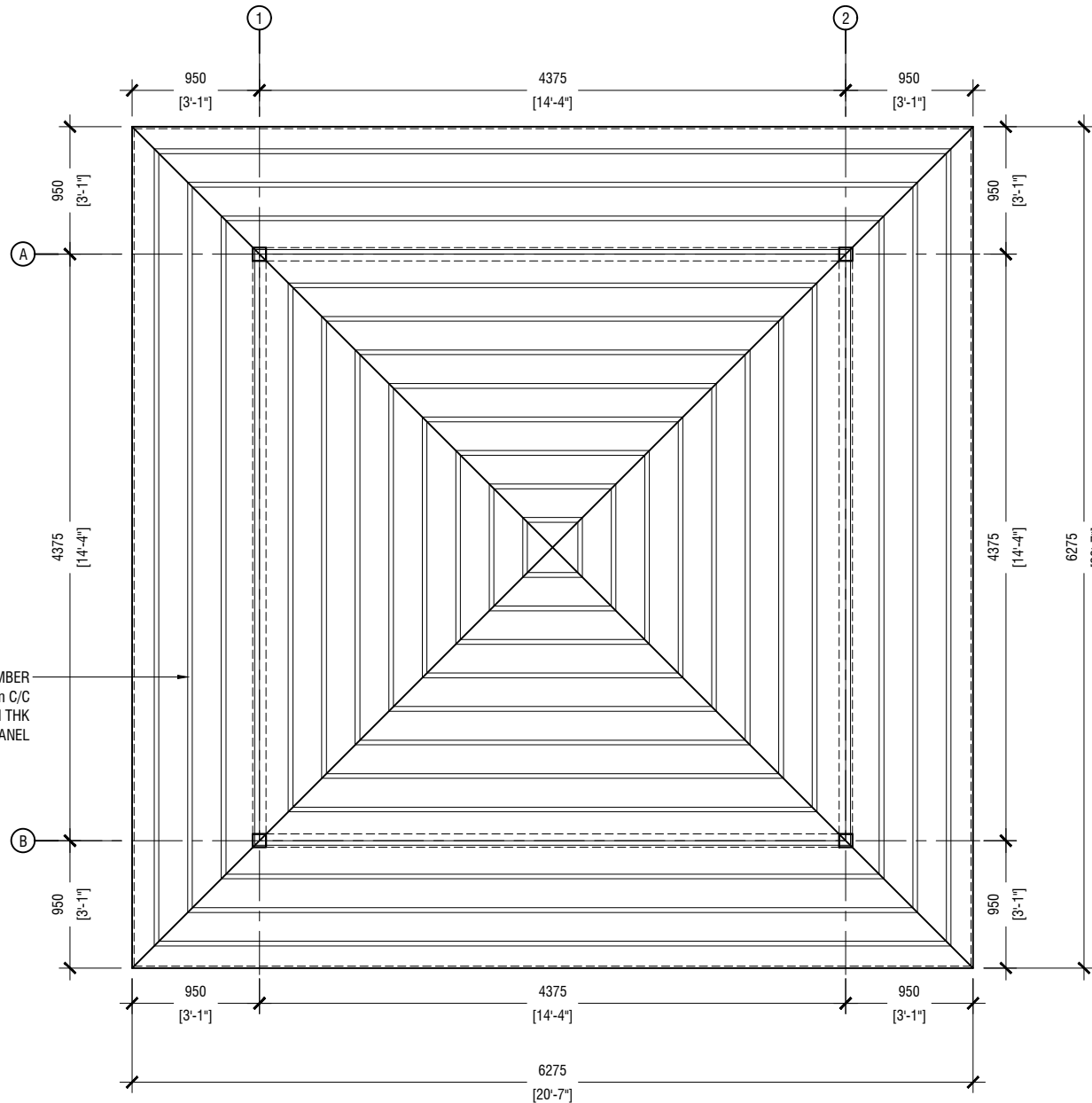

ROOF FRAMING PLAN 2

SCALE = 1:50

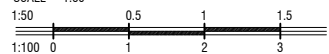

S05

CLIENT:  
**G.A. KONDEY COUNCIL**

PROJECT:  
**BEACH HUT 1**  
**G.A. KONDEY**

ARCHITECT:  
**AHUSAN ABDUL MUHUSIN**

ENGINEER:  
**MOHAMED AHMEEM**

SCALE: AS GIVEN

DRWNG TITLE : AS GIVEN

DATE: D07M09Y23

REVISION NO.: 00

FILE NAME:  
//IDEARCH/2023/PROJECTS/COMMERCIAL/  
BEACH HUT 1

WARNING:  
- This drawing shall not be used for construction unless certified.  
- Contractor to verify all dimensions of existing works on site before commencing any work or preparing shop drawings.  
- Do not scale drawings, use written dimensions only.  
- This drawing is to be read in conjunction with the specifications and conditions of contract.  
- This drawing and design is copyright and no portion may be reproduced without the permission of the ideArch designs.

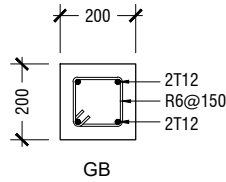

GB

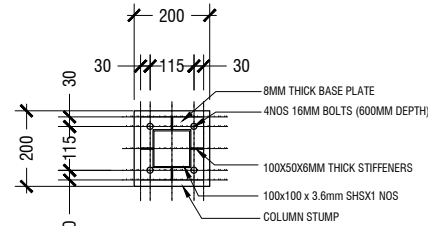

C1-PLATE VIEW

SCALE = 1:20

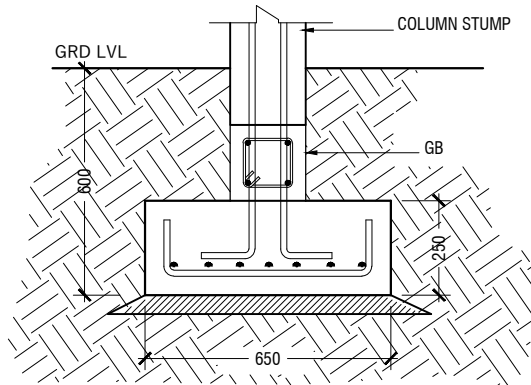

NOTE:

F1 = 650X650X250 (T10@70 BOT. B/W)  
FOUNDATION DEPTH = 600MM

TYPICAL FOOTING DETAIL

SCALE = 1:20

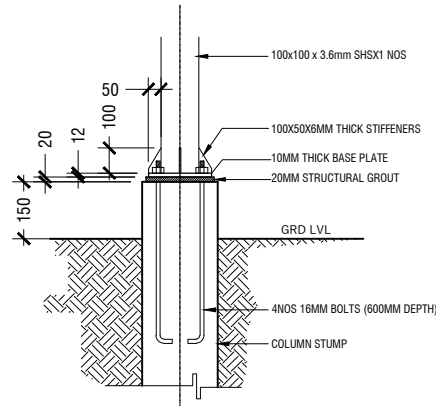

COLUMN C1 CONNECTION DETAIL

SCALE = 1:20

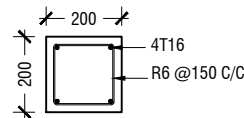

C1-STUMP DETAIL

SCALE = 1:20

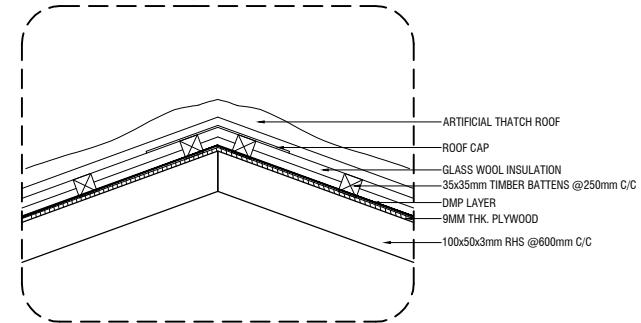

ROOFING DETAIL

SCALE = 1:20

NOTES:

- EXCEPT OTHERWISE NOTED:
- FOUNDATION PAD & BEAM COVER = 50 mm
  - COLUMN COVER = 40 mm
  - BEAM COVER = 35 mm
  - FLOOR SLAB COVER = 30 mm
  - MINIMUM CONCRETE GRADE = C25

CLIENT:  
G.A. KONDEY COUNCIL

PROJECT:  
**BEACH HUT 1**  
G.A. KONDEY

ARCHITECT:  
AHUSAN ABDUL MUHUSIN

ENGINEER:  
MOHAMED AHMEEM

SCALE: AS GIVEN

DRWNG TITLE : AS GIVEN

DATE: D07M09Y23



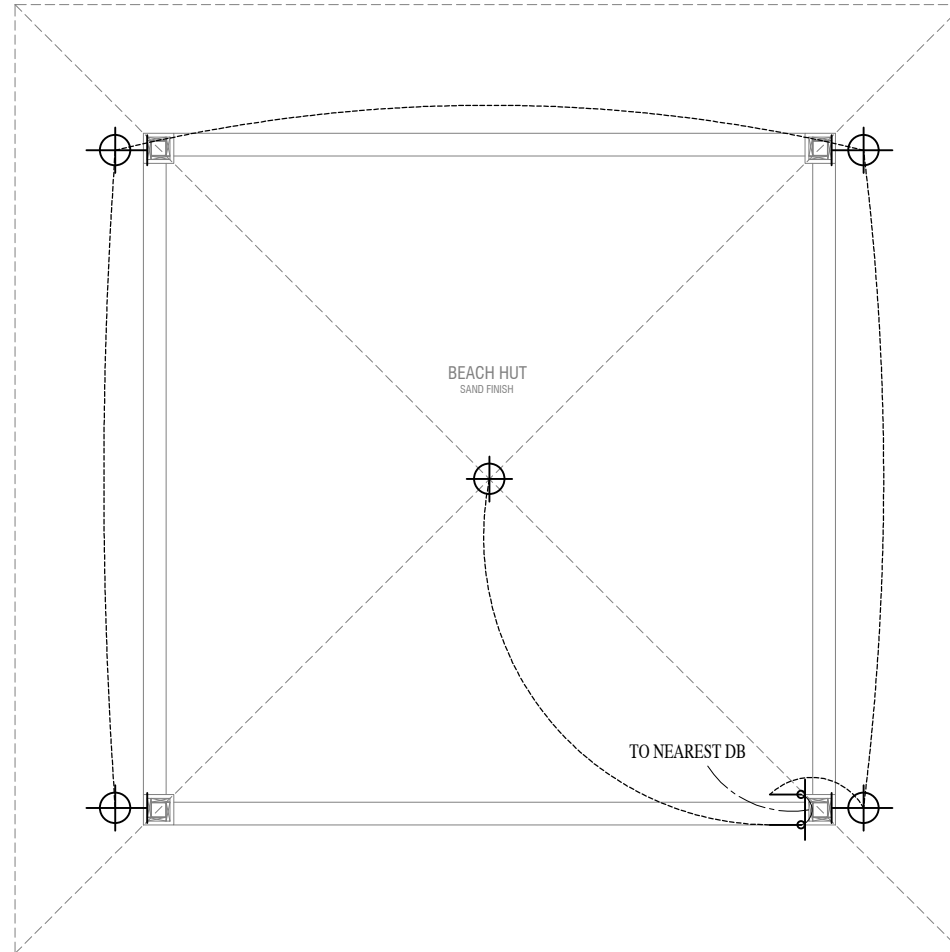

REVISION NO.: 00

FILE NAME:  
//IDEARCH/2023/PROJECTS/COMMERCIAL/  
BEACH HUT 1

**WARNING:**  
- This drawing shall not be used for construction unless certified.  
- Contractor to verify all dimensions of existing works on site before commencing any work or preparing shop drawings.  
- Do not scale drawings, use written dimensions only.  
- This drawing is to be read in conjunction with the specifications and conditions of contract.  
- This drawing and design is copyright and no portion may be reproduced without the permission of the ideArch designs.



**ELECTRICAL LEGEND**

-  CEILING LIGHT
-  WEATHER PROOF OUTDOOR LIGHT
-  ONE-WAY SWITCH
-  D-BOARD

**NOTE:**

THE DRAWINGS ARE SCHEMATIC. DETAILED SYSTEMS DESIGN AND CONDUITING SHALL BE DONE BY CONTRACTOR AND SUBMITTED FOR APPROVAL BEFORE INSTALLATION.

**BEACH HUT LIGHTING LAYOUT**

SCALE = 1:50

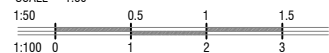

**EL01**