

بِسْمِ اللّٰهِ الرَّحْمٰنِ الرَّحِیْمِ



ދަޅުދަނޑިއި ޖަވާބު ދަލުދަނޑިއި ޖަވާބު
ދަލުދަނޑިއި ޖަވާބު

ދަލުދަނޑިއި ޖަވާބު

ޖަވާބު ދަލުދަނޑިއި ޖަވާބު ދަލުދަނޑިއި ޖަވާބު (ސަލާމަތް)
ދަލުދަނޑިއި ޖަވާބު ދަލުދަނޑިއި ޖަވާބު

ދަލުދަނޑިއި ޖަވާބު

400/PROJ/2023/05

ދަލުދަނޑިއި ޖަވާބު

(IUL)400/INDIV/2023/26

ދަލުދަނޑިއި ޖަވާބު

2023 19 ޖަވާބު

(1 ޖަވާބު)



ދަލުދަނޑިއި ޖަވާބު ދަލުދަނޑިއި ޖަވާބު
HADHDHUNMATHI
MAAVAH COUNCIL

2023 19 ޖަވާބު

+960 6800718
+960 7948480



info@maavahcouncil.gov.mv
www.maavahcouncil.gov.mv



ދަލުދަނޑިއި ޖަވާބު



(1) - 2018

<p>2.1.1 - 2018</p>	<p>2.1 - 2018</p>
<p>2.2.1 - 2018</p>	<p>2.2 - 2018</p>
<p>2.3.1 - 2018</p> <p>2.3.2 - 2018</p> <p>2.3.3 - 2018</p> <p>2.3.4 - 2018</p> <p>2.3.5 - 2018</p> <p>2.3.6 - 2018</p> <p>2.3.7 - 2018</p>	<p>2.3 - 2018</p>
<p>2.4.1 - 2018</p>	<p>2.4 - 2018</p>



2.5-1 - 2.5 - **2.5 - 2.5**
 2.5.1 - **2.5 - 2.5**
 2.5-1 - 2.5 - **2.5 - 2.5**
 2.5-1 - 2.5 - **2.5 - 2.5**

2.6 - 2.6
 2.6.1 - 2.6
 2.6.1 - 2.6
 2.6.1 - 2.6

2.6.1 - 2.6
 2.6.1 - 2.6
 2.6.1 - 2.6
 2.6.1 - 2.6
 2.6.1 - 2.6
 2.6.1 - 2.6
 2.6.1 - 2.6

(س) - 2.7

2.7-1 - 2.7
 2.7-1-1 - 2.7
 2.7-1-2 - 2.7
 2.7-1-3 - 2.7
 2.7-1-4 - 2.7
 2.7-1-5 - 2.7
 2.7-1-6 - 2.7

2.8-1 - 2.8
 2.8-2 - 2.8
 2.8-3 - 2.8

2.9-1 - 2.9
 2.9.1 - 2.9
 2.9.2 - 2.9



<p>2.21-1 - 2.21-1 - 2.21-1 - 2.21-1 - 2.21-1</p> <p>(A) ...</p> <p>(B) ...</p> <p>(C) ...</p>	<p>2-21 - 2-21 - 2-21 - 2-21 - 2-21</p> <p>... ..</p> <p>... ..</p> <p>... ..</p> <p>... ..</p>
<p>2.22-1 - 2.22-1 - 2.22-1 - 2.22-1 - 2.22-1</p>	<p>2-22 - 2-22 - 2-22 - 2-22 - 2-22</p> <p>... ..</p> <p>... ..</p>
<p>2.23-1 - 2.23-1 - 2.23-1 - 2.23-1 - 2.23-1</p>	<p>2-23 - 2-23 - 2-23 - 2-23 - 2-23</p> <p>... ..</p> <p>... ..</p>
<p>2.24-1 - 2.24-1 - 2.24-1 - 2.24-1 - 2.24-1</p> <p>... ..</p> <p>... ..</p> <p>... ..</p> <p>... ..</p>	<p>2-24 - 2-24 - 2-24 - 2-24 - 2-24</p> <p>... ..</p> <p>... ..</p> <p>... ..</p> <p>... ..</p>
<p>2.25-1 - 2.25-1 - 2.25-1 - 2.25-1 - 2.25-1</p>	<p>2-25 - 2-25 - 2-25 - 2-25 - 2-25</p> <p>... ..</p> <p>... ..</p>
<p>2.26-1 - 2.26-1 - 2.26-1 - 2.26-1 - 2.26-1</p> <p>2.26-2 - 2.26-2 - 2.26-2 - 2.26-2 - 2.26-2</p> <p>2.26-3 - 2.26-3 - 2.26-3 - 2.26-3 - 2.26-3</p> <p>17-19 - 17-19 - 17-19 - 17-19 - 17-19</p>	<p>2-26 - 2-26 - 2-26 - 2-26 - 2-26</p> <p>2-26 - 2-26 - 2-26 - 2-26 - 2-26</p> <p>2-26 - 2-26 - 2-26 - 2-26 - 2-26</p> <p>17-19 - 17-19 - 17-19 - 17-19 - 17-19</p>



17:20 17:20 17:20 17:20 17:20 17:20 17:20 17:20 17:20 17:20
 10 (10) 10 10 10 10 10 10 10 10 10 10
 10 10 10 10 10 10 10 10 10 10

(ع) - دہشت گردی کے واقعات

2.27-1 - 2.27-1 - 2.27-1 - 2.27-1 - 2.27-1 - 2.27-1 - 2.27-1 - 2.27-1 - 2.27-1 - 2.27-1
 17-09 17-09 17-09 17-09 17-09 17-09 17-09 17-09 17-09 17-09
 13-K/CIR/2018/01 13-K/CIR/2018/01 13-K/CIR/2018/01 13-K/CIR/2018/01 13-K/CIR/2018/01 13-K/CIR/2018/01 13-K/CIR/2018/01 13-K/CIR/2018/01 13-K/CIR/2018/01 13-K/CIR/2018/01
 PR-14 PR-14 PR-14 PR-14 PR-14 PR-14 PR-14 PR-14 PR-14 PR-14

2.27 - دہشت گردی
 دہشت گردی

2.28-1 - 2.28-1 - 2.28-1 - 2.28-1 - 2.28-1 - 2.28-1 - 2.28-1 - 2.28-1 - 2.28-1 - 2.28-1
 17-11 17-11 17-11 17-11 17-11 17-11 17-11 17-11 17-11 17-11
 13-K/CIR/2018/01 13-K/CIR/2018/01 13-K/CIR/2018/01 13-K/CIR/2018/01 13-K/CIR/2018/01 13-K/CIR/2018/01 13-K/CIR/2018/01 13-K/CIR/2018/01 13-K/CIR/2018/01 13-K/CIR/2018/01
 PR-16 PR-16 PR-16 PR-16 PR-16 PR-16 PR-16 PR-16 PR-16 PR-16

2.28 - دہشت گردی
 دہشت گردی
 دہشت گردی

3 - 3

<p>3-1-1 - 3-1-1 - 3-1-1 - 3-1-1 - 3-1-1 - 3-1-1 - 3-1-1 - 3-1-1 - 3-1-1 - 3-1-1 3-1-2 - 3-1-2 - 3-1-2 - 3-1-2 - 3-1-2 - 3-1-2 - 3-1-2 - 3-1-2 - 3-1-2 - 3-1-2 3-1-3 - 3-1-3 - 3-1-3 - 3-1-3 - 3-1-3 - 3-1-3 - 3-1-3 - 3-1-3 - 3-1-3 - 3-1-3</p>	<p>3.1 - دہشت گردی</p>
--	------------------------

<p>3-6 - 3.6 3.6-1 3.6-2</p>	<p>3.6-1 - 3.6-1 - 3.6-2</p> <p>3.6-1 - 3.6-1 - 3.6-2</p> <p>3.6-2 - 3.6-2</p>
<p>3-7 - 3.7 3.7-1</p>	<p>3-7-1 - 3.7-1</p> <p>3.7-1 - 3.7-1</p>
<p>3-8 - 3.8 3.8-1</p>	<p>3-8-1 - 3.8-1</p> <p>3.8-1 - 3.8-1</p>
<p>3-9 - 3.9 3.9-1</p>	<p>3-9-1 - 3.9-1</p> <p>3.9-1 - 3.9-1</p>
<p>3-10 - 3.10 3.10-1</p>	<p>3-10-1 - 3.10-1</p> <p>3.10-1 - 3.10-1</p>
<p>3-11 - 3.11 3.11-1 3.11-2</p>	<p>3-11-1 - 3.11-1</p> <p>3-11-2 - 3.11-2</p> <p>3.11-1 - 3.11-1</p> <p>3.11-2 - 3.11-2</p>
<p>3-12 - 3.12 3.12-1 3.12-2</p>	<p>3-12-1 - 3.12-1</p> <p>3-12-2 - 3.12-2</p> <p>3.12-1 - 3.12-1</p> <p>3.12-2 - 3.12-2</p>



1 - ބަދަލު

ބަދަލުގެ ވަގުތު ބަދަލުގެ ވަގުތު ބަދަލުގެ ވަގުތު

<p>މަދަރުފާނުގެ ނަންމެންނަން</p>	<p>މަދަރުފާނުގެ ބަދަލުގެ ވަގުތު</p>	<p>މަދަރުފާނުގެ ބަދަލުގެ ވަގުތު</p>	<p>#</p>
		ބަދަލުގެ ވަގުތު (2 ބަދަލު)	1
		މަދަރުފާނުގެ ބަދަލު (3 ބަދަލު)	2
		މަދަރުފާނުގެ ބަދަލު ބަދަލުގެ ވަގުތު ބަދަލުގެ ވަގުތު ބަދަލުގެ ވަގުތު ބަދަލުގެ ވަގުތު	3
		މަދަރުފާނުގެ ބަދަލު (6 ބަދަލު ، ބަދަލުގެ ވަގުތު ، ބަދަލުގެ ވަގުތު) (ބަދަލު)	4
		ބަދަލުގެ ވަގުތު ބަދަލުގެ ވަގުތު (ބަދަލުގެ ވަގުތު ބަދަލުގެ ވަގުތު)	5
		ބަދަލުގެ ވަގުތު ބަދަލުގެ ވަގުތު (ބަދަލުގެ ވަގުތު ބަދަލުގެ ވަގުތު)	6
		ބަދަލުގެ ވަގުތު 2-6.1 ބަދަލުގެ ވަގުތު ބަދަލުގެ ވަގުތު	7
<p>ބަދަލުގެ ވަގުތު ބަދަލުގެ ވަގުތު ބަދަލުގެ ވަގުތު ބަދަލުގެ ވަގުތު ބަދަލުގެ ވަގުތު</p>			
		ބަދަލުގެ ވަގުތު ބަދަލުގެ ވަގުތު ބަދަލުގެ ވަގުތު ބަދަލުގެ ވަގުތު (4 ބަދަލު 10 ބަދަލު ބަދަލުގެ ވަގުތު ބަދަލުގެ ވަގުތު)	8
<p>ބަދަލުގެ ވަގުތު ބަދަލުގެ ވަގުތު ބަދަލުގެ ވަގުތު ބަދަލުގެ ވަގުތު ބަދަލުގެ ވަގުތު</p>			
		މަދަރުފާނުގެ ބަދަލުގެ ވަގުތު ބަދަލުގެ ވަގުތު ބަދަލުގެ ވަގުތު	9
		ބަދަލުގެ ވަގުތު ބަދަލުގެ ވަގުތު (ބަދަލުގެ ވަގުތު ބަދަލުގެ ވަގުތު) (ބަދަލުގެ ވަގުތު)	10
		ބަދަލުގެ ވަގުތު ބަދަލުގެ ވަގުތު ބަދަލުގެ ވަގުތު ބަދަލުގެ ވަގުތު	11
		ބަދަލުގެ ވަގުތު ބަދަލުގެ ވަގުތު ބަދަލުގެ ވަގުތު ބަދަލުގެ ވަގުތު	12

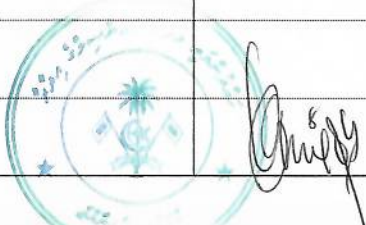

2 - 2023 2024 2025

1- 2023 2024 2025	
1-1	2023 2024 2025
1-2	2023 2024 2025
1-3	2023 2024 2025
2- 2023 2024 2025	
2-1	2023 2024 2025
2-2	400/PROJ/2023/5
2-3	(IUL)400/INDIV/2023/26
3- 2023 2024 2025	
3-1	2023 2024 2025
	2023 2024 2025
	2023 2024 2025
3-2	2023 2024 2025
3-3	2023 2024 2025
4- 2023 2024 2025	
4-1	2023 2024 2025
4-2	2023 2024 2025
4-3	2023 2024 2025
2023 2024 2025	
2023 2024 2025	
2023 2024 2025	
2023 2024 2025	

2023 2024 2025

උදාහරණ - 5, පවුලක සාමාජිකයන්ගේ සංඛ්‍යාව සඳහා වන පවුලක සාමාජිකයන්ගේ සංඛ්‍යාව

පවුලක සාමාජිකයන්ගේ සංඛ්‍යාව	පවුලක සාමාජිකයන්ගේ සංඛ්‍යාව	පවුලක සාමාජිකයන්ගේ සංඛ්‍යාව
80	<p>පවුලක සාමාජිකයන්ගේ සංඛ්‍යාව 80 වන විට, පවුලක සාමාජිකයන්ගේ සංඛ්‍යාව 80 වන විට, පවුලක සාමාජිකයන්ගේ සංඛ්‍යාව 80 වන විට.</p> $80 \times \frac{\text{පවුලක සාමාජිකයන්ගේ සංඛ්‍යාව}}{\text{පවුලක සාමාජිකයන්ගේ සංඛ්‍යාව}} = \text{පවුලක සාමාජිකයන්ගේ සංඛ්‍යාව}$	80
10	<p>පවුලක සාමාජිකයන්ගේ සංඛ්‍යාව 10 වන විට, පවුලක සාමාජිකයන්ගේ සංඛ්‍යාව 10 වන විට, පවුලක සාමාජිකයන්ගේ සංඛ්‍යාව 10 වන විට.</p> $10 \times \frac{\text{පවුලක සාමාජිකයන්ගේ සංඛ්‍යාව}}{\text{පවුලක සාමාජිකයන්ගේ සංඛ්‍යාව}} = \text{පවුලක සාමාජිකයන්ගේ සංඛ්‍යාව}$	10
10	<p>පවුලක සාමාජිකයන්ගේ සංඛ්‍යාව 10 වන විට, පවුලක සාමාජිකයන්ගේ සංඛ්‍යාව 10 වන විට, පවුලක සාමාජිකයන්ගේ සංඛ්‍යාව 10 වන විට.</p> <p>(පවුලක සාමාජිකයන්ගේ සංඛ්‍යාව 10 වන විට, පවුලක සාමාජිකයන්ගේ සංඛ්‍යාව 10 වන විට, පවුලක සාමාජිකයන්ගේ සංඛ්‍යාව 10 වන විට.)</p> <p>පවුලක සාමාජිකයන්ගේ සංඛ්‍යාව 10 වන විට, පවුලක සාමාජිකයන්ගේ සංඛ්‍යාව 10 වන විට, පවුලක සාමාජිකයන්ගේ සංඛ්‍යාව 10 වන විට.</p> $10 \times \frac{\text{පවුලක සාමාජිකයන්ගේ සංඛ්‍යාව}}{\text{පවුලක සාමාජිකයන්ගේ සංඛ්‍යාව}} = \text{පවුලක සාමාජිකයන්ගේ සංඛ්‍යාව}$	10
100		100

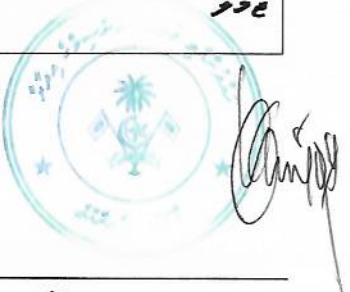

Form of Bid Security (Bank Guarantee)

WHEREAS,[name of Bidder] (hereinafter called "the Bidder") has submitted his Bid for the Project no.....issued by the Ministry of Finance and Treasury onfor construction of[name of Contract] (hereinafter called "the Bid").

KNOW ALL PEOPLE by these presents that We [name of Bank] of [name of country] having our registered office at (hereinafter called "the Bank") are bound unto [name of Purchaser] (hereinafter called "the Purchaser") in the sum of *..... for which payment well and truly to be made to the said Purchaser, the Bank binds itself, its successors, and assigns by these presents.

SEALED with the Common Seal of the said Bank thisday of20.....

THE CONDITIONS of this obligation are:

- (1) If, after Bid opening, the Bidder withdraws his Bid during the period of Bid validity specified in the Form of Bid;
- or
- (2) If the Bidder having been notified of the acceptance of his Bid by the Purchaser during the period of Bid validity:
 - (a) fails or refuses to execute the Form of Agreement in accordance with the Instructions to Bidders, if required; or
 - (b) fails or refuses to furnish the Performance Security, in accordance with the Instruction to Bidders; or
 - (c) does not accept the correction of the Bid Price pursuant to Clause 27,

* The Bidder should insert the amount of the Guarantee in words and figures denominated in Maldivian Rufiyaa. This figure should be the same as shown in Clause 16.1.7 of the Instructions to Bidders.

we undertake to pay to the Purchaser up to the above amount upon receipt of his first written demand, without the Purchaser's having to substantiate his demand, provided that in his demand the Purchaser will note that the amount claimed by him is due to him owing to the occurrence of one or any of the three conditions, specifying the occurred condition or conditions.

This Guarantee will remain in force up to and including the date days after the deadline for submission of bids as such deadline is stated in the Instructions to Bidders or as it may be extended by the Purchaser, notice of which extension(s) to the Bank is hereby waived. Any demand in respect of this Guarantee should reach the Bank not later than the above date.

DATE..... SIGNATURE OF THE BANK

WITNESS SEAL

[signature, name, and address]



Form of Performance Bank Guarantee (Unconditional)

To:
[name & address of Purchaser]
.....
.....

WHEREAS [name and address of Supplier] (hereinafter called "the Supplier") has undertaken, in pursuance of Contract No. dated to execute [name of Contract and brief description of Works] (hereinafter called "the Contract");

AND WHEREAS it has been stipulated by you in the said Contract that the Supplier shall furnish you with a Bank Guarantee by a recognized bank for the sum specified therein as security for compliance with his obligations in accordance with the Contract;

AND WHEREAS we have agreed to give the Supplier such a Bank Guarantee;

NOW THEREFORE we hereby affirm that we are the Guarantor and responsible to you, on behalf of the Supplier, up to a total of *..... [amount of Guarantee] [amount in words], such sum being payable in the types and proportions of currencies in which the Contract Price is payable, and we undertake to pay you, upon your first written demand and without cavil or argument, any sum or sums within the limits of [amount of Guarantee] as aforesaid without your needing to prove or to show grounds or reasons for your demand for the sum specified therein.

*An amount is to be inserted by the Guarantor, representing the percentage of the Contract Price specified in the Contract, in Maldivian Rufiyaa.

We hereby waive the necessity of your demanding the said debt from the Supplier before presenting us with the demand.

We further agree that no change or addition to or other modification of the terms of the Contract or of the Works to be performed there under or of any of the Contract documents which may be made between you and the Supplier shall in any way release us from any liability under this Guarantee, and we hereby waive notice of any such change, addition, or modification.

This Guarantee shall be valid until the date of issue of the Defects Correction Certificate.

SIGNATURE AND SEAL OF THE GUARANTOR

Name of Bank

Address

Date



ලැබේ. ජනප්‍රියතාවය පරිදි සැලකිලිමත් කරනු ලබන සේ මුදල් හුවමාරු කිරීමේදී සේවාවලට දායකත්වයක් ලබාදීමට හැකි වන පරිදි පවත්වා ගැනීමට කටයුතු කළ යුතුය.

11.2 ක් අධිකාරියේ 9 වන කොටසේ සඳහන් කර ඇති පරිදි කටයුතු සම්බන්ධයෙන් පවත්වා ගැනීමේදී නීතිමය සේවාවලට දායකත්වයක් ලබාදීමට හැකි වන පරිදි පවත්වා ගැනීමට කටයුතු කළ යුතුය. ජනප්‍රියතාවය පරිදි සැලකිලිමත් කරනු ලබන සේ මුදල් හුවමාරු කිරීමේදී සේවාවලට දායකත්වයක් ලබාදීමට හැකි වන පරිදි පවත්වා ගැනීමට කටයුතු කළ යුතුය.

12. අධිකාරියේ සේවාවලට දායකත්වය ලබාදීම

12.1 ක් අධිකාරියේ 3 වන කොටසේ 3.1 ක් සඳහන් කර ඇති පරිදි, සේවාවලට දායකත්වයක් ලබාදීමේදී සේවාවලට දායකත්වයක් ලබාදීමට හැකි වන පරිදි පවත්වා ගැනීමට කටයුතු කළ යුතුය. අධිකාරියේ සේවාවලට දායකත්වයක් ලබාදීමේදී සේවාවලට දායකත්වයක් ලබාදීමට හැකි වන පරිදි පවත්වා ගැනීමට කටයුතු කළ යුතුය.

12.2 ක් අධිකාරියේ 10 වන කොටසේ සඳහන් කර ඇති පරිදි සේවාවලට දායකත්වයක් ලබාදීමේදී සේවාවලට දායකත්වයක් ලබාදීමට හැකි වන පරිදි පවත්වා ගැනීමට කටයුතු කළ යුතුය. 15% (පහත) පමණක් සේවාවලට දායකත්වයක් ලබාදීමට හැකි වන පරිදි පවත්වා ගැනීමට කටයුතු කළ යුතුය.

12.3 ක් අධිකාරියේ 11 වන කොටසේ 11.2 ක් සඳහන් කර ඇති පරිදි සේවාවලට දායකත්වයක් ලබාදීමේදී සේවාවලට දායකත්වයක් ලබාදීමට හැකි වන පරිදි පවත්වා ගැනීමට කටයුතු කළ යුතුය. 14 (පහත) කොටසේ සඳහන් කර ඇති පරිදි සේවාවලට දායකත්වයක් ලබාදීමට හැකි වන පරිදි පවත්වා ගැනීමට කටයුතු කළ යුතුය.

12.4 ක් අධිකාරියේ සේවාවලට දායකත්වයක් ලබාදීමේදී සේවාවලට දායකත්වයක් ලබාදීමට හැකි වන පරිදි පවත්වා ගැනීමට කටයුතු කළ යුතුය. 14 (පහත) කොටසේ සඳහන් කර ඇති පරිදි සේවාවලට දායකත්වයක් ලබාදීමට හැකි වන පරිදි පවත්වා ගැනීමට කටයුතු කළ යුතුය.

13. සේවාවලට දායකත්වය ලබාදීම

13.1 ක් අධිකාරියේ සේවාවලට දායකත්වයක් ලබාදීමේදී සේවාවලට දායකත්වයක් ලබාදීමට හැකි වන පරිදි පවත්වා ගැනීමට කටයුතු කළ යුතුය.

13.2 ක් අධිකාරියේ සේවාවලට දායකත්වයක් ලබාදීමේදී සේවාවලට දායකත්වයක් ලබාදීමට හැකි වන පරිදි පවත්වා ගැනීමට කටයුතු කළ යුතුය.

13.3 ක් අධිකාරියේ 13.2 ක් සඳහන් කර ඇති පරිදි සේවාවලට දායකත්වයක් ලබාදීමේදී සේවාවලට දායකත්වයක් ලබාදීමට හැකි වන පරිදි පවත්වා ගැනීමට කටයුතු කළ යුතුය.



މަޢުލޫމާތު ބޯޅަވާ ނިންމާލުމުގެ ނިންމާލުމުގެ ބަޔާން (ދިވެހިރާއްޖޭގެ ޖުމްހޫރިއްޔާ ގުޅިގެން) ވަނަ ފަހަރުގެ ބަޔާން 2 ވަނަ ބައި ސަބަބުތަކާ ގުޅިގެން
 ފަހަރުގެ ބަޔާން ފަހަރުގެ ބަޔާން

މަޢުލޫމާތު ބޯޅަވާ ނިންމާލުމުގެ ބަޔާން

މަޢުލޫމާތު ބޯޅަވާ ނިންމާލުމުގެ ބަޔާން

ނަންމު: _____
 ސަރުކާރު: _____
 ފަންޓްޕް: _____
 ދިވެހިރާއްޖެ: _____

ނަންމު: _____
 ސަރުކާރު: _____
 ފަންޓްޕް: _____
 ދިވެހިރާއްޖެ: _____

ނަންމު

ނަންމު

ނަންމު

ނަންމު

ސަރުކާރު

ސަރުކާރު

ފަންޓްޕް: -

ފަންޓްޕް: -

ދިވެހިރާއްޖެ ސަރުކާރު

ދިވެހިރާއްޖެ ސަރުކާރު

މަޢުލޫމާތު ބޯޅަވާ ނިންމާލުމުގެ ބަޔާން

މަޢުލޫމާތު ބޯޅަވާ ނިންމާލުމުގެ ބަޔާން

ނަންމު: _____

ނަންމު: _____

ސަރުކާރު: _____

ސަރުކާރު: _____

ފަންޓްޕް: _____

ފަންޓްޕް: _____

ދިވެހިރާއްޖެ ސަރުކާރު

ދިވެހިރާއްޖެ ސަރުކާރު

ފަންޓްޕް: _____

ފަންޓްޕް: _____ info@maavahcouncil.gov.mv



ބަނޑުގެ ނަންބަރު، ފަންޓު، ފަންޓުގެ ނަންބަރު (ވިޔަފުހާ)

ވަނަ ބައި 1: ބަނޑުގެ ފަންޓު

ބަނޑުގެ ނަންބަރު (ވިޔަފުހާ)	ފަންޓުގެ ނަންބަރު		ބަނޑުގެ ނަންބަރު			#
	ފަންޓުގެ ނަންބަރު (ވިޔަފުހާ)	ފަންޓުގެ ނަންބަރު (ވިޔަފުހާ)	ފަންޓު	ފަންޓު	ބަނޑުގެ ނަންބަރު	
			1	LOT SET	Supply of 10kW Three Phase Grid-Tied Rooftop Solar PV System: Photovoltaic Modules, Inverter Mounting Structure Cables MC4 Connectors, AC Isolation Box Net Meter Earthing Materials Other Consumables	1

ވަނަ ބައި 2: ބަނޑުގެ ފަންޓު

ބަނޑުގެ ނަންބަރު (ވިޔަފުހާ)	ފަންޓުގެ ނަންބަރު		ބަނޑުގެ ނަންބަރު			#
	ފަންޓުގެ ނަންބަރު (ވިޔަފުހާ)	ފަންޓުގެ ނަންބަރު (ވިޔަފުހާ)	ފަންޓު	ފަންޓު	ބަނޑުގެ ނަންބަރު	
			1	-	ބަނޑުގެ ފަންޓުގެ ނަންބަރު (ވިޔަފުހާ) ބަނޑުގެ ފަންޓުގެ ނަންބަރު (ވިޔަފުހާ) ބަނޑުގެ ފަންޓުގެ ނަންބަރު (ވިޔަފުހާ) ބަނޑުގެ ފަންޓުގެ ނަންބަރު (ވިޔަފުހާ) ބަނޑުގެ ފަންޓުގެ ނަންބަރު (ވިޔަފުހާ) ބަނޑުގެ ފަންޓުގެ ނަންބަރު (ވިޔަފުހާ) ބަނޑުގެ ފަންޓުގެ ނަންބަރު (ވިޔަފުހާ)	1



1. 2020 / 2020 / 2020

1. 2020 / 2020 / 2020

- I. 2020 / 2020 / 2020 (2020 / 2020 / 2020)
- II. 2020 / 2020 / 2020 (3 / 2020 / 2020 / 2020)
- III. 2020 / 2020 / 2020 (3 / 2020 / 2020 / 2020)
- IV. 2020 / 2020 / 2020 (2020 / 2020 / 2020 / 2020)
- V. 2020 / 2020 / 2020 (2020 / 2020 / 2020 / 2020)
- VI. 2020 / 2020 / 2020 (2020 / 2020 / 2020 / 2020)
- VII. 2020 / 2020 / 2020 (2020 / 2020 / 2020 / 2020)
- VIII. 2020 / 2020 / 2020 (3 / 2020 / 2020 / 2020)
- IX. 2020 / 2020 / 2020 (2020 / 2020 / 2020 / 2020)
- X. 2020 / 2020 / 2020 (2020 / 2020 / 2020 / 2020)



XI. ޖަނަވަރުގެ ރަޖިސްޓްރޭޝަން ފޯމުގެ ދަށުން ޖަނަވަރު ރަޖިސްޓްރޭޝަން ސެކްޝަނުން ރަޖިސްޓްރޭޝަން ފޯމު ފުރިހަމަކުރުމަށް ފޮނުވާ ފޯމު.

ދަނީ ފުރިހަމަކުރުމަށް ފޮނުވާ ފޯމު.

XII. ސަލާމަތް ޖަނަވަރުގެ ރަޖިސްޓްރޭޝަން ފޯމުގެ ދަށުން ޖަނަވަރު ރަޖިސްޓްރޭޝަން ސެކްޝަނުން ރަޖިސްޓްރޭޝަން ފޯމު ފުރިހަމަކުރުމަށް ފޮނުވާ ފޯމު.

ދަނީ ފުރިހަމަކުރުމަށް ފޮނުވާ ފޯމު.

XIII. ރަޖިސްޓްރޭޝަން ފޯމުގެ ދަށުން ޖަނަވަރު ރަޖިސްޓްރޭޝަން ސެކްޝަނުން ރަޖިސްޓްރޭޝަން ފޯމު ފުރިހަމަކުރުމަށް ފޮނުވާ ފޯމު (4 ވަނަ ބައި).

XIV. ފަންނީ ޖަނަވަރުގެ ރަޖިސްޓްރޭޝަން ފޯމުގެ ދަށުން ޖަނަވަރު ރަޖިސްޓްރޭޝަން ސެކްޝަނުން ރަޖިސްޓްރޭޝަން ފޯމު ފުރިހަމަކުރުމަށް ފޮނުވާ ފޯމު (2 ވަނަ ބައި).

XV. ރަޖިސްޓްރޭޝަން ފޯމުގެ ދަށުން ޖަނަވަރު ރަޖިސްޓްރޭޝަން ސެކްޝަނުން ރަޖިސްޓްރޭޝަން ފޯމު ފުރިހަމަކުރުމަށް ފޮނުވާ ފޯމު (3 ވަނަ ބައި).

ދަނީ ފުރިހަމަކުރުމަށް ފޮނުވާ ފޯމު.



Requirements for major equipment:

1. Photovoltaic (PV) module

- 1.1. The PV module must qualify the latest edition of any of the following IEC PV module qualification OR equivalent to BS standards.
- 1.2. The PV modules must qualify to IEC 61730-1 (photovoltaic (PV) module safety qualification – Part 1: Requirements for construction) and IEC 61730-2 (photovoltaic (PV) module safety qualification – Part 2: Requirements for testing).
- 1.3. PV modules to be used in highly corrosive atmosphere throughout their lifetime and must qualify to IEC 61701 (Photovoltaic (PV) modules – Salt mist corrosion testing).
- 1.4. The total power shall be obtained by streams of PV modules.
- 1.5. PV modules shall be either monocrystalline OR polycrystalline.
- 1.6. PV modules shall be in 1/3-cut cell layout Mono PERC technology.
- 1.7. PV modules shall be PID resistant.
- 1.8. PV modules shall be aluminum framed with hard face covers.
- 1.9. PV module selection shall be made from state of the art of the PV technology with the best relation.
- 1.10. space/production as possible.
- 1.11. PV module brand/s should be declared with datasheet and justified.
- 1.12. Stream voltages should be average voltage to avoid losses on low voltage transfer which increases the length of wiring and not too high to avoid magnetic field production with relevant thunder shot possibility.
- 1.13. PV modules shall come to site properly tested and in good packaged to avoid any damage.
- 1.14. PV modules shall be guaranteeing 20 years power performance with not more than 2% power degradation in first year and 0.55% annual power attenuation.
- 1.15. PV modules shall be guaranteed for 10 years against any kind of production defect.

2. On -Grid Inverter

- 2.1. The contractor shall supply all necessary on-grid inverters for the correct operation of the system and which allow for future expansion of the PV power plant in phases.
- 2.2. The council expects the contractor to propose robust, reliable and low failure rate proven inverters which can work efficiently for more than 10 years without any major failure in hot and humid environments.

2.3. The contractor shall provide details of the following characteristics for each inverter

- 2.3.1. Max input power
 - 2.3.2. Max output power
 - 2.3.3. Efficiency rating
 - 2.3.4. Protection features
 - 2.3.5. Voltage and power ratings
 - 2.3.6. Communication capabilities
 - 2.3.7. Operating parameters
 - 2.3.8. Controls and displays.
 - 2.3.9. Standards and certifications
- 2.4. The inverters shall have an efficiency of 97% and above.
 - 2.5. The inverters shall have an inbuilt DC isolation switch.
 - 2.6. The inverters shall have surge protection.
 - 2.7. The inverter must have the capability to monitor.



2.8. The inverters brands must be from one of the brands.

- 2.8.1. ABB
- 2.8.2. Enphase Energy
- 2.8.3. Huawei
- 2.8.4. Fronius International GmbH
- 2.8.5. Ginlong Solis
- 2.8.6. SMA Solar Technology AG

2.9. Warranty

- 2.9.1. PV modules used must be warranted by the manufacturer for output wattage, which should not be less than 90% within the first 10 years and 80% at the end of 20 years.
- 2.9.2. The inverter must be 5 years manufacture backed warranty.
- 2.9.3. Contractor must be responsible for service warranty at least 2 years from the date of PV panel commissioning date.



Single Line Drawing

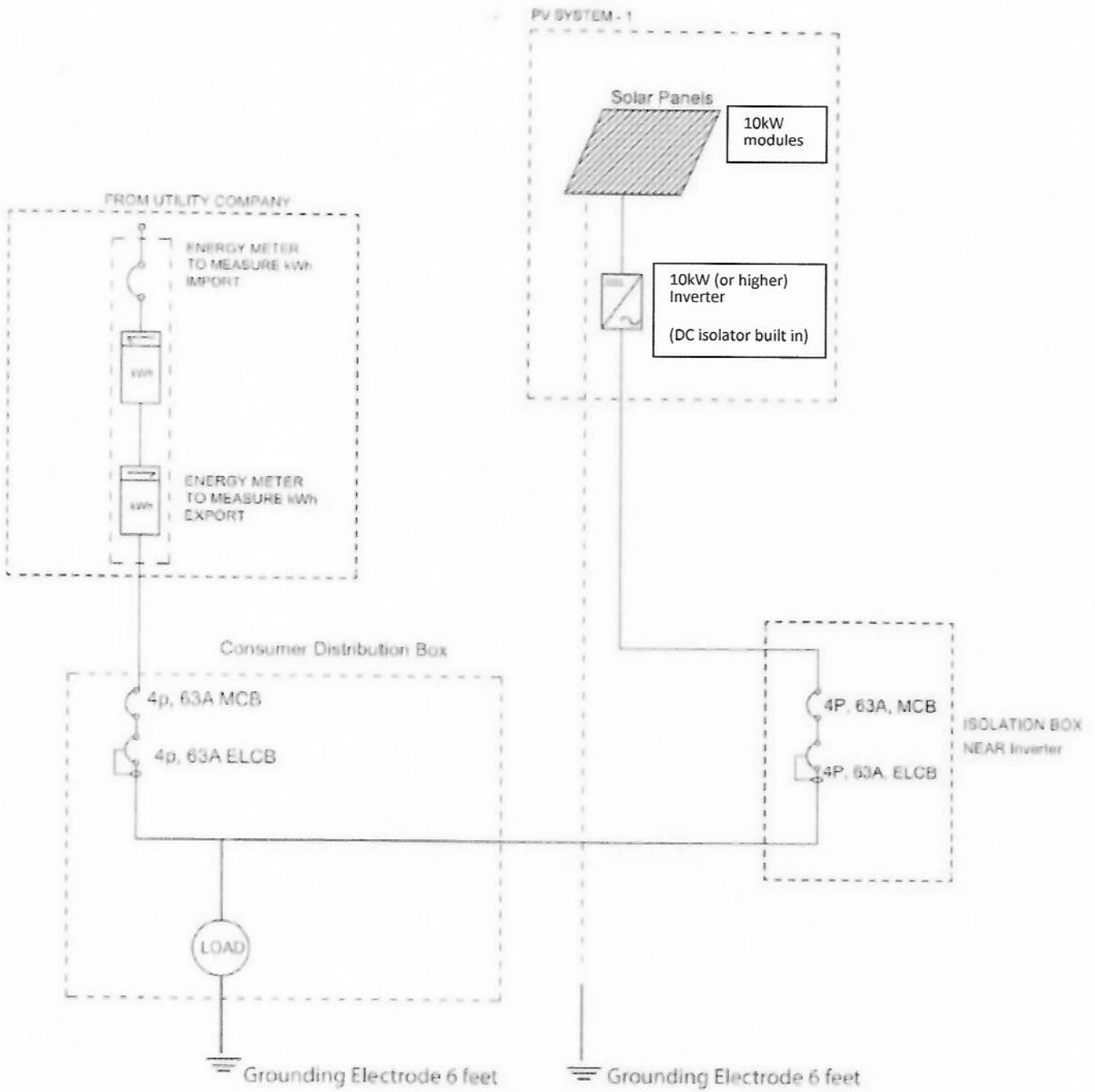



ڊيٽا
ڊسٽريبيوٽيڊ

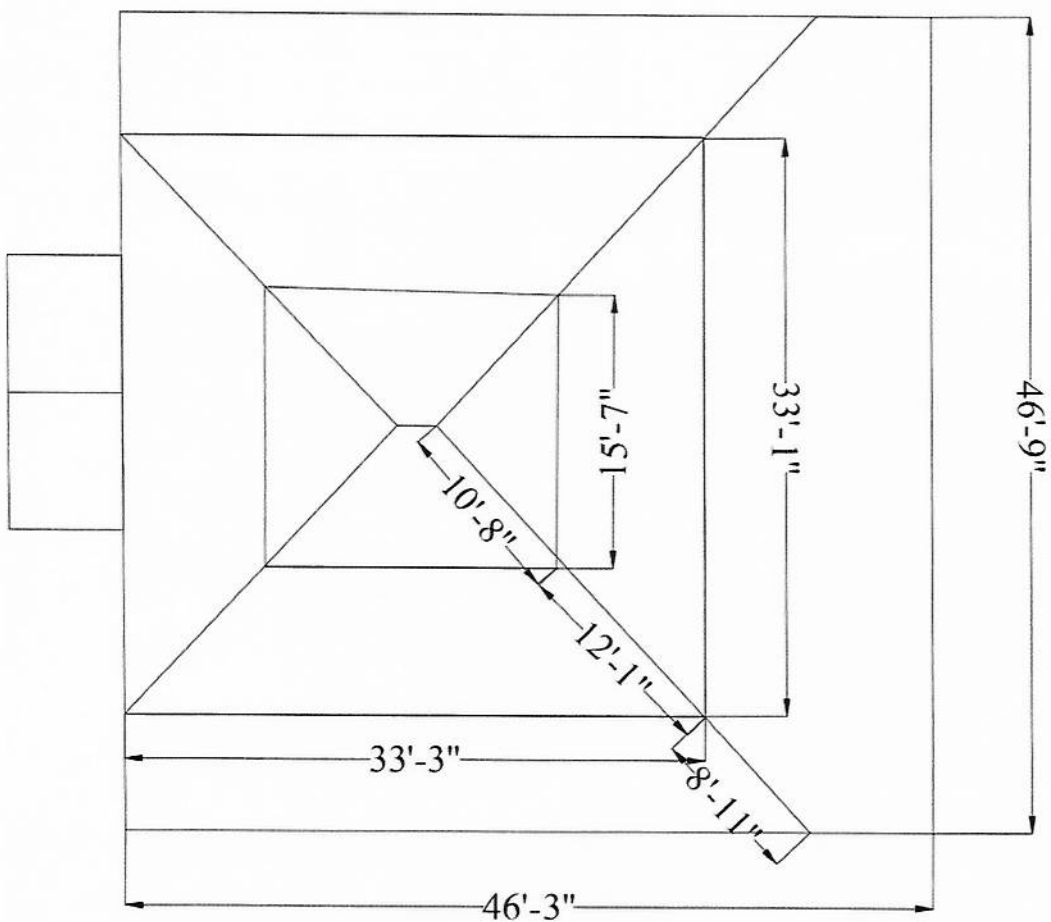

Handwritten signature

DB Box
Meter
Inverter

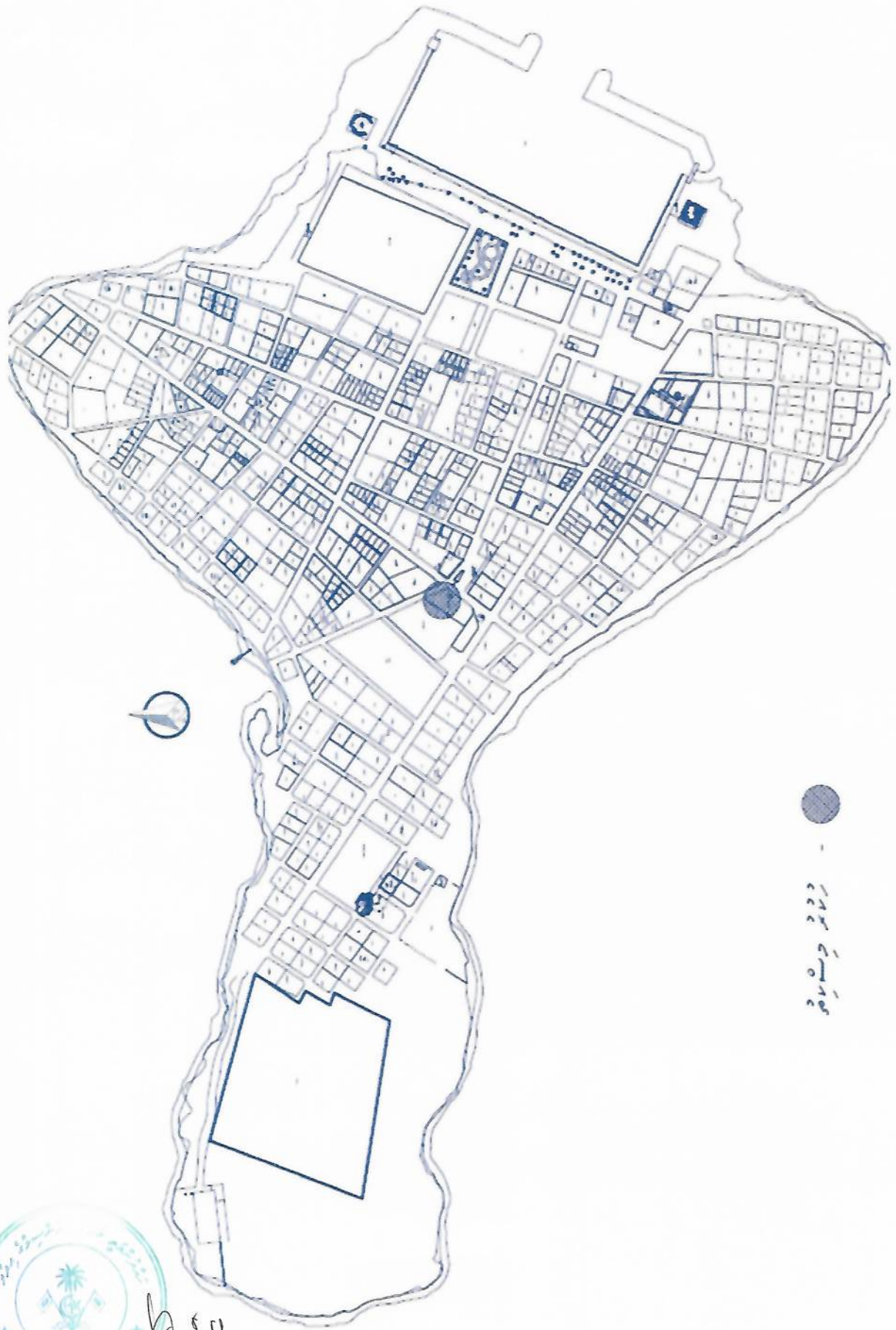

[Handwritten signature]