



ސަލާމަތުގެ ސަރުކާރުގެ ސެކްރެޓަރިޓް

ފާދިބު ނާއިފަރު ސަރުކާރުގެ ސެކްރެޓަރިޓް ގެ ސަރުކާރުގެ ސެކްރެޓަރިޓް ގެ ސަރުކާރުގެ ސެކްރެޓަރިޓް (2 ވަނަ ފަހަރު ނާއިފަރު ސަރުކާރުގެ ސެކްރެޓަރިޓް)

ފާދިބު ނާއިފަރު ސަރުކާރުގެ ސެކްރެޓަރިޓް: (IUL)327-A/327/2023/342

ފާދިބު ނާއިފަރު ސަރުކާރުގެ ސެކްރެޓަރިޓް:

ފާދިބު ނާއިފަރު ސަރުކާރުގެ ސެކްރެޓަރިޓް: 18 ޔުނިވަރްސަލް 2023

ފާދިބު ނާއިފަރު ސަރުކާރުގެ ސެކްރެޓަރިޓް: 26 ޔުނިވަރްސަލް 2023



අනුකූලව පරීක්ෂණය කිරීමට ඉඩ ඇත. **දැනුම් දීමට සූදානම්.** මුද්දරයට පත්වීමට ඉඩ ඇත.

එදිනෙදා 8 වැනි දිනට.

30.4 නිවැරදිව පවතින බවට තීරණය කිරීමට "සාමාන්‍ය" අයුරින් පවතින බවට තීරණය කිරීමට සූදානම්. අනුකූලව පවතින බවට තීරණය කිරීමට සූදානම්. අනුකූලව පවතින බවට තීරණය කිරීමට සූදානම්.

31.1 තීරණය කිරීමට සූදානම් 11:01 වැනි දිනට පවතින බවට තීරණය කිරීමට සූදානම්. අනුකූලව පවතින බවට තීරණය කිරීමට සූදානම්. අනුකූලව පවතින බවට තීරණය කිරීමට සූදානම්. අනුකූලව පවතින බවට තීරණය කිරීමට සූදානම්.

31. දැනුම් දීමට සූදානම්

31.2 තීරණය කිරීමට සූදානම් 11:02 වැනි දිනට පවතින බවට තීරණය කිරීමට සූදානම්. අනුකූලව පවතින බවට තීරණය කිරීමට සූදානම්. අනුකූලව පවතින බවට තීරණය කිරීමට සූදානම්. අනුකූලව පවතින බවට තීරණය කිරීමට සූදානම්.

31.3 තීරණය කිරීමට සූදානම් 11:02 වැනි දිනට පවතින බවට තීරණය කිරීමට සූදානම්. අනුකූලව පවතින බවට තීරණය කිරීමට සූදානම්. අනුකූලව පවතින බවට තීරණය කිරීමට සූදානම්. අනුකූලව පවතින බවට තීරණය කිරීමට සූදානම්.

31.4 තීරණය කිරීමට සූදානම් 11:03 වැනි දිනට පවතින බවට තීරණය කිරීමට සූදානම්. අනුකූලව පවතින බවට තීරණය කිරීමට සූදානම්. අනුකූලව පවතින බවට තීරණය කිරීමට සූදානම්. අනුකූලව පවතින බවට තීරණය කිරීමට සූදානම්.

32.1 තීරණය කිරීමට සූදානම් 11:03 වැනි දිනට පවතින බවට තීරණය කිරීමට සූදානම්. අනුකූලව පවතින බවට තීරණය කිරීමට සූදානම්. අනුකූලව පවතින බවට තීරණය කිරීමට සූදානම්. අනුකූලව පවතින බවට තීරණය කිරීමට සූදානම්.

32. දැනුම් දීමට සූදානම්



1 ފަންނު

ދިވެހިރާއްޖޭގެ ޖުމްހޫރީ ޖުމްހޫރީ ސަރުކާރުގެ (ދިވެހި) ޖުމްހޫރީ



lhnaifarucouncil



www.naifaru.gov.mv







info@naifaru.gov.mv



6620068



FOR INSTALLATION DETAILS OF PARK EQUIPMENTS
PLEASE REFER TO STRUCTURAL INSTALLATION OF PARK EQUIPMENTS

-  ARTIFICIAL GRASS CARPET
-  100 MM THICK REINFORCED CONCRETE SLAB
-  WALL MOUNT OUTDOOR, WATERPROOF LIGHTS
-  OUTDOOR, WATERPROOF GARDEN LIGHTS
-  ELECTRICAL DISTRIBUTION BOX

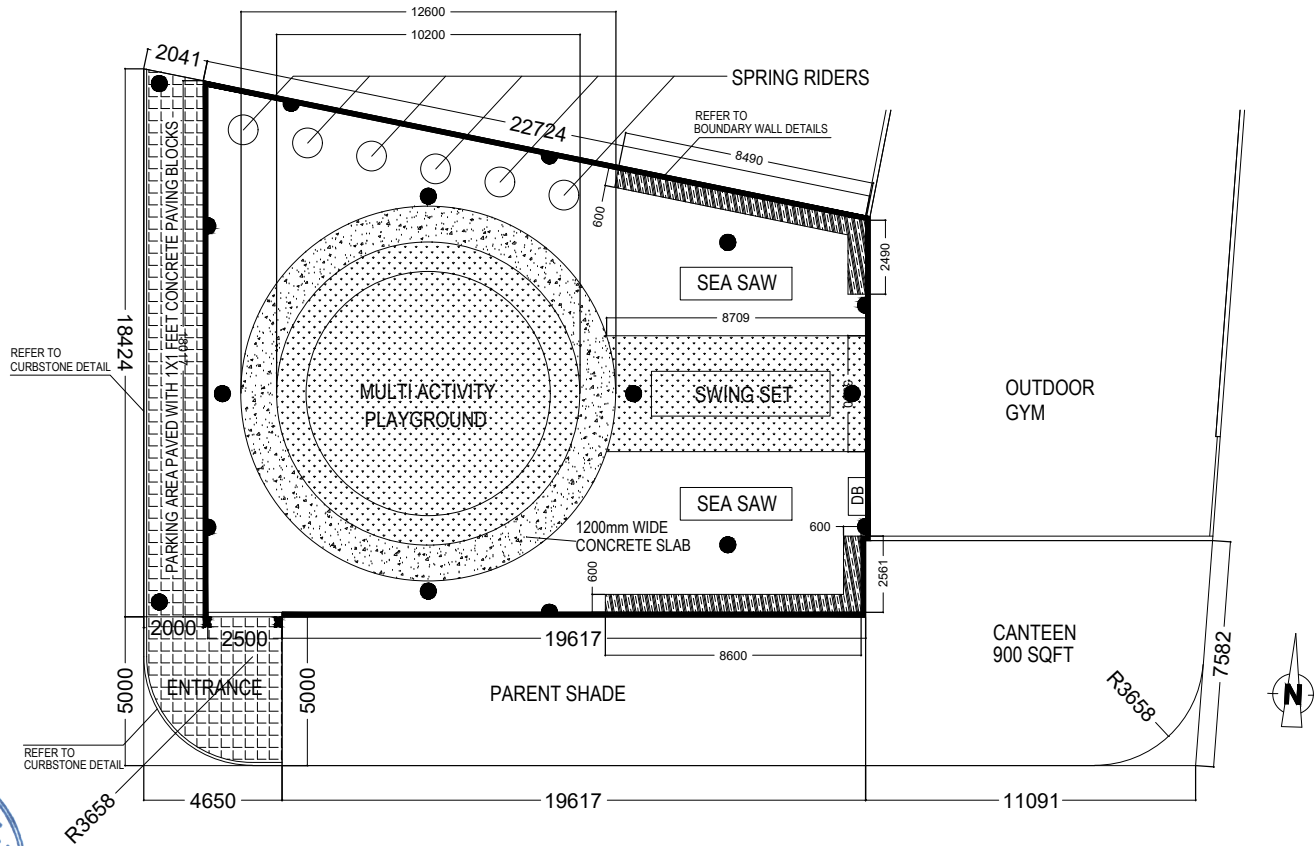

Secretariat of the Faadhippolhu Naifaru Council Faadhippolhu Naifaru , Republic of Maldives		ދުވަހުގެ ސަރުކާރުގެ ސަރުކާރުގެ ސަރުކާރު ދުވަހުގެ ސަރުކާރުގެ ސަރުކާރުގެ ސަރުކާރު	DESIGN:	Ismail Yamaan Yoosuf
			DRAWN BY:	Ismail Yamaan Yoosuf
			PROJECT:	OUTDOOR GYM & PARK
			DATE:	06- 12- 2023

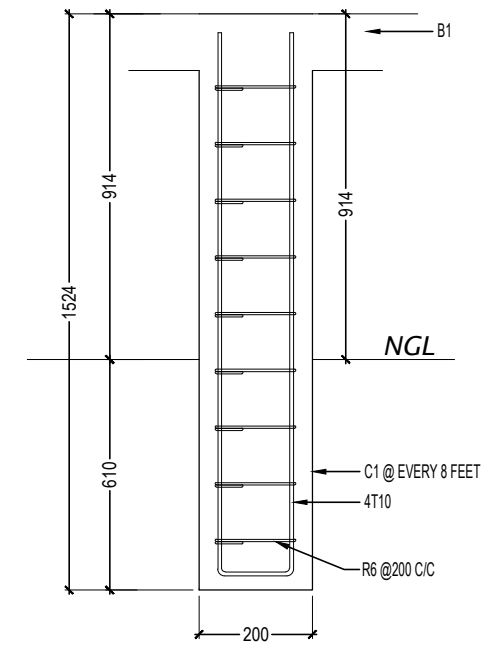
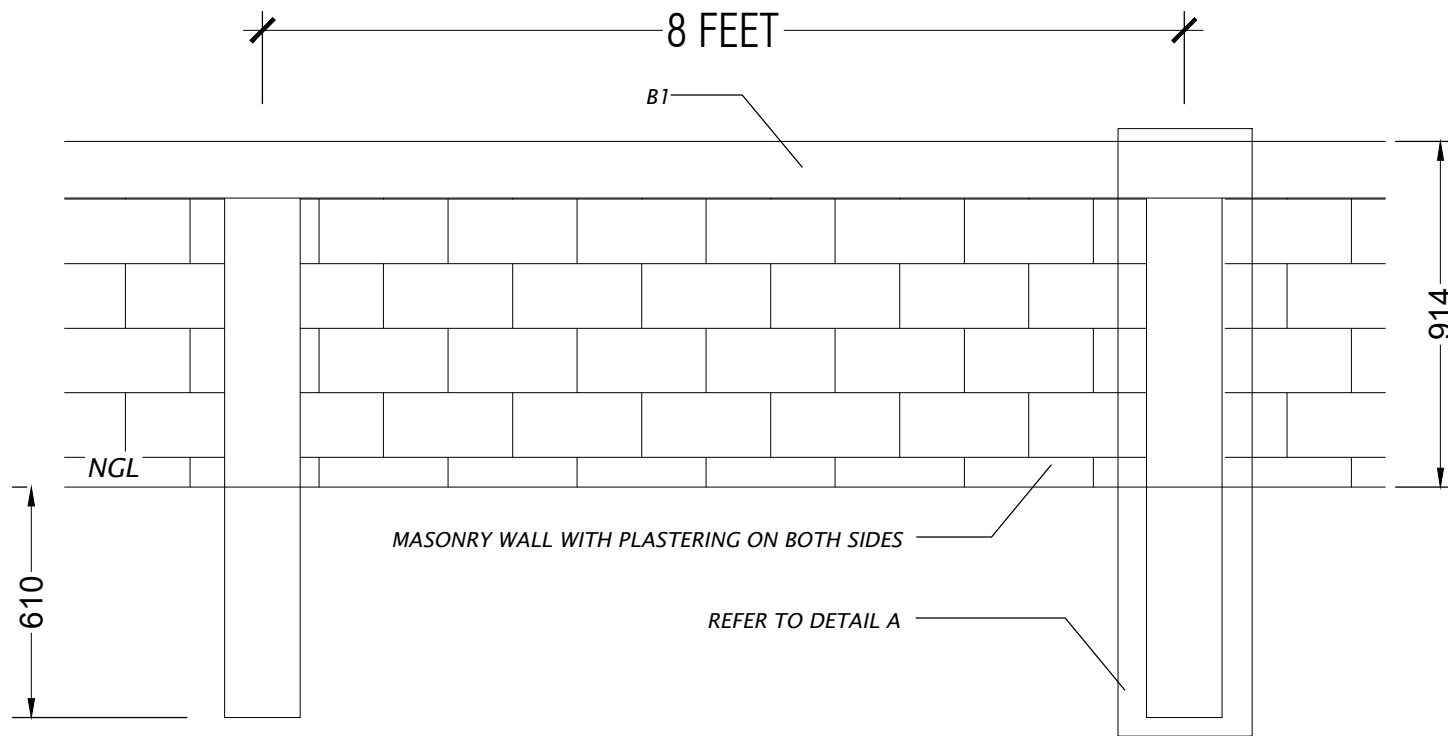

*CHECK ALL MEASUREMENTS ON SITE BEFORE FABRICATION

BOUNDARY WALL DETAIL

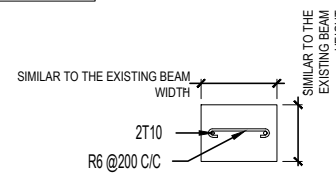

*CHECK ALL MEASUREMENTS ON SITE BEFORE FABRICATION

B1



DESIGN:	Ismail Yamaan Yoosuf
DRAWN BY:	Ismail Yamaan Yoosuf
PROJECT:	OUTDOOR GYM & PARK
DATE:	06- 12- 2023

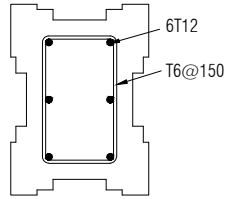

C1

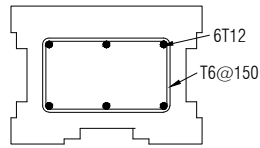

B1

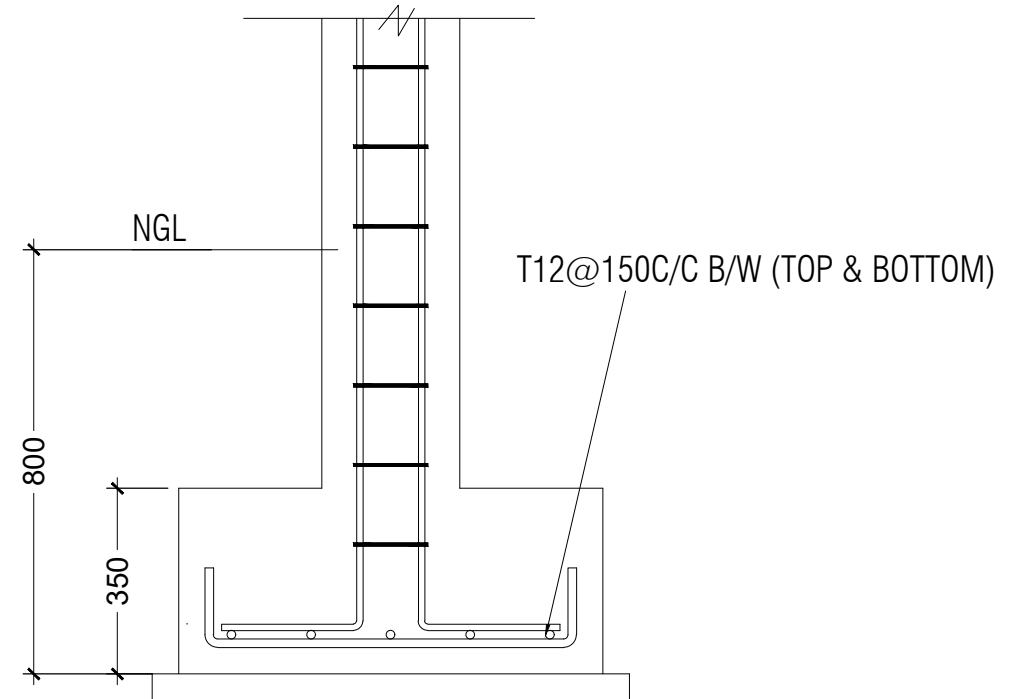
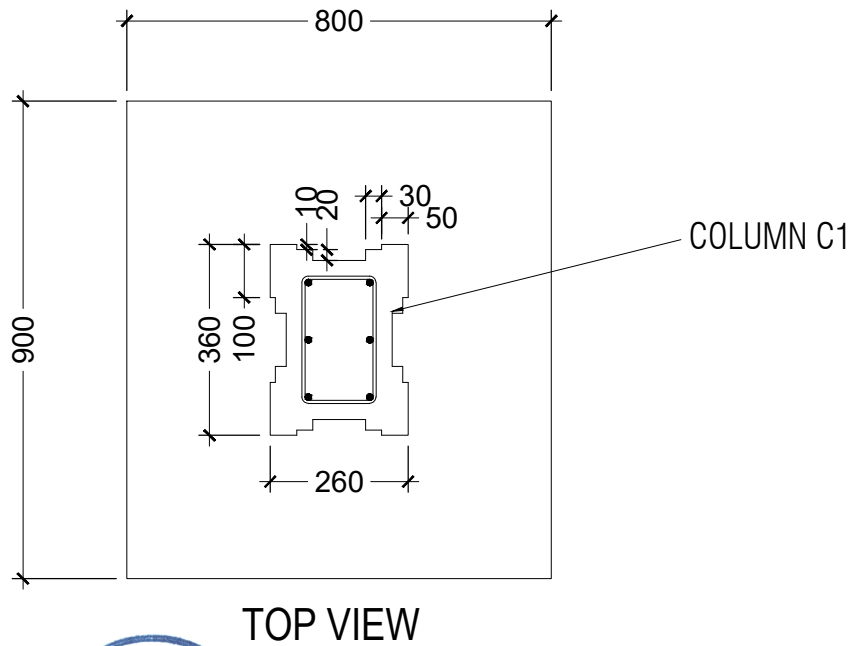

GATE FOUNDATION DETAIL



2 2020

2020 2020 2020



lhnaifarucouncil



www.naifaru.gov.mv



info@naifaru.gov.mv



6620068

1 - 1

1 - 1

#	1	2
1 - 1		
1	✓	1 - 1
2	✓	2 - 1
3		3 - 1
4		4 - 1
5	✓	5 - 1
6	✓	6 - 1
7		7 - 1
8	✓	8 - 1
9		9 - 1
10		10 - 1
1 - 2		
11		11 - 1
12		12 - 1
13		13 - 1
1 - 3		
14		14 - 1
15		15 - 1
16		16 - 1
17		17 - 1
1 - 4		
18		18 - 1
19		19 - 1



4 ޖަވާބު

މި ސަރަޖުގެ ބައި ފުރިހަމަކުރުމަށް

ސަލާމަތުގެ ސަރަޖުގެ ބައި ފުރިހަމަކުރުމަށް			
ނަންބަރު (ސަރަޖުގެ ބައި ފުރިހަމަކުރުމަށް)	ސަރަޖުގެ ބައި	ސަރަޖުގެ ބައި	#
			1
			2
			3
			4
			5
ޖަވާބު			

ސަލާމަތުގެ ސަރަޖުގެ ބައި ފުރިހަމަކުރުމަށް

ފޮޓޯ ފޮޓޯ ފޮޓޯ

ނަންބަރު:

މަތީ:

ފޮޓޯ ފޮޓޯ ފޮޓޯ

ނަންބަރު:

ސަލާމަތުގެ ސަރަޖުގެ ބައި ފުރިހަމަކުރުމަށް

ނަންބަރު:

ސަލާމަތުގެ ސަރަޖުގެ ބައި ފުރިހަމަކުރުމަށް

ނަންބަރު:



Form of Tender Security (Bank Guarantee)

The Issuing Bank shall fill in this Bank Guarantee Form in accordance with the instructions indicated.

..... {Bank's Name, and Address of Issuing Branch or Office}

Beneficiary: {Name and Address of Employer}

Date:

TENDER GUARANTEE No.: _____

We have been informed that _____ {name of the Tenderer} (hereinafter called "the Tenderer") has submitted to you its Tender dated _____ (hereinafter called "the Tender") for the execution of _____ {name of contract} under Invitation for Tenders No. _____ ("the IFB").

Furthermore, we understand that, according to your conditions, Tenders must be supported by a Tender guarantee.

At the request of the Tenderer, we _____ {name of Bank} hereby irrevocably undertake to pay you any sum or sums not exceeding in total an amount of _____ [amount in figures] (_____)

[amount in words] upon receipt by us of your first demand in writing accompanied by a written statement stating that the Tenderer is in breach of its obligation(s) under the Tender conditions, because the Tenderer:

(a) has withdrawn its Tender during the period of Tender validity specified by the Tenderer in the Form of Tender; or

(b) having been notified of the acceptance of its Tender by the Employer during the period of Tender validity, (i) fails or refuses to execute the Contract Form, if required, or (ii) fails or refuses to furnish the performance security, in accordance with the ITB.

This guarantee will expire: (a) if the Tenderer is the successful Tenderer, upon our receipt of copies of the contract signed by the Tenderer and the performance security issued to you upon the instruction of the Tenderer; and (b) if the Tenderer is not the successful Tenderer, upon the earlier of (i) our receipt of a copy your notification to the Tenderer of the name of the successful Tenderer; or (ii) {insert date} twenty-eight days after the expiration of the Tenderer's Tender.

Consequently, any demand for payment under this guarantee must be received by us at the office on or before that date.

This guarantee is subject to the Uniform Rules for Demand Guarantees, ICC Publication No. 458

[Signature(s)]



Advance Payment Security

[The bank, as requested by the successful Contractor, shall fill in this form in accordance with the instructions indicated.]

Date: [insert date (as day, month, and year)]

Title of the Procurement: [Insert general title of the procurement]

Procurement Reference No: [insert reference]

[Issuing bank's letterhead]

Beneficiary: [insert legal name and address of Procuring Entity]

ADVANCE PAYMENT GUARANTEE No.: [insert Advance Payment Guarantee no.]

Advance Payment Guarantee No:

We have been informed that [name of the Contractor] (hereinafter called "the Contractor") has entered into Contract No..... [procurement reference number of the Contract], dated [insert day and month], [insert year] with you, for the execution of [name of contract and brief description of Works] (hereinafter called "the Contract").

Furthermore, we understand that, according to the Conditions of the Contract, an advance payment in the sum [name of the currency and amount in figures] 1 (..... [amount in words]) is to be made against an advance payment guarantee.

At the request of the Contractor, we [name of the Bank]. hereby irrevocably undertake to pay you any sum or sums not exceeding in total an amount of [name of the currency and amount in figures] * (..... [amount in words]) upon receipt by us of your first demand in writing accompanied by a written statement stating that the Contractor is in breach of its obligation under the Contract because the Contractor used the advance payment for purposes other than the costs of mobilization in respect of the Works.

It is a condition for any claim and payment under this guarantee to be made that the advance payment referred to above must have been received by the Contractor on its account number [Contractor's account number]. at [name and address of the Contractor's Bank].

The maximum amount of this guarantee shall be progressively reduced by the amount of the advance payment repaid by the Contractor as indicated in copies of interim statements or payment certificates which shall be presented to us. This guarantee shall expire, at the latest, upon our receipt of a copy of the interim payment certificate indicating that eighty (80) percent of the Contract Price has been certified for payment, or on the day of 2, whichever is earlier. Consequently, any demand for payment under this guarantee must be received by us at this office on or before that date. The Guarantor agrees to a one-time extension of this guarantee for a period not to exceed [six months] [one year], in response to the Employer's written request for such extension, such request to be presented to the Guarantor before the expiry of the guarantee.

This guarantee is subject to the Uniform Rules for Demand Guarantees, ICC Publication No. 458.

..... [Seal of Bank and Signature(s)]

Note:

All italicized text is for guidance in preparing this demand guarantee and shall be deleted from the final document.

1 The Guarantor shall insert an amount representing the amount of the advance payment denominated either in the currency(ies) of the advance payment as specified in the Contract, or in a freely convertible currency acceptable to the Employer.

2 Insert the expected expiration date of the Time for Completion. The Employer should note that in the event of an extension of the time for completion of the Contract, the Employer would need to request an extension of this guarantee from the Guarantor. Such request must be in writing and must be made prior to the expiration date established in the guarantee.

