

Information Sheet for supply of transformers, transformer accessories and ACB Panel

Section A

a) Bid Information

#	Description	Quantity
1	TRANSFORMER 500KVA (PACKAGE SUBSTATION)	02Nos
2	ACB Breaker Panel 2500	01 Nos

Quotation shall indicate the following;

a) Price

- The bidder shall quote for door step delivery value to Male' port
- All items shall be quoted in the bid, please refer section (b) specifications
- Bidder shall quote for 02 person travelling and accommodation chargers in the bid for factory testing
- Quotation shall indicate the unit price, total price for each item and total price of the quotation. The quotation shall separately indicate additional charges such as freight charges, insurance, taxes, etc.

b) Delivery Period

- The delivery period shall be stated in 'calendar days'.
- If the delivery period indicates 'ex-stock', or if the duration is not specified, it shall be taken same as the party offering the longest delivery period.

c) Payment Terms

- The payment terms shall be stated in 'days or months', and the payments will be released in equal monthly instalments.
- No points will be given for payment terms if the bidder requests for Letter of Credit (LC).



- A maximum of 15% of the entire project can be provided as an advance if requested in the bid, however, it cannot be tied to the project starting date.
- For 15% advance bid awarded party has to submit bank guarantee letter along with performer invoice.

d) Technical Specifications

- All the relevant information including the brand shall be given to enable technical evaluation of the items quoted.
- Technical compliance letter will be required to enable technical evaluation
- Transformers and Transformers accessories should comply our requirements, if not the bid will be rejected

e) Factory Testing:

- The Transformer and accessories should be fully tested at the manufacturer workshop in the presence of client's appointees to check the ratings, overload, functional tests on a dummy load prior to dispatch. The testing shall be conducted to internationally accept testing standards. The bidder shall arrange airfare, transportation, accommodation and lodging for two of client's technicians for the testing (minimum of two day for testing)
- 02 engineers from Fenaka Corporation shall carry out necessary inspection and testing of equipment prior to shipment in supplier's warehouse in order to ensure that the equipment has been manufactured in accordance with the contract document.

f) Quotation validity should be a minimum of 60 days from the date of quotation opening.

g) Bid Security validity is valid for Twenty (20) days beyond the validity of the bid

Note: It is in FENAKA Corporation Limited's discretion to reject/cancel any quotation which does not fulfil or comply the above terms.

بِسْمِ اللّٰهِ الرَّحْمٰنِ الرَّحِیْمِ



Section B

ފެނާކާ ޕްރޮޕްރިއެޓީޕްރިލިމިޓްޑް
ދިވެހިރާއްޖެ

Specifications

a) Specification of 500KVA Transformers

500kVA Power Transformer (Quantity:02)
General information
<p>Climatic Conditions Materials supplied shall be suitable for operating under the following climatic conditions</p> <p>Climate : Typical tropical coast line. Atmosphere : Saliferous, corrosive and dusty. Altitude : 2 meter above mean sea water level. Temperature : 32 °C (mean maximum) 25 °C (mean minimum). Barometric air pressure: 1010 millibars. Relative humidity : 90%. Average rainfall : 145 days/year. Average sunshine : 24 days/month. Mean wind speed : 10.8 knots. Maximum wind speed : 15.1 knots.</p> <p>Equipment must withstand worst tropical conditions, including lightning, cyclonic rains, and high humidity.</p>
A) Step-Down Transformer 11kV/415V, 500kVA
<p>3 phase 50Hz 500kVA Dyn11, core type double wound with copper conductor, mineral oil immersed ONAN cooled distribution transformer with corrugated tank & conservator arrangement having a no load voltage ratio of 11/0.433 KV. Tappings +5% to -5% in steps of 2.5% shall be provided at line end of HV winding. Changing of taps shall be carried out by means of OFF Load Tap Changer.</p>
<p>Temperature rise shall be 50/60 °C in oil/winding respectively over a maximum ambient of 40°C. The transformer shall be manufactured as per latest IEC.</p>
HV Insulation Level 12kV
Power frequency 28kV. r.m.s.
Basic Impulse Level 75kV. Peak.
HV/LV Connection Delta/ Star N. pt
Dial type thermometer with contacts and control box for relays.
level indicator and pressure relief valve and oil drain valve.
Hermetically sealed without gas cushion.
Relevant testing standards : IEC / BS standards.

B) Separate LV Panel for Transformer
Free standing LV Panel with 1200A, PVC sleeved Cu busbar, complete With measuring, indication and protection(ELR).
Incoming
1 Nos x 800A ACB motorized - main circuit breaker
Outgoing
1 Nos x Outgoing feeder with 630A MCCB
2 Nos x Outgoing feeder with 400A MCCB
5 Nos x Outgoing feeder with 200A MCCB
Bottom entry Cable Termination arrangement.
C) 1Nos x 3 Way Non Extensible Unit with 2 Nos. Isolators as Incomers and 1 No. Circuit Breaker as Outgoing to 500kVA Transformer ((TYPE Ringmaster : Merlin Gerin RM6 NE-IIDI or equivalent)
3 Way, 11kV, indoor extensible free standing metal clad SF6 insulated ring main unit comprising of three numbers 630A fault making/ load breaking switches and one number 200A tee-off circuit breakers complete with all necessary measurement and protection devices.

b) Specification of ACB Breaker Panel 2500AMP

SPECIFICATION FOR AIR CIRCUIT BREAKER PANEL (Qty:01)

- Free standing Breaker Panel as per the attached drawing consisting of
 - 1Nos x 3000A TPN motorized Air Circuit Breaker (brand: Schneider, ABB or equivalent), rated at 600/1000V complete with 240 Volt under Voltage Trip Coil and auxiliary switches.
 - 6000A TPN Tin/Copper coated copper busbar suitably braced for 30-80kA one second fault ratings.
 - Indicating Lights
 - o 1 set x indicating lights for incoming (R,Y,B)
 - o 1 set x indicating lights for outgoing (R,Y,B)
 - o ACB ON/OFF LED Indicators (Red/Green)
 - Measuring and Protection Devices
 - o 1 nos x Overcurrent Relay, brand : Delab or equivalent
 - o 1 nos x Earth Leakage Relay, brand : Delab or equivalent
 - o 3 nos x Analogue Ampere Meters 0-3000A (one for each phase –R,Y,B)
 - o Multifunctional Digital meter capable of measuring
 - Voltage (0-500V) – shall display Line-to-Line and Line-to-neutral voltages
 - Phase Ampere (0-3000A) – shall measure the phase currents.
 - Frequency (40- 65Hz) – generator frequency measurement

- Power , kW – shall display power of L1, L2, L3 and total power
 - Power factor, shall display p.f of L1, L2, L3 and average.
- 2Nos x 4 Way Termination blocks for 630sqmm Cable (incoming and outgoing)
- Enclosure : Free standing manufactured using high quality galvanised MS Plates powder coated with epoxy resin to withstand high saline and high temperature weather conditions. Enclosure shall be of Bottom cable entry type.
- The panel dimensions shall meet or be similar to the given minimum dimensions (2055 X 660 X 880 mm). Please refer to the drawing attached
 - Busbar shall be arranged at the back of the cubicles and must be made of hard drain high conductivity copper which meets with relevant BS and IEC Standard
 - The panel shall be manufactured using high quality electro galvanized MS plates of atleast 1.6mm thickness, treated and powder coated upto 80 micron or higher.
 - The panel internal wiring shall be wired using 2.5sqmm thick flexible copper cables. All the wires shall be properly labelled and terminated with suitable terminal.
 - Components such as relays, isolators, switches ,meters and instruments shall be from reputable brands and shall fully comply with relevant international standards.
 - A single line diagram must be provided together with technical specification of the main components of the panel

Drawing

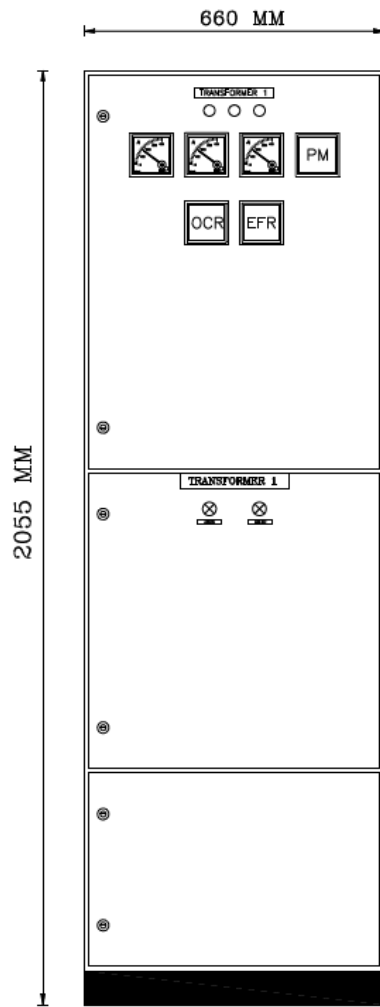
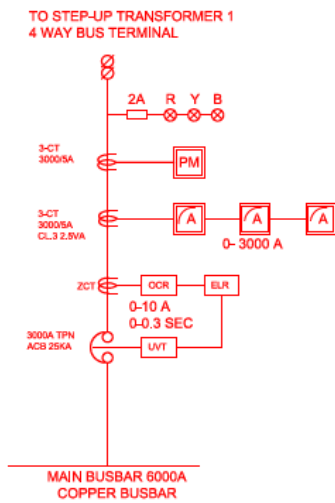

Depth: 880mm

بِسْمِ اللّٰهِ الرَّحْمٰنِ الرَّحِیْمِ



Section C

ފެނާކާ ޕްރޮޕްޔެރްޓީޕްރޮޖެކްޓްޕްރޮޖެކްޓް
ޕްރޮޖެކްޓްޕްރޮޖެކްޓް

Required Document and Evaluation criteria



Required Documents

- Quotation (inclusive of the delivery period and the payment terms)
- 3 set of the bid (One Original and 2 copy set) separately packed and sealed with company stamp. All the pages in bid documents should be stamped.
- Specification of the offered product
- Bid Security (As per Announcement), Original
- Related Experience Letter of past 5 years.
- Details of the company
 - Company profile (This should include the list of board of Directors of company and background of the company with the products they supply)
 - Company registration certificate
 - GST registration certificate (For local suppliers only)
 - Contact details (Name, Designation, Mobile number and Email)

Important Note:

- Bids lacking the documents above are subjected to be rejected during bid opening. Also it is in FENAKA's discretion to cancel this invitation to bid at any time.
- Bidders can submit maximum of 2 options.

Evaluation Criteria

- **Proposal Cost:** 40 points
 - (Lowest proposed price / proposed price) x 40 points
- **Delivery:** 30 Point
 - (Shortest Delivery Period) / (Quoted Delivery Period) x 30
- **Payment Terms:** 20 points for the maximum days given for payment
 - (Proposed credit period / longest credit period) x 20
- **Experience** 10 points (Point will be given by analyzing Related Experience letters of past 5 years depending on the value of the project)

بِسْمِ اللّٰهِ الرَّحْمٰنِ الرَّحِیْمِ



ފެނަކާ ޕޯޓް ކޮމްޕްލެކްސް ބިލްޑިންގ
ޕްލާން ޕްރޮޖެކްޓް

Please submit your bids by 21st March 2019, Thursday 12:30pm. (Maldivian time), addressed to;

Tender Ref No: FNK-I/IUL/2019/058

Managing Director

Fenaka Corporation Ltd

Port Complex Building, 7th Floor

Hilaalee Magu, Maafannu

K. Male'

The proposal and the envelope must bear the reference number of the tender. All envelopes must be duly sealed and stamped. Fenaka Corporation will not be liable for the misplacement or premature opening of unlabelled sealed proposals. The bids will be opened on 21st March 2019, Thursday 12:30pm. (Maldivian time), in the presence of the bidders. The bids received after the stated time, and the bids received via email will not be accepted.

For more information and clarifications, please email us at tender@fenaka.com.mv

10th March 2019