

ދިވެހިސަރުކާރުގެ ގެޒެޓް 1

Gate

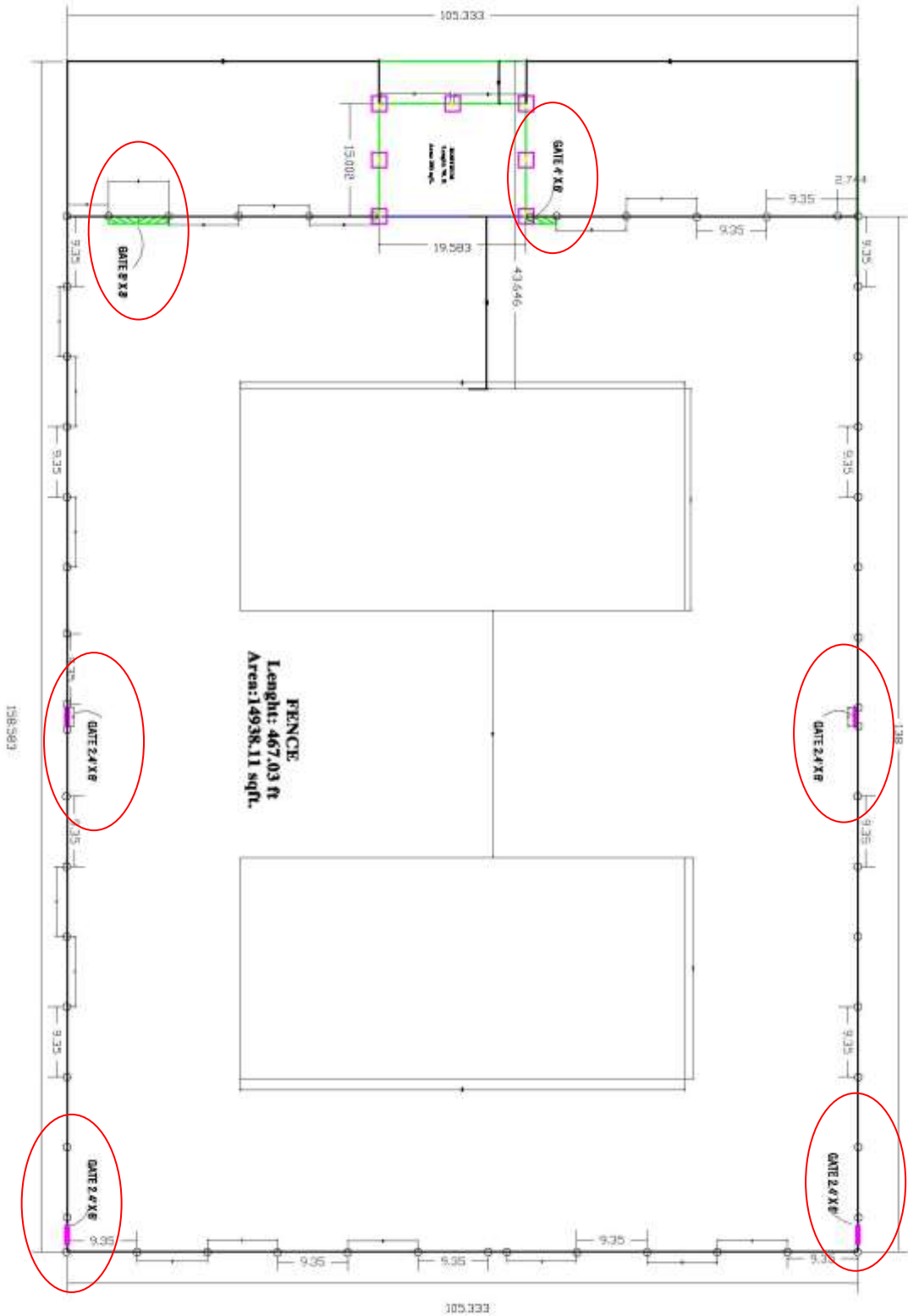

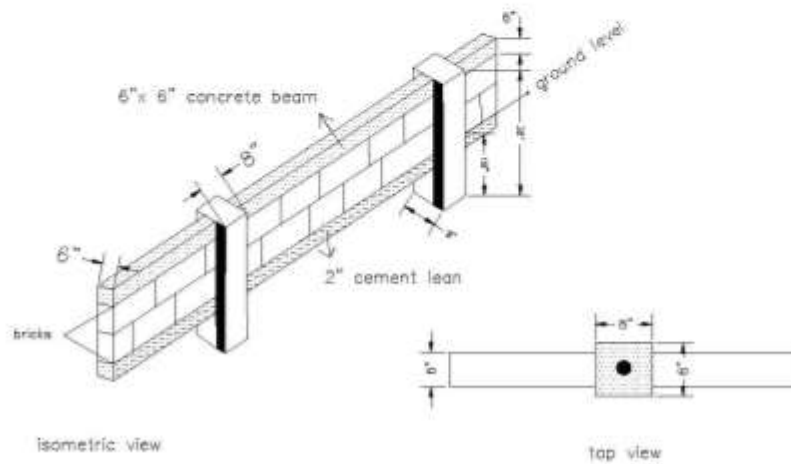
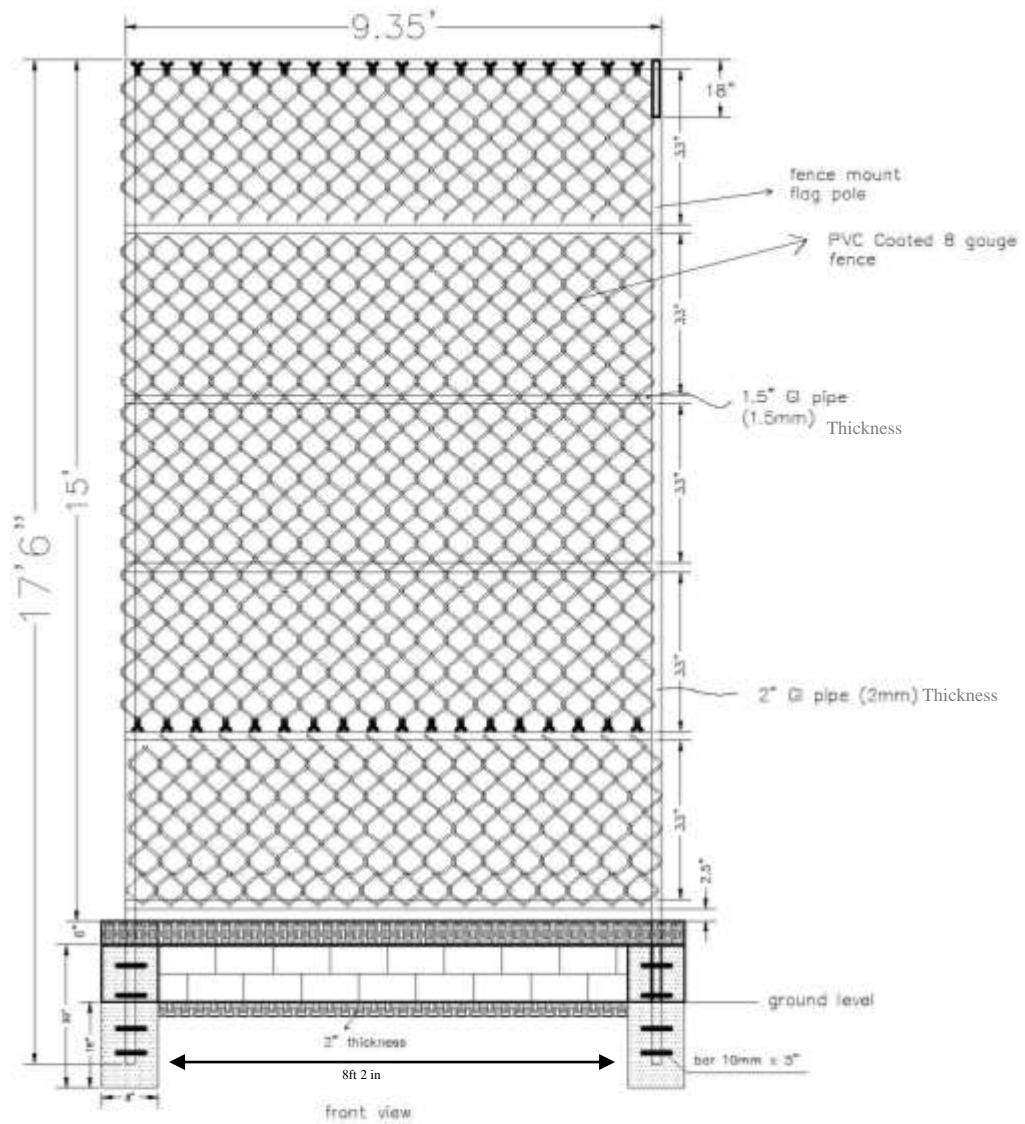

މަތީ ބައިގެ ޖެނެރެޝަން ޖަހާ ޖެނެރެޝަން

❖ GI square pipe 2mm thick

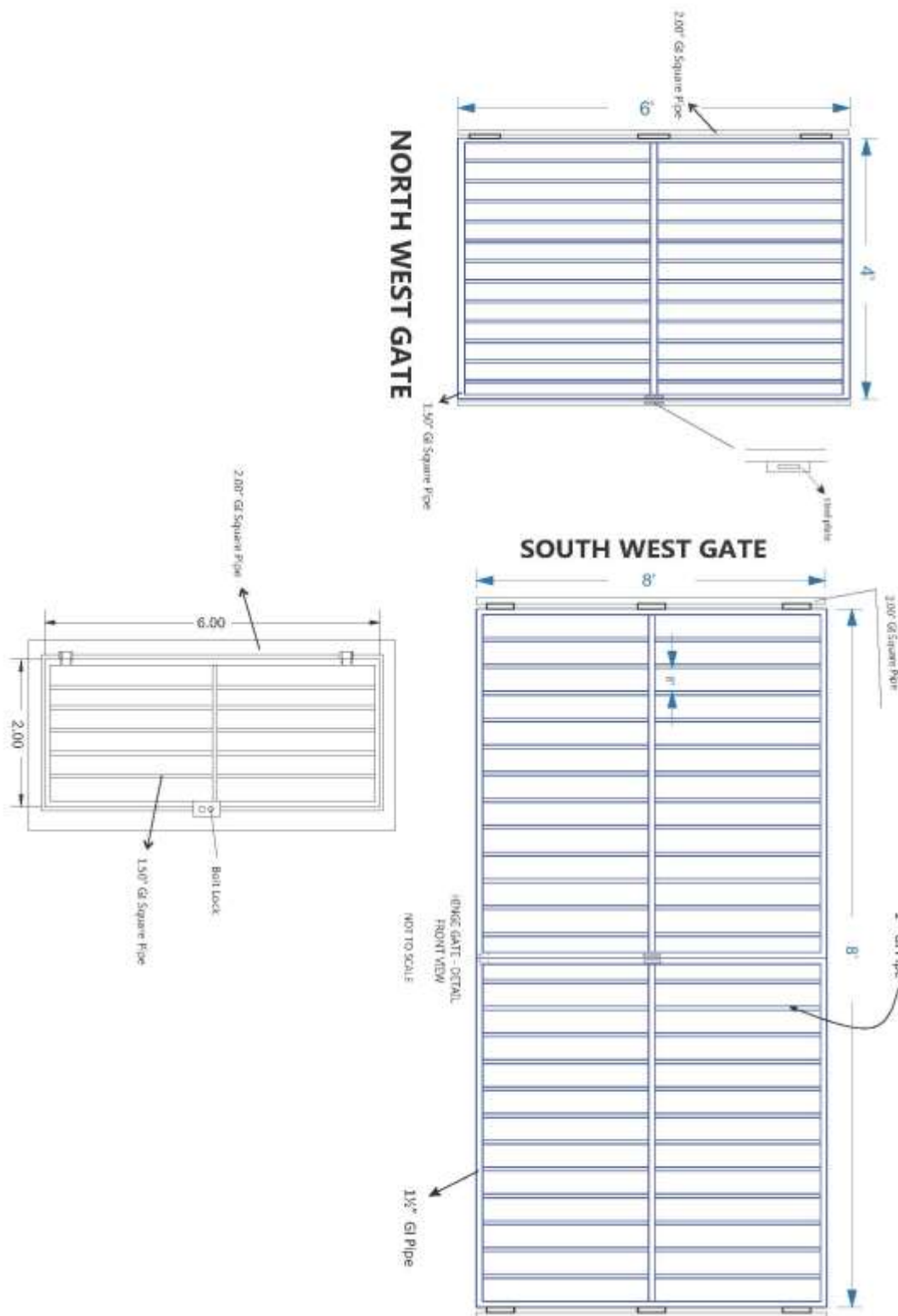

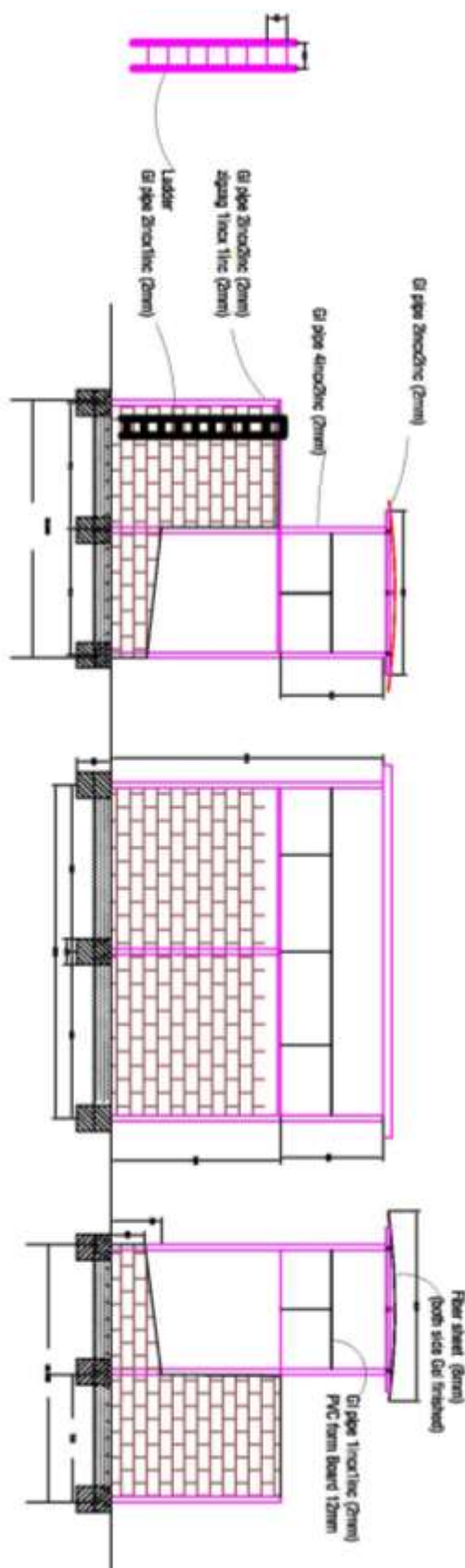

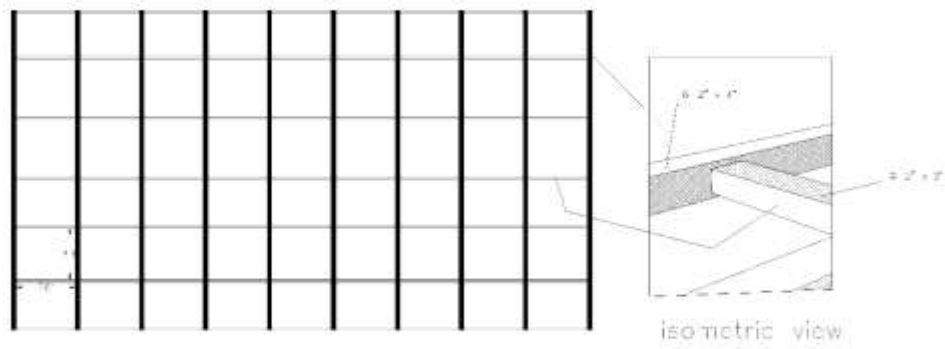
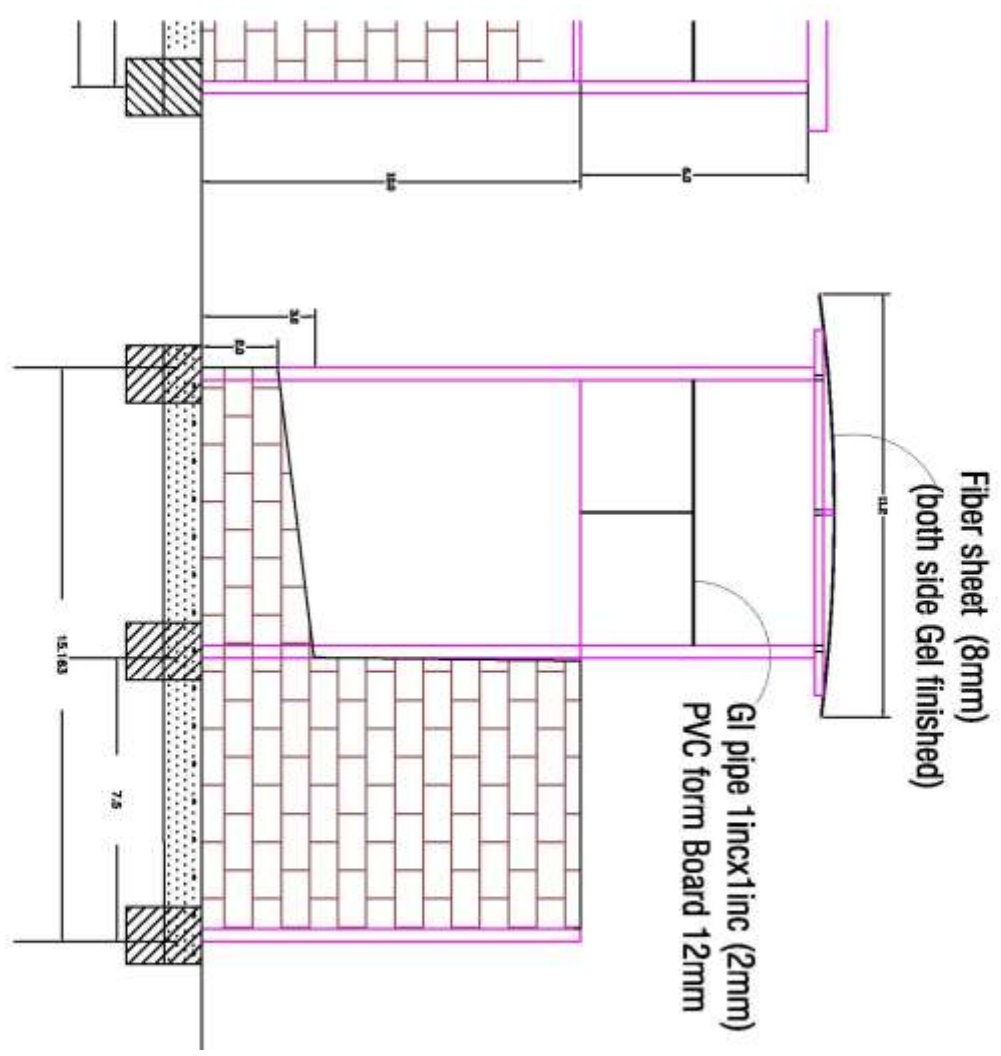

Annex 4 -sheet metal structure (top view)



ދިވެހިސަރުކާރުގެ ގެޒެޓް ގައި ބަޔާންކޮށްފައިވާ ގޮތުގައި

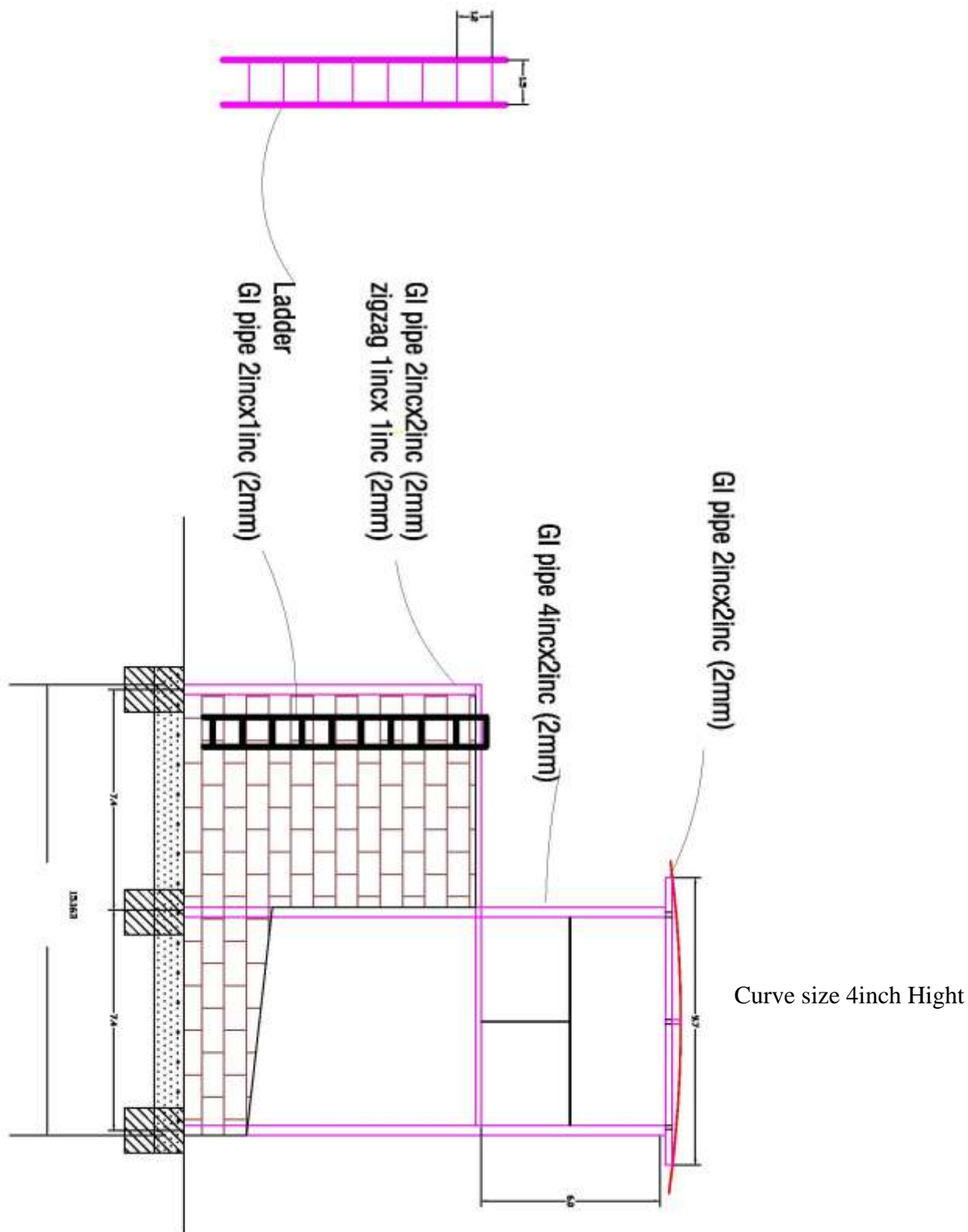

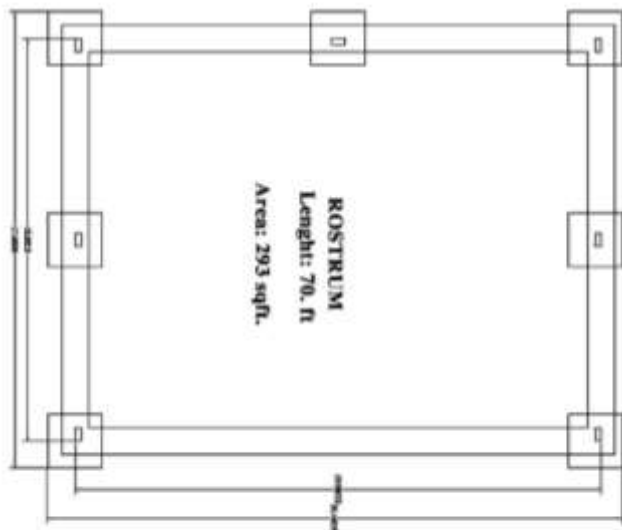
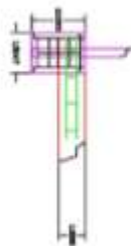

top view column and foundation

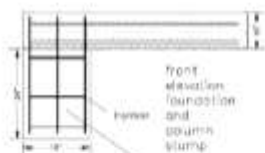

front elevation foundation and column slump

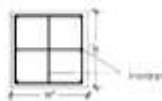

reinforced column slump top view

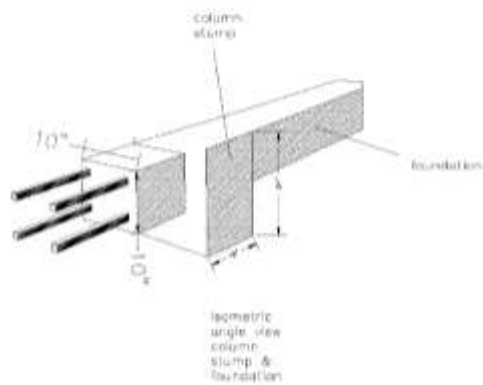

isometric angle view column slump & foundation



ޖަނަވީ ފަރާތްތަކުގެ ނަންބަރު

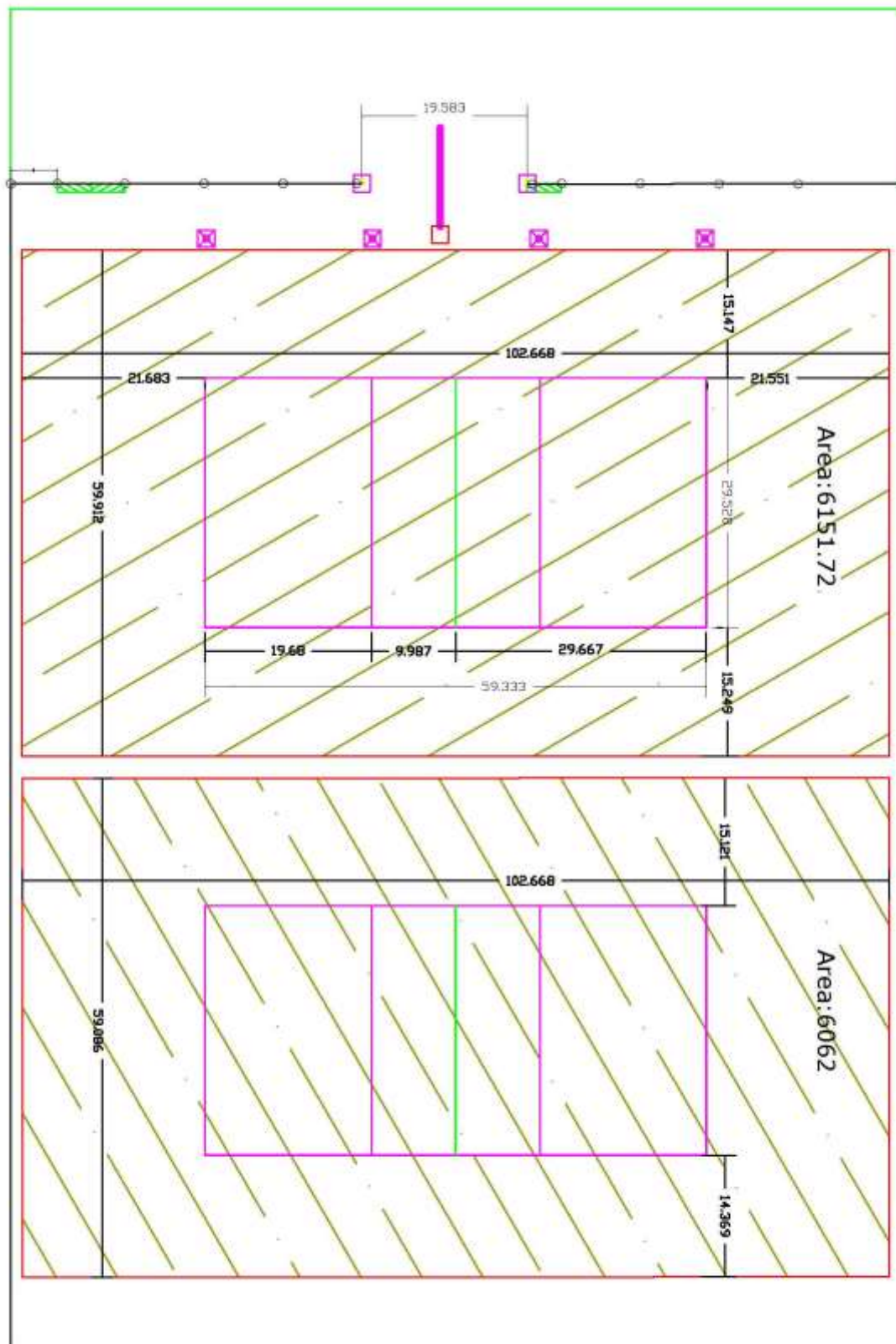



ފަތް ސަލާމަތު (މަޢުލޫމާތު)

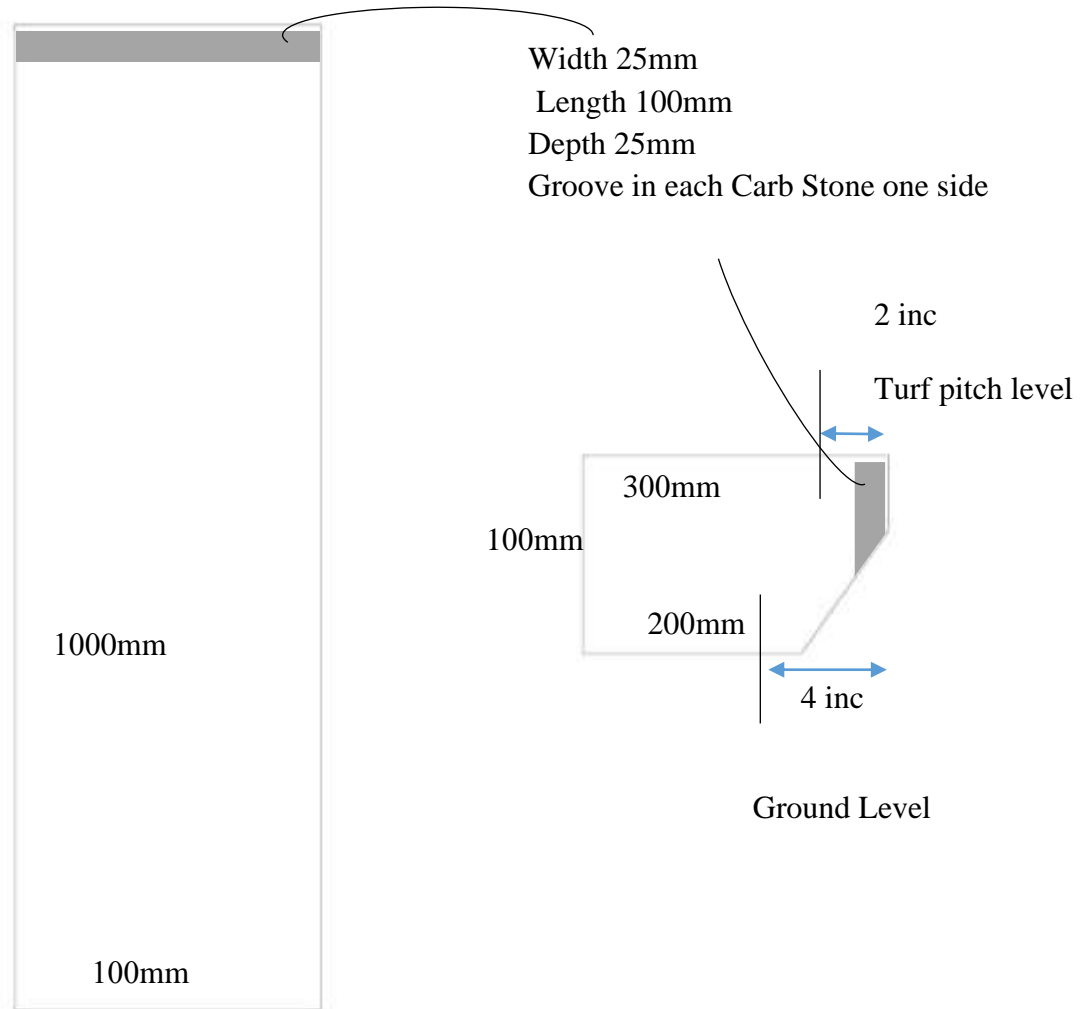

މަނިކުފުތު ވަގުދު ޖެނެރަލް ސެކްޝަން / ފަންޓު ސެކްޝަން / ފަންޓު ސެކްޝަން ޖެނެރަލް ސެކްޝަން

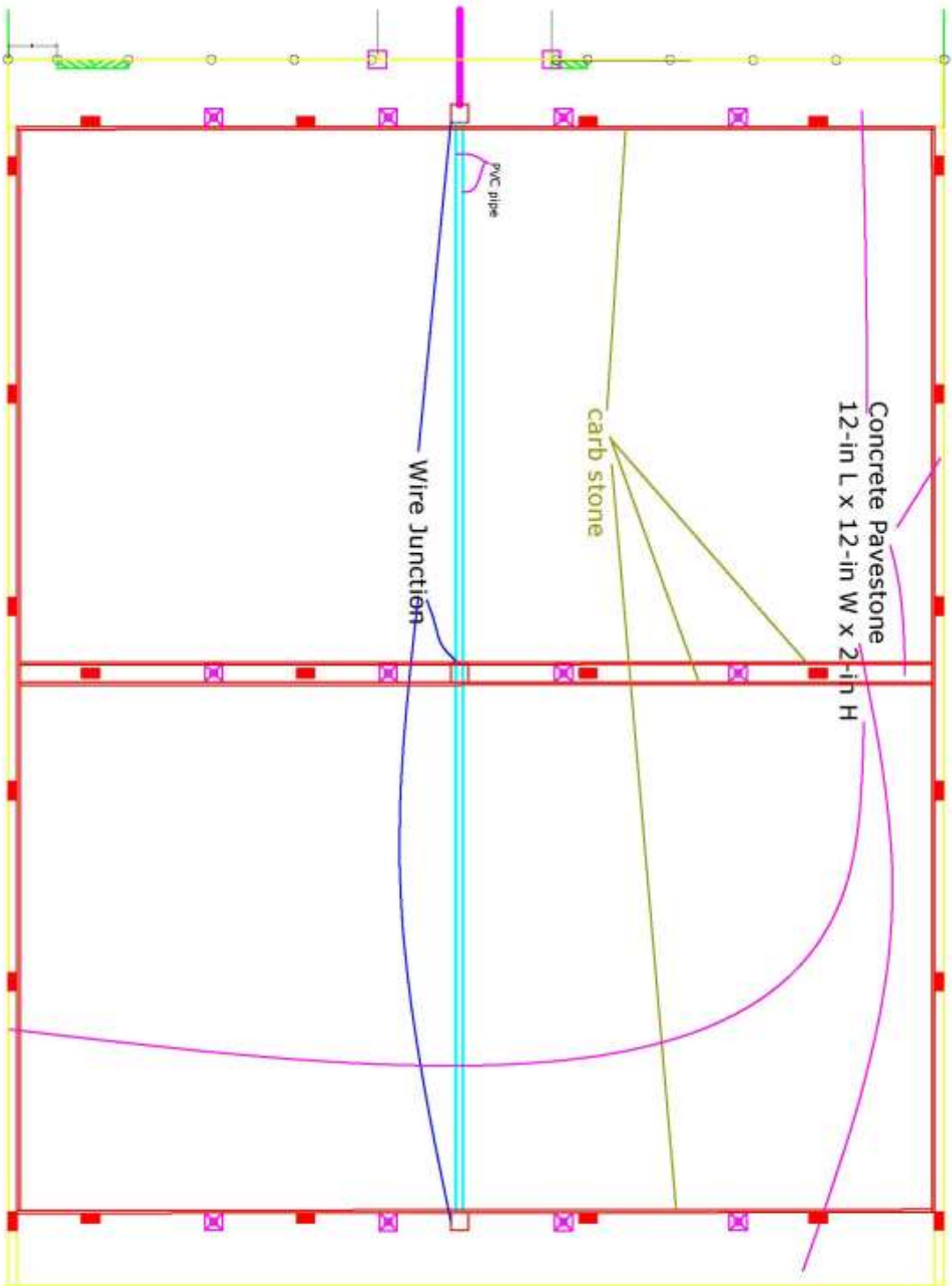

375 375 2

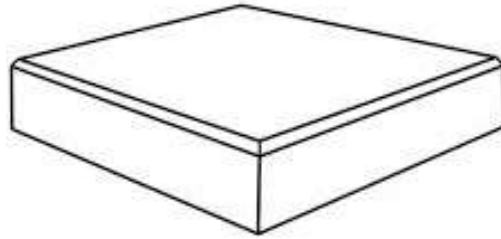

Length: 12inch  
Width: 12inch  
Thick: 2inch

9

GI bench as per drawings.

Rates shall include fabrication painting and completion of all necessary works



PORTABLE PLAYER BENCH  
PLAN VIEW  
SCALE: 1:10



PORTABLE PLAYER BENCH  
FRONT VIEW  
SCALE: 1:10

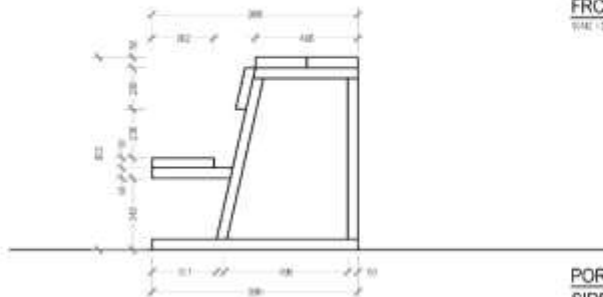

PORTABLE PLAYER BENCH  
SIDE VIEW  
SCALE: 1:10



## GUT-CVR TECHNICAL DATA SHEET

### RCC Settlement Tank Cover

MRDC's engineering quality cement concrete products (MRDC Blocks) are durable, high strength bricks, specially manufactured to cope with exposure to abrasive conditions. This can be used in the gutter line to cover the gutter line.

#### Settlement Tank Cover Specification

Form	RCC grating gutter cover
Appearance	Standard gray colour - untreated surface
Size	1000mm x 400mm x 500mm and 80mm thickness
Composition	OPC + River sand + Aggregates
Density	Average 2587.6kg/m <sup>3</sup>
Dry Weight	90kg approximately
Strength	Average 19.0N/mm <sup>2</sup>
Surface treatment	Untreated
Area coverage	N/A
Presentation	Pellet containing 30 Nos
Pack Weight	2715kg approximately including pellet
Approx Pack Dimension	1.0m x 1.0m x 1.0m height approximately

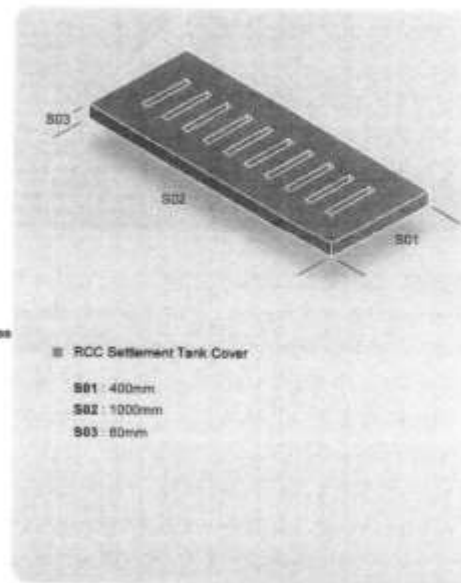

#### Annex 9

## SETT-T TECHNICAL DATA SHEET

### Settlement Tank

MRDC's engineering quality cement concrete products (MRDC Blocks) are durable, high strength bricks, specially manufactured to cope with exposure to abrasive conditions.

This can be used to collect water from gutter line.

#### Settlement Tank Specification

Form	Solid PCC settlement tank
Appearance	Standard gray colour - untreated surface
Size	1000mm x 400mm x 800mm and 80mm thickness
Composition	OPC + coral sand + coral stone
Density	Average 2174.9kg/m <sup>3</sup>
Dry Weight	330kg approximately
Strength	Average 13.8N/mm <sup>2</sup>
Surface treatment	Untreated
Area coverage	N/A
Presentation	Pellet containing 5 Nos
Pack Weight	1665kg approximately including pellet
Approx Pack Dimension	1.0m x 1.0m x 1.0m height approximately

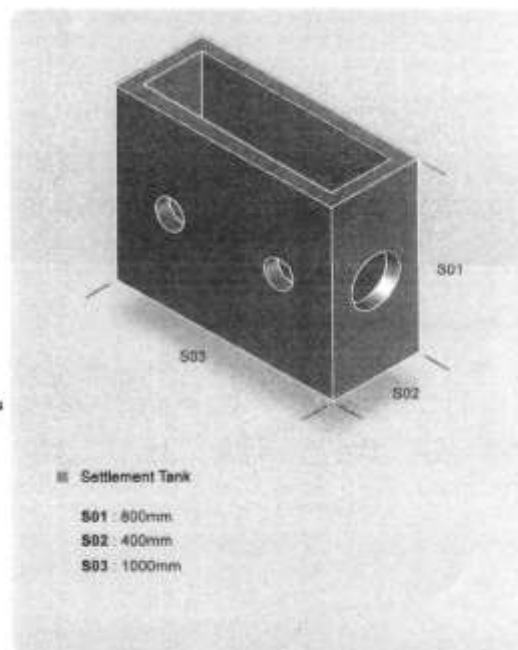

**Form of Performance Bank Guarantee  
(Unconditional)**

To: ..... [name & address of Purchaser]

WHEREAS ..... [name and address of Supplier] (hereinafter called “the Supplier”) has undertaken, in pursuance of Contract No. .... dated ..... to execute ..... [name of Contract and brief description of Works] (hereinafter called “the Contract”). AND WHEREAS it has been stipulated by you in the said Contract that the Supplier shall furnish you with a Bank Guarantee by a recognized bank for the sum specified therein as security for compliance with his obligations in accordance with the Contract. AND WHEREAS we have agreed to give the Supplier such a Bank Guarantee. NOW THEREFORE we hereby affirm that we are the Guarantor and responsible to you, on behalf of the Supplier, up to a total of \*..... [amount of Guarantee] ..... [amount in words], such sum being payable in the types and proportions of currencies in which the Contract Price is payable, and we undertake to pay you, upon your first written demand and without cavil or argument, any sum or sums within the limits of ..... [amount of Guarantee] as aforesaid without your needing to prove or to show grounds or reasons for your demand for the sum specified therein.

\*An amount is to be inserted by the Guarantor, representing the percentage of the Contract Price specified in the Contract, in Maldivian Rufiyaa.

We hereby waive the necessity of your demanding the said debt from the Supplier before presenting us with the demand. We further agree that no change or addition to or other modification of the terms of the Contract or of the Works to be performed there under or of any of the Contract documents which may be made between you and the Supplier shall in any way release us from any liability under this Guarantee, and we hereby waive notice of any such change, addition, or modification. This Guarantee shall be valid until the date of issue of the Defects Correction Certificate.

SIGNATURE AND SEAL OF THE GUARANTOR .....

Name of Bank .....

Address .....

Date .....



Form of Bid Security (Bank Guarantee)

WHEREAS ..... [name of Bidder] (hereinafter called “the Bidder”) has submitted his Bid for the Tender no..... issued by the Secretariat of the Alifushi Council on ..... for Supplying/Purchasing of ..... [name of Contract] (hereinafter called “the Bid”). KNOW ALL PEOPLE by these presents that We..... [name of Bank] of ..... [name of country] having our registered office at ..... (Hereinafter called “the Bank”) are bound unto ..... [name of Purchaser] (hereinafter called “the Purchaser”) in the sum of \*..... for which payment well and truly is to be made to the said Purchaser, the Bank binds itself, its successors, and assigns by these presents. SEALED with the Common Seal of the said Bank this ..... day of .....20.....

THE CONDITIONS of this obligation are:

- (1) If, after Bid opening, the Bidder withdraws his Bid during the period of Bid validity specified in the Form of Bid; or
- (2) If the Bidder having been notified of the acceptance of his Bid by the Purchaser during the period of Bid validity:
  - (a) Fails or refuses to execute the Form of Agreement in accordance with the Instructions to Bidders, if required; or
  - (b) Fails or refuses to furnish the Performance Security, in accordance with the Instruction to Bidders; or
  - (c) Does not accept the correction of the Bid Price pursuant to Clause 8,

\*The Bidder should insert the amount of the Guarantee in words and figures denominated in Maldivian Rufiyaa. This figure should be the same as shown in Clause 9.1 of the Instructions to Bidders

We undertake to pay to the Purchaser up to the above amount upon receipt of his first written demand, without the Purchaser’s having to substantiate his demand, provided that in his demand the Purchaser will note that the amount claimed by him is due to him owing to the occurrence of one or any of the three conditions, specifying the occurred condition or conditions. This Guarantee will remain in force up to and including the date ..... days after the deadline for submission of bids as such deadline is stated in the Instructions to Bidders or as it may be extended by the Purchaser, notice of which extension(s) to the Bank is hereby waived. Any demand in respect of this Guarantee should reach the Bank not later than the above date.

DATE.....

SIGNATURE OF THE BANK:

WITNESS .....

SEAL

[signature, name, and address]



<p>                     ބަނޑު 1                      ދަނޑު 1                      ދަނޑު 1                      ދަނޑު 1                 </p>	<p>                     ދަނޑު 1                      ދަނޑު 1                 </p>	<p>#</p>
	<p>                     ދަނޑު 1                 </p>	<p>1</p>
	<p>                     ދަނޑު 1                 </p>	<p>2</p>
	<p>                     ދަނޑު 1                      ދަނޑު 1                 </p>	<p>3</p>
	<p>                     ދަނޑު 1                 </p>	<p>4</p>
<p>                     ދަނޑު 1                 </p>		

