

بِسْمِ اللّٰهِ الرَّحْمٰنِ الرَّحِیْمِ



مَدْرَسَةُ الْوَعْدِ

مَدْرَسَةُ الْوَعْدِ : مَدْرَسَةُ الْوَعْدِ دَرَجَةُ رَاسِمٍ 2 مَدْرَسَةُ الْوَعْدِ 7 وَسَرِ الْوَعْدِ رَاسِمٍ 4 وَسَرِ الْوَعْدِ رَاسِمٍ
مَدْرَسَةُ الْوَعْدِ رَاسِمٍ، مَدْرَسَةُ الْوَعْدِ رَاسِمٍ دَرَجَةُ رَاسِمٍ

مَدْرَسَةُ الْوَعْدِ رَاسِمٍ : 57-T/IU/2024/38

مَدْرَسَةُ الْوَعْدِ دَرَجَةُ رَاسِمٍ
مَدْرَسَةُ الْوَعْدِ رَاسِمٍ

<p>6.2</p>	<p>የግብርና ስራዎች ለማጠናቀቅ ለማድረግ የሚያስፈልገው የገንዘብ ስጦታ (የግብርና ስራዎች) 500,000 ለገንዘብ ስጦታ ስር ይገኛል።</p>
<p>6.3</p>	<p>የግብርና ስራዎች ለማጠናቀቅ ለማድረግ የሚያስፈልገው የገንዘብ ስጦታ (የግብርና ስራዎች) 7 ለገንዘብ ስጦታ ስር ይገኛል።</p>
<p>6.4</p>	<p>የግብርና ስራዎች ለማጠናቀቅ ለማድረግ የሚያስፈልገው የገንዘብ ስጦታ (የግብርና ስራዎች) 11 ለገንዘብ ስጦታ ስር ይገኛል።</p>
<p>6.5</p>	<p>የግብርና ስራዎች ለማጠናቀቅ ለማድረግ የሚያስፈልገው የገንዘብ ስጦታ (የግብርና ስራዎች) 3 ለገንዘብ ስጦታ ስር ይገኛል።</p>
<p>6.6</p>	<p>የግብርና ስራዎች ለማጠናቀቅ ለማድረግ የሚያስፈልገው የገንዘብ ስጦታ (የግብርና ስራዎች) 3 ለገንዘብ ስጦታ ስር ይገኛል።</p>
<p>6.7</p>	<p>የግብርና ስራዎች ለማጠናቀቅ ለማድረግ የሚያስፈልገው የገንዘብ ስጦታ (የግብርና ስራዎች) 5% ለገንዘብ ስጦታ ስር ይገኛል።</p>
<p>7</p>	<p>የግብርና ስራዎች ለማጠናቀቅ ለማድረግ የሚያስፈልገው የገንዘብ ስጦታ (የግብርና ስራዎች) 10.62 ለገንዘብ ስጦታ ስር ይገኛል።</p>
<p>7.1</p>	<p>የግብርና ስራዎች ለማጠናቀቅ ለማድረግ የሚያስፈልገው የገንዘብ ስጦታ (የግብርና ስራዎች) 10.62 ለገንዘብ ስጦታ ስር ይገኛል።</p>
<p>8</p>	<p>የግብርና ስራዎች ለማጠናቀቅ ለማድረግ የሚያስፈልገው የገንዘብ ስጦታ (የግብርና ስራዎች) 10.65 ለገንዘብ ስጦታ ስር ይገኛል።</p>
<p>8.1</p>	<p>የግብርና ስራዎች ለማጠናቀቅ ለማድረግ የሚያስፈልገው የገንዘብ ስጦታ (የግብርና ስራዎች) 11 ለገንዘብ ስጦታ ስር ይገኛል።</p>
<p>8.2</p>	<p>የግብርና ስራዎች ለማጠናቀቅ ለማድረግ የሚያስፈልገው የገንዘብ ስጦታ (የግብርና ስራዎች) 11.12 ለገንዘብ ስጦታ ስር ይገኛል።</p>
<p>8.3</p>	<p>የግብርና ስራዎች ለማጠናቀቅ ለማድረግ የሚያስፈልገው የገንዘብ ስጦታ (የግብርና ስራዎች) 11.12 ለገንዘብ ስጦታ ስር ይገኛል።</p>

سوال شماره 2 - از طرف حساب داریانان حساب داریانان حساب داریانان

مبلغ	تاریخ ثبت و توضیح	تاریخ ثبت و توضیح
100	(100 × (100 / 100)) (100 × 100)	100
100	بدهی	

*** نکته-1:** در حساب داریانان و حساب داریانان در حساب داریانان. سود و زیان محاسبه و گزارش،
 طبقاً به ماده 5 از قانون ثبت اسناد و املاک (اصولاً در حساب داریانان) در حساب داریانان (اصولاً در حساب داریانان)
 حساب داریانان / حساب داریانان در حساب داریانان (اصولاً در حساب داریانان) حساب داریانان 25,000
 حساب داریانان / حساب داریانان 3 حساب داریانان سود، طبقاً به ماده 5 از قانون ثبت اسناد و املاک (اصولاً در حساب داریانان)
 حساب داریانان (اصولاً در حساب داریانان) حساب داریانان در حساب داریانان 100,000 حساب داریانان حساب داریانان حساب داریانان حساب داریانان

از طرف حساب داریانان / حساب داریانان حساب داریانان حساب داریانان حساب داریانان حساب داریانان حساب داریانان حساب داریانان
 حساب داریانان حساب داریانان حساب داریانان حساب داریانان حساب داریانان حساب داریانان حساب داریانان (5-)

*** نکته-2:** حساب داریانان حساب داریانان حساب داریانان حساب داریانان حساب داریانان حساب داریانان حساب داریانان
 حساب داریانان حساب داریانان حساب داریانان حساب داریانان حساب داریانان حساب داریانان حساب داریانان

مرفق 2 - نموذج ضمان البنك / ضمان الأداء - مرفق 2

Form of Tender Security (Bank Guarantee)

The Issuing Bank shall fill in this Bank Guarantee Form in accordance with the instructions indicated.

..... {Bank's Name, and Address of Issuing Branch or Office}

Beneficiary: {Name and Address of Employer}

Date:

TENDER GUARANTEE No.: _____

We have been informed that _____ {name of the Tenderer} (hereinafter called "the Tenderer") has submitted to you its Tender dated _____ (hereinafter called "the Tender") for the execution of _____ {name of contract} under Invitation for Tenders No. _____ ("the IFB").

Furthermore, we understand that, according to your conditions, Tenders must be supported by a Tender guarantee.

At the request of the Tenderer, we _____ {name of Bank} hereby irrevocably undertake to pay you any sum or sums not exceeding in total an amount of _____ [amount in figures] (_____) [amount in words] upon receipt by us of your first demand in writing accompanied by a written statement stating that the Tenderer is in breach of its obligation(s) under the Tender conditions, because the Tenderer:

- (a) has withdrawn its Tender during the period of Tender validity specified by the Tenderer in the Form of Tender; or
- (b) having been notified of the acceptance of its Tender by the Employer during the period of Tender validity, (i) fails or refuses to execute the Contract Form, if required, or (ii) fails or refuses to furnish the performance security, in accordance with the ITB.

This guarantee will expire: (a) if the Tenderer is the successful Tenderer, upon our receipt of copies of the contract signed by the Tenderer and the performance security issued to you upon the instruction of the Tenderer; and (b) if the Tenderer is not the successful Tenderer, upon the earlier of (i) our receipt of a copy your notification to the Tenderer of the name of the successful Tenderer; or (ii) {insert date} twenty-eight days after the expiration of the Tenderer's Tender.

Consequently, any demand for payment under this guarantee must be received by us at the office on or before that date.

This guarantee is subject to the Uniform Rules for Demand Guarantees, ICC Publication No. 458

[Signature(s)]

مادة 3 - ضمان الأداء

Performance Security

[The issuing bank, as requested by the successful Contractor, shall fill in this form in accordance with the instructions indicated]

Date: [insert date (as day, month, and year)]

Title of the procurement: [Insert general title of the procurement]

Procurement Reference No: [insert reference]

Bank's Branch or Office: [insert complete name of Guarantor]

Beneficiary: [insert complete name of Employer/Procuring Entity]

Performance Guarantee No:

We have been informed that [name of the Contractor], (hereinafter called "the Contractor") has entered into Contract No. [procurement reference number of the Contract], dated [insert day and month], [insert year], with you, for the execution of [name of contract and brief description of Works] (hereinafter called "the Contract").

Furthermore, we understand that, according to the conditions of the Contract, a performance guarantee is required.

At the request of the Contractor, we [name of the Bank] hereby irrevocably undertake to pay you any sum or sums not exceeding in total an amount of [name of the currency and amount in figures] ¹.... (. . . . [amount in words]) such sum being payable in the types and proportions of currencies in which the Contract Price is payable, upon receipt by us of your first demand in writing accompanied by a written statement stating that the Contractor is in breach of its obligation(s) under the Contract, without your needing to prove or to show grounds for your demand or the sum specified therein.

This guarantee shall expire, no later than the day of , ², and any demand for payment under it must be received by us at this office on or before that date. The Guarantor agrees to a one-time extension of this guarantee for a period not to exceed[six months][one year], in response to the Employer's written request for such extension, such request to be presented to the Guarantor before the expiry of the guarantee.

This guarantee is subject to the Uniform Rules for Demand Guarantees, ICC Publication No. 458, except that subparagraph (ii) of Sub-article 20(a) is hereby excluded.

.....
[Seal of Bank and Signature(s)]

Note –

All italicized text is for guidance on how to prepare this demand guarantee and shall be deleted from the final document.

¹ The Guarantor shall insert an amount representing the percentage of the Contract Price specified in the Contract and denominated either in the currency (ies) of the Contract or a freely convertible currency acceptable to the Employer.

² Insert the date twenty-eight days after the expected completion date. The Employer should note that in the event of an extension of the time for completion of the Contract, the Employer would need to request an extension of this guarantee from the Guarantor. Such request must be in writing and must be made prior to the expiration date established in the guarantee.

بِسْمِ اللَّهِ الرَّحْمَنِ الرَّحِيمِ - 4 -

Advance Payment Security

[The bank, as requested by the successful Contractor, shall fill in this form in accordance with the instructions indicated.]

Date: [insert date (as day, month, and year)]

Title of the Procurement: [Insert general title of the procurement]

Procurement Reference No: [insert reference]

[Issuing bank's letterhead]

Beneficiary: [insert legal name and address of Procuring Entity]

ADVANCE PAYMENT GUARANTEE No.: [insert Advance Payment Guarantee no.]

Advance Payment Guarantee No:

We have been informed that [name of the Contractor] (hereinafter called "the Contractor") has entered into Contract No..... [procurement reference number of the Contract], dated [insert day and month], [insert year] with you, for the execution of [name of contract and brief description of Works] (hereinafter called "the Contract").

Furthermore, we understand that, according to the Conditions of the Contract, an advance payment in the sum [name of the currency and amount in figures] ¹ (..... [amount in words]) is to be made against an advance payment guarantee.

At the request of the Contractor, we [name of the Bank]. hereby irrevocably undertake to pay you any sum or sums not exceeding in total an amount of [name of the currency and amount in figures]* (..... [amount in words]) upon receipt by us of your first demand in writing accompanied by a written statement stating that the Contractor is in breach of its obligation under the Contract because the Contractor used the advance payment for purposes other than the costs of mobilization in respect of the Works.

It is a condition for any claim and payment under this guarantee to be made that the advance payment referred to above must have been received by the Contractor on its account number[Contractor's account number]. at [name and address of the Contractor's Bank].

The maximum amount of this guarantee shall be progressively reduced by the amount of the advance payment repaid by the Contractor as indicated in copies of interim statements or payment certificates which shall be presented to us. This guarantee shall expire, at the latest, upon our receipt of a copy of the interim payment certificate indicating that eighty (80) percent of the Contract Price has been certified for payment, or on the day of², whichever is earlier. Consequently, any demand for payment under this guarantee must be received by us at this office on or before that date. The Guarantor agrees to a one-time extension of this guarantee for a period not to exceed [six months][one year], in response to the Employer's written request for such extension, such request to be presented to the Guarantor before the expiry of the guarantee.

This guarantee is subject to the Uniform Rules for Demand Guarantees, ICC Publication No. 458.

..... [Seal of Bank and Signature(s)].

Note

All italicized text is for guidance in preparing this demand guarantee and shall be deleted from the final document.

1 The Guarantor shall insert an amount representing the amount of the advance payment denominated either in the currency(ies) of the advance payment as specified in the Contract, or in a freely convertible currency acceptable to the Employer.

2 Insert the expected expiration date of the Time for Completion. The Employer should note that in the event of an extension of the time for completion of the Contract, the Employer would need to request an extension of this guarantee from the Guarantor. Such request must be in writing and must be made prior to the expiration date established in the guarantee

تجربہ کاروں کی فہرست (2 - حصہ) - 5 - 2024/38

Annex:5					
Company Name:					
Experience Form: Announcement- 57-T/IU/2024/38					
Scope:	Building Maintenance works				
#	Project Name	Client Name	Project cost	Reference Letter Date	For Official Use Only
1					
2					
3					
4					
5					
6					
7					
....					
Note: Copy of reference letters should be attached					

جَعَلَهُ اللَّهُ سَعَادَةً لِعِبَادِهِ - وَبَارَكْ وَسَلَّمْ (سورة المائدة - 3) اَللّٰهُمَّ

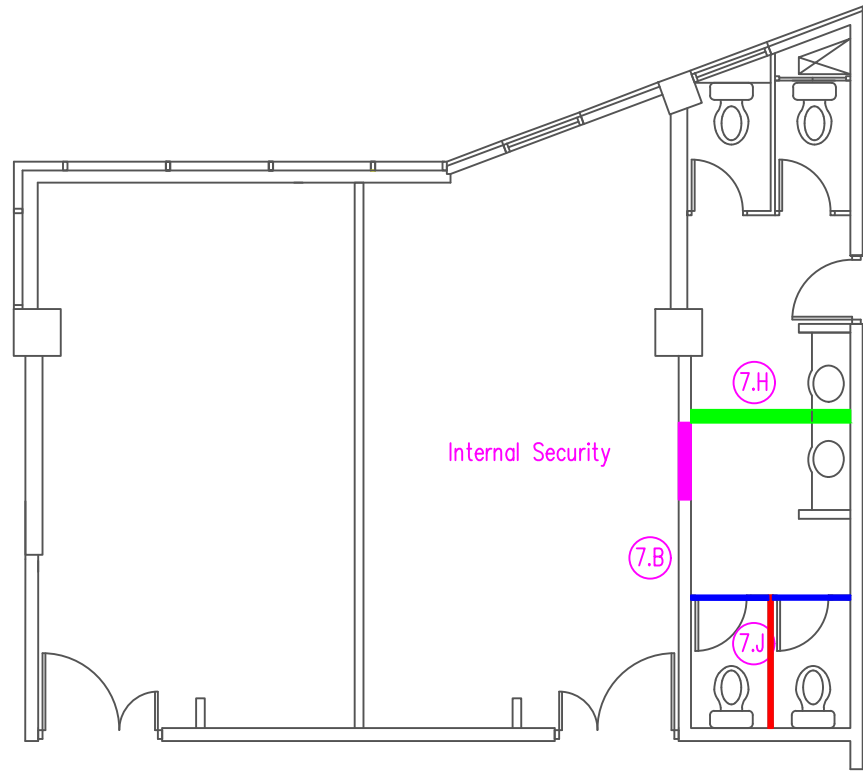

LEGEND

- ①.1 900MM X 2150MM WALL TO BE DEMOLISHED (FOR DOOR ENTRANCE)
- ①.2 WALL TO BE DEMOLISHED
- ①.3 WALL TO BE DEMOLISHED
- ①.4 1860 X 3120MM SOLID BLOCK WALL TO BUILD

WALL LEGEND

⑦.A	100MM THICK EXTERNAL SOLID BLOCK WALL WITH ALUMINIUM CLADDING FINISH
⑦.B	150MM THICK SOLID MASONRY BLOCKS FULL WALL ON CEMENT PLASTER AND PAINTED FINISH
⑦.C	100MM THICK INTERNAL SOLID BLOCK FULL WALL ON CEMENT PLASTER AND PAINTED FINISH
⑦.D	100MM THICK X 2100MM HIGH MASONRY WALL ON CEMENT PLASTER AND PAINTED FINISH
⑦.E	RCC WALL WITH MARBLE FINISH
⑦.F	RCC WALL WITH CEMENT PLASTER AND PAINTED FINISH
⑦.G	100MM THICK MASONRY WALL WITH MARBLE FINISH
⑦.H	150MM THICK SOLID MASONRY BLOCKS FULL WALL ON 600X300 CERAMIC WALL TILE
⑦.I	90MM THICK WOODEN PARTITION
⑦.J	100MM THICK INTERNAL SOLID BLOCK FULL WALL ON 600X300 CERAMIC WALL TILE

NOTES :
 ALL MEASUREMENTS TO BE CHECKED ON SITE BEFORE
 IMPLEMENTATION

PROJECT : DEMOLITION & MASONRYS WORKS
7TH FLOOR
INTERNAL SECURITY/ EAST GENTS TOILETS

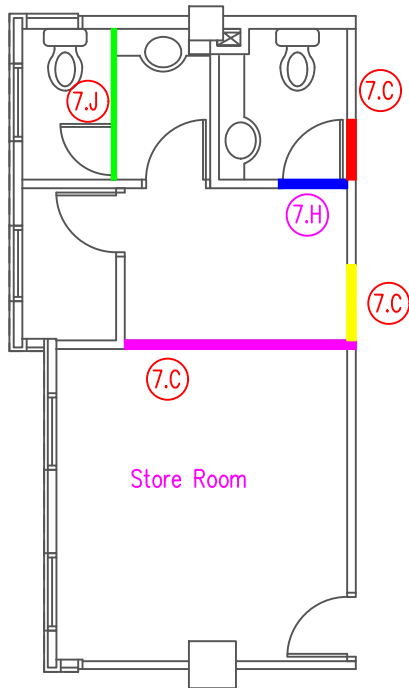

LEGEND

- ①.5 2600MM X 2775MM WALL TO BE DEMOLISHED
- ①.6 700MM X 2150MM SOLID BLOCK WALL TO BUILD
- ①.7 700MM X 2150MM WALL TO BE DEMOLISHED (FOR DOOR ENTRANCE)
- ①.8 1700MM X 3120MM WALL TO BE DEMOLISHED
- ①.9 900MM X 3120MM SOLID BLOCK WALL TO BUILD WITH BOTH CEMENT PLASTER

WALL LEGEND

⑦.A	100MM THICK EXTERNAL SOLID BLOCK WALL WITH ALUMINIUM CLADDING FINISH
⑦.B	150MM THICK SOLID MASONRY BLOCKS FULL WALL ON CEMENT PLASTER AND PAINTED FINISH
⑦.C	100MM THICK INTERNAL SOLID BLOCK FULL WALL ON CEMENT PLASTER AND PAINTED FINISH
⑦.D	100MM THICK X 2100MM HIGH MASONRY WALL ON CEMENT PLASTER AND PAINTED FINISH
⑦.E	RCC WALL WITH MARBLE FINISH
⑦.F	RCC WALL WITH CEMENT PLASTER AND PAINTED FINISH
⑦.G	100MM THICK MASONRY WALL WITH MARBLE FINISH
⑦.H	150MM THICK SOLID MASONRY BLOCKS FULL WALL ON 600X300 CERAMIC WALL TILE
⑦.I	90MM THICK WOODEN PARTITION
⑦.J	100MM THICK INTERNAL SOLID BLOCK FULL WALL ON 600X300 CERAMIC WALL TILE

NOTES :
ALL MEASUREMENTS TO BE CHECKED ON SITE BEFORE IMPLEMENTATION

PROJECT : DEMOLITION & MASONRY'S WORKS
7TH FLOOR
STORE ROOM/ TOILETS

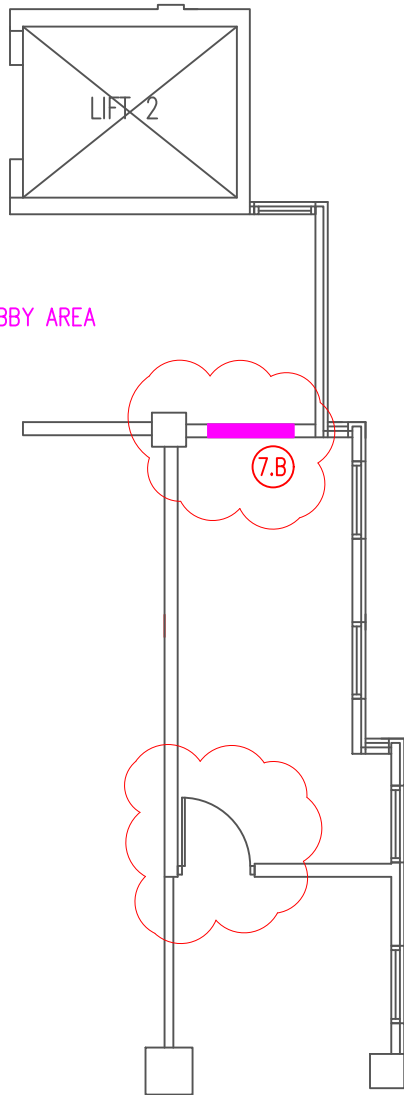

LEGEND

- 2.1 100MM X 2200MM WALL TO BE DEMOLISHED (FOR DOOR ENTRANCE)

WALL LEGEND

7.A	100MM THICK EXTERNAL SOLID BLOCK WALL WITH ALUMINIUM CLADDING FINISH
7.B	150MM THICK SOLID MASONRY BLOCKS FULL WALL ON CEMENT PLASTER AND PAINTED FINISH
7.C	100MM THICK INTERNAL SOLID BLOCK FULL WALL ON CEMENT PLASTER AND PAINTED FINISH
7.D	100MM THICK X 2100MM HIGH MASONRY WALL ON CEMENT PLASTER AND PAINTED FINISH
7.E	RCC WALL WITH MARBLE FINISH
7.F	RCC WALL WITH CEMENT PLASTER AND PAINTED FINISH
7.G	100MM THICK MASONRY WALL WITH MARBLE FINISH
7.H	150MM THICK SOLID MASONRY BLOCKS FULL WALL ON 600X300 CERAMIC WALL TILE
7.I	90MM THICK WOODEN PARTITION
7.J	100MM THICK INTERNAL SOLID BLOCK FULL WALL ON 600X300 CERAMIC WALL TILE

NOTES :
ALL MEASUREMENTS TO BE CHECKED ON SITE BEFORE IMPLEMENTATION

PROJECT : DEMOLITION & MASONRY'S WORKS
4TH FLOOR
LOBBY AREA

