

**Ministry of Higher  
Education  
Male', Republic of Maldives**

**BIDDING DOCUMENT**

**FOR THE**

**Supply, delivery and installation of  
Laboratory Equipment at Maldives  
Polytechnic.**

**(IUL) 475/475/2019/200**

**17<sup>th</sup> December 2019**

**STANDARD**

**BIDDING DOCUMENT**

**For the Procurement of:** Supply, delivery and installation of  
Laboratory Equipment at Maldives  
Polytechnic.

**Procuring Entity:** Maldives: Enhancing Employability and  
Resilience of youth project.  
Ministry of Higher Education, Male'  
Maldives

**Date of Issue:** 17<sup>th</sup> December 2019

## **Table of Contents**

	<i>Page Number</i>
PART 1.....	4
Bidding Procedures .....	4
Section I. Instructions to Bidders.....	5
Section II. Bid Data Sheet (BDS ).....	22
Section III. Evaluation and Qualification Criteria.....	26
Section IV. Bidding Forms .....	31
Section V. Eligible Countries .....	42
PART 2 – Supply Requirements .....	43
Section VI. Schedule of Requirements .....	44
PART 3 - Contract.....	69
Section VII. General Conditions of Contract .....	70
Section VIII. Special Conditions of Contract.....	84
Section IX. Contract Forms .....	89

## **PART 1**

### **Bidding Procedures**

## **Section I. Instructions to Bidders**

### **Table of Contents**

A. General .....	7
1. Scope of Bid .....	7
2. Source of Funds .....	7
3. Fraud and Corruption.....	7
4. Eligible Bidders .....	8
5. Eligible Goods and Related Services.....	9
B. Contents of Bidding Documents .....	9
6. Sections of Bidding Documents .....	9
7. Clarification of Bidding Documents.....	10
8. Amendment of Bidding Documents .....	10
C. Preparation of Bids .....	10
9. Cost of Bidding.....	10
10. Language of Bid .....	10
11. Documents Comprising the Bid.....	11
12. Bid Submission Form and Price Schedules .....	11
13. Alternative Bids .....	11
14. Bid Prices and Discounts .....	11
15. Currencies of Bid.....	12
16. Documents Establishing the Eligibility of the Bidder .....	12
17. Documents Establishing the Eligibility of the Goods and Related Services ..	13
18. Documents Establishing the Conformity of the Goods and Related Services	13
19. Documents Establishing the Qualifications of the Bidder.....	13
20. Period of Validity of Bids.....	13
21. Bid Security .....	14
22. Format and Signing of Bid .....	15
D. Submission and Opening of Bids .....	15
23. Submission, Sealing and Marking of Bids .....	15
24. Deadline for Submission of Bids .....	15
25. Late Bids .....	16
26. Withdrawal, Substitution, and Modification of Bids.....	16
27. Bid Opening.....	16

**BIDDING DOCUMENT FOR THE PROCUREMENT OF POLYTECHNIC  
LABORATORY ITEM**

---

---

E. Evaluation and Comparison of Bids.....	17
28. Confidentiality .....	17
29. Clarification of Bids .....	17
30. Responsiveness of Bids .....	17
31. Nonconformities, Errors, and Omissions.....	18
32. Preliminary Examination of Bids .....	18
33. Examination of Terms and Conditions; Technical Evaluation.....	18
34. Conversion to Single Currency.....	19
35. Domestic Preference .....	19
36. Evaluation of Bids .....	19
37. Comparison of Bids .....	19
38. Post qualification of the Bidder .....	19
39. Procuring Entity’s Right to Accept Any Bid, and to Reject Any or All Bids	20
F. Award of Contract .....	20
40. Award Criteria .....	20
41. Procuring Entity’s Right to Vary Quantities at Time of Award.....	20
42. Notification of Award.....	20
43. Signing of Contract.....	21
44. Performance Security.....	21

## **Section I. Instructions to Bidders**

### **A. General**

#### **1. Scope of Bid**

- 1.1 The Procuring Entity **indicated in the Bid Data Sheet (BDS)**, issues these Bidding Documents for the supply of Goods and Related Services incidental thereto as specified in Section VI, Schedule of Requirements. The name and procurement reference number of this Bid Invitation are **specified in the BDS**. The name, identification, and number of lots are also **provided in the BDS**.
- 1.2 Throughout this Bidding Document:
- (a) the term “in writing” means communicated in written form (e.g. by mail, e-mail, fax, telex) with proof of receipt;
  - (b) if the context so requires, “singular” means “plural” and vice versa; and
  - (c) “day” means calendar day.

#### **2. Source of Funds**

- 2.1 The Procuring Entity has an approved budget from the Government of the Maldives which has been allocated towards the acquisition of the goods for which this bid has been issued. The Procuring Entity intends to apply the allocated funds to eligible payments under a contract for the supply and delivery of these goods as detailed in this Bidding Document.
- 2.2 Payments will be made only at the request of the Procuring Entity in accordance with contact terms and conditions and in accordance with financial legislation in force.

#### **3. Fraud and Corruption**

- 3.1 It is the Government’s policy to require that Procuring Entities, as well as Bidders, suppliers, and contractors and their subcontractors, observe the highest standard of ethics during the procurement and execution of such contracts. In pursuance of this policy, the Government:
- (a) defines, for the purposes of this provision, the terms set forth below as follows:
    - (i) “corrupt practice” is the offering, giving, receiving or soliciting, directly or indirectly, of anything of value to influence improperly the actions of another party;
    - (ii) “fraudulent practice” is any act or omission, including a misrepresentation, that knowingly or recklessly misleads, or attempts to mislead, a party to obtain a financial or other benefit or to avoid an obligation;
    - (iii) “collusive practice” is an arrangement between two or more parties designed to achieve an improper purpose, including to influence improperly the actions of another party;
    - (iv) “coercive practice” is impairing or harming, or threatening to impair or harm, directly or indirectly, any party or the property of the party to influence improperly the actions of a party;
    - (v) “obstructive practice” is
      - (a) deliberately destroying, falsifying, altering or concealing of evidence material to the investigation or making false statements to investigators in order to materially impede a Government investigation into allegations of a corrupt,

## **BIDDING DOCUMENT FOR THE PROCUREMENT OF POLYTECHNIC LABORATORY ITEM**

---

fraudulent, coercive or collusive practice; and/or threatening, harassing or intimidating any party to prevent it from disclosing its knowledge of matters relevant to the investigation or from pursuing the investigation; or

- (b) acts intended to materially impede the exercise of the Government's inspection and audit rights provided for under sub-clause 3.1 (e) below.
  - (b) will reject a proposal for award if it determines that the Bidder recommended for award has, directly or through an agent, engaged in corrupt, fraudulent, collusive, coercive or obstructive practices in competing for the contract in question;
  - (c) will cancel in whole or in part the portion of the contract if it determines at any time that representatives of the Procuring Entity engaged in corrupt, fraudulent, collusive, or coercive practices during the procurement or the execution of that contract, without the Government having taken timely and appropriate action satisfactory to address such practices when they occur;
  - (d) will suspend a firm or individual from participation in public procurement, by declaring it ineligible, either indefinitely or for a stated period of time, to be awarded a Government funded contract if it at any time determines that the firm has, directly or through an agent, engaged in corrupt, fraudulent, collusive, coercive or obstructive practices in competing for, or in executing, a Government funded contract; and
  - (e) will have the right to require that a provision be included in bidding documents and in contracts financed by the Government, requiring Bidders, suppliers, and contractors and their sub-contractors to permit the Government to inspect their accounts and records and other documents relating to the bid submission and contract performance and to have them audited by auditors appointed by the Government.
- 3.2 Furthermore, Bidders shall be aware of the provision stated in Sub-Clause 34.1 (a) (iii) of the General Conditions of Contract.

### **4. Eligible Bidders**

- 4.1 A Bidder, and all parties constituting the Bidder, may have the nationality of any country, subject to the restrictions specified in Section V, Eligible Countries. A Bidder shall be deemed to have the nationality of a country if the Bidder is a citizen or is constituted, incorporated, or registered and operates in conformity with the provisions of the laws of that country. This criterion shall also apply to the determination of the nationality of proposed subcontractors or suppliers for any part of the Contract including Related Services.
- 4.2 A Bidder shall meet the following criteria to be eligible to participate in public procurement:
- (a) have the legal capacity to enter into the contract;
  - (b) not be insolvent, in receivership, bankrupt or being wound up, its affairs not being administered by a court or a judicial officer, its business activities not being suspended and not the subject of legal proceedings for any of the foregoing;
  - (c) have fulfilled its obligations to pay taxes and social security contributions;
  - (d) not have been, and its directors or officers not have been, convicted of any criminal offence related to their professional conduct or the making of false statements or misrepresentations as to their qualifications to enter into a contract within a period of five years preceding the commencement of the procurement proceedings; and
  - (e) not have a conflict of interest in relation to the procurement requirement in accordance with Sub-Clause 4.3.
- 4.3 All Bidders found to have conflict of interest shall be disqualified. Bidders may be considered to



# **BIDDING DOCUMENT FOR THE PROCUREMENT OF POLYTECHNIC LABORATORY ITEM**

---

have a conflict of interest with one or more parties in this bidding process, if they:

- (a) are or have been associated in the past, with a firm or any of its affiliates which have been engaged by the Procuring Entity to provide consulting services for the preparation of the design, specifications, and other documents to be used for the procurement of the goods to be purchased under these Bidding Documents ; or
  - (b) submit more than one bid in this bidding process, except for alternative offers permitted under ITT Clause 13. However, this does not limit the participation of subcontractors in more than one bid;
- 4.4 A Bidder that has been suspended from participation in public procurement by the Government in accordance with ITT Clause 3, at the date of contract award, shall not be eligible to be awarded a contract. The list of suspended firms is available at the electronic address specified in the **BDS**.
- 4.5 Government-owned Enterprise in the Republic of Maldives shall be eligible only if they can establish that they (i) are legally and financially autonomous, (ii) operate under commercial law, and (iii) are not a dependent agency of the Procuring Entity.
- 4.6 Bidders shall provide such evidence of their continued eligibility satisfactory to the Procuring Entity, as the Procuring Entity shall reasonably request.

## **5. Eligible Goods and Related Services**

- 5.1 All the Goods and Related Services to be supplied under the Contract must have their origin in an eligible country, in accordance with Section V, Eligible Countries.
- 5.2 For purposes of this Clause, the term “goods” includes commodities, raw material, machinery, equipment, and industrial plants; and “related services” includes services such as insurance, installation, training, and initial maintenance.
- 5.3 The term “origin” means the country where the goods have been mined, grown, cultivated, produced, manufactured or processed; or, through manufacture, processing, or assembly, another commercially recognized article results that differs substantially in its basic characteristics from its components.

## **B. Contents of Bidding Documents**

### **6. Sections of Bidding Documents**

- 6.1 The Bidding Documents consist of Parts 1, 2, and 3, which include all the Sections indicated below, and should be read in conjunction with any Addendum issued in accordance with ITT Clause 8.

#### **PART 1 Bidding Procedures**

- Section I. Instructions to Bidders (ITT)
- Section II. Bid Data Sheet (BDS)
- Section III. Evaluation and Qualification Criteria
- Section IV. Bidding Forms
- Section V. Eligible Countries

# BIDDING DOCUMENT FOR THE PROCUREMENT OF POLYTECHNIC LABORATORY ITEM

---

## **PART 2 Supply Requirements**

- Section VI. Schedule of Requirements

## **PART 3 Contract**

- Section VII. General Conditions of Contract (GCC)
- Section VIII. Special Conditions of Contract (SCC)
- Section IX. Contract Forms

- 6.2 The Invitation for Bids issued by the Procuring Entity is not part of the Bidding Documents.
- 6.3 The Procuring Entity is not responsible for the completeness of the Bidding Documents and their addendum, if these documents were not obtained directly from the Procuring Entity.
- 6.4 The Bidder is expected to examine all instructions, forms, terms, and specifications in the Bidding Documents. Failure to furnish all information or documentation required by the Bidding Documents may result in the rejection of the bid.

## **7. Clarification of Bidding Documents**

- 7.1 A prospective Bidder requiring any clarification of the Bidding Documents shall contact the Procuring Entity in writing at the Procuring Entity's address **specified in the BDS**. The Procuring Entity will respond in writing to any request for clarification, provided that such request is received no later than twenty-one (21) days prior to the deadline for submission of bids. The Procuring Entity shall forward copies of its response to all those who have acquired the Bidding Documents directly from it, including a description of the inquiry but without identifying its source. Should the Procuring Entity deem it necessary to amend the Bidding Documents as a result of a clarification, it shall do so following the procedure under ITT Clause 8 and ITT Sub-Clause 24.2.

## **8. Amendment of Bidding Documents**

- 8.1 At any time prior to the deadline for submission of bids, the Procuring Entity may amend the Bidding Documents by issuing addendum.
- 8.2 Any addendum issued shall be part of the Bidding Documents and shall be communicated in writing to all who have obtained the Bidding Documents directly from the Procuring Entity.
- 8.3 To give prospective Bidders reasonable time in which to take an addendum into account in preparing their bids, the Procuring Entity may, at its discretion, extend the deadline for the submission of bids, pursuant to ITT Sub-Clause 24.2

## **C. Preparation of Bids**

### **9. Cost of Bidding**

- 9.1 The Bidder shall bear all costs associated with the preparation and submission of its bid, and the Procuring Entity shall not be responsible or liable for those costs, regardless of the conduct or outcome of the bidding process.

### **10. Language of Bid**

- 10.1 The Bid, as well as all correspondence and documents relating to the bid exchanged by the Bidder and the Procuring Entity, shall be written in the language **specified in the BDS**. Supporting documents and printed literature that are part of the Bid may be in another language provided they are accompanied by an accurate translation of the relevant passages into the language **specified in the BDS**, in which case, for purposes of interpretation of the Bid, such

# BIDDING DOCUMENT FOR THE PROCUREMENT OF POLYTECHNIC LABORATORY ITEM

---

translation shall govern.

## 11. Documents Comprising the Bid

11.1 The Bid shall comprise the following:

- (a) Bid Submission Form and the applicable Price Schedules, in accordance with ITT Clauses 12, 14, and 15;
- (b) Bid Security or Bid-Securing Declaration, in accordance with ITT Clause 21, if required;
- (c) written confirmation authorizing the signatory of the Bid to commit the Bidder, in accordance with ITT Clause 22;
- (d) documentary evidence in accordance with ITT Clause 16 establishing the Bidder's eligibility to bid;
- (e) documentary evidence in accordance with ITT Clause 17, that the Goods and Related Services to be supplied by the Bidder are of eligible origin;
- (f) documentary evidence in accordance with ITT Clauses 18 and 30, that the Goods and Related Services conform to the Bidding Documents;
- (g) documentary evidence in accordance with ITT Clause 19 establishing the Bidder's qualifications to perform the contract if its bid is accepted; and
- (h) any other document **required in the BDS**.

## 12. Bid Submission Form and Price Schedules

12.1 The Bidder shall submit the Bid Submission Form using the form furnished in Section IV, Bidding Forms. This form must be completed without any alterations to its format, and no substitutes shall be accepted. All blank spaces shall be filled in with the information requested.

12.2 The Bidder shall submit the Price Schedules for Goods and Related Services, according to their origin as appropriate, using the forms furnished in Section IV, Bidding Forms

## 13. Alternative Bids

13.1 Unless otherwise **specified in the BDS**, alternative bids shall not be considered.

## 14. Bid Prices and Discounts

14.1 The prices and discounts quoted by the Bidder in the Bid Submission Form and in the Price Schedules shall conform to the requirements specified below.

14.2 All lots and items must be listed and priced separately in the Price Schedules.

14.3 The price to be quoted in the Bid Submission Form shall be the total price of the bid, including any discounts offered.

14.4 The Bidder shall quote any unconditional discounts and indicate the method for their application in the Bid Submission Form.

14.5 The terms EXW, CIP, and other similar terms shall be governed by the rules prescribed in the current edition of Incoterms, published by The International Chamber of Commerce, as specified in the **BDS**.

14.6 Prices shall be quoted as specified in the Price Schedule included in Section IV, Bidding Forms. In quoting prices, the Bidder shall be free to use transportation through carriers registered in any eligible country, in accordance with Section V Eligible Countries. Similarly, the Bidder may obtain insurance services from any eligible country in accordance with Section V Eligible

# BIDDING DOCUMENT FOR THE PROCUREMENT OF POLYTECHNIC LABORATORY ITEM

---

Countries. Prices shall include the following costs and components:

- (a) For Goods
  - (i) the price of the Goods, delivered to the final destination as required in the BDS quoted either:
    - a. DDP named place of final destination (Maldives Polytechnic, Male Campus), in the Republic of Maldives
    - b. EXW (ex works, ex-factory, ex warehouse, ex showroom or off the shelf) including all customs duties and sales and other taxes already paid or payable;
  - (ii) the price for inland transportation, insurance, and other local services required to convey the Goods from the named place or port of destination to their final destination **specified in the BDS**;
  - (iii) the custom duties and other import taxes to be paid on the Goods on entry in the Republic of Maldives if not already included in 14(a)(i)b;
  - (iv) any sales and other taxes due within the Republic of Maldives which will be payable on the Goods if not already included in 14(a)(i)b;
  - (v) any rebate or mark-up of the local agent or representative.
- (b) for Related Services, other than inland transportation and other services required to convey the Goods to their final destination, whenever such Related Services are specified in the Schedule of Requirements:
  - (i) the price of each item comprising the Related Services (inclusive of any applicable taxes).

14.7 Prices quoted by the Bidder shall be fixed during the Bidder's performance of the Contract and not subject to variation on any account, unless otherwise specified in the **BDS**. A Bid submitted with an adjustable price quotation shall be treated as non-responsive and shall be rejected, pursuant to ITT Clause 30. However, if in accordance with the **BDS**, prices quoted by the Bidder shall be subject to adjustment during the performance of the Contract, a bid submitted with a fixed price quotation shall not be rejected, but the price adjustment shall be treated as zero.

14.8 If so indicated in ITT Sub-Clause 1.1, bids are being invited for individual contracts (lots) or for any combination of contracts (packages). Unless otherwise indicated in the **BDS**, prices quoted shall correspond to 100% of the items specified for each lot and to 100% of the quantities specified for each item of a lot. Bidders wishing to offer any price reduction (discount) for the award of more than one Contract shall specify the applicable price reduction in accordance with ITT Sub-Clause 14.4 provided the bids for all lots are submitted and opened at the same time.

## 15. Currencies of Bid

15.1 Unless otherwise specified in the **BDS**, the Bidder shall quote entirely in Maldivian Rufiyaa.

Where the BDS permits bids in other currencies, the Bidder may express the bid price in the currency of any country in accordance with Section V, Eligible countries but shall use no more than one currency.

## 16. Documents Establishing the Eligibility of the Bidder

16.1 To establish their eligibility in accordance with ITT Clause 4, Bidders shall complete the Bid Submission Form, included in Section IV, Bidding Forms.

# BIDDING DOCUMENT FOR THE PROCUREMENT OF POLYTECHNIC LABORATORY ITEM

---

## 17. Documents Establishing the Eligibility of the Goods and Related Services

- 17.1 To establish the eligibility of the Goods and Related Services in accordance with ITT Clause 5, Bidders shall complete the country of origin declarations in the Price Schedule Forms, included in Section IV, Bidding Forms.

## 18. Documents Establishing the Conformity of the Goods and Related Services

- 18.1 To establish the conformity of the Goods and Related Services to the Bidding Documents, the Bidder shall furnish as part of its Bid the documentary evidence that the Goods conform to the technical specifications and standards specified in Section VI, Schedule of Requirements.
- 18.2 The documentary evidence may be in the form of literature, drawings or data, and shall consist of a detailed item by item description of the essential technical and performance characteristics of the Goods and Related Services, demonstrating substantial responsiveness of the Goods and Related Services to the technical specification, and if applicable, a statement of deviations and exceptions to the provisions of the Schedule of Requirements.
- 18.3 The Bidder shall also furnish a list giving full particulars, including available sources and current prices of spare parts, special tools, etc., necessary for the proper and continuing functioning of the Goods during the period **specified in the BDS** following commencement of the use of the goods by the Procuring Entity.
- 18.4 Standards for workmanship, process, material, and equipment, as well as references to brand names or catalogue numbers specified by the Procuring Entity in the Schedule of Requirements, are intended to be descriptive only and not restrictive. The Bidder may offer other standards of quality, brand names, and/or catalogue numbers, provided that it demonstrates, to the Procuring Entity's satisfaction, that the substitutions ensure substantial equivalence or are superior to those specified in the Schedule of Requirements.

## 19. Documents Establishing the Qualifications of the Bidder

- 19.1 The documentary evidence of the Bidder's qualifications to perform the contract if its bid is accepted shall establish to the Procuring Entity's satisfaction that:
- (a) if required in the BDS, a Bidder that does not manufacture or produce the Goods it offers to supply shall submit the Manufacturer's Authorization using the form included in Section IV, Bidding Forms to demonstrate that it has been duly authorized by the manufacturer or producer of the Goods to supply these Goods in the Republic of Maldives;
  - (b) if required in the BDS, in case of a Bidder not doing business within the Republic of Maldives, the Bidder is or will be (if awarded the contract) represented by an Agent in the Maldives equipped and able to carry out the Supplier's maintenance, repair and spare parts-stocking obligations prescribed in the Conditions of Contract and/or Technical Specifications; and
  - (c) the Bidder meets each of the qualification criterion specified in Section III, Evaluation and Qualification Criteria.

## 20. Period of Validity of Bids

- 20.1 Bids shall remain valid for the period **specified in the BDS** after the bid submission deadline date prescribed by the Procuring Entity. A bid valid for a shorter period shall be rejected by the Procuring Entity as non responsive.
- 20.2 In exceptional circumstances, prior to the expiration of the bid validity period, the Procuring Entity may request Bidders to extend the period of validity of their bids. The request and the

## **BIDDING DOCUMENT FOR THE PROCUREMENT OF POLYTECHNIC LABORATORY ITEM**

---

responses shall be made in writing. If a Bid Security is requested in accordance with ITT Clause 21, it shall also be extended for a corresponding period. A Bidder may refuse the request without forfeiting its Bid Security. A Bidder granting the request shall not be required or permitted to modify its bid, except as provided in ITT Sub-Clause 20.3.

- 20.3 In the case of fixed price contracts, if the award is delayed by a period exceeding fifty-six (56) days beyond the expiry of the initial bid validity, the Contract price shall be adjusted as specified in the request for extension. Bid evaluation shall be based on the Bid Price without taking into consideration the above correction.

### **21. Bid Security**

- 21.1 The Bidder shall furnish as part of its bid, a Bid Security or a Bid-Securing Declaration, if required, as **specified in the BDS**.
- 21.2 The Bid Security shall be in the amount specified in the BDS and denominated in Maldivian Rufiyaa or a freely convertible currency, and shall:
- (a) at the Bidder's option, be in the form of either a letter of credit, or a bank guarantee from a banking institution, or a bond issued by a surety;
  - (b) be issued by a reputable institution selected by the Bidder and located in any eligible country. If the institution issuing the bond is located outside the Republic of Maldives, it shall have a correspondent financial institution located in the Republic of Maldives to make it enforceable.
  - (c) be substantially in accordance with one of the forms of Bid Security included in Section IV, Bidding Forms, or other form approved by the Procuring Entity prior to bid submission;
  - (d) be payable promptly upon written demand by the Procuring Entity in case the conditions listed in ITT Clause 21.5 are invoked;
  - (e) be submitted in its original form; copies will not be accepted;
  - (f) remain valid for a period of 28 days beyond the validity period of the bids, as extended, if applicable, in accordance with ITT Clause 20.2;
- 21.3 If a Bid Security or a Bid- Securing Declaration is required in accordance with ITT Sub-Clause 21.1, any bid not accompanied by a substantially responsive Bid Security or Bid Securing Declaration in accordance with ITT Sub-Clause 21.1, shall be rejected by the Procuring Entity as non-responsive.
- 21.4 The Bid Security of unsuccessful Bidders shall be returned as promptly as possible upon the successful Bidder's furnishing of the Performance Security pursuant to ITT Clause 44.
- 21.5 The Bid Security may be forfeited or the Bid Securing Declaration executed:
- (a) if a Bidder withdraws its bid during the period of bid validity specified by the Bidder on the Bid Submission Form, except as provided in ITT Sub-Clause 20.2; or
  - (b) if the successful Bidder fails to:
    - (i) sign the Contract in accordance with ITT Clause 43;
    - (ii) furnish a Performance Security in accordance with ITT Clause 44.
- 21.6 The Bid Security or Bid- Securing Declaration of a JV must be in the name of the JV that submits the bid. If the JV has not been legally constituted at the time of bidding, the Bid Security or Bid-Securing Declaration shall be in the names of all future partners as named in the letter of intent mentioned in Section IV "Bidding Forms," Bidder Information Form Item 7.

# BIDDING DOCUMENT FOR THE PROCUREMENT OF POLYTECHNIC LABORATORY ITEM

---

21.7 If a bid security is **not required in the BDS**, and

- (a) if a Bidder withdraws its bid during the period of bid validity specified by the Bidder on the Letter of Bid Form, except as provided in ITT 20.2, or
- (b) if the successful Bidder fails to: sign the Contract in accordance with ITT 43; or furnish a performance security in accordance with ITT 44;

the Government may, **if provided for in the BDS**, declare the Bidder disqualified to be awarded a contract by the Government of the Maldives for a period of time **as stated in the BDS**.

## 22. Format and Signing of Bid

22.1 The Bidder shall prepare one original of the documents comprising the bid as described in ITT Clause 11 and clearly mark it "ORIGINAL." In addition, the Bidder shall submit copies of the bid, in the number specified in the **BDS** and clearly mark them "COPY." In the event of any discrepancy between the original and the copies, the original shall prevail.

22.2 The original and all copies of the bid shall be typed or written in indelible ink and shall be signed by a person duly authorized to sign on behalf of the Bidder.

22.3 Any interlineations, erasures, or overwriting shall be valid only if they are signed or initialled by the person signing the Bid.

## D. Submission and Opening of Bids

### 23. Submission, Sealing and Marking of Bids

23.1 Bidders may always submit their bids by mail or by hand. When so specified in the **BDS**, Bidders shall have the option of submitting their bids electronically.

- (a) Bidders submitting bids by mail or by hand, shall enclose the original and each copy of the Bid, including alternative bids, if permitted in accordance with ITT Clause 13, in separate sealed envelopes, duly marking the envelopes as "ORIGINAL" and "COPY." These envelopes containing the original and the copies shall then be enclosed in one single envelope. The rest of the procedure shall be in accordance with ITT sub-Clauses 23.2 and 23.3.
- (b) Bidders submitting bids electronically shall follow the electronic bid submission procedures specified in the **BDS**.

23.2 The inner and outer envelopes shall:

- (a) Bear the name and address of the Bidder;
- (b) be addressed to the Procuring Entity in accordance with ITT Sub-Clause 24.1;
- (c) bear the specific procurement reference number of this bidding process indicated in ITT 1.1 and any additional identification marks as **specified in the BDS**; and
- (d) bear a warning not to open before the time and date for bid opening, in accordance with ITT Sub-Clause 27.1.

23.3 If all envelopes are not sealed and marked as required, the Procuring Entity will assume no responsibility for the misplacement or premature opening of the bid.

### 24. Deadline for Submission of Bids

24.1 Bids must be received by the Procuring Entity at the address and no later than the date and time **specified in the BDS**.

24.2 The Procuring Entity may, at its discretion, extend the deadline for the submission of bids by

## **BIDDING DOCUMENT FOR THE PROCUREMENT OF POLYTECHNIC LABORATORY ITEM**

---

amending the Bidding Documents in accordance with ITT Clause 8, in which case all rights and obligations of the Procuring Entity and Bidders previously subject to the deadline shall thereafter be subject to the deadline as extended.

### **25. Late Bids**

25.1 The Procuring Entity shall not consider any bid that arrives after the deadline for submission of bids, in accordance with ITT Clause 24. Any bid received by the Procuring Entity after the deadline for submission of bids shall be declared late, rejected, and returned unopened to the Bidder.

### **26. Withdrawal, Substitution, and Modification of Bids**

- 26.1 A Bidder may withdraw, substitute, or modify its Bid after it has been submitted by sending a written notice in accordance with ITT Clause 23, duly signed by an authorized representative, and shall include a copy of the authorization (the power of attorney) in accordance with ITT Sub-Clause 22.2, (except that no copies of the withdrawal notice are required). The corresponding substitution or modification of the bid must accompany the respective written notice. All notices must be:
- (a) submitted in accordance with ITT Clauses 22 and 23 (except that withdrawal notices do not require copies), and in addition, the respective envelopes shall be clearly marked “WITHDRAWAL,” “SUBSTITUTION,” or “MODIFICATION;” and
  - (b) received by the Procuring Entity prior to the deadline prescribed for submission of bids, in accordance with ITT Clause 24.
- 26.2 Bids requested to be withdrawn in accordance with ITT Sub-Clause 26.1 shall be returned unopened to the Bidders.
- 26.3 No bid may be withdrawn, substituted, or modified in the interval between the deadline for submission of bids and the expiration of the period of bid validity specified by the Bidder on the Bid Submission Form or any extension thereof.

### **27. Bid Opening**

- 27.1 The Procuring Entity shall conduct the bid opening in public at the address, date and time **specified in the BDS**. Any specific electronic bid opening procedures required if electronic bidding is permitted in accordance with ITT Sub-Clause 23.1, shall be as **specified in the BDS**.
- 27.2 First, envelopes marked “WITHDRAWAL” shall be opened and read out and the envelope with the corresponding bid shall not be opened, but returned to the Bidder. If the withdrawal envelope does not contain a copy of the “power of attorney” confirming the signature as a person duly authorized to sign on behalf of the Bidder, the corresponding bid will be opened. No bid withdrawal shall be permitted unless the corresponding withdrawal notice contains a valid authorization to request the withdrawal and is read out at bid opening. Next, envelopes marked “SUBSTITUTION” shall be opened and read out and exchanged with the corresponding Bid being substituted, and the substituted Bid shall not be opened, but returned to the Bidder. No Bid substitution shall be permitted unless the corresponding substitution notice contains a valid authorization to request the substitution and is read out at bid opening. Envelopes marked “MODIFICATION” shall be opened and read out with the corresponding Bid. No Bid modification shall be permitted unless the corresponding modification notice contains a valid authorization to request the modification and is read out at Bid opening. Only envelopes that are opened and read out at Bid opening shall be considered further.
- 27.3 All other envelopes shall be opened one at a time, reading out: the name of the Bidder and whether there is a modification; the Bid Prices, including any discounts and alternative offers; the presence of a Bid Security or Bid-Securing Declaration, if required; and any other details as



# **BIDDING DOCUMENT FOR THE PROCUREMENT OF POLYTECHNIC LABORATORY ITEM**

---

the Procuring Entity may consider appropriate. Only discounts and alternative offers read out at Bid opening shall be considered for evaluation. No Bid shall be rejected at Bid opening except for late bids, in accordance with ITT Sub-Clause 25.1.

- 27.4 The Procuring Entity shall prepare a record of the Bid opening that shall include, as a minimum: the name of the Bidder and whether there is a withdrawal, substitution, or modification; the Bid Price, per lot if applicable, including any discounts, and alternative offers if they were permitted; and the presence or absence of a Bid Security or Bid-Securing Declaration, if one was required. The Bidders' representatives who are present shall be requested to sign the attendance sheet. A copy of the record shall be distributed to all Bidders who submitted bids in time, and posted online when electronic bidding is permitted.

## **E. Evaluation and Comparison of Bids**

### **28. Confidentiality**

- 28.1 Information relating to the examination, evaluation, comparison, and post-qualification of bids, and recommendation of contract award, shall not be disclosed to Bidders or any other persons not officially concerned with such process until publication of the Contract Award.
- 28.2 Any effort by a Bidder to influence the Procuring Entity in the examination, evaluation, comparison, and post-qualification of the bids or contract award decisions may result in the rejection of its Bid.
- 28.3 Notwithstanding ITT Sub-Clause 28.2, from the time of bid opening to the time of Contract Award, if any Bidder wishes to contact the Procuring Entity on any matter related to the bidding process, it should do so in writing.

### **29. Clarification of Bids**

- 29.1 To assist in the examination, evaluation, comparison and post-qualification of the bids, the Procuring Entity may, at its discretion, ask any Bidder for a clarification of its Bid. Any clarification submitted by a Bidder in respect to its Bid and that is not in response to a request by the Procuring Entity shall not be considered. The Procuring Entity's request for clarification and the response shall be in writing. No change in the prices or substance of the Bid shall be sought, offered, or permitted, except to confirm the correction of arithmetic errors discovered by the Procuring Entity in the Evaluation of the bids, in accordance with ITT Clause 31.

### **30. Responsiveness of Bids**

- 30.1 The Procuring Entity's determination of a bid's responsiveness is to be based on the contents of the bid itself.
- 30.2 A substantially responsive Bid is one that conforms to all the terms, conditions, and specifications of the Bidding Documents without material deviation, reservation, or omission. A material deviation, reservation, or omission is one that:
- (a) affects in any substantial way the scope, quality, or performance of the Goods and Related Services specified in the Contract; or
  - (b) limits in any substantial way, inconsistent with the Bidding Documents, the Procuring Entity's rights or the Bidder's obligations under the Contract; or
  - (c) if rectified would unfairly affect the competitive position of other Bidders presenting substantially responsive bids.
- 30.3 If a bid is not substantially responsive to the Bidding Documents, it shall be rejected by the Procuring Entity and may not subsequently be made responsive by the Bidder by correction of the material deviation, reservation, or omission.

# **BIDDING DOCUMENT FOR THE PROCUREMENT OF POLYTECHNIC LABORATORY ITEM**

---

## **31. Nonconformities, Errors, and Omissions**

- 31.1 Provided that a Bid is substantially responsive, the Procuring Entity may waive any non-conformities or omissions in the Bid that do not constitute a material deviation.
- 31.2 Provided that a bid is substantially responsive, the Procuring Entity may request that the Bidder submit the necessary information or documentation, within a reasonable period of time, to rectify nonmaterial nonconformities or omissions in the bid related to documentation requirements. Such omission shall not be related to any aspect of the price of the Bid. Failure of the Bidder to comply with the request may result in the rejection of its Bid.
- 31.3 Provided that the Bid is substantially responsive, the Procuring Entity shall correct arithmetical errors on the following basis:
- (a) if there is a discrepancy between the unit price and the line item total that is obtained by multiplying the unit price by the quantity, the unit price shall prevail and the line item total shall be corrected, unless in the opinion of the Procuring Entity there is an obvious misplacement of the decimal point in the unit price, in which case the line item total as quoted shall govern and the unit price shall be corrected;
  - (b) if there is an error in a total corresponding to the addition or subtraction of subtotals, the subtotals shall prevail and the total shall be corrected; and
  - (c) if there is a discrepancy between words and figures, the amount in words shall prevail, unless the amount expressed in words is related to an arithmetic error, in which case the amount in figures shall prevail subject to (a) and (b) above.
- 31.4 If the Bidder that submitted the lowest evaluated Bid does not accept the correction of errors, its Bid shall be rejected.

## **32. Preliminary Examination of Bids**

- 32.1 The Procuring Entity shall examine the bids to confirm that all documents and technical documentation requested in ITT Clause 11 have been provided, and to determine the completeness of each document submitted.
- 32.2 The Procuring Entity shall confirm that the following documents and information have been provided in the Bid. If any of these documents or information is missing, the offer shall be rejected.
- (a) Bid Submission Form, in accordance with ITT Sub-Clause 12.1;
  - (b) Price Schedules, in accordance with ITT Sub-Clause 12.2;
  - (c) Bid Security or Bid Securing Declaration, in accordance with ITT Clause 21, if applicable.

## **33. Examination of Terms and Conditions; Technical Evaluation**

- 33.1 The Procuring Entity shall examine the Bid to confirm that all terms and conditions specified in the GCC and the SCC have been accepted by the Bidder without any material deviation or reservation.
- 33.2 The Procuring Entity shall evaluate the technical aspects of the Bid submitted in accordance with ITT Clause 18, to confirm that all requirements specified in Section VI, Schedule of Requirements of the Bidding Documents have been met without any material deviation or reservation.
- 33.3 If, after the examination of the terms and conditions and the technical evaluation, the Procuring Entity determines that the Bid is not substantially responsive in accordance with ITT Clause 30, it shall reject the Bid.

# BIDDING DOCUMENT FOR THE PROCUREMENT OF POLYTECHNIC LABORATORY ITEM

---

## 34. Conversion to Single Currency

- 34.1 For evaluation and comparison purposes, the Procuring Entity shall convert all bid prices expressed in amounts in various currencies into an amount in a single currency **specified in the BDS**, using the selling exchange rates established by the source and on the date **specified in the BDS**.

## 35. Domestic Preference

- 35.1 Domestic preference shall not be a factor in bid evaluation.

## 36. Evaluation of Bids

- 36.1 The Procuring Entity shall evaluate each bid that has been determined, up to this stage of the evaluation, to be substantially responsive.
- 36.2 To evaluate a Bid, the Procuring Entity shall only use all the factors, methodologies and criteria defined in ITT Clause 36. No other criteria or methodology shall be permitted.
- 36.3 To evaluate a Bid, the Procuring Entity shall consider the following:
- (a) evaluation will be done for Items or Lots, as **specified in the BDS**; and the Bid Price as quoted in accordance with clause 14;
  - (b) price adjustment for correction of arithmetic errors in accordance with ITT Sub-Clause 31.3;
  - (c) price adjustment due to discounts offered in accordance with ITT Sub-Clause 14.4;
  - (d) adjustments due to the application of the evaluation criteria **specified in the BDS** from amongst those set out in Section III, Evaluation and Qualification Criteria;
- 36.4 The Procuring Entity's evaluation of a bid will exclude and not take into account any allowance for price adjustment during the period of execution of the contract, if provided in the bid.
- 36.5 The Procuring Entity's evaluation of a bid may require the consideration of other factors, in addition to the Bid Price quoted in accordance with ITT Clause 14. These factors may be related to the characteristics, performance, and terms and conditions of purchase of the Goods and Related Services. The effect of the factors selected, if any, shall be expressed in monetary terms to facilitate comparison of bids, unless otherwise specified in Section III, Evaluation and Qualification Criteria. The factors, methodologies and criteria to be used shall be as specified in ITT 36.3 (d).
- 36.6 If so, **specified in the BDS**, these Bidding Documents shall allow Bidders to quote separate prices for one or more lots, and shall allow the Procuring Entity to award one or multiple lots to more than one Bidder. The methodology of evaluation to determine the lowest-evaluated lot combinations, is specified in Section III, Evaluation and Qualification Criteria.

## 37. Comparison of Bids

- 37.1 The Procuring Entity shall compare all substantially responsive bids to determine the lowest-evaluated bid, in accordance with ITT Clause 36.

## 38. Post qualification of the Bidder

- 38.1 The Procuring Entity shall determine to its satisfaction whether the Bidder that is selected as having submitted the lowest evaluated and substantially responsive bid is qualified to perform the Contract satisfactorily.
- 38.2 The determination shall be based upon an examination of the documentary evidence of the

## **BIDDING DOCUMENT FOR THE PROCUREMENT OF POLYTECHNIC LABORATORY ITEM**

---

Bidder's qualifications submitted by the Bidder, pursuant to ITT Clause 19.

- 38.3 An affirmative determination shall be a prerequisite for award of the Contract to the Bidder. A negative determination shall result in disqualification of the bid, in which event the Procuring Entity shall proceed to the next lowest evaluated bid to make a similar determination of that Bidder's capabilities to perform satisfactorily.

### **39. Procuring Entity's Right to Accept Any Bid, and to Reject Any or All Bids**

- 39.1 The Procuring Entity reserves the right to accept or reject any bid, and to annul the bidding process and reject all bids at any time prior to contract award, without thereby incurring any liability to Bidders.

## **F. Award of Contract**

### **40. Award Criteria**

- 40.1 The Procuring Entity shall award the Contract to the Bidder whose offer has been determined to be the lowest evaluated bid and is substantially responsive to the Bidding Documents, provided further that the Bidder is determined to be qualified to perform the Contract satisfactorily.

### **41. Procuring Entity's Right to Vary Quantities at Time of Award**

- 41.1 At the time the Contract is awarded, the Procuring Entity reserves the right to increase or decrease the quantity of Goods and Related Services originally specified in Section VI, Schedule of Requirements, provided this does not exceed the percentages **specified in the BDS**, and without any change in the unit prices or other terms and conditions of the bid and the Bidding Documents.

### **42. Notification of Award**

- 42.1 Prior to the expiration of the period of bid validity, the Procuring Entity shall notify the successful Bidder, in writing, that its Bid has been accepted.
- 42.2 Until a formal Contract is prepared and executed, the notification of award shall constitute a binding Contract.
- 42.3 The Procuring Entity shall publish on its public notice board the results identifying the bid and lot numbers and the following information: (i) name of each Bidder who submitted a Bid; (ii) bid prices as read out at bid opening; (iii) name and evaluated prices of each Bid that was evaluated; (iv) name of Bidders whose bids were rejected and the reasons for their rejection; and (v) name of the winning Bidder, and the price it offered, as well as the duration and summary scope of the contract awarded. After publication of the award, unsuccessful Bidders may request in writing to the Procuring Entity for a debriefing seeking explanations on the grounds on which their bids were not selected. The Procuring Entity shall promptly respond in writing to any unsuccessful Bidder who, after publication of contract award, requests a debriefing.
- 42.4 Upon the successful Bidder's furnishing of the signed Contract Form and performance security pursuant to ITT Clause 44, the Procuring Entity will promptly notify each unsuccessful Bidder and will discharge its bid security, pursuant to ITT Clause 21.4.
- 42.5 Any Bidder may seek administrative review, in accordance with Regulation 52 of the Financial Regulations, of an act or omission by a Procuring Entity, which it considers to be in breach of the Financial Regulations. Any application for review must be submitted in writing to the Accountable Officer of the Procuring Entity, within ten working days from the date the Bidder knew, or should have known, of the circumstances giving rise to the complaint. If the Accountable Officer does not issue a decision within ten days, or the Bidder is not satisfied with the decision, the Bidder may submit a complaint to the Procurement Policy Section.

## **BIDDING DOCUMENT FOR THE PROCUREMENT OF POLYTECHNIC LABORATORY ITEM**

---

### **43. Signing of Contract**

- 43.1 Promptly after notification, the Procuring Entity shall send the successful Bidder the Agreement and the Special Conditions of Contract.
- 43.2 Within twenty-eight (28) days of receipt of the Agreement, the successful Bidder shall sign, date, and return it to the Procuring Entity.
- 43.3 Notwithstanding ITT 43.2 above, in case signing of the Contract Agreement is prevented by any export restrictions attributable to the Government of the Republic of Maldives, or to the use of the products/goods, systems or services to be supplied, where such export restrictions arise from trade regulations from a country supplying those products/goods, systems or services, the Bidder shall not be bound by its bid, always provided, however, that the Bidder can demonstrate to the satisfaction of the Procuring Entity that signing of the Contract Agreement has not been prevented by any lack of diligence on the part of the Bidder in completing any formalities, including applying for permits, authorizations and licenses necessary for the export of the products/goods, systems or services under the terms of the Contract.

### **44. Performance Security**

- 44.1 Within twenty eight (28) days of the receipt of notification of award from the Procuring Entity, the successful Bidder, if required, shall furnish the Performance Security in accordance with the GCC, using for that purpose the 3 Form included in Section IX Contract forms, or another Form acceptable to the Procuring Entity. The Procuring Entity shall promptly notify the name of the winning Bidder to each unsuccessful Bidder and discharge the Bid Securities of the unsuccessful Bidders pursuant to ITT Sub-Clause 21.4.
- 44.2 Failure of the successful Bidder to submit the above-mentioned Performance Security or sign the Contract shall constitute sufficient grounds for the annulment of the award and forfeiture of the Bid Security or execution of the Bid-Securing Declaration. In that event the Procuring Entity may award the Contract to the next lowest evaluated Bidder, whose offer is substantially responsive and is determined by the Procuring Entity to be qualified to perform the Contract satisfactorily.

## Section II. Bid Data Sheet (BDS)

The following data shall complement, supplement, or amend the provisions in the Instructions to Bidders (ITT) in Section I. Whenever there is a conflict, the provisions herein shall prevail over those in ITT.

ITT Clause Reference	Bid data that supplements the ITT
	<b>A. General</b>
<b>ITT 1.1</b>	The Procuring Entity is: Maldives: Enhancing Employability and Resilience of youth project. Project Management unit Ministry of Higher Education Fen Building, 2nd Floor Male', Maldives
<b>ITT 1.1</b>	The name and identification number of the Invitation for Bids are: Supply, delivery and installation of Laboratory Equipment at Maldives Polytechnic.
<b>ITT 4.4</b>	A list of firms suspended from participating in Government funded projects is available at <a href="http://www.finance.gov.mv">http://www.finance.gov.mv</a>
	<b>B. Contents of Bidding Documents</b>
<b>ITT 7.1</b>	For <b>clarification of bid purposes</b> only, the Procuring Entity's address is: Attention: <b>Mohamed Manaah Ahmed, Procurement Specialist</b> Address: Project Management unit, Fen Building, 2 <sup>nd</sup> Floor , <b>Ameenee Magu</b> City: <b>Male'</b> Post Code: <b>2005</b> Country: <b>Maldives</b> Telephone: <b>+960 3026975</b> Facsimile number: - Electronic mail address: <a href="mailto:mohamed.manaan@mohe.gov.mv">mohamed.manaan@mohe.gov.mv</a> The bidders can send written queries via email to <a href="mailto:Mohamed.manaan@mohe.v">Mohamed.manaan@mohe.v</a> before 12:00hrs, 31 <sup>th</sup> December 2019

**BIDDING DOCUMENT FOR THE PROCUREMENT OF POLYTECHNIC  
LABORATORY ITEM**

ITT Clause Reference	Bid data that supplements the ITT
	<b>C. Preparation of Bids</b>
ITT 10.1	The language of the bid is: <b>English</b>
ITT 11.1 (h)	The Bidder shall submit the following additional documents in its bid: <ul style="list-style-type: none"> <li>(a) <b>Company Registration Certificate</b></li> <li>(b) <b>Certification of local/ tax registration (GST)</b></li> <li>(c) <b>Pension Registration Certificate</b></li> <li>(d) <b>Tax Clearance Report obtained from MIRA dated no earlier than 20 days prior to the bid submission dates.</b></li> <li>(e) <b>Authorized Dealership Certificate of Letter from the OEM/Manufacturers Authorization Letter</b></li> <li>(f) <b>Technical experience and certification of the staff to carry out necessary after sales services.</b></li> </ul>
ITT 13.1	Alternative Bids shall <b>not</b> be considered.
ITT 14.5	The Incoterms edition is: <b>2010</b>
ITT 14.6	<b>Additionally, cost of goods should include price installation and testing</b>
ITT 14.6) (a)(b)	“Final destinations”: <b>In accordance with ITT 14.6</b>
ITT 14.7	The prices quoted by the Bidder shall <b>not</b> be adjustable.
ITT 14.8	Prices quoted for each lot shall correspond at least to 100 % of the items specified for each lot.
ITT 15.1	<u>The Bidder is required to quote entirely in <b>Maldivian Rufiyaa.</b></u>
ITT 18.3	Period of time the Goods are expected to be functioning: <b>Minimum two years after acceptance of the goods</b>
ITT 19.1 (a)	Manufacturer’s authorization is: <b>Required</b>
ITT 19.1 (b)	After sales service is: <b>Required</b>
ITT 20.1	The bid validity period shall be <b>90 days</b> from the day of bid opening

**BIDDING DOCUMENT FOR THE PROCUREMENT OF POLYTECHNIC  
LABORATORY ITEM**

ITT Clause Reference	Bid data that supplements the ITT
ITT 21.1	<b>Bids shall include a Bid Security in the form of Bank Guarantee (must be valid up to 31<sup>st</sup> January 2020) or Bank Certified Cheque.</b>
ITT 21.2	The amount of the Bid Security shall be: <b>MVR 10,000.00</b>
ITT 21.7	If the Bidder incurs any of the actions prescribed in subparagraphs (a) or (b) of this provision, the Government will suspend the Bidder from participation in public procurement for a period of 1 year.
ITT 22.1	In addition to the original of the bid, the number of copies is: <b>Zero.</b>
<b>D. Submission and Opening of Bids</b>	
ITT 23.1(b)	Bidders shall <b>not</b> have the option of submitting their bids electronically.
ITT 23.2 (c)	The inner and outer envelopes shall bear the following additional identification marks:  Supply, delivery and installation of Laboratory Equipment <b>at Maldives Polytechnic</b>  <b>Iulaan No:(IUL)475/475/2019/208</b>
ITT 24.1	For bid submission purposes, the Procuring Entity's address is: Attention: <b>Project Management unit</b> Address: <b>2nd Floor, Fen Building, Ameenee Magu</b> City: <b>Male'</b> Country: <b>Maldives</b> The deadline for the submission of bids is: Date: <b>08<sup>th</sup> January 2020</b> Time: <b>11:00</b>
ITT 27.1	The bid opening shall take place at: Address: <b>Project Management unit, 2nd Floor, Fen Building, Ameenee Magu</b> City: <b>Male'</b> Country: <b>Maldives</b> Date: <b>08<sup>th</sup> January 2020</b> Time: <b>11:00 am</b>
<b>E. Evaluation and Comparison of Bids</b>	
ITT 34.1	Bid prices should be in: <b>Maldivian Rufiyaa.</b>



**BIDDING DOCUMENT FOR THE PROCUREMENT OF POLYTECHNIC  
LABORATORY ITEM**

ITT Clause Reference	Bid data that supplements the ITT
<b>ITT 36.3(a)</b>	Evaluation will be done for <b>all the items together as one bid.</b> <i>Bidders shall bid for all the items in 100% quantity and the evaluation shall be carried out for all the items indicated in the Schedule of Requirements as one bid.</i>
<b>ITT 36.3(d)</b>	The adjustments shall be determined using the following criteria, from amongst those set out in Section III, Evaluation and Qualification Criteria:  (a) Delivery schedule: <b>Yes</b> (b) Deviation in payment schedule: <b>No</b> (c) the cost of major replacement components, mandatory spare parts, and service: <b>No</b> (d) the availability in the Republic of Maldives of spare parts and after-sales services for the facilities offered in the bid: <b>Yes</b> (e) the projected operating and maintenance costs during the life of the equipment: <b>No</b> (f) the performance and productivity of the equipment offered: <b>No</b>
<b>ITT 36.6</b>	<b>Not Applicable</b>
	<b>F. Award of Contract</b>
<b>ITT 41.1</b>	The maximum percentage by which quantities may be increased is: <b>10%</b>  The maximum percentage by which quantities may be decreased is: <b>10%</b>
<b>ITT 44.1</b>	<b>Successful bidders shall furnish the performance security amount into 5% of the contract price within 14 days of receiving notification of award.</b>

## Section III. Evaluation and Qualification Criteria

### Section III: Contents

1. Evaluation Criteria (ITT 36.3 (d))
3. Post qualification Requirements (ITT 38.2)

#### 1. Evaluation Criteria (ITT 36.3 (d))

The Procuring Entity's evaluation of a bid may take into account, in addition to the Bid Price quoted in accordance with ITT Clause 14.6, one or more of the following factors as specified in ITT Sub-Clause 36.3(d) and in BDS referring to ITT 36.3(d), using the following criteria and methodologies.

- (a) Delivery schedule. **Applicable**
- (b) Deviation in payment schedule. **Not Applicable**
- (c) Cost of major replacement components, mandatory spare parts, and service. **Not Applicable**
- (d) Availability in the Republic of Maldives of spare parts and after sales services for equipment offered in the bid. **Applicable**

An adjustment equal to the cost of the Procuring Entity of establishing the minimum service facilities and parts inventories, as outlined in BDS Sub-Clause 36.3(d), if quoted separately, shall be added to the bid price, for evaluation purposes only.

- (e) Projected operating and maintenance costs. **Not Applicable**
- (f) Performance and productivity of the equipment. **Not Applicable**

**3. Post qualification Requirements (ITT 38.2)**

After determining the lowest-evaluated bid in accordance with ITT Sub-Clause 37.1, the Procuring Entity shall carry out the post qualification of the Bidder in accordance with ITT Clause 38, using only the requirements specified. Requirements not included in the text below shall not be used in the evaluation of the Bidder's qualifications.

(a) Financial Capability

The Bidder shall furnish documentary evidence that it meets the following financial requirement(s):

- I. Certificate of Business Registration**
- II. Audited Financial Statements for the last three years.**
- III. Latest Bank Statement dated no earlier than 30 days prior to submission date**

(b) Experience and Technical Capacity

The Bidder shall furnish documentary evidence to demonstrate that it meets the following experience requirement(s):

**Supplied the required items in the past three years similar in nature to the requirement under this contract (Please attach copies of work Completion Certificates).**

The Bidder must provide the information indicated on the following Qualification forms to demonstrate that they meet the requirements for post qualification:

Post Qual I Form - Annual Turnover data for the past three years

Post Qual III Form - Financial Data for the past three years

Post Qual IV Form - Experience of contracts of a similar nature value under consideration, in the last three years.

**Post Qual Form I – Annual Turnover data**

*{All Bidders and partners of a joint venture must complete the information in this form. The information supplied should be the annual turnover of the Bidder (or each member of joint venture), the terms of the amounts billed to the clients for each year for work in progress or completed at the end of the period reported. Use a separate sheet for each partner of a joint venture}.*

<b>Annual turnover data for the last three years</b>	
<b>Year</b>	<b>Turnover</b>
2018	
2017	
2016	

**Qual Form III – Financial Data**

*{All Bidders and partners of a joint venture, should provide financial information to demonstrate that they meet the requirements for prequalification. Each applicant or partner of a joint venture must fill in this form. If necessary, use separate sheets to provide complete banker information. A copy of the audited balance sheet for each of the last three years should be attached}.*

<b>Banker details:</b>	
Name of Banker: .....	
Address of Banker: .....	
Telephone: .....	Contact name and title: .....
Facsimile: .....	Email: .....

**Summary of actual assets and liabilities for the previous three years**

Financial information	Previous three years		
	2016	2017	2018
1. Total assets			
2. Current assets			
3. Total liabilities			
4. Current liabilities			

**Specify proposed sources of credit line to meet the cash flow demands of the Project.**

Source of credit line	Amount
1.	
2	

*Attach audited financial statement for the last three years (for the individual applicant or each partner). Firms owned by individuals, and partnerships, may submit their balance sheets certified by a registered accountant.*

---

**Post Qual Form IV – Experience of contracts of similar  
nature**

*List all contracts performed in the last three years, valued over the amount stated in Section III.  
Attach reference letters.*

<b>Description (&amp; scope) of Goods supplied</b>	<b>Name of Client &amp; Contact Person</b>	<b>Year of Completion</b>	<b>Currency &amp; Value of Contract</b>

## **Section IV. Bidding Forms**

### **Table of Forms**

Bidder Information Form.....	32
Joint Venture Partner Information Form.....	33
Bid Submission Form .....	34
Price Schedule: Goods delivered to nominated point in the Republic of Maldives. ....	37
Price and Completion Schedule - Related Services .....	39
Bid Security (Bank Guarantee).....	40
Bid Security (Bid Bond) .....	<b>Error! Bookmark not defined.</b>
Bid-Securing Declaration.....	<b>Error! Bookmark not defined.</b>
Manufacturer's Authorization.....	<b>Error! Bookmark not defined.</b>

## **Bidder Information Form**

*[The Bidder shall fill in this Form in accordance with the instructions indicated below. No alterations to its format shall be permitted and no substitutions shall be accepted.]*

Date: *[insert date (as day, month and year) of Bid Submission]*  
Procurement Reference No.: **EEDP/G.30**

Page \_\_\_\_\_ of \_\_\_\_\_ pages

1. Bidder's Legal Name	<i>{insert Bidder's legal name}</i>
2. In case of JV, legal name of each party:	<i>{insert legal name of each party in JV}</i>
3. Bidder's actual or intended Country of Registration:	<i>{insert actual or intended Country of Registration}</i>
4. Bidder's Year of Registration:	<i>{insert Bidder's year of registration}</i>
5. Bidder's Legal Address in Country of Registration:	<i>{insert Bidder's legal address in country of registration}</i>
<b>6. Bidder's Authorized Representative Information</b>	
Name:	<i>{insert Authorized Representative's name}</i>
Address:	<i>{insert Authorized Representative's Address}</i>
Telephone/Fax numbers:	<i>{insert Authorized Representative's telephone/fax numbers}</i>
Email Address:	<i>{insert Authorized Representative's email address}</i>
<p>7. Attached are copies of original documents of: <i>{check the box(es) of the attached original documents}</i></p> <p><input type="checkbox"/> Articles of Incorporation or Registration of firm named in 1, above.</p> <p><input type="checkbox"/> In case of JV, letter of intent to form JV or JV agreement.</p> <p><input type="checkbox"/> In case of government owned entity from the Republic of Maldives, documents establishing legal and financial autonomy and compliance with commercial law, in accordance with ITT Sub-Clause 4.5.</p>	



## Joint Venture Partner Information Form

*[The Bidder shall fill in this Form in accordance with the instructions indicated below].*

Date: *[insert date (as day, month and year) of Bid Submission]*

Procurement Reference No.: **EEDP/G.30**

Page \_\_\_ of \_\_\_ pages

1. Bidder's Legal Name:	<i>{insert Bidder's legal name}</i>
2. JV's Party legal name:	<i>{insert JV's Party legal name}</i>
3. JV's Party Country of Registration:	<i>{insert JV's Party country of registration}</i>
4. JV's Party Year of Registration:	<i>{insert JV's Part year of registration}</i>
5. JV's Party Legal Address in Country of Registration:	<i>{insert JV's Party legal address in country of registration}</i>
6. JV's Party Authorized Representative Information	
Name:	<i>{insert name of JV's Party authorized representative}</i>
Address:	<i>{insert address of JV's Party authorized representative}</i>
Telephone/Fax numbers:	<i>{insert telephone/fax numbers of JV's Party authorized representative}</i>
Email Address:	<i>{insert email address of JV's Party authorized representative}</i>
7. Attached are copies of original documents of: <i>{check the box(es) of the attached original documents}</i>	
<input type="checkbox"/> Articles of Incorporation or Registration of firm named in 2, above.	
<input type="checkbox"/> In case of government owned entity from the Republic of Maldives, documents establishing legal and financial autonomy and compliance with commercial law, in accordance with ITT Sub-Clause 4.5.	

## **Bid Submission Form**

*[The Bidder shall fill in this Form in accordance with the instructions indicated. No alterations to its format shall be permitted and no substitutions shall be accepted.]*

Date: *{insert date (as day, month and year) of Bid Submission}*

Procurement Reference No.: **EEDP/G.30**

To: **Maldives Enhancing Employability and Resilience of youth Project (MMRY)**  
**Ministry of Higher Education**  
**2<sup>ND</sup> Floor, Fen Building**  
**Male', Maldives**

We, the undersigned, declare that:

- (a) We have examined and have no reservations to the Bidding Documents, including Addenda No.: \_\_\_\_\_ *{insert the number and issuing date of each Addenda}*;
- (b) We offer to supply in conformity with the Bidding Documents and in accordance with the Delivery Schedules specified in the Schedule of Requirements the following Goods and Related Services \_\_\_\_\_ *{insert a brief description of the Goods and Related Services}*;
- (c) The total price of our Bid, excluding any discounts offered in item (d) below, is: \_\_\_\_\_ *{Insert the total bid price in words and figures, indicating the various amounts and the respective currencies}*;
- (d) The discounts offered and the methodology for their application are:  
**Discounts.** If our bid is accepted, the following discounts shall apply. \_\_\_\_\_ *{Specify in detail each discount offered and the specific item of the Schedule of Requirements to which it applies.}*  
**Methodology of Application of the Discounts.** The discounts shall be applied using the following method: \_\_\_\_\_ *{Specify in detail the method that shall be used to apply the discounts}*;
- (e) Our bid shall be valid for the period of time specified in ITT Sub-Clause 20.1, from the date fixed for the bid submission deadline in accordance with ITT Sub-Clause 24.1, and it shall remain binding upon us and may be accepted at any time before the expiration of that period;
- (f) If our bid is accepted, we commit to obtain a performance security in accordance with ITT Clause 44 and GCC Clause 18 for the due performance of the Contract;
- (g) We, including any subcontractors or suppliers for any part of the contract, have nationality from eligible countries \_\_\_\_\_ [insert the nationality of the Bidder, including that of all parties that comprise the Bidder, if the Bidder is a JV, and the nationality each subcontractor and supplier]
- (h) We are eligible in accordance with ITT Sub-Clause 4.2 and have no conflict of interest in accordance with ITT Sub-Clause 4.3;

**BIDDING DOCUMENT FOR THE PROCUREMENT OF POLYTECHNIC LABORATORY ITEM**

- (i) Our firm, its affiliates or subsidiaries—including any subcontractors or suppliers for any part of the contract - has not been suspended from public procurement by the Government, under the laws or official regulations of the Republic of Maldives, in accordance with ITT Sub-Clause 4.4;
- (j) The following commissions, gratuities, or fees have been paid or are to be paid with respect to the bidding process or execution of the Contract: [insert complete name of each Recipient, its full address, the reason for which each commission or gratuity was paid and the amount and currency of each such commission or gratuity]

Name of Recipient	Address	Reason	Amount
_____	_____	_____	_____
_____	_____	_____	_____
_____	_____	_____	_____
_____	_____	_____	_____

*{If none has been paid or is to be paid, indicate “none.”}*

- (k) We understand that this bid, together with your written acceptance thereof included in your notification of award, shall constitute a binding contract between us, until a formal contract is prepared and executed.
- (l) We understand that you are not bound to accept the lowest evaluated bid or any other bid that you may receive.

Signed: .....*{insert signature of authorised person}*

Name: .....*{insert complete name of person signing}*

In the capacity of: .....*{insert legal capacity of person signing}*

Duly authorized to sign the bid for and on behalf of .....*{insert complete name of Bidder}*

Date: ..... day of ..... *{DD/MM/YY}*

## **Price Schedule Forms**

*[The Bidder shall fill in these Price Schedule Forms in accordance with the instructions indicated. The list of line items in column 1 of the **Price Schedules** shall coincide with the List of Goods and Related Services specified by the Procuring Entity in the Schedule of Requirements.]*

**BIDDING DOCUMENT FOR THE PROCUREMENT OF POLYTECHNIC LABORATORY ITEM**

<b>Price Schedule: Goods delivered to nominated point in the Republic of Maldives.</b>						
<b>Date:</b> _____		<b>Procurement Ref No:</b> _____			<b>Page N°</b> ____ <b>of</b> ____	
<i>1</i>	<i>2</i>	<i>3</i>	<i>4</i>	<i>5</i>	<i>6</i>	<i>7</i>
<b>Line Item N°</b>	<b>Description of Goods</b>	<b>Country of Origin</b>	<b>Delivery Date</b>	<b>Quantity and physical unit</b>	<b>DDP Unit price Delivered to Final destination [multiple destinations] in accordance with ITT 14.6(a)</b>	<b>DDP Total price Delivered to Final Destination [multiple destinations] per line item (Col. 5 x 6)</b>
		<i>{insert country of origin of the Good}</i>	<i>{insert quoted delivery date as defined by Incoterms}</i>	<i>{insert number of units to be supplied and name of the physical unit}</i>	<i>{insert unit price delivered per unit}</i>	<i>{insert total delivered price per line item}</i>
<b>1</b>	<b><u>Lot 1,</u></b>					
	3D Printer & 3D Printer Filament			1		
	Digi IC Board			1		
	Engine stand			4		
	Motor Cycle Wheel Balancer & Tire Changer			1		
	Bi-Directional Full Systems Diagnostic Scan Tool			1		
	Automatic Air Suspension System Training Equipment			1		
	PC ELECTRONIC BOARD with PC-connection			1		
<b>2</b>	<b><u>Lot 2</u></b>					
	VRV Air condition system			1		

**BIDDING DOCUMENT FOR THE PROCUREMENT OF POLYTECHNIC LABORATORY ITEM**

3	<b><u>Lot 3</u></b>	1
	Professional four-post lifts for wheel alignment	1
	HP Tire Changer Wheel Changers Machine Balancer Rim Clamp Combo 560 680 with 1 Year Full Warranty	1
	Hybrid Cut-Away Trainer, Prius, Electrical Operation	1
4	<b><u>Lot 4</u></b>	
	AT-3002 Electronic Ignition Simulator	1
	Electronic Injection Multipoint System Panel	1
	Air conditioning and climate control system training board	1
	Maldives Polytechnic, Male	
<b>Total Bid Price including GST 6% DDP MVR (Goods delivered to final destination)</b>		
Name of Bidder <i>{insert complete name of Bidder}</i> Signature of Bidder <i>{signature of person signing the Bid}</i> Date <i>{Insert Date}</i>		

**BIDDING DOCUMENT FOR THE PROCUREMENT OF POLYTECHNIC LABORATORY ITEM**

<b>Price and Completion Schedule - Related Services</b>						
<b>Date:</b> _____		<b>Procurement Ref No:</b> _____			<b>Page N°</b> ____ <b>of</b> _____	
<i>1</i>	<i>2</i>	<i>3</i>	<i>4</i>	<i>5</i>	<i>6</i>	<i>7</i>
Service N°	Description of Services <sup>a)</sup>	Country of Origin	Service Period at place of Final destination	Quantity and physical unit	Unit price	Total Price per Service (Col. 5 x 6 or estimate)
		<i>{insert country of origin of the Services}</i>	<i>{insert period service will take at place of final destination - per Service}</i>	<i>{insert number of units to be supplied}</i>	<i>{insert unit price per Service}</i>	<i>{insert total price per services}</i>
				<b>Total Bid Price (Related services)</b>		
Name of Bidder <i>{insert complete name of Bidder}</i>		Signature of Bidder <i>{Signature of person signing the Bid}</i>		Date <i>{insert date}</i>		

Notes: a) Services described under column 2 must exclude inland transportation and other services required in the Republic of Maldives to convey the goods to their final destination (as those costs are included in the delivered price of the goods in previous Price Schedule).

## **Bid Security (Bank Guarantee)**

*The Issuing Bank shall fill in this Bank Guarantee Form in accordance with the instructions indicated.*

\_\_\_\_\_ *[Bank's Name, and Address of Issuing Branch or Office]*

**Beneficiary:** \_\_\_\_\_ *[Name and Address of Procuring Entity]*

**Date:** \_\_\_\_\_

**BID GUARANTEE No.:** \_\_\_\_\_

We have been informed that *[name of the Bidder]* (hereinafter called "the Bidder") has submitted to you its bid dated (hereinafter called "the Bid") for the execution of *[name of contract]* under Invitation for Bids No. *[Procurement Reference number]* ("the IFB").

Furthermore, we understand that, according to your conditions, bids must be supported by a bid guarantee.

At the request of the Bidder, we *[name of Bank]* hereby irrevocably undertake to pay you any sum or sums not exceeding in total an amount of *[amount in figures]* (*[amount in words]*) upon receipt by us of your first demand in writing accompanied by a written statement stating that the Bidder is in breach of its obligation(s) under the bid conditions, because the Bidder:

- (a) has withdrawn its Bid during the period of bid validity specified by the Bidder in the Form of Bid; or
- (b) having been notified of the acceptance of its Bid by the Procuring Entity during the period of bid validity, (i) fails or refuses to execute the Contract Form; or (ii) fails or refuses to furnish the performance security, if required, in accordance with the Instructions to Bidders.

This guarantee will expire: (a) if the Bidder is the successful Bidder, upon our receipt of copies of the contract signed by the Bidder and the performance security issued to you upon the instruction of the Bidder; or (b) if the Bidder is not the successful Bidder, upon the earlier of (i) our receipt of a copy of your notification to the Bidder of the name of the successful Bidder; or (ii) twenty-eight days after the expiration of the Bidder's Bid.

Consequently, any demand for payment under this guarantee must be received by us at the office on or before that date.

This guarantee is subject to the Uniform Rules for Demand Guarantees, ICC Publication No. 458.

\_\_\_\_\_  
*[signature(s)]*



## **Manufacturer's Authorization**

*[The Bidder shall require the Manufacturer to fill in this Form in accordance with the instructions indicated. This letter of authorization should be on the letterhead of the Manufacturer and should be signed by a person with the proper authority to sign documents that are binding on the Manufacturer. The Bidder shall include it in its bid, if so indicated in the **BDS**.]*

Date: *[insert date (as day, month and year) of Bid Submission]*

ICB No.: *EEDP/G.30*

Alternative No.: *[insert identification No if this is a Bid for an alternative]*

To: *[insert complete name of Purchaser]*

### **WHEREAS**

We *[insert complete name of Manufacturer]*, who are official manufacturers of *[insert type of goods manufactured]*, having factories at *[insert full address of Manufacturer's factories]*, do hereby authorize *[insert complete name of Bidder]* to submit a bid the purpose of which is to provide the following Goods, manufactured by us *[insert name and or brief description of the Goods]*, and to subsequently negotiate and sign the Contract.

We hereby extend our full guarantee and warranty in accordance with Clause 28 of the General Conditions of Contract, with respect to the Goods offered by the above firm.

Signed: *[insert signature(s) of authorized representative(s) of the Manufacturer]*

Name: *[insert complete name(s) of authorized representative(s) of the Manufacturer]*

Title: *[insert title]*

Dated on \_\_\_\_\_ day of \_\_\_\_\_, \_\_\_\_\_ *[insert date of signing]*

## **Section V. Eligible Countries**

### **Eligibility for the Provision of Goods in Public Procurement**

1. The Government of the Maldives permits firms and individuals from all countries to offer goods for publically funded contracts.
2. As an exception, firms of a Country or goods manufactured in a Country may be excluded if:
  - i) as a matter of law or official regulation, the Republic of Maldives prohibits commercial relations with that Country, or
  - ii) by an Act of Compliance with a Decision of the United Nations Security Council taken under Chapter VII of the Charter of the United Nations, the Republic of Maldives prohibits any import of goods from that Country or any payments to persons or entities in that Country.
2. For the information of Bidders, at the present time firms, goods and services from the following countries are excluded from this bidding:

<http://web.worldbank.org/external/default/main?theSitePK=84266&contentMDK=64069844&menuPK=116730&pagePK=64148989&piPK=64148984>

## **PART 2 – Supply Requirements**

## Section VI. Schedule of Requirements

### Contents

1. List of Goods and Delivery Schedule.....	45
2. List of Related Services and Completion Schedule .....	47
3. Technical Specifications and Compliance Schedule.....	48
4. Drawings .....	<b>Error! Bookmark not defined.</b>
5. Inspections and Tests.....	<b>Error! Bookmark not defined.</b>

**BIDDING DOCUMENT FOR THE PROCUREMENT OF POLYTECHNIC LABORATORY ITEM**

**1. List of Goods and Delivery Schedule**

*[The Purchaser shall fill in this table, with the exception of the column “Bidder’s offered Delivery date” to be filled by the Bidder]*

Line Item N°	Description of Goods	Quantity	Physical Unit	Final (Project Site) Destination as specified in BDS	Delivery (as per Incoterms) Date		
					Earliest Delivery Date	Latest Delivery Date	Bidder’s offered Delivery date <i>[to be provided by the bidder]</i>
1	3D Printer & Filament for 3D printer.	01		Maldives Polytechnic, Male	-	70 days from contract signing (to the final Destinations)	
2	Digi IC Board	01		Maldives Polytechnic, Male		70 days from contract signing (to the final Destinations)	
3	Engine stand	04		Maldives Polytechnic, Male	-	70 days from contract signing (to the final Destinations)	
4	Motor Cycle Wheel Balancer & Tire Changer	01		Maldives Polytechnic, Male		70 days from contract signing (to the final Destinations)	
5	Bi-Directional Full Systems Diagnostic Scan Tool	01		Maldives Polytechnic, Male		70 days from contract signing (to the final Destinations)	
6	Automatic Air Suspension System Training Equipment	01		Maldives Polytechnic, Male		70 days from contract signing (to the final Destinations)	

**BIDDING DOCUMENT FOR THE PROCUREMENT OF POLYTECHNIC LABORATORY ITEM**

7	PC ELECTRONIC BOARD with PC-connection	01		Maldives Polytechnic, Male		70 days from contract signing (to the final Destinations)	
8	VRV Air condition system	01		Maldives Polytechnic, Male		70 days from contract signing (to the final Destinations)	
9	Professional four-post lifts for wheel alignment	01		Maldives Polytechnic, Male		70 days from contract signing (to the final Destinations)	
10	HP Tire Changer Wheel Changers Machine Balancer Rim Clamp Combo	01		Maldives Polytechnic, Male		70 days from contract signing (to the final Destinations)	
11	AT-3002 Electronic Ignition Simulator	01		Maldives Polytechnic, Male		70 days from contract signing (to the final Destinations)	
12	Electronic Injection Multipoint System Panel	01		Maldives Polytechnic, Male		70 days from contract signing (to the final Destinations)	
13	Air conditioning and climate control system training board	01		Maldives Polytechnic, Male		70 days from contract signing (to the final Destinations)	

**2. List of Related Services and Completion Schedule**

<b>Service No</b>	<b>Description of Service</b>	<b>Quantity<sup>1</sup></b>	<b>Physical Unit</b>	<b>Place where Services shall be performed</b>	<b>Final Completion Date(s) of Services</b>

1. If applicable

### **3. Technical Specifications and Compliance Schedule**

#### **Lot Summary Sheet**

##### **Lot 1**

<b>Qty</b>	<b>Description</b>
1	3D Printer and 3D Printer Filament
1	Digi IC Board
4	Engine stand
1	Motor Cycle Wheel Balancer & Tire Changer
1	LAUNCH X431 V+ (Upgraded Version of X431 V PRO) Bi-Directional Full Systems Diagnostic Scan Tool 11 Reset Functions Key Coding, ECU Coding, ABS Bleeding, SAS, DPF, BMS, TPMS
1	Automatic Air Suspension System Training Equipment
1	PC ELECTRONIC BOARD with PC-connection (Type 1018.1 USB)

##### **Lot 2**

<b>Qty</b>	<b>Description</b>
1	VRV Air condition system



**BIDDING DOCUMENT FOR THE PROCUREMENT OF POLYTECHNIC LABORATORY  
ITEM**

---

---

**Lot 3**

<b>Qty</b>	<b>Description</b>
<b>1</b>	Professional four-post lifts for wheel alignment
<b>1</b>	HP Tire Changer Wheel Changers Machine Balancer Rim Clamp Combo 560 680 with 1 Year Full Warranty
<b>1</b>	<b>Hybrid Cut-Away Trainer, Prius, Electrical Operation</b>

**Lot 4**

<b>Qty</b>	<b>Description</b>
<b>1</b>	AT-3002 Electronic Ignition Simulator
<b>1</b>	Electronic Injection Multipoint System Panel
<b>1</b>	Air conditioning and climate control system training board

**BIDDING DOCUMENT FOR THE PROCUREMENT OF POLYTECHNIC LABORATORY ITEM**

---

**PC ELECTRONIC BOARD with PC-connection (Type 1018.1 USB)**

*The Goods and Related Services shall comply with following Technical Specifications and Standards:*

***Lot 1***

**3D Printer**

**Qty: 01**

Specifications

Printing Method	FDM
Print Dimensions	350*350*400mm
Display	4.3 inch
Print Accuracy	±0.1mm
Nozzle diameter	Standard 0.4mm
Nozzle Quantity	1
Nozzle temperature	≤260°C
Hot Bed Temperature	≤110°C
Working modes	online or TF cards are printed offline
File formats	STL、Obj、 and Slicing
Software	cura、 Repeti-Host、 Simplify 3D
Power parameters	Input:100-240V AC;Output:DC 24V 21A;Max25A
Printing Materials	PLA、 ABS、 Soft Glue、 Wooden、 Copper Containing、 Gradient, etc.
Consumables Diame	1.75mm
Net Weight	18.2KG
Machine Size	632*666*619mm
Gross weight	23.8KG
Package size	730*740*310mm

**3D Printer Filament**

**Qty: 01**

1KG PLA 1.75M (Black & White)

1KG ABS 1.75M (Black & White)

# BIDDING DOCUMENT FOR THE PROCUREMENT OF POLYTECHNIC LABORATORY ITEM

## Digi IC Board

Qty: 01

### Technical data

#### Mains connection

- 220 V AC ... 240 V AC / 115 V AC (110 V AC);  
ca. 30 VA; 50 ... 60 Hz

#### Signal source

- Output voltage and current: approx. 0 ... 5 V DC / 10 mA,  
short-circuit-proof

#### DC voltage source for internal power supply

- Output voltage and current: +5 V / 3 A, short-circuit-proof,  
also for power supply of the plugged IC components

#### DC voltage source for external units

- Output voltage and current: +5 V / 0,5 A, short-circuit-proof

#### Clock generator

- Frequency: 100 kHz

#### Frequency divider

- Frequencies: 10 kHz, 1 kHz, 100 Hz, 10 Hz, 1 Hz, 0.1 Hz

#### TTL level

- At all high and low jacks and on the clock generator,  
frequency divider, 7-segment display, coding switch,  
pushbutton, input keyboard and LED displays

#### Mechanical data

The front panel of the DIGI IC BOARD is made of 5 mm thick Laminate, matt blue in colour with white engraving representing the built-in function groups.

The rear of the Board is protected with a grey plastic cover. Its shape allows the Board to be placed at an ergonomically favourable angle for example on a table.

#### Dimensions and weights

- Board version (Type 3920): 532 x 297 x 110 mm (w x h x d);  
weight: approx. 3.5 kg
- Box version (Type 3920 and Type 3920.20):  
580 x 450 x 155 mm; weight: approx. 7 kg

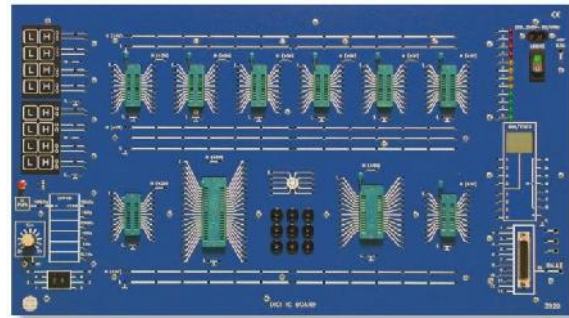

DIGI IC BOARD (Type 3920)

# BIDDING DOCUMENT FOR THE PROCUREMENT OF POLYTECHNIC LABORATORY ITEM

---

## **Engine stand**

**Qty: 04**

**Goplus Steel Rotating Engine Stand, 1000 lbs Capacity 360 Degree Head Motor Hoist, Auto Car Truck Automotive Jack**



### **Product description**

#### **Description**

1000lbs Engine Stand, which is designed to prevent tipping over while holding an engine block weighing up to 1250 lbs. This engine stand can provide a support structure that will secure the engine. You can use an engine hoist or crane to remove the engine from the vehicle, and then mount it to the face plate on this engine stand.

#### **Feature**

Heavy Duty Engine Stand  
Supports up to 1000 lb engine  
360 degree rotating head  
Faceplate has 4 adjustable arms  
Includes 2 rolling casters with 360° swivel for easy mobility  
Four adjustable arms for easy engine block mounting  
6 position locking pin  
Sturdy design prevents this engine stand from tipping while holding the block  
Ideal for storing or working on small blocks  
Assembly required

#### **Specifications**

Colour: Red  
Weight capacity:1000 lbs  
Wheel size:3"  
Face plate dimensions:10" L x 6" W  
Overall dimensions: 15.75"/31.5"(W) x 29.5"(D) x 33.5"

**BIDDING DOCUMENT FOR THE PROCUREMENT OF POLYTECHNIC LABORATORY ITEM**

**Motor Cycle Wheel Balancer & Tire Changer**

Qty: 01

Automotive	Inside Clamping Range	12" – 24" Will Mount Most 12" – 24" Wheels
	Outside Clamping Range	10" – 22" Should Mount Most 20" Wheels
Motorcycle	Reverted Clamping Range	12" – 24" (W-MC/ATV)
	Inverted Clamping Range	6" – 18" (W-MC/ATV)
Bead Breaker Range		3" – 15"
Maximum Tire Diameter		49"
Maximum Wheel Width		15"
Shipping Dimensions		47" × 36" × 72"
Weight		555Ibs
Product Dimensions		48"× 38" × 72"
Motor		1.5 HP
Power Requirement		220V / 50Hz / Single Phase / 20 amp
Compressor Requirement		150 – 175 psi
Included Accessories		Plastic shovel Protector Duckhead Protection Clamp Protection Tire Tool Lube Brush + Bucket
Optional Accessories		W-PL240 Assist Arm W-MC/ATV Tire Tool Protection Plastic Duckhead Bead Press Tool

# BIDDING DOCUMENT FOR THE PROCUREMENT OF POLYTECHNIC LABORATORY ITEM

## LAUNCH X431 V+ (Upgraded Version of X431 V PRO) Bi-Directional Full Systems Diagnostic Scan Tool 11 Reset Functions Key Coding, ECU Coding, ABS Bleeding, SAS, DPF, BMS, TPMS

Qty: 01



### Technical Details

Brand	LAUNCH
Model	LAUNCH X431 V+
Item Weight	13.23 pounds
Product Dimensions	13.8 x 5.9 x 9.8 inches
Item model number	LAUNCH X431 V+
Batteries	1 Lithium Polymer batteries required. (included)
Manufacturer Part Number	LAUNCH X431 V+
	No
	1*LAUNCH X431 V+
	<ul style="list-style-type: none"> <li>👉 Provides 5 YEARS WARRANTY</li> <li>, 😊 Bi-directional Control and Actuation Test</li> <li>, 😊 Diagnostics for Heavy-duty Trucks</li> <li>, 🔥 ECU Coding; Full-System Diagnostics</li> <li>, 🔥 Bluetooth Communication</li> <li>, 🔥 One-click Update via Wi-Fi</li> <li>, 💡 Remote Diagnosis</li> </ul>

[Folding](#)

[Cover Included](#)

[Special Features](#)

# BIDDING DOCUMENT FOR THE PROCUREMENT OF POLYTECHNIC LABORATORY ITEM

## Vehicle Service Type

- , 🔦 Data Printing, AutoSearch
- , 🛠️ Oil Reset Service, ABS Bleeding
- , 🛠️ Steering Angle Calibration, Electronic Parking Brake Reset
- , 🛠️ TPMS Reset, Battery Register /Battery Maintenance
- , 🛠️ Electronic Throttle Position Reset / Learn
- , 🛠️ Tooth Learning
- , 🛠️ Anti-theft Matching

**Aisa:** Changcheng, Daewoo, Huachen, Zhongxing, Indian Tata, JAC, Maruti, Perodua, Chery, Isuzu, Jinlong, Suzuki, Saipa, HM, Hmazda, Ikco, Malaysia Proton, Luxgen, Toyota, Changan, Futian, Honda, Wuling, V-class, Jpisuzu, Kia, Indian Maruti, Indian Mahindra, Malaysia Perodua, Hafei, Lifan, Mahindra, Nissan, Xiali, Zhongshun, Tata, Changhe, China GM, Saicmg, Mazda, Zhongtai, Daihatsu, BYD Flyer, Hyundai, Proton, Subaru, Ssangyong, Joylong, Mitsubishi, Gonow, Qoros, Maxus, Mvm

**Europe:** Vaz, Porsche, Maserati, BMW, Seat, VW, Audi, Citroen, Landrover, Smart, Renault, Skoda, Sprinter, Land Rover, Benz, Fiat, Opel, Volvo, Peugeot, Ferrari, Saab, Gaz, DR

**USA:** Gm, USAFord, Chrysler, Willy

**Australia:** Austford, Holden

**Brazil:** BXFiat, BXGM

---

**Automatic Air Suspension System Training Equipment**

**QTY: 01**



The Product The device is designed based on the Toyota lexus LS400 air suspension system to holistically demonstrate the structure and operation of air suspension. The device applies to theoretical teaching and maintenance training of the air suspension system in secondary and senior vocational skill schools, normal education and training institutions.

**Features**

- 1- A real and operable air suspension system is used to illustrate the structure of the system.
- 2- The height of air suspension and hardness of shock absorber are adjusted by operating the height controller or adjusting the suspension height or actuators, for example, the ECU compressor, height control solenoid valve, and shock absorber hardness controller. In this way, the device demonstrates operation of the air suspension system.
- 3- The training bench is made of advanced aluminum-plastic plate with characteristics of not less than 4mm thick, corrosion resistance, impact resistance, pollution resistance, fireproof, and moistureproof. Its surface are processed by special craft and spraying primer. Never fade color circuit diagram and working principal diagram are painted on the board whose surface coating with varnish. The trainees can learn and analyze the working principle of the control system by referencing the diagram and the real object.
- 4- The training bench is installed with detection terminals to detect electric signals, for example, resistance, voltage, current, and frequency, of circuit components of the air suspension system.
- 5- The training bench is installed with a fault indicator lamp and a diagnosis socket, which automatically diagnoses the system by blinking fault codes in case of short circuit.
- 6- The training bench's base frame is made in steel and the surface is paint-coated. Self-retention wheels are installed to ensure that the bench is flexible, reliable and endurable.
- 7- Equipped with intelligent fault setting and appraisal system, include fault setting, troubleshooting and assessment functions etc.



**BIDDING DOCUMENT FOR THE PROCUREMENT OF POLYTECHNIC LABORATORY  
ITEM**

---

**Basic Parameter**

- 1- Size: 1600mm × 1000mm × 1800mm (length x width x height)
- 2- External power supply: A.C. 220V ± 10% 50Hz
- 3- Operating voltage: 12V DC
- 4- Operating temperature: -40°C to +50°C

# BIDDING DOCUMENT FOR THE PROCUREMENT OF POLYTECHNIC LABORATORY ITEM

## PC ELECTRONIC BOARD with PC-connection (Type 1018.1 USB)

Qty: 01

### Technical Data

#### Mains connection

- Voltage: 230 V AC / 115 V AC (110 V AC)  
50 ... 60 Hz; approx. 70 VA

#### AC and DC voltages

- DC voltage: +15 V ( $\pm 5\%$ ); 800 mA  
- 15 V ( $\pm 5\%$ ); 800 mA  
+ 5 V; 100 mA  
0 ... 25 V; 300 mA
- AC voltage: 24 V AC; max. 100 mA

#### Function generator

- Sinewave / Squarewave / Triangal:  
 $U_{pp} = 0 \dots 20 \text{ V}; 100 \text{ mA}$   
 $f = 1 \text{ Hz} \dots 250 \text{ kHz}$   
 $R_i = 60 \Omega$
- Squarewave, positive:  
 $U = 5 \text{ V} / \text{TTL}$
- PWM: 10 kHz; Pulse width 0 ... 100 %
- DC Offset: +12 V ... -12 V

#### Three-phase current generator

- Phase voltage: 7 V<sub>eff</sub>
- Line voltage: 12 V<sub>eff</sub>
- Line current: max. 50 mA
- Frequency: approx. 50 Hz

The outputs of the function generator, DC and three-phase current sources are short-circuit-proof and LED-monitored.

#### Mechanical Data

The front panel of the PC ELECTRONIC BOARD is made of 5 mm thick laminate, matt blue in colour with white printing representing the built-in function groups. The rear of the Board is protected with a grey plastic cover. Its shape allows the Board to be placed at an ergonomically favourable angle for example on a table.

#### Dimensions and weights

- PC ELECTRONIC BOARD (Type 1018.1 USB):  
532 x 297 x 120 mm (w x h x d), weight: 3.9 kg
- Set of Accessories (Type 1018.11):  
532 x 297 x 150 mm (w x h x d), weight: 4.0 kg
- Box version, consisting of:  
PC ELECTRONIC BOARD (Type 1018.1 USB),  
Set of Accessories (Type 1018.11 and Type 1018.11.1)  
and Box (Type 1018.20): 580 x 450 x 200 mm
- total weight: 12 kg

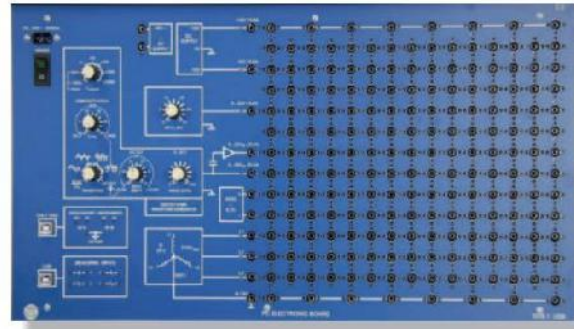

PC ELECTRONIC BOARD Type 1018.1 USB

### Accessories Required

- Set of Accessories (Type 1018.11), consisting of: storage board, resistors, capacitors, semiconductors, transformer coils
- Set of Accessories (Type 1018.11.1), consisting of: connecting leads and plugs
- Experiment manuals:  
Direct Current Technology (Type V 0101 4th Ed.)  
Alternating Current Technology (Type V 0102 4th Ed.)  
Semiconductor Components (Type V 0103 4th Ed.)  
Basic Electronic Circuits (Type V 0104 4th Ed.)
- Measuring interface (Type 1018.4)  
incl. measuring software to display measured data on a PC-monitor
- USB-Oscilloscope (Type 1018.5)  
incl. Software to view signals  
time or frequency based
- IC BOARD (Type 3530)  
for additional experiments with commercial components

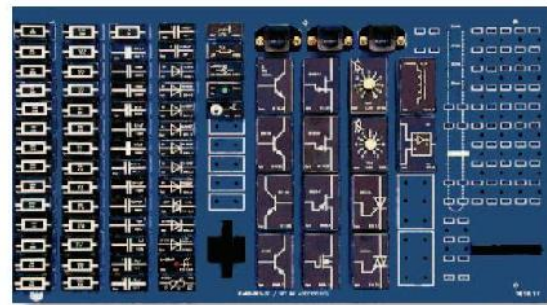

**BIDDING DOCUMENT FOR THE PROCUREMENT OF POLYTECHNIC LABORATORY ITEM**

***Lot 2***

**VRV Air condition system**

**Qty: 01**

<b>VRV Air-Condition System</b>	Outdoor Unit	Cooling capacity 10hp Voltage 3 phase 400v 50Hz Refrigerant R-410A	1
	Indoor Unit		
	Duct type	Cooling capacity 2hp, High Static Type Voltage single phase 220v Refrigerant R-410A	1
	Wall mount	Cooling capacity 2hp Voltage single phase 220v Refrigerant R-410A	1
	Ceiling cassette	Cooling capacity 2hp Voltage single phase 220v	1
	Joint Kit		3
	Digital Central Control		1
	Wired remote control		4
	Wireless Remote Control with receiver for duct Type AC		1
7- Daytimer		1	

***Lot 3***

**Professional four-post lifts for wheel alignment**

**Qty: 01**

Post wheel alignment lift

Hunter HawkEye Elite Four Camera Digital Imaging Wheel Aligner

Included in the System:

WinAlign Elite Software with WebSpecs

Hunter USB Keyboard for WinAlign operation

Remote Control

Optical Mouse

WA120E Wall / Column-Mount Cabinet with:

1 X Brake Pedal Depressor

1 X Steering Wheel Holder

Sensor-Vision system with 4 CMOS cameras

Fixed single-column assembly

Line conditioner

USH Hub

USB repeater

Mounting hardware

4 X Wheel Adaptors

4 X New Patented Targets

Target Supports

Convex Mirror

Turnplate Bridges to use with 40mm Turnplates Hawkeye HS401 Ride-Height Targets

Cables

UPS

**BIDDING DOCUMENT FOR THE PROCUREMENT OF POLYTECHNIC LABORATORY ITEM**

---

**HP Tire Changer Wheel Changers Machine Balancer Rim Clamp Combo 560 680.**

Qty: 01



Product Description:

**560 Semi Automatic Tire Changer Features:**

- 
- Rim clamping outside 10"-18" piston
- Rim clamping inside 12"-21" - Operating pressure 120-145 psi (8-10 bar)
- Motor Horsepower 1.5 HP Strong Motor - Voltage 110V only
- The bird head is designed with protector and claws are lifetime warranty - Includes 4 clamp protectors and Steel mount head(shown in picture)
- Maximum Tire Diameter 35" (900mm) - 500 lbs. Shipping Weight
- Maximum wheel Width 12" - Blue Powder Coat Finish
- Bead Break force 5600 lbs. pneumatic

**680 Electronic Wheel Balancer Features:**

- Rim diameter: 10" - 24"
- Rim width: 1.5" - 20"
- Max. wheel diameter: 44"(1117mm)
- Max. wheel weight: 155 lbs
- Pre set to American standard measurements
- cycle time: 6-9 seconds
- Balancing accuracy: -1g to +1g
- Noise: <70 dB
- Power supply: 110V
- Max. Power: 180-250W
- Standard Dynamic Mode, Static Mode, ALU 1-3 Mode, Motorcycle Mode
- includes 3 centering cones
- includes Quick Release Wing Nut
- includes all accessories shown in the pictures
- Blue Powder Coat Finish

# BIDDING DOCUMENT FOR THE PROCUREMENT OF POLYTECHNIC LABORATORY ITEM

---

## Hybrid Cut-Away Trainer, Prius, Electrical Operation

Qty: 01



### **SPECIFICATIONS:**

**Engine:** • Model: 1NZ-FXE • Type: Water cooled series, 4 cylinders • Valve: DOHC16 valves • Gross displacement: 1496 cc

**Motor:** • 3CM AC synchronous motor • Permanent magnet type synchronous motor

**Max Output:** • Engine: 77PS / 5,000 rpm • Motor: 68PS / 1,200~1,540 rpm

**Max Torque:** • Engine: 11.7kg-m / 4,200 rpm • Motor: 40.8 kg-m / 0~1,200 rpm

### **WEIGHT & DIMENSIONS:**

Size: 111cm x 81cm x 163cm (L x W x H)

Net Weight: 350 kg

Gross Weight: 470 kg

**HYBRID ELECTRIC VEHICLE TECHNOLOGY TEXTBOOK** Hybrid Electric Vehicle Technology provides foundational information about vehicles that use more than one propulsion technology to power a drive system. This textbook (279 pages) is filled with technical illustrations (197) and concise descriptions of the different configurations and vehicle platforms, the operation of various systems and the technology involved, and the maintenance of hybrid electric vehicles.

### **Content Highlights:**

- Introduction to HEV Technology
- Hybrid Engines
- Power Inverter Systems
- Electric Propulsion Sensing Systems
- Nickel-Metal Hydride Technology
- Hybrid Vehicle Braking Systems
- Textbook CD-ROM Includes: Quick Quizzes, Media Clips, Illustrated Glossary, Review Questions, and Flash Cards.

*Lot 4*

**AT-3002 Electronic Ignition Simulator**

Qty:01

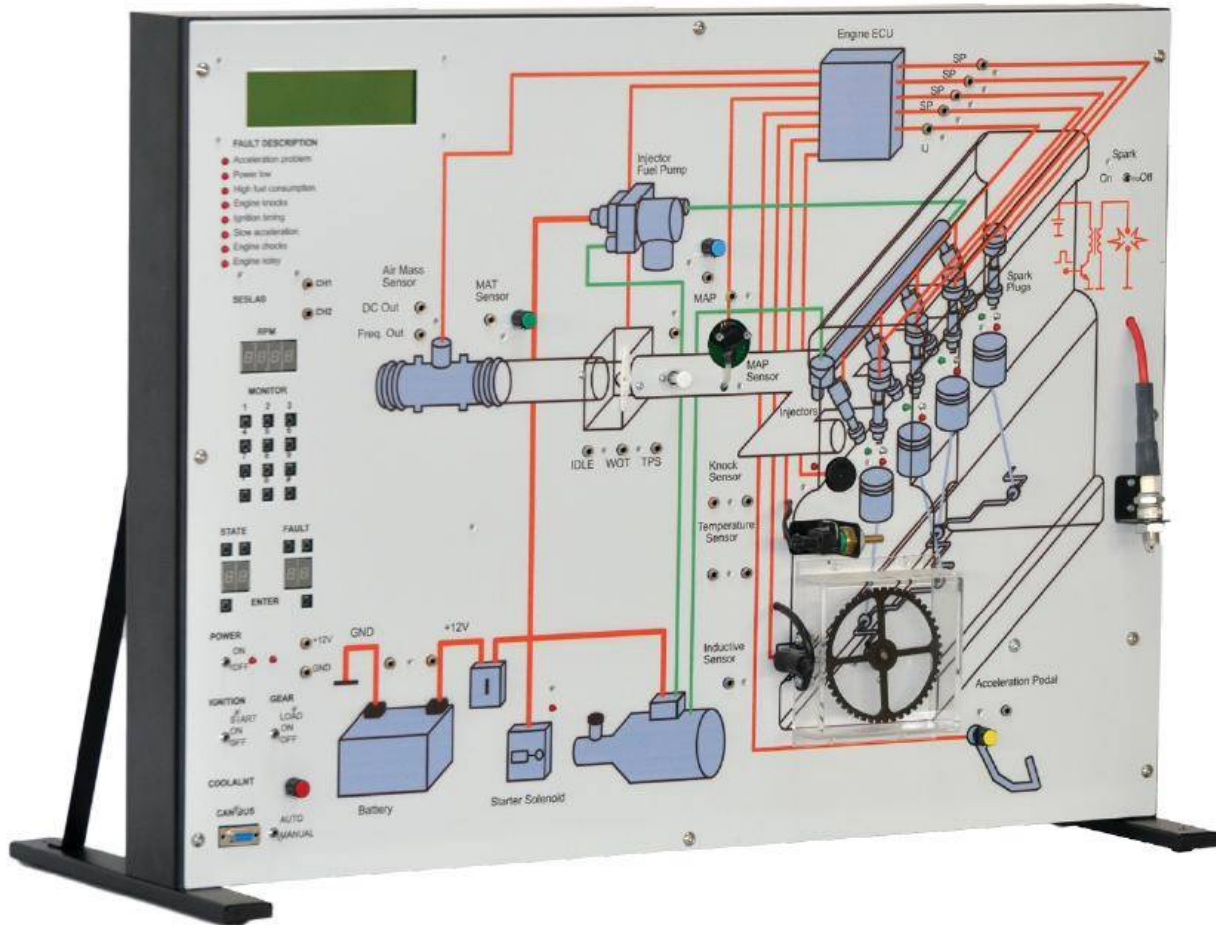

**TECHNICAL CHARACTERISTICS**

The Simulator is in a wide metal enclosure with a colored printed circuit experiment panel (80 x 60 x 10 cm), which ensures easy handling and good visibility of the components and the simulation part. The Simulator includes real components and simulation components modules. The experimenting panel includes the system drawings with test points and banana sockets. The Simulator can be operated as a stand-alone system without a PC, guided by experimental book using built in oscilloscope or an external oscilloscope. The Simulator can be connected to a PC in USB communication using CBT courseware and D-SCOPE software for signal display. A record of the student progress can be recorded on the student PC using the optional DCML software and can be accessed by the instructor for monitoring, course management and records if a local area network (not supplied) is available.

**THE SYSTEM INCLUDES**

# BIDDING DOCUMENT FOR THE PROCUREMENT OF POLYTECHNIC LABORATORY ITEM

---

- A power switch with indicating light
- D-SCOPE 2-channel digital oscilloscope
- 7 segment display and control switches, one for fault insertion unit and one for selecting simulation mode
- Eight (8) LED's to indicate troubleshooting state
- Status mode switches and display
- Warning indicating light
- Graphic and alphanumeric LCD display: 64X240 pixels
- Numeric keyboard
- CAN-BUS interface
- USB communication interface with the PC
- PC / MANUAL switch
- 12V Power adapter
- Digital multimeter
- Operating and simulation switches
- Simulation potentiometers
- Iron disk driven by DC motor
- Real crankshaft position sensor
- Ignition coils
- Spark plug firing sequence indicators
- Knock and MAP simulator sensors
- MAP simulator potentiometer
- Centralized injection system
- Real coolant temperature sensor
- Air temperature sensor simulation
- Temperature idle unit
- Electronic Distributorless Ignition System (DIS)

## **EXPERIMENTS**

This system enables the student to perform several experiments and covers the following topics:

- Centralized injection system
- Electronic ignition system type E-DIS
- Sparks producing and sparks not producing ignition
- Secondary circuit waveforms
- Triggering pulse
- Current restriction in primary circuit and ignition angle
- Ignition timing
- Engine revolution (speed) and ignition timing
- Engine load and ignition timing
- Engine temperature and ignition timing
- Knock control
- RPM measurements
- MAP sensor
- Sensors and valves system
- CAN-BUS communication

An experiment manual for the student and instructor manual accompany the system.

## **OPTIONAL ACCESSORIES**

- Personal computer with MS-Windows
- DCML (Degem Computer Managed Laboratory)



**Electronic Injection Multipoints System Panel**

**Qty: 01**



This trainer shows the functioning of a multi-point electronic injection system. It is mounted on a sturdy stand with wheels and easily allows you to:

- Regulate, by use of a pedal, the rpm from 0 to 2400.
- Effortlessly simulate the air pressure sensor in the collector as well as the water temperature.
- Generate sensor and actuator faults by disrupting the relative connections interface (standard with K line and 7 pins).
- Conveniently use and display this model because of its compact and inclusive design.

**SPECIFICATIONS:**

- Fuel Tank
- Fuel electro-pump
- Inlet fuel piping
- Electronic ECU injection-ignition
- Battery
- Feeding contractor system
- Fuel steams electro-valve
- Protection fuse of the injection-ignition system
- Activated carbon filter
- Diagnostic socket
- Absolute pressure and temperature sensor
- Rpm and PMS sensor
- Ignition spark plugs

- Cooling liquid temperature sensor
- Electro-injectors
- Positioning butterfly valve sensor
- Minimum rpm actuator
- Ignition coils
- Lambda probe (upstream)
- Lambda probe (downstream)
- Injection phase sensor
- On-off switch
- Feeding collector fuel
- OBD2 socket connection

**WEIGHT AND DIMENSIONS**

Size: 140cm x 70cm x 210cm (L x W x H)

Net Weight: 96 Kg

Gross Weight: 170 Kg

**Air conditioning and climate control system training board**

**Qty: 01**



**Order number: MSC1 (system with orifice tube)**

Fully functional air conditioning and climate control system trainer is installed in a mobile aluminium frame. This training board – simulator is specially designed to help technical students understand better electronic air conditioning and climate control system CLIMAtronic. The educational training board is based on Audi/VW OEM components. The integrated air conditioning and climate control system shows the different operation modes.

The training board-simulator is a great educational tool that allows students to learn the structure of air conditioning and climate control system, study its components, and perform various measurements, tests and other diagnostic procedures to use diagnostic scan tools or other special tools and equipment.

**Technical specifications and functions**

- Integrated electronic air conditioning system with climate control (Climatronic) and orifice tube;
- Monitoring operation modes of air conditioning and climate control system;
- Visible HVAC compressor, electromagnetic compressor clutch and its operation modes;
- With installed pressure gauges it is possible to monitor the pressure distribution of R134a refrigerant in the high and low pressure sides (circuits);
- Visible HVAC (heating, ventilating and air conditioning) mixing unit with its operation modes;
- Visible the operation of air flow flaps;
- Ability to monitor and control changes of the parameters of each system component:
  - The air flow fan speed
  - The air flow flap positions
  - The interior (inside) temperature
  - The refrigerant R134a pressure changes depending on the speed of the cooling radiator fan
  - The rate of the temperature change depending on the speed of the air flow radiator fan
  - The air flow flap position according to operation modes: defrost, air recirculation (fresh air) or footwell

## **BIDDING DOCUMENT FOR THE PROCUREMENT OF POLYTECHNIC LABORATORY ITEM**

---

- The training board has a diagram with LED's which shows the operation modes of the outlets and flaps;
- The training board has a complete electric wiring diagram with built – in banana plug jumpers for measurements and simulation of the system fault codes;
- Ability to simulate more than 15 system faults by disconnecting banana plug jumpers. Ability to monitor the changing operation mode of each system component;
- The training board has an integrated voltmeter. It displays voltage of electronic system components:
  - G92 Control motor potentiometer for temperature flap
  - G114 Control motor potentiometer, footwell/defroster flap
  - G112 Control motor potentiometer, central flap
  - G113 Control motor potentiometer, air flow flap
  - G89 Fresh air intake duct temperature sensor
  - G191 Vent. temperature sender, center
  - G192 Vent. temperature sender, footwell
  - G17 Ambient temperature sensor
- The integrated thermometer displays the temperature change depending on the pressure of the refrigerant R134a;

### **Diagnostic and measurement**

#### **Oscilloscope/multimeter**

- System's parameters are measured by connecting to the banana connector;
- Ability to measure electrical signal parameters of each system component (such as sensor or actuator)

#### **Control unit diagnosis (with the scan tool)**

- Diagnosis through OBD 16 – pin diagnostic connector
- Electronic control unit (ECU) identification
- Reading/erasing fault codes
- Displaying the operating system parameters (live data)
- Activating the actuators (depends on the control unit)
- Control unit encoding/configuration (depends on the control unit)

#### **Control unit diagnosis (manual procedures without the scan tool)**

- Manual diagnostics of Climatronic ECU
- Error reading – manual procedures
- Displaying the operating system parameters (live data) – manual procedure

## BIDDING DOCUMENT FOR THE PROCUREMENT OF POLYTECHNIC LABORATORY ITEM

---

### Other

- The stand has a closed structure – internal wiring is not visible
- Power supply: 220V
- Dimensions approx.: (HxLxW): 1680x800x500mm
- Nett weight approx.: 100 Kg
- Made in EU
- CE certificate

### Optional accessories

- Automotive oscilloscope
- OBD Diagnostic scan tool
- Air conditioning recharge station

The detailed technical evaluation will examine the technical specification of the items offered in column c and determine whether this meets the minimum specification in column b. Bidders must complete column c or their bid will be rejected. **Bidders are required to include technical literature to support the details provided in column c.**

**PART 3 - Contract**

## **Section VII. General Conditions of Contract**

### **Table of Clauses**

1. Definitions .....	71
2. Contract Documents .....	71
3. Fraud and Corruption .....	71
4. Interpretation .....	72
5. Language .....	73
6. Joint Venture, Consortium or Association .....	73
7. Eligibility .....	73
8. Notices .....	74
9. Governing Law .....	74
10. Settlement of Disputes .....	74
11. Inspections and Audit by the Government .....	74
12. Scope of Supply .....	74
13. Delivery and Documents .....	75
14. Supplier's Responsibilities .....	75
15. Contract Price .....	75
16. Terms of Payment .....	75
17. Taxes and Duties .....	75
18. Performance Security .....	76
19. Copyright .....	76
20. Confidential Information .....	76
21. Subcontracting .....	77
22. Specifications and Standards .....	77
23. Packing and Documents .....	77
24. Insurance .....	78
25. Transportation .....	78
26. Inspections and Tests .....	78
27. Liquidated Damages .....	79
28. Warranty .....	79
29. Patent Indemnity .....	79
30. Limitation of Liability .....	80
31. Change in Laws and Regulations .....	80
32. Force Majeure .....	81
33. Change Orders and Contract Amendments .....	81
34. Extensions of Time .....	81
35. Termination .....	82
36. Assignment .....	83
37. Export Restriction .....	83

## **Section VII. General Conditions of Contract**

### **1. Definitions**

1.1 The following words and expressions shall have the meanings hereby assigned to them:

- (a) “Completion” means the fulfilment of the Related Services by the Supplier in accordance with the terms and conditions set forth in the Contract.
- (b) “Contract” means the Contract Agreement entered into between the Procuring Entity and the Supplier, together with the Contract Documents referred to therein, including all attachments, appendices, and all documents incorporated by reference therein.
- (c) “Contract Documents” means the documents listed in the Contract Agreement, including any amendments thereto.
- (d) “Contract Price” means the price payable to the Supplier as specified in the Contract Agreement, subject to such additions and adjustments thereto or deductions there from, as may be made pursuant to the Contract.
- (e) “Day” means calendar day.
- (f) “GCC” means the General Conditions of Contract.
- (g) “Goods” means all of the commodities, raw material, machinery and equipment, and/or other materials that the Supplier is required to supply to the Procuring Entity under the Contract.
- (h) “Procuring Entity” means the entity purchasing the Goods and Related Services, as specified in the **SCC**.
- (i) “Related Services” means the services incidental to the supply of the goods, such as insurance, installation, training and initial maintenance and other such obligations of the Supplier under the Contract.
- (j) “SCC” means the Special Conditions of Contract.
- (k) “Subcontractor” means any natural person, private or government entity, or a combination of the above, to whom any part of the Goods to be supplied or execution of any part of the Related Services is subcontracted by the Supplier.
- (l) “Supplier” means the natural person, private or government entity, or a combination of the above, whose bid to perform the Contract has been accepted by the Procuring Entity and is named as such in the Contract Agreement.
- (m) “The Project Site,” where applicable, means the place named in the **SCC**.

### **2. Contract Documents**

2.1 Subject to the order of precedence set forth in the Contract Agreement, all documents forming the Contract (and all parts thereof) are intended to be correlative, complementary, and mutually explanatory. The Contract Agreement shall be read as a whole.

### **3. Fraud and Corruption**

3.1 If the Procuring Entity determines that the Supplier has engaged in corrupt, fraudulent,

# BIDDING DOCUMENT FOR THE PROCUREMENT OF POLYTECHNIC LABORATORY ITEM

---

collusive, coercive or obstructive practices, in competing for or in executing the Contract, then the Procuring Entity may, after giving 14 days notice to the Supplier, terminate the Supplier's employment under the Contract and cancel the contract, and the provisions of Clause 35 shall apply as if such expulsion had been made under Sub-Clause 35.1.

- (a) For the purposes of this Sub-Clause:
  - (i) "corrupt practice" is the offering, giving, receiving or soliciting, directly or indirectly, of anything of value to influence improperly the actions of another party;
  - (ii) "fraudulent practice" is any act or omission, including a misrepresentation, that knowingly or recklessly misleads, or attempts to mislead, a party to obtain a financial or other benefit or to avoid an obligation;
  - (iii) "collusive practice" is an arrangement between two or more parties designed to achieve an improper purpose, including to influence improperly the actions of another party;
  - (iv) "coercive practice" is impairing or harming, or threatening to impair or harm, directly or indirectly, any party or the property of the party to influence improperly the actions of a party;
  - (v) "obstructive practice" is
    - (a) deliberately destroying, falsifying, altering or concealing of evidence material to the investigation or making false statements to investigators in order to materially impede the Government's investigation into allegations of a corrupt, fraudulent, coercive or collusive practice; and/or threatening, harassing or intimidating any party to prevent it from disclosing its knowledge of matters relevant to the investigation or from pursuing the investigation; or
    - (b) acts intended to materially impede the exercise of the Government's inspection and audit rights provided for under Clause 11 [Inspections and Audits by the Government].

3.2 Should any employee of the Supplier be determined to have engaged in corrupt, fraudulent, collusive, coercive, or obstructive practice during the purchase of the Goods, then that employee shall be removed.

## 4. Interpretation

4.1 If the context so requires it, singular means plural and vice versa.

4.2 Incoterms

- (a) Unless inconsistent with any provision of the Contract, the meaning of any trade term and the rights and obligations of parties there under shall be as prescribed by Incoterms.
- (b) The terms EXW, CIP, FCA, CFR and other similar terms, when used, shall be governed by the rules prescribed in the current edition of Incoterms specified in the SCC and published by the International Chamber of Commerce in Paris, France.

4.3 Entire Agreement



# **BIDDING DOCUMENT FOR THE PROCUREMENT OF POLYTECHNIC LABORATORY ITEM**

---

The Contract constitutes the entire agreement between the Procuring Entity and the Supplier and supersedes all communications, negotiations and agreements (whether written or oral) of the parties with respect thereto made prior to the date of Contract.

## **4.4 Amendment**

No amendment or other variation of the Contract shall be valid unless it is in writing, is dated, expressly refers to the Contract, and is signed by a duly authorized representative of each party thereto.

## **4.5 Nonwaiver**

(a) Subject to GCC Sub-Clause 4.5(b) below, no relaxation, forbearance, delay, or indulgence by either party in enforcing any of the terms and conditions of the Contract or the granting of time by either party to the other shall prejudice, affect, or restrict the rights of that party under the Contract, neither shall any waiver by either party of any breach of Contract operate as waiver of any subsequent or continuing breach of Contract.

(b) Any waiver of a party's rights, powers, or remedies under the Contract must be in writing, dated, and signed by an authorized representative of the party granting such waiver, and must specify the right and the extent to which it is being waived.

## **4.6 Severability**

If any provision or condition of the Contract is prohibited or rendered invalid or unenforceable, such prohibition, invalidity or unenforceability shall not affect the validity or enforceability of any other provisions and conditions of the Contract.

## **5. Language**

5.1 The Contract as well as all correspondence and documents relating to the Contract exchanged by the Supplier and the Procuring Entity, shall be written in the language specified in the **SCC**. Supporting documents and printed literature that are part of the Contract may be in another language provided they are accompanied by an accurate translation of the relevant passages in the language specified, in which case, for purposes of interpretation of the Contract, this translation shall govern.

5.2 The Supplier shall bear all costs of translation to the governing language and all risks of the accuracy of such translation, for documents provided by the Supplier.

## **6. Joint Venture, Consortium or Association**

6.1 If the Supplier is a joint venture, consortium, or association, all of the parties shall be jointly and severally liable to the Procuring Entity for the fulfilment of the provisions of the Contract and shall designate one party to act as a leader with authority to bind the joint venture, consortium, or association. The composition or the constitution of the joint venture, consortium, or association shall not be altered without the prior consent of the Procuring Entity.

## **7. Eligibility**

7.1 The Supplier and its Subcontractors shall have the nationality of an eligible country. A Supplier or Subcontractor shall be deemed to have the nationality of a country if it is a citizen or constituted, incorporated, or registered, and operates in conformity with the provisions of the laws of that country.

## **BIDDING DOCUMENT FOR THE PROCUREMENT OF POLYTECHNIC LABORATORY ITEM**

---

7.2 All Goods and Related Services to be supplied under the Contract and funded by the Government shall have their origin in Eligible Countries. For the purpose of this Clause, origin means the country where the goods have been grown, mined, cultivated, produced, manufactured, or processed; or through manufacture, processing, or assembly, another commercially recognized article results that differs substantially in its basic characteristics from its components.

### **8. Notices**

8.1 Any notice given by one party to the other pursuant to the Contract shall be in writing to the address specified in the **SCC**. The term “in writing” means communicated in written form with proof of receipt.

8.2 A notice shall be effective when delivered or on the notice’s effective date, whichever is later.

### **9. Governing Law**

9.1 The Contract shall be governed by and interpreted in accordance with the laws of the Republic of Maldives, unless otherwise specified in the **SCC**.

### **10. Settlement of Disputes**

10.1 The Procuring Entity and the Supplier shall make every effort to resolve amicably by direct informal negotiation any disagreement or dispute arising between them under or in connection with the Contract.

10.2 If, after twenty-eight (28) days, the parties have failed to resolve their dispute or difference by such mutual consultation, then either the Procuring Entity or the Supplier may give notice to the other party of its intention to commence arbitration, as hereinafter provided, as to the matter in dispute, and no arbitration in respect of this matter may be commenced unless such notice is given. Any dispute or difference in respect of which a notice of intention to commence arbitration has been given in accordance with this Clause shall be finally settled by arbitration. Arbitration may be commenced prior to or after delivery of the Goods under the Contract. Arbitration proceedings shall be conducted in accordance with the rules of procedure **specified in the SCC**.

10.3 Notwithstanding any reference to arbitration herein,

(a) the parties shall continue to perform their respective obligations under the Contract unless they otherwise agree; and

(b) the Procuring Entity shall pay the Supplier any monies due the Supplier.

### **11. Inspections and Audit by the Government**

11.1 The Supplier shall permit the Government and/or persons appointed by the Government to inspect the Supplier’s offices and/or the accounts and records of the Supplier and its sub-contractors relating to the performance of the Contract, and to have such accounts and records audited by auditors appointed by the Government, if required by the Government. The Supplier’s attention is drawn to Clause 3, which provides, inter alia, that acts intended to materially impede the exercise of the Government’s inspection and audit rights provided for under Sub-Clause 11.1 constitute a prohibited practice subject to contract termination (as well as to a determination of suspension under Government Financial Regulations).

### **12. Scope of Supply**

# **BIDDING DOCUMENT FOR THE PROCUREMENT OF POLYTECHNIC LABORATORY ITEM**

---

12.1 The Goods and Related Services to be supplied shall be as specified in the Schedule of Requirements.

## **13. Delivery and Documents**

13.1 Subject to GCC Sub-Clause 33.1, the Delivery of the Goods and Completion of the Related Services shall be in accordance with the Delivery and Completion Schedule specified in the Schedule of Requirements. The details of shipping and other documents to be furnished by the Supplier are specified in the **SCC**.

## **14. Supplier's Responsibilities**

14.1 The Supplier shall supply all the Goods and Related Services included in the Scope of Supply in accordance with GCC Clause 12, and the Delivery and Completion Schedule, as per GCC Clause 13.

## **15. Contract Price**

15.1 Prices charged by the Supplier for the Goods supplied and the Related Services performed under the Contract shall not vary from the prices quoted by the Supplier in its bid, with the exception of any price adjustments authorized in the **SCC**.

## **16. Terms of Payment**

16.1 The Contract Price, including any Advance Payments, if applicable, shall be paid as specified in the **SCC**.

16.2 The Supplier's request for payment shall be made to the Procuring Entity in writing, accompanied by invoices describing, as appropriate, the Goods delivered and Related Services performed, and by the documents submitted pursuant to GCC Clause 13 and upon fulfilment of all other obligations stipulated in the Contract.

16.3 Payments shall be made promptly by the Procuring Entity, but in no case later than thirty (30) days after submission of an invoice or request for payment by the Supplier, and after the Procuring Entity has accepted it.

16.4 The currencies in which payments shall be made to the Supplier under this Contract shall be those in which the bid price is expressed.

16.5 In the event that the Procuring Entity fails to pay the Supplier any payment by its due date or within the period set forth in the **SCC**, the Procuring Entity shall pay to the Supplier interest on the amount of such delayed payment at the rate shown in the **SCC**, for the period of delay until payment has been made in full, whether before or after judgment or arbitration award.

## **17. Taxes and Duties**

17.1 Unless otherwise specified in the **SCC**, the Supplier shall be entirely responsible for all taxes, stamp duties, license fees, and other such levies imposed outside or within the Republic of Maldives until delivery of the contracted Goods to the Procuring Entity.

17.2 If any tax exemptions, reductions, allowances or privileges may be available to the Supplier in the Republic of Maldives, the Procuring Entity shall use its best efforts to enable the Supplier to benefit from any such tax savings to the maximum allowable extent.

## **BIDDING DOCUMENT FOR THE PROCUREMENT OF POLYTECHNIC LABORATORY ITEM**

---

### **18. Performance Security**

- 18.1 If required as specified in the SCC, the Supplier shall, within twenty-eight (28) days of the notification of contract award, provide a performance security for the performance of the Contract in the amount specified in the SCC.
- 18.2 The proceeds of the Performance Security shall be payable to the Procuring Entity as compensation for any loss resulting from the Supplier's failure to complete its obligations under the Contract.
- 18.3 As specified in the SCC, the Performance Security, if required, shall be denominated in the currency (ies) of the Contract, or in a freely convertible currency acceptable to the Procuring Entity; and shall be in one of the format stipulated by the Procuring Entity in the SCC, or in another format acceptable to the Procuring Entity.
- 18.4 The Performance Security shall be discharged by the Procuring Entity and returned to the Supplier not later than twenty-eight (28) days following the date of Completion of the Supplier's performance obligations under the Contract, including any warranty obligations, unless specified otherwise in the SCC.

### **19. Copyright**

- 19.1 The copyright in all drawings, documents, and other materials containing data and information furnished to the Procuring Entity by the Supplier herein shall remain vested in the Supplier, or, if they are furnished to the Procuring Entity directly or through the Supplier by any third party, including suppliers of materials, the copyright in such materials shall remain vested in such third party

### **20. Confidential Information**

- 20.1 The Procuring Entity and the Supplier shall keep confidential and shall not, without the written consent of the other party hereto, divulge to any third party any documents, data, or other information furnished directly or indirectly by the other party hereto in connection with the Contract, whether such information has been furnished prior to, during or following completion or termination of the Contract. Notwithstanding the above, the Supplier may furnish to its Subcontractor such documents, data, and other information it receives from the Procuring Entity to the extent required for the Subcontractor to perform its work under the Contract, in which event the Supplier shall obtain from such Subcontractor an undertaking of confidentiality similar to that imposed on the Supplier under GCC Clause 20.
- 20.2 The Procuring Entity shall not use such documents, data, and other information received from the Supplier for any purposes unrelated to the contract. Similarly, the Supplier shall not use such documents, data, and other information received from the Procuring Entity for any purpose other than the performance of the Contract.
- 20.3 The obligation of a party under GCC Sub-Clauses 20.1 and 20.2 above, however, shall not apply to information that:
  - (a) the Procuring Entity or Supplier need to share with other institutions participating in the financing of the Contract;
  - (b) now or hereafter enters the public domain through no fault of that party;
  - (c) can be proven to have been possessed by that party at the time of disclosure and which was not previously obtained, directly or indirectly, from the other party; or

## **BIDDING DOCUMENT FOR THE PROCUREMENT OF POLYTECHNIC LABORATORY ITEM**

---

- (d) otherwise lawfully becomes available to that party from a third party that has no obligation of confidentiality.

20.4 The above provisions of GCC Clause 20 shall not in any way modify any undertaking of confidentiality given by either of the parties hereto prior to the date of the Contract in respect of the Supply or any part thereof.

20.5 The provisions of GCC Clause 20 shall survive completion or termination, for whatever reason, of the Contract.

### **21. Subcontracting**

21.1 The Supplier shall notify the Procuring Entity in writing of all subcontracts awarded under the Contract if not already specified in the bid. Such notification, in the original bid or later shall not relieve the Supplier from any of its obligations, duties, responsibilities, or liability under the Contract.

21.2 Subcontracts shall comply with the provisions of GCC Clauses 3 and 7.

### **22. Specifications and Standards**

#### **22.1 Technical Specifications and Drawings**

- (a) The Goods and Related Services supplied under this Contract shall conform to the technical specifications and standards mentioned in Section VI, Schedule of Requirements and, when no applicable standard is mentioned, the standard shall be equivalent or superior to the official standards whose application is appropriate to the Goods' country of origin.
- (b) The Supplier shall be entitled to disclaim responsibility for any design, data, drawing, specification or other document, or any modification thereof provided or designed by or on behalf of the Procuring Entity, by giving a notice of such disclaimer to the Procuring Entity.
- (c) Wherever references are made in the Contract to codes and standards in accordance with which it shall be executed, the edition or the revised version of such codes and standards shall be those specified in the Schedule of Requirements. During Contract execution, any changes in any such codes and standards shall be applied only after approval by the Procuring Entity and shall be treated in accordance with GCC Clause 33.

### **23. Packing and Documents**

23.1 The Supplier shall provide such packing of the Goods as is required to prevent their damage or deterioration during transit to their final destination, as indicated in the Contract. During transit, the packing shall be sufficient to withstand, without limitation, rough handling and exposure to extreme temperatures, salt and precipitation, and open storage. Packing case size and weights shall take into consideration, where appropriate, the remoteness of the goods' final destination and the absence of heavy handling facilities at all points in transit.

23.2 The packing, marking, and documentation within and outside the packages shall comply strictly with such special requirements as shall be expressly provided for in the Contract, including additional requirements, if any, specified in the **SCC**, and in any other instructions ordered by the Procuring Entity.

## **BIDDING DOCUMENT FOR THE PROCUREMENT OF POLYTECHNIC LABORATORY ITEM**

---

### **24. Insurance**

- 24.1 Unless otherwise specified in the **SCC**, the Goods supplied under the Contract shall be fully insured—in a freely convertible currency from an eligible country—against loss or damage incidental to manufacture or acquisition, transportation, storage, and delivery, in accordance with the applicable Incoterms or in the manner specified in the **SCC**.

### **25. Transportation**

- 25.1 Unless otherwise specified in the **SCC**, responsibility for arranging transportation of the Goods shall be in accordance with the specified Incoterms.

### **26. Inspections and Tests**

- 26.1 The Supplier shall at its own expense and at no cost to the Procuring Entity carry out all such tests and/or inspections of the Goods and Related Services as are specified in the Schedule of Requirements.
- 26.2 The inspections and tests may be conducted on the premises of the Supplier or its Subcontractor, at point of delivery, and/or at the Goods' final destination, or in another place in the Republic of Maldives as specified in the Schedule of Requirements. Subject to GCC Sub-Clause 26.3, if conducted on the premises of the Supplier or its Subcontractor, all reasonable facilities and assistance, including access to drawings and production data, shall be furnished to the inspectors at no charge to the Procuring Entity.
- 26.3 The Procuring Entity or its designated representative shall be entitled to attend the tests and/or inspections referred to in GCC Sub-Clause 26.2, provided that the Procuring Entity bear all of its own costs and expenses incurred in connection with such attendance including, but not limited to, all travelling and board and lodging expenses.
- 26.4 Whenever the Supplier is ready to carry out any such test and inspection, it shall give a reasonable advance notice, including the place and time, to the Procuring Entity. The Supplier shall obtain from any relevant third party or manufacturer any necessary permission or consent to enable the Procuring Entity or its designated representative to attend the test and/or inspection.
- 26.5 The Procuring Entity may require the Supplier to carry out any test and/or inspection not required by the Contract but deemed necessary to verify that the characteristics and performance of the Goods comply with the technical specifications codes and standards under the Contract, provided that the Supplier's reasonable costs and expenses incurred in the carrying out of such test and/or inspection shall be added to the Contract Price. Further, if such test and/or inspection impedes the progress of manufacturing and/or the Supplier's performance of its other obligations under the Contract, due allowance will be made in respect of the Delivery Dates and Completion Dates and the other obligations so affected.
- 26.6 The Supplier shall provide the Procuring Entity with a report of the results of any such test and/or inspection.
- 26.7 The Procuring Entity may reject any Goods or any part thereof that fail to pass any test and/or inspection or do not conform to the specifications. The Supplier shall either rectify or replace such rejected Goods or parts thereof or make alterations necessary to meet the specifications at no cost to the Procuring Entity, and shall repeat the test and/or inspection, at no cost to the Procuring Entity, upon giving a notice pursuant to GCC Sub-Clause 26.4.
- 26.8 The Supplier agrees that neither the execution of a test and/or inspection of the Goods or any part thereof, nor the attendance by the Procuring Entity or its representative, nor the issue of any report pursuant to GCC Sub-Clause 26.6, shall release the Supplier from any warranties or

## **BIDDING DOCUMENT FOR THE PROCUREMENT OF POLYTECHNIC LABORATORY ITEM**

---

other obligations under the Contract.

### **27. Liquidated Damages**

27.1 Except as provided under GCC Clause 32, if the Supplier fails to deliver any or all of the Goods by the Date(s) of delivery or perform the Related Services within the period specified in the Contract, the Procuring Entity may without prejudice to all its other remedies under the Contract, deduct from the Contract Price, as liquidated damages, a sum equivalent to the percentage specified in the **SCC** of the delivered price of the delayed Goods or unperformed Services for each week or part thereof of delay until actual delivery or performance, up to a maximum deduction of the percentage specified in those **SCC**. Once the maximum is reached, the Procuring Entity may terminate the Contract pursuant to GCC Clause 35.

### **28. Warranty**

28.1 The Supplier warrants that all the Goods are new, unused, and of the most recent or current models, and that they incorporate all recent improvements in design and materials, unless provided otherwise in the Contract.

28.2 Subject to GCC Sub-Clause 22.1(b), the Supplier further warrants that the Goods shall be free from defects arising from any act or omission of the Supplier or arising from design, materials, and workmanship, under normal use in the conditions prevailing in the Maldives.

28.3 Unless otherwise specified in the **SCC**, the warranty shall remain valid for twelve (12) months after the Goods, or any portion thereof as the case may be, have been delivered to and accepted at the final destination indicated in the **SCC**, or for eighteen (18) months after the date of shipment from the port or place of loading in the country of origin, whichever period concludes earlier.

28.4 The Procuring Entity shall give notice to the Supplier stating the nature of any such defects together with all available evidence thereof, promptly following the discovery thereof. The Procuring Entity shall afford all reasonable opportunity for the Supplier to inspect such defects.

28.5 Upon receipt of such notice, the Supplier shall, within the period specified in the **SCC**, expeditiously repair or replace the defective Goods or parts thereof, at no cost to the Procuring Entity.

28.6 If having been notified, the Supplier fails to remedy the defect within the period specified in the **SCC**, the Procuring Entity may proceed to take within a reasonable period such remedial action as may be necessary, at the Supplier's risk and expense and without prejudice to any other rights which the Procuring Entity may have against the Supplier under the Contract.

### **29. Patent Indemnity**

29.1 The Supplier shall, subject to the Procuring Entity's compliance with GCC Sub-Clause 29.2, indemnify and hold harmless the Procuring Entity and its employees and officers from and against any and all suits, actions or administrative proceedings, claims, demands, losses, damages, costs, and expenses of any nature, including attorney's fees and expenses, which the Procuring Entity may suffer as a result of any infringement or alleged infringement of any patent, utility model, registered design, trademark, copyright, or other intellectual property right registered or otherwise existing at the date of the Contract by reason of:

- (a) the installation of the Goods by the Supplier or the use of the Goods in the Maldives; and

## **BIDDING DOCUMENT FOR THE PROCUREMENT OF POLYTECHNIC LABORATORY ITEM**

---

- (b) the sale in any country of the products produced by the Goods.

Such indemnity shall not cover any use of the Goods or any part thereof other than for the purpose indicated by or to be reasonably inferred from the Contract, neither any infringement resulting from the use of the Goods or any part thereof, or any products produced thereby in association or combination with any other equipment, plant, or materials not supplied by the Supplier, pursuant to the Contract.

- 29.2 If any proceedings are brought or any claim is made against the Procuring Entity arising out of the matters referred to in GCC Sub-Clause 29.1, the Procuring Entity shall promptly give the Supplier a notice thereof, and the Supplier may at its own expense and in the Procuring Entity's name conduct such proceedings or claim and any negotiations for the settlement of any such proceedings or claim.
- 29.3 If the Supplier fails to notify the Procuring Entity within twenty-eight (28) days after receipt of such notice that it intends to conduct any such proceedings or claim, then the Procuring Entity shall be free to conduct the same on its own behalf.
- 29.4 The Procuring Entity shall, at the Supplier's request, afford all available assistance to the Supplier in conducting such proceedings or claim, and shall be reimbursed by the Supplier for all reasonable expenses incurred in so doing.
- 29.5 The Procuring Entity shall indemnify and hold harmless the Supplier and its employees, officers, and Subcontractors from and against any and all suits, actions or administrative proceedings, claims, demands, losses, damages, costs, and expenses of any nature, including attorney's fees and expenses, which the Supplier may suffer as a result of any infringement or alleged infringement of any patent, utility model, registered design, trademark, copyright, or other intellectual property right registered or otherwise existing at the date of the Contract arising out of or in connection with any design, data, drawing, specification, or other documents or materials provided or designed by or on behalf of the Procuring Entity.

### **30. Limitation of Liability**

- 30.1 Except in cases of criminal negligence or wilful misconduct,
- (a) the Supplier shall not be liable to the Procuring Entity, whether in contract, tort, or otherwise, for any indirect or consequential loss or damage, loss of use, loss of production, or loss of profits or interest costs, provided that this exclusion shall not apply to any obligation of the Supplier to pay liquidated damages to the Procuring Entity and
- (b) the aggregate liability of the Supplier to the Procuring Entity, whether under the Contract, in tort or otherwise, shall not exceed the total Contract Price, provided that this limitation shall not apply to the cost of repairing or replacing defective equipment, or to any obligation of the supplier to indemnify the Procuring Entity with respect to patent infringement

### **31. Change in Laws and Regulations**

- 31.1 Unless otherwise specified in the Contract, if after the date of 28 days prior to date of Bid submission, any law, regulation, ordinance, order or bylaw having the force of law is enacted, promulgated, abrogated, or changed in the Republic of Maldives (which shall be deemed to include any change in interpretation or application by the competent authorities) that subsequently affects the Delivery Date and/or the Contract Price, then such Delivery Date and/or Contract Price shall be correspondingly increased or decreased, to the extent that the Supplier has thereby been affected in the performance of any of its obligations under the



## **BIDDING DOCUMENT FOR THE PROCUREMENT OF POLYTECHNIC LABORATORY ITEM**

---

Contract. Notwithstanding the foregoing, such additional or reduced cost shall not be separately paid or credited if the same has already been accounted for in the price adjustment provisions where applicable, in accordance with GCC Clause 15.

### **32. Force Majeure**

- 32.1 The Supplier shall not be liable for forfeiture of its Performance Security, liquidated damages, or termination for default if and to the extent that its delay in performance or other failure to perform its obligations under the Contract is the result of an event of Force Majeure.
- 32.2 For purposes of this Clause, “Force Majeure” means an event or situation beyond the control of the Supplier that is not foreseeable, is unavoidable, and its origin is not due to negligence or lack of care on the part of the Supplier. Such events may include, but not be limited to, acts of the Procuring Entity in its sovereign capacity, wars or revolutions, fires, floods, epidemics, quarantine restrictions, and freight embargoes.
- 32.3 If a Force Majeure situation arises, the Supplier shall promptly notify the Procuring Entity in writing of such condition and the cause thereof. Unless otherwise directed by the Procuring Entity in writing, the Supplier shall continue to perform its obligations under the Contract as far as is reasonably practical, and shall seek all reasonable alternative means for performance not prevented by the Force Majeure event.

### **33. Change Orders and Contract Amendments**

- 33.1 The Procuring Entity may at any time order the Supplier through notice in accordance GCC Clause 8, to make changes within the general scope of the Contract in any one or more of the following:
- (a) drawings, designs, or specifications, where Goods to be furnished under the Contract are to be specifically manufactured for the Procuring Entity;
  - (b) the method of shipment or packing;
  - (c) the place of delivery; and
  - (d) the Related Services to be provided by the Supplier.
- 33.2 If any such change causes an increase or decrease in the cost of, or the time required for, the Supplier’s performance of any provisions under the Contract, an equitable adjustment shall be made in the Contract Price or in the Delivery/Completion Schedule, or both, and the Contract shall accordingly be amended. Any claims by the Supplier for adjustment under this Clause must be asserted within twenty-eight (28) days from the date of the Supplier’s receipt of the Procuring Entity’s change order.
- 33.3 Prices to be charged by the Supplier for any Related Services that might be needed but which were not included in the Contract shall be agreed upon in advance by the parties and shall not exceed the prevailing rates charged to other parties by the Supplier for similar services.
- 33.4 Subject to the above, no variation in or modification of the terms of the Contract shall be made except by written amendment signed by the parties.

### **34. Extensions of Time**

- 34.1 If at any time during performance of the Contract, the Supplier or its subcontractors should encounter conditions impeding timely delivery of the Goods or completion of Related

## **BIDDING DOCUMENT FOR THE PROCUREMENT OF POLYTECHNIC LABORATORY ITEM**

---

Services pursuant to GCC Clause 13, the Supplier shall promptly notify the Procuring Entity in writing of the delay, its likely duration, and its cause. As soon as practicable after receipt of the Supplier's notice, the Procuring Entity shall evaluate the situation and may at its discretion extend the Supplier's time for performance, in which case the extension shall be ratified by the parties by amendment of the Contract.

- 34.2 Except in case of Force Majeure, as provided under GCC Clause 32, a delay by the Supplier in the performance of its Delivery and Completion obligations shall render the Supplier liable to the imposition of liquidated damages pursuant to GCC Clause 26, unless an extension of time is agreed upon, pursuant to GCC Sub-Clause 34.1.

### **35. Termination**

#### **35.1 Termination for Default**

- (a) The Procuring Entity, without prejudice to any other remedy for breach of Contract, by written notice of default sent to the Supplier, may terminate the Contract in whole or in part:
- (i) if the Supplier fails to deliver any or all of the Goods within the period specified in the Contract, or within any extension thereof granted by the Procuring Entity pursuant to GCC Clause 34;
  - (ii) if the Supplier fails to perform any other obligation under the Contract; or
  - (iii) if the Supplier, in the judgment of the Procuring Entity has engaged in fraud and corruption, as defined in GCC Clause 3, in competing for or in executing the Contract.
- (b) In the event the Procuring Entity terminates the Contract in whole or in part, pursuant to GCC Clause 35.1(a), the Procuring Entity may procure, upon such terms and in such manner as it deems appropriate, Goods or Related Services similar to those undelivered or not performed, and the Supplier shall be liable to the Procuring Entity for any additional costs for such similar Goods or Related Services. However, the Supplier shall continue performance of the Contract to the extent not terminated.

#### **35.2 Termination for Insolvency.**

- (a) The Procuring Entity may at any time terminate the Contract by giving notice to the Supplier if the Supplier becomes bankrupt or otherwise insolvent. In such event, termination will be without compensation to the Supplier, provided that such termination will not prejudice or affect any right of action or remedy that has accrued or will accrue thereafter to the Procuring Entity

#### **35.3 Termination for Convenience.**

- (a) The Procuring Entity, by notice sent to the Supplier, may terminate the Contract, in whole or in part, at any time for its convenience. The notice of termination shall specify that termination is for the Procuring Entity's convenience, the extent to which performance of the Supplier under the Contract is terminated, and the date upon which such termination becomes effective.
- (b) The Goods that are complete and ready for shipment within twenty-eight (28) days after the Supplier's receipt of notice of termination shall be accepted by the Procuring Entity at the Contract terms and prices. For the remaining Goods, the Procuring Entity may

**BIDDING DOCUMENT FOR THE PROCUREMENT OF POLYTECHNIC  
LABORATORY ITEM**

---

elect:

- (i) to have any portion completed and delivered at the Contract terms and prices; and/or
- (ii) to cancel the remainder and pay to the Supplier an agreed amount for partially completed Goods and Related Services and for materials and parts previously procured by the Supplier.

**36. Assignment**

36.1 Neither the Procuring Entity nor the Supplier shall assign, in whole or in part, their obligations under this Contract, except with prior written consent of the other party.

**37. Export Restriction**

37.1 Notwithstanding any obligation under the Contract to complete all export formalities, any export restrictions attributable to the Procuring Entity, to the Republic of Maldives, or to the use of the products/goods, systems or services to be supplied, which arise from trade regulations from a country supplying those products/goods, systems or services, and which substantially impede the Supplier from meeting its obligations under the Contract, shall release the Supplier from the obligation to provide deliveries or services, always provided, however, that the Supplier can demonstrate to the satisfaction of the Procuring Entity that it has completed all formalities in a timely manner, including applying for permits, authorizations and licenses necessary for the export of the products/goods, systems or services under the terms of the Contract. Termination of the Contract on this basis shall be for the Procuring Entity's convenience pursuant to Sub-Clause 35.3.

## **Section VIII. Special Conditions of Contract**

The following Special Conditions of Contract (SCC) shall supplement and / or amend the General Conditions of Contract (GCC). Whenever there is a conflict, the provisions herein shall prevail over those in the GCC.

GCC clause reference	Special Conditions	
<b>1.1(h)</b>	The Procuring Entity is:	<b>Maldives: Enhancing Employability Resilience of Youth Project Coordination Support Unit Ministry of Higher Education 2<sup>nd</sup> Floor, Fen Building Male', Maldives</b>
<b>1.1 (m)</b>	The Project Site(s)/Final Destination(s) is/are:	<b>Maldives Polytechnic, Male' Campus, Rehendhee Higon, Galolhu, 20364</b>
<b>4.2 (b)</b>	Interpretation	The version edition of Incoterms shall be <b>2010</b>
<b>5.1</b>	The language shall be:	<b>English</b>
<b>8.1</b>	For <b>notices</b> , the Procuring Entity's address shall be: Attention:  Street Address: Floor/ Room number: City: Post Code: Country: Telephone: Facsimile number: Electronic mail address:	<b>Waleeda Mohamed, Project Coordinator, Project Management Unit Ameenee Magu 2nd Floor, Fen Building Male' 20125 Maldives +960 3026975, 3026972 - <a href="mailto:waleeda.mohamed@mohe.gov.mv">waleeda.mohamed@mohe.gov.mv</a></b>
<b>9.1</b>	The governing law shall be:	<b>The law of the Republic of Maldives.</b>
<b>10.2</b>	The rules of procedure for arbitration proceedings pursuant to GCC Clause 10.2 shall be:	<b>Disputes shall be referred to adjudication or arbitration in accordance with the Arbitration Act of the Republic of Maldives.</b>
<b>13.1</b>	Details of Shipping and other	<b>For Goods supplied from abroad:</b>

**BIDDING DOCUMENT FOR THE PROCUREMENT OF POLYTECHNIC LABORATORY ITEM**

GCC clause reference	Special Conditions	
	documents to be furnished are:	<p>Upon shipment, the Supplier shall notify the Procuring Entity and the insurance company in writing the full details of the shipment. In the event of Goods sent by airfreight, the Supplier shall notify the Procuring Entity a minimum of forty-eight (48) hours ahead of dispatch, the name of the carrier, the flight number, the expected time of arrival, and the waybill number. The Supplier shall fax and then send by courier the following documents to the Procuring Entity, with a copy to the insurance company:</p> <ul style="list-style-type: none"> <li>(i) one originals and two copies of the Supplier’s invoice, showing the Procuring Entity as the consignee; the Contract number, Goods description, quantity, unit price, and total amount. Invoices must be signed in original;;</li> <li>(ii) one original and two copies of the negotiable, clean, on-board through bill of lading marked “freight prepaid” and showing Procuring Entity as the consignee and Notify Party as stated in the Contract, with delivery through to final destination as per the Schedule of Requirements and two copies of non-negotiable bill of lading, road consignment note, truck or air waybill, or multimodal transport document, marked “freight prepaid” and showing delivery through to final destination as per the Schedule of Requirements;</li> <li>(iii) two copies of the packing list identifying contents of each package;</li> <li>(iv) copy of the Insurance Certificate, showing the Procuring Entity as the beneficiary;</li> <li>(v) one original of the manufacturer’s or Supplier’s Warranty Certificate covering all items supplied;</li> <li>(vi) one original of the Supplier’s Certificate of Origin covering all items supplied;</li> <li>(vii) Goods Received Note duly signed by the authorized representative from the respective schools</li> </ul> <p><b>For Goods from within the Maldives:</b></p>

**BIDDING DOCUMENT FOR THE PROCUREMENT OF POLYTECHNIC LABORATORY ITEM**

GCC clause reference	Special Conditions	
		<p>Upon or before delivery of the Goods, the Supplier shall notify the Procuring Entity in writing and deliver the following documents to the Procuring Entity:</p> <ul style="list-style-type: none"> <li>(i) two originals and two copies of the Supplier’s invoice, showing the Procuring Entity, the Contract number, Goods’ description, quantity, unit price, and total amount. Invoices must be signed in original;</li> <li>(ii) two copies of delivery note, road consignment note, truck or air waybill, or multimodal transport document showing Procuring Entity as the consignee and delivery through to final destination as stated in the Contract;</li> <li>(iii) copy of the Insurance Certificate, showing the Procuring Entity as the beneficiary;</li> <li>(iv) four copies of the packing list identifying contents of each package;</li> <li>(v) one original of the manufacturer’s or Supplier’s Warranty certificate covering all items supplied;</li> <li>(vi) one original of the Supplier’s Certificate of Origin covering all items supplied;</li> </ul> <p>The above documents shall be received by the Procuring Entity before arrival of the Goods and, if not received, the Supplier will be responsible for any consequent expenses.</p>
15.1	Contract Price	The prices charged for the Goods supplied and the related Services performed shall not be adjustable.
16.1	Terms of payment	<p>GCC 16.1—The method and conditions of payment to be made to the Supplier under this Contract shall be as follows:</p> <p>Payment shall be made in Maldivian Rufiyaa in the following manner:</p> <ul style="list-style-type: none"> <li>(iii) <b>Arrival at Male’ Port:</b> Twenty (20) percent of the Contract Price shall be paid upon arrival of goods at a Male’ port and submission of copy of Bill of</li> </ul>

**BIDDING DOCUMENT FOR THE PROCUREMENT OF POLYTECHNIC  
LABORATORY ITEM**

GCC clause referenc e	Special Conditions	
		<p>Lading/Airway Bill and any other necessary document and invoice.</p> <p>(iv) <b>Delivery and Installation at the Final Destination:</b> The Sixty (60) percent of the Contract Price shall be paid to the Supplier after delivery and installation at the final destination, providing Goods Received Notes from Maldives Polytechnic, Male Campus</p> <p>(v) <b>Acceptance:</b> The Twenty (20) percent of the Contract Price shall be paid to the Supplier Upon final acceptance of the goods. <b>Maldives Polytechnic, Male Campus</b></p>
16.5	Payment delays	<p>The payment-delay period after which the Procuring Entity shall pay interest to the supplier shall be <b>35</b> days.</p> <p>The interest rate that shall be applied is <b>2 %</b> per Annum</p>
17.1	Taxes and Duties	<p><b>The Supplier shall be entirely responsible for all taxes, stamp duties, license fees and other such levies imposed.</b></p>
18.1	Performance Security	<p><b>A Performance Security shall be required at 10% of the contract price.</b></p>
18.3	<p>If required, the Performance Security shall be in the form of:</p> <p>If required, the Performance security shall be denominated in</p>	<p><b>Bank Guarantee</b></p> <p><b>Maldivian Rufiyaa (MVR)</b></p>
18.4	Discharge of the Performance Security shall take place:	<p><b>After all the goods are delivered to the final destinations and Acceptance Letter of Goods is issued by the Coordination Support Unit.</b></p>
23.2	The packing, marking and documentation within and outside the packages shall be:	<p><b>Maldives: Enhancing Employability Resilience of Youth Project (MEERY) Ministry of Higher Education Maldives Polytechnic, Male' Rehendhee Higun, Galolhu, 20364</b></p>
24.1	The insurance coverage shall be:	<p><b>As specified in the Incoterms.</b></p>

**BIDDING DOCUMENT FOR THE PROCUREMENT OF POLYTECHNIC LABORATORY ITEM**

GCC clause reference	Special Conditions	
25.1	Responsibility for transportation of the Goods shall be:	<b>The Supplier is required under the Contract to transport the Goods to a specified place of final destination within the Purchaser's country, defined as Polytechnic, transport to such place of destination in the Purchaser's country, including insurance and storage, as shall be specified in the Contract, shall be arranged by the Supplier, and related costs shall be included in the Contract Price.</b>
27.1	The liquidated damage shall be:	<b>Contract Price*0.005*Late Duration (Days)</b>
27.1	The maximum amount of liquidated damages shall be:	<b>10% of contract price</b>
28.3	The period of the Warranty shall be:  For purposes of the Warranty, the place(s) of final destination(s) shall be:	<b>18 Months Parts and Service Warranty</b>
28.5	The period for repair or replacement shall be:	<b>35 Days.</b>



## **Section IX. Contract Forms**

### **Table of Forms**

1. Contract Agreement .....	90
2. Performance Security .....	92

## **1. Contract Agreement**

### **Procurement Reference:**

THIS CONTRACT AGREEMENT is made

the *[insert: number]* day of *[insert: month]*, *[insert: year]*.

BETWEEN

- (1) *[insert complete name of Procuring Entity]*, a *[insert description of type of legal entity, for example, an agency of the Ministry of .... of the Government of the Republic of Maldives, or corporation incorporated under the laws of Republic of Maldives]* and having its principal place of business at *[insert address of Procuring Entity]* (hereinafter called “the Procuring Entity”), and
- (2) *[insert name of Supplier]*, a corporation incorporated under the laws of *[insert: country of Supplier]* and having its principal place of business at *[insert: address of Supplier]* (hereinafter called “the Supplier”).

WHEREAS the Procuring Entity invited bids for certain Goods and ancillary services, viz., *[insert brief description of Goods and Services]* and has accepted a Bid by the Supplier for the supply of those Goods and Services in the sum of *[insert Contract Price in words and figures, expressed in the Contract currency(ies)]* (hereinafter called “the Contract Price”).

NOW THIS AGREEMENT WITNESSETH AS FOLLOWS:

1. In this Agreement words and expressions shall have the same meanings as are respectively assigned to them in the Conditions of Contract referred to.
2. The following documents shall constitute the Contract between the Procuring Entity and the Supplier, and each shall be read and construed as an integral part of the Contract:
  - (a) This Contract Agreement;
  - (b) Special Conditions of Contract;
  - (c) General Conditions of Contract;
  - (d) Technical Requirements (including Schedule of Requirements and Technical Specifications);
  - (e) The Supplier’s Bid and original Price Schedules;
  - (f) The Procuring Entity’s Letter of Acceptance;
  - (g) The Bidding Document.
3. This Contract shall prevail over all other Contract documents. In the event of any discrepancy or inconsistency within the Contract documents, then the documents shall prevail in the order listed above.

**BIDDING DOCUMENT FOR THE PROCUREMENT OF POLYTECHNIC LABORATORY ITEM**

4. In consideration of the payments to be made by the Procuring Entity to the Supplier as hereinafter mentioned, the Supplier hereby covenants with the Procuring Entity to provide the Goods and Services and to remedy defects therein in conformity in all respects with the provisions of the Contract.
5. The Procuring Entity hereby covenants to pay the Supplier in consideration of the provision of the Goods and Services and the remedying of defects therein, the Contract Price or such other sum as may become payable under the provisions of the Contract at the times and in the manner prescribed by the Contract.

IN WITNESS whereof the parties hereto have caused this Agreement to be executed in accordance with the laws of Republic of Maldives on the day, month and year indicated above.

**For and on behalf of the Procuring Entity**

Signed: .....
Name:
In the capacity of: <i>[Title or other appropriate designation]</i>

**For and on behalf of the Supplier**

Signed: ..... <i>[signature of authorized representative(s) of the Supplier]</i>
Name:
In the capacity of: <i>[Title or other appropriate designation]</i>

## **2. Performance Security**

*[The issuing bank, as requested by the successful Bidder, shall fill in this form in accordance with the instructions indicated]*

Date: *[insert date (as day, month, and year)]*  
Title of the procurement: *[Insert general title of the procurement]*  
Procurement Reference No: *[insert reference]*

Bank's Branch or Office: *[insert complete name of Guarantor]*

**Beneficiary:** *[insert complete name of Procuring Entity]*

**PERFORMANCE GUARANTEE No.:** *[insert Performance Guarantee number]*

We have been informed that *[insert complete name of Supplier]* (hereinafter called "the Supplier") has entered into Contract No. *[insert number]* dated *[insert day and month]*, *[insert year]* with you, for the supply of *[description of Goods and related Services]* (hereinafter called "the Contract").

Furthermore, we understand that, according to the conditions of the Contract, a Performance Guarantee is required.

At the request of the Supplier, we hereby irrevocably undertake to pay you any sum(s) not exceeding *[insert amount(s)<sup>1</sup> in figures and words]* upon receipt by us of your first demand in writing declaring the Supplier to be in default under the Contract, without cavil or argument, or your needing to prove or to show grounds or reasons for your demand or the sum specified therein.

This Guarantee shall expire no later than the *[insert number]* day of *[insert month]* *[insert year]*,<sup>2</sup> and any demand for payment under it must be received by us at this office on or before that date. We agree to a one-time extension of this Guarantee for a period not to exceed *[six months]* *[one year]*, in response to the Procuring Entity's written request for such extension, such request to be presented to us before the expiry of the Guarantee.

This guarantee is subject to the Uniform Rules for Demand Guarantees, ICC Publication No. 458, except that subparagraph (ii) of Sub-article 20(a) is hereby excluded.

.....  
*[signatures of authorized representatives of the bank]*

---

<sup>1</sup> The Bank shall insert the amount(s) specified in the SCC and denominated, as specified in the SCC, either in the currency(ies) of the Contract or a freely convertible currency acceptable to the Procuring Entity.

<sup>2</sup> Dates established in accordance with Clause 18.4 of the General Conditions of Contract ("GCC"), taking into account any warranty obligations of the Supplier under Clause 16.2 of the GCC intended to be secured by a partial Performance Guarantee.