

PAVING PLAN (OPTION 2)
 SCALE 1:200
 0m 5m

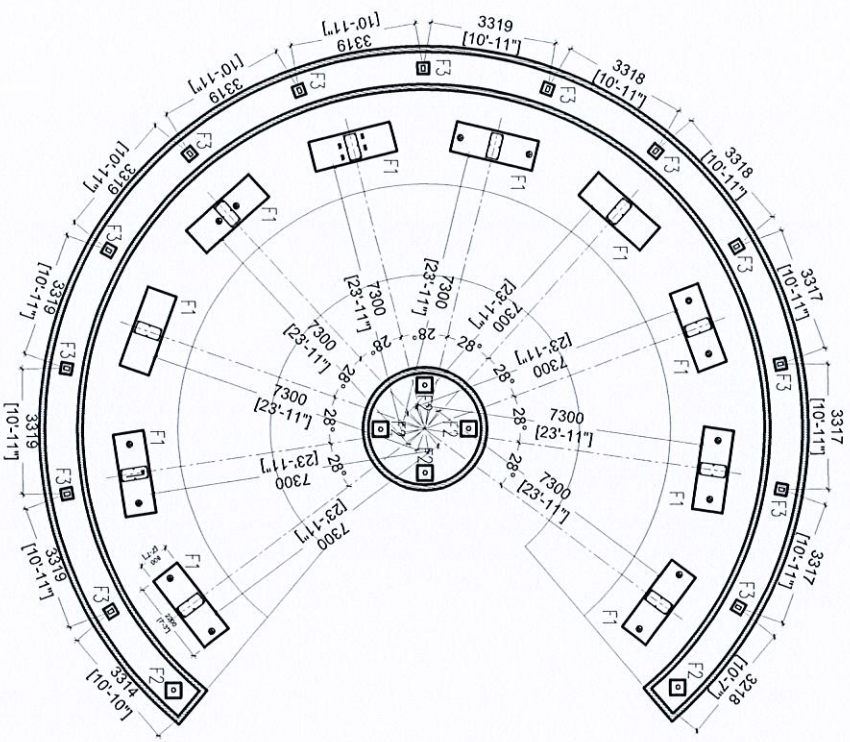

TOTAL AREA= 422.95 m²
 GRAY PAVING AREA= 44.04 m²
 RED PAVING AREA= 95.47 m²
 GREEN PAVING AREA= 62.05 m²
 OUTER PLANTER BOX AREA= 51.35 m²
 CENTER PLANTER BOX AREA= 8.07 m²



FOOTING PLAN
SCALE 1:200
0m 5m



NOTE:
F1 - 2200X800X250 - T10@200/c BW BOT
ALL THE BEAMS ARE OF TYPE TB

ANNEX 1 -

A. Proposed Equipment with Technical Drawings

1. PD 1650 – Double Leg Press Trainer

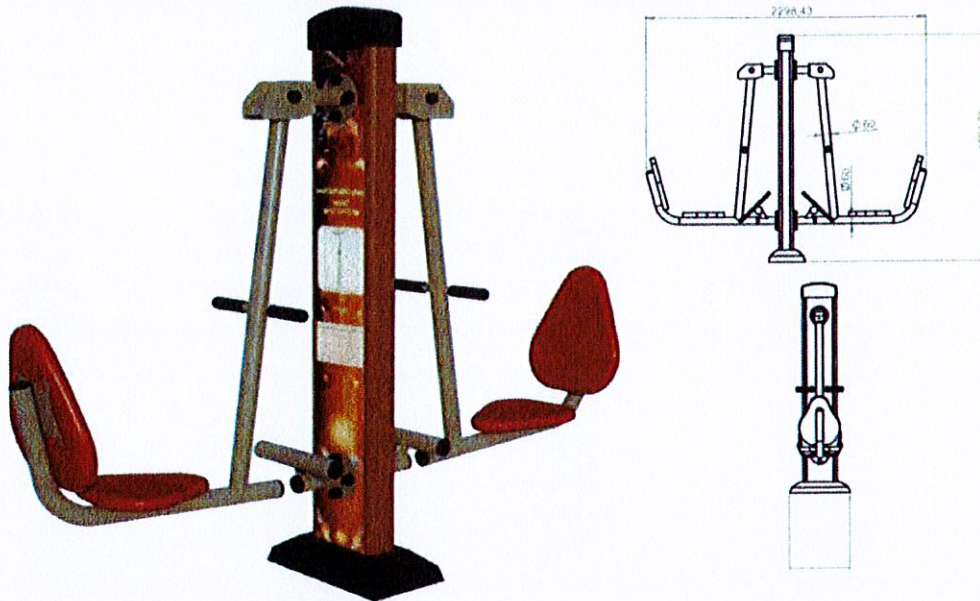

2. PD 1652 – Double Seated Pull-Down Trainer

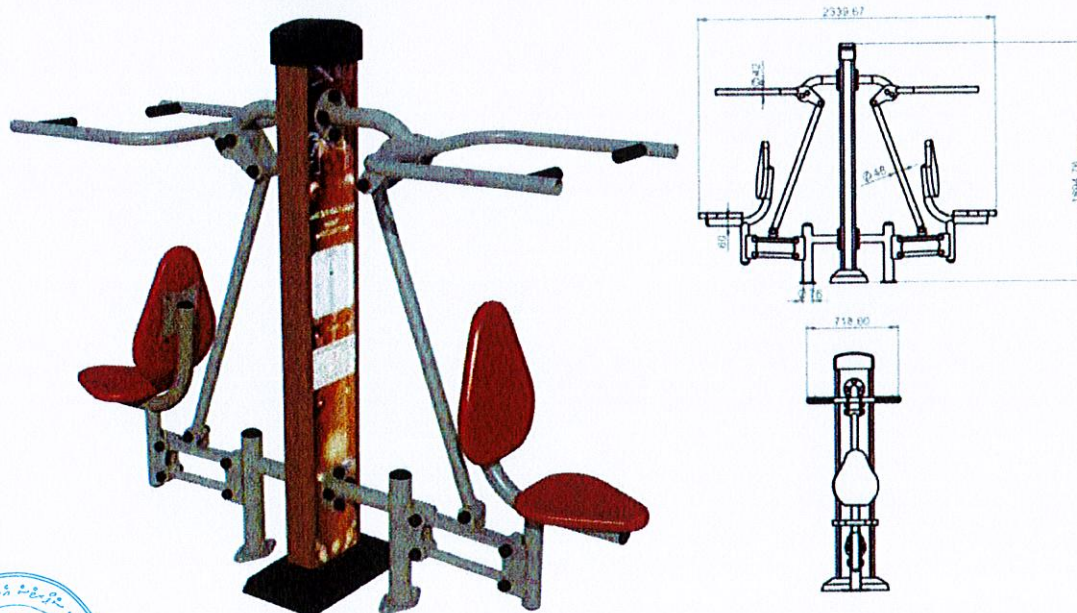

3. PD 1654 – Double Bike

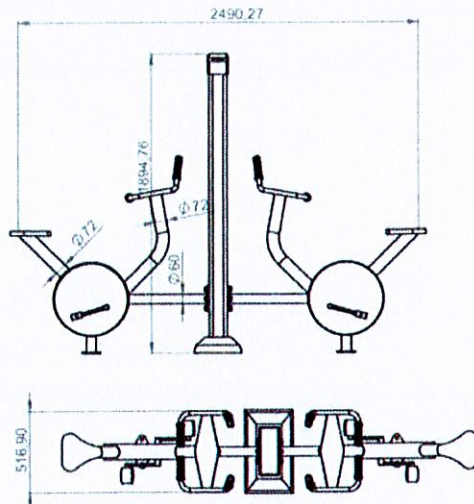
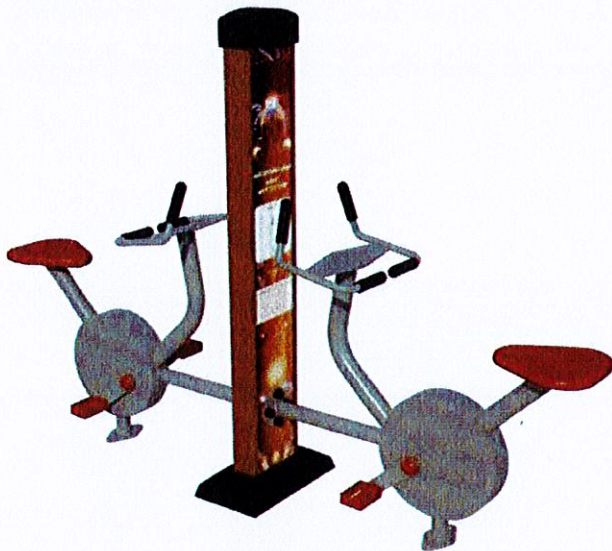

4. PD 1656 – Double Tai-Chi Spinner

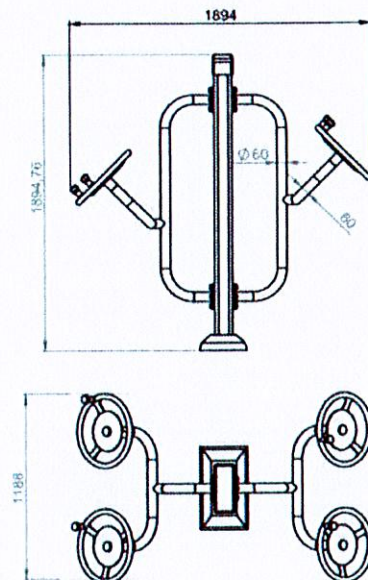
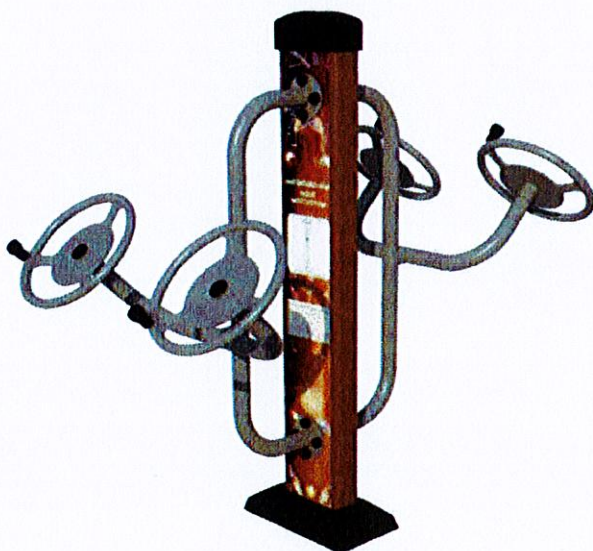

5. PD 1658 – Double Riding Trainer x 2

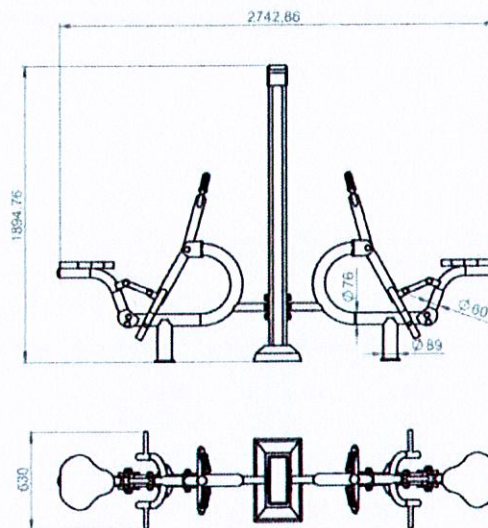

6. PD 1666 – Double Elliptical Trainer x 2

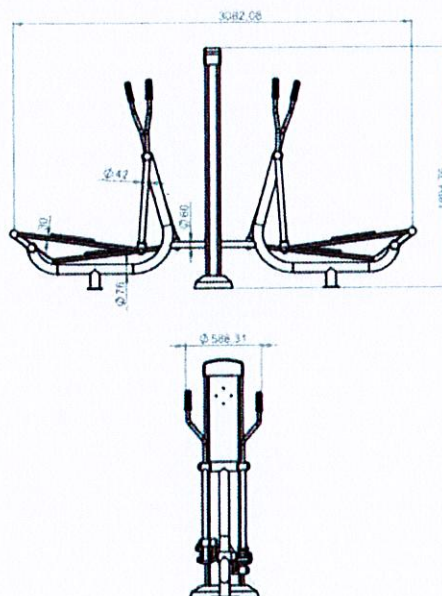

7. PD 1670 – Double Sit-up Bench

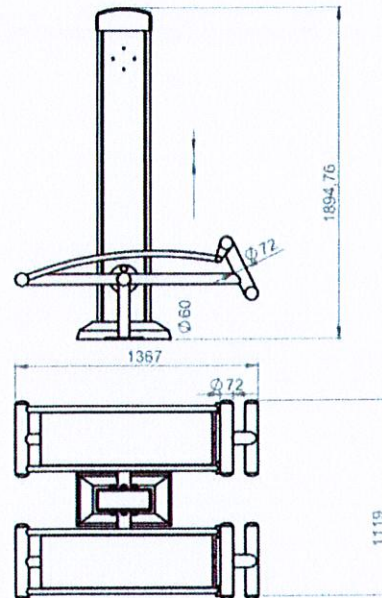

8. PD 1672 – Double Air-Walker

