

އިތުރު
ފަންދު

BML/PD/OPN-BID/2022/036

އިންޓަނެޓް ރިސާޔާ ބަންދު

ބަންދު ހުށަހަޅާނީ ފަންދު ހުށަހަޅާނީ ދަންނަވާ ބަންދު ހުށަހަޅާނީ ފަންދު ހުށަހަޅާނީ ފަންދު ހުށަހަޅާނީ ފަންދު ހުށަހަޅާނީ

ބަންދު ހުށަހަޅާނީ

މި ފަންދު ހުށަހަޅާނީ ފަންދު ހުށަހަޅާނީ ފަންދު ހުށަހަޅާނީ ފަންދު ހުށަހަޅާނީ ފަންދު ހުށަހަޅާނީ ފަންދު ހުށަހަޅާނީ

ބަންދު ހުށަހަޅާނީ www.bankofmaldives.com.mv/news-and-media ގައި ބަންދު ހުށަހަޅާނީ ފަންދު ހުށަހަޅާނީ ފަންދު ހުށަހަޅާނީ ފަންދު ހުށަހަޅާނީ ފަންދު ހުށަހަޅާނީ

ފަންދު ހުށަހަޅާނީ ފަންދު ހުށަހަޅާނީ ފަންދު ހުށަހަޅާނީ ފަންދު ހުށަހަޅާނީ ފަންދު ހުށަހަޅާނީ ފަންދު ހުށަހަޅާނީ

ފަންދު ހުށަހަޅާނީ ފަންދު ހުށަހަޅާނީ ފަންދު ހުށަހަޅާނީ ފަންދު ހުށަހަޅާނީ ފަންދު ހުށަހަޅާނީ ފަންދު ހުށަހަޅާނީ

ފަންދު / ބަންދު	ފަންދު	ފަންދު	ފަންދު
ފަންދު ހުށަހަޅާނީ ފަންދު ހުށަހަޅާނީ ފަންދު ހުށަހަޅާނީ ފަންދު ހުށަހަޅާނީ ފަންދު ހުށަހަޅާނީ	ފަންދު ހުށަހަޅާނީ 02:00	2022 ބަންދު 5 (އަންނަދު)	ފަންދު ހުށަހަޅާނީ
ފަންދު ހުށަހަޅާނީ ފަންދު ހުށަހަޅާނީ ފަންދު ހުށަހަޅާނީ ފަންދު ހުށަހަޅާނީ ފަންދު ހުށަހަޅާނީ	ފަންދު ހުށަހަޅާނީ 02:00	2022 ބަންދު 15 (އަންނަދު)	ފަންދު ހުށަހަޅާނީ (ފަންދު ހުށަހަޅާނީ)
		• ފަންދު ހުށަހަޅާނީ - openbidding@bml.com.mv 3015349	ފަންދު ހުށަހަޅާނީ ފަންދު ހުށަހަޅާނީ:

28 ސަފަލު 1443
29 ބަންދު 2022

Instruction to Bidders

This document includes information relevant to the procurement of goods and services, bidding procedure for bidders and guidelines to prepare the bids.

A. Introduction	
Scope of Bid	Bank of Maldives PLC invites sealed bids from eligible bidders for Hulhumale Branch Renovation Works. A local competitive bidding will be conducted in accordance with Bank of Maldives PLC's bidding procedure and is open to all Bidders.
Procurement Reference and Name	BML/PD/OPN-BID/2022/036 Hulhumale Branch Renovation Works
Eligible Bidders	This invitation is open to all interested with a formal intent to enter into an agreement. Each Bidder shall submit only one bid. A bidder who submits or participates in more than one bid will cause all the bid proposals for that particular procurement to be disqualified.
B. Preparation of Bids	
Language	The language of the Bid is: English or Dhivehi
Documents Comprising the Bid	The Bidder shall submit the following completed documents with its Bid: Form 1 – Schedule of Requirement (not applicable) Form 2A – Bidder Information Sheet Form 2B – Bid Submission Form Form 2C - Price Schedule for Goods & Services
Bid Prices and Currency	The Bidders shall quote the items to be procured individually specifying the unit rates and prices in <i>Maldivian Rufiyaa</i> . Including GST at the time of current rate
Bid Validity	The bid shall remain valid for 30 days from the date of opening the bids.
D. Submission and Opening of Bids	
Bid Submission	Bidders shall submit their bids on the date of submission at the specified location and time indicated in this section.
Acceptance of Bids	BML shall not accept bids before or after the specified closing time.

Location, date and Time	<p>For bid submission Bank of Maldives, Head Office, 5th Floor, Procurement Meeting Room Island: Male' The deadline for bid submission: Date: 15th June 2022 Time: 02:00pm (Maldivian Standard Time)</p>
Contact details for further information	<p>Please contact; Procurement Department, Telephone: 3015359, 3015349 Email address: openbidding@bml.com.mv</p>
Bid Opening	<p>BML shall conduct the bid opening on the Date of Bid Submission. BML shall open the bids publicly immediately after the expiry of the limit for submission of the bids indicated in the tender documents.</p>
E. Evaluation, and Comparison of Bids	
Confidentiality	<p>Information relating to the examination, evaluation and comparison of Bids, and recommendation of contract award, shall not be disclosed to Bidders or any other persons not officially concerned with such process until the award to the successful bidder is notified.</p>
Documents Establishing the Qualifications of the Bidder	<p>BML shall evaluate each Bid based on the evaluation criterion and methodologies specified in Evaluation and Qualification Criteria to determine the most acceptable bid. No other criteria or methodology will be permitted.</p>
F. Award of Contract	
Award Criteria	<p>BML shall award the Contract to the Bidder whose offer has been determined to be the most acceptable Bid and shall notify the successful Bidder, in writing, that its Bid has been accepted.</p>
G. Appeals and complaints	
Regarding conduct of a bid	<p>Bidders are allowed to file appeals and complaints regarding conduct of a bid, in writing, within 7 (seven) days of opening of the bid.</p>
Regarding outcome of a bid (an award or decision to award)	<p>Bidders are allowed to file appeals and complaints regarding outcome of a bid (an award or decision to award), in writing, within 7 (seven) days of awarding the contract.</p>

Evaluation and Qualification Criteria

Table of Criteria

Evaluation Criteria

Evaluation Criteria	Weightage
Price	80%
Delivery	20% (duration)

Eligibility criteria

1 reference letter above MVR 200,000.00 similar nature of work

Note:-

- Bids will be opened in the presence of the bidders and/or representatives of the bidders.
- Representatives from companies submitting proposals must submit a board resolution on company's behalf.
- Fine for late delivery will be charged per day and if the work/ item(s) are not completed within the agreed period, Bank has the right to cancel the contract.
- Penalty charge shall be imposed in respect of each item/service of non-compliance with the bid conditions.
- (If applicable) it shall remain your responsibility to ensure that your quotation/proposal reach us on or before the deadline. Quotations/Proposals that are received after the deadline indicated above, for whatever reasons, shall not be considered for evaluation.
- Please note that we may purchase all the items, selected items, or none of the items, based on comparative offers from different vendors.
- Please note that we may award the work, based on comparative offers from different vendors and Bank has the right to check the vendor background and performance on previous projects before awarding.
- Any actual or prospective bidder or contractor who is aggrieved in connection with the solicitation or award of a bid, contract or proposal, may appeal to the MD & CEO of BML. The appeal must be in writing and must list the pertinent facts giving rise to the appeal.

Form 1 - Schedule of Requirement

(Not Applicable)

Form 1 A

List of Goods and Related Services

Lot No. : [if applicable]				
Lot Name : [if applicable]				
Item No.	Name of Goods or Related Services	Description	Unit of Measurement	Quantity

Lot No. : [if applicable]				
Lot Name : [if applicable]				
Item No.	Name of Goods or Related Services	Description	Unit of Measurement	Quantity

Lot No. : [if applicable]				
Lot Name : [if applicable]				
Item No.	Name of Goods or Related Services	Description	Unit of Measurement	Quantity

Form 1 B

Delivery and Completion Schedule

The date or period for delivery to be specified below;

Item No.	Description of Goods or Related Services	Date or Period for Delivery	Location	Required Arrival Date of Goods or Completion Date for Related Services
1.	Hulhumale Branch Renovation Works			

Form 1 C Specifications

Information sheet attached with the announcement

Form 2 – Bidding Forms

Table of Forms

A- Bidders Information Form.

B- Bid Submission Form.

C- Price Schedule for Goods and Services.

Form 2A

Bidder Information Sheet

Date: _____

Invitation for Bid No.: *BML/PD/OPN-BID/2022/036*

Legal Name of Bidder	
Bidder's Authorised Representative Information	Name: Address: Telephone/Fax Numbers: Email Address:
List of bid documents to be submitted: as per vendor registration application form. <u>In case of new vendors</u> , it is requested to apply for registration as vendor with all related documents. Any changes/update to the information provided in the registration form, shall be submitted to Bank of Maldives along with revised documents.	



Form 2B

Bid Submission Form

Date: _____

Invitation for Bid No.: *BML/PD/OPN-BID/2022/036*

To: BANK OF MALDIVES PLC.

I/We, the undersigned, declare that:

- (a) I/We offer to supply in conformity with the Bidding Document and in accordance with the delivery schedule specified in the Schedule of Supply, the following Goods and Related Services: _____
_____;
- (b) The total price of my/our Bid, is: _____
_____;
- (c) My/Our Bid shall be valid for a period of 30 days from the date of bid opening in accordance with the Bidding Document, and it shall remain binding upon me/us and may be accepted at any time before the expiration of that period;
- (d) I/We are not participating, as Bidders, in more than one Bid in this bidding process, other than alternative offers in accordance with the Bidding Document;
- (e) I/We understand that this Bid, together with your written acceptance thereof included in your notification of award shall constitute a binding contract between us,
- (f) I/We declare that all the information provided in connection with this bid is true and all documents are true copies of genuine and valid originals.
- (g) I/We confirm that I/we (including owners/ beneficial owners and/or shareholders / partners of the bidder) have not in any way been associated, in the preparation of this Bid, with an employee of Bank of Maldives PLC.
- (h) I/We confirm that I/we (including owners/ beneficial owners and/or shareholders / partners of the bidder) are not employee(s) or immediate family member(s) of employee(s) or Board of Director(s) of Bank of Maldives PLC (Immediate family members are defined as children, spouses and parents).
- (i) I/We confirm that I/we have carefully read, understood and agree to all the terms and conditions of the Bidding Documents.
- (j) I/We understand that you are not bound to accept the lowest or any Bid you may receive.

Name _____

In the capacity of _____

Signed _____

Duly authorized to sign the Bid for and on behalf of _____

Office / Company Seal (if applicable) _____

Date _____

If a bid is awarded on the basis of false information provided, the Bank has the right to disqualify the bidder. In review of this, Bank will be considering the past performance of the bidder in future bids of this nature.

Form 2C

Price Schedule of Service

Name of Bidder _____

Procurement Reference and Name _____

TIN no: _____

#	Description	Total price (MVR) (including 6% GST price)	Duration
1.	Hulhumale Branch Renovation Works		
Grand Total Price			

Note

- Please submit a quotation/proposal/BOQ with the detail specification given in the information sheet.
- In addition, please include following details in the quotation/proposal:
 - Detail specification of the quoted product
 - Breakdown of the price (if applicable)
 - Price inclusive of all taxes applicable
 - Local vendors should quote price in MVR
 - Delivery duration in calendar days (if not fixed in the request)
 - Payment Terms
 - Quotation validity period
- Proposal with multiple options (other than specified above) **WILL NOT** be accepted.
- Days will be counted starting from the date issuing the Purchase order/Site handover.
- Fine for late delivery/completion will be charged per day and if the work/ item(s) are not completed within the agreed period, Bank has the right to cancel the contract.
- No advance payment.

**HULHUMALE BRANCH RENOVATION WORKS
2022
BID DOCUMENT**



Properties development Department

Properties development Unit

April 2022

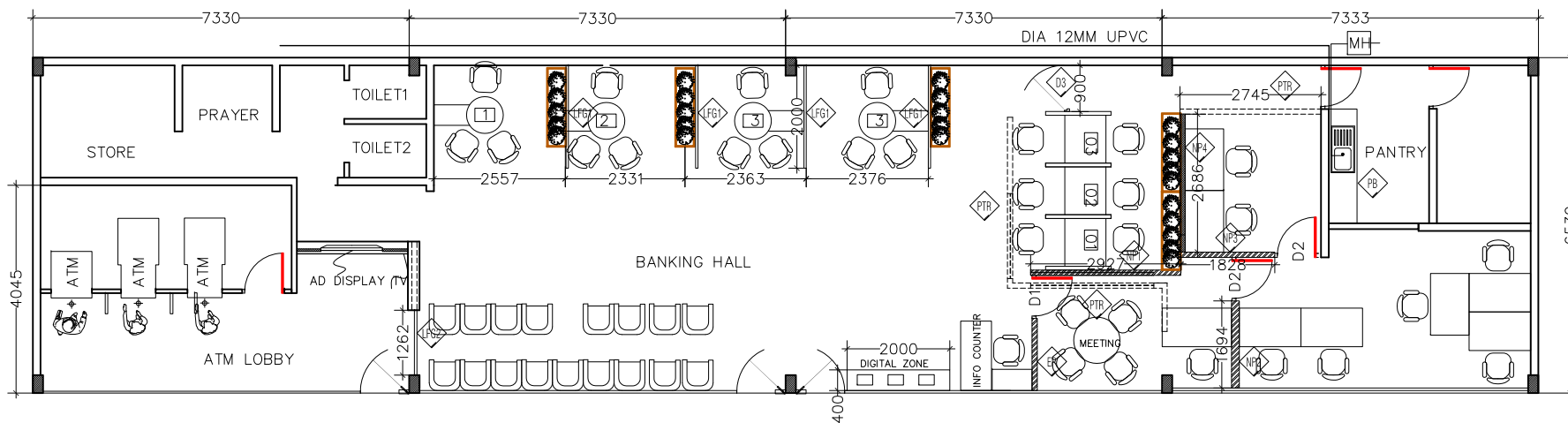

GROUND FLOOR PLAN
SCALE: 1:100

- ◊ FP EXISTING PARTITION
- ◊ PTR PARTITION TO BE REMOVED
- ◊ NP NEW PARTITION
- ◊ LFG LAMINATED FIXED GLASS WITH FRAME

PROJECT :

BML HULHUMALE BRANCH

TITLE :

FLOOR PLAN

CLIENT :

BML PLC

DESIGN BY	MY	
DRAWN BY	MY	
CHECKED		
DATE	FEB 2022	DWG No
SCALE	1:130	A-01/4
PROJECT No		

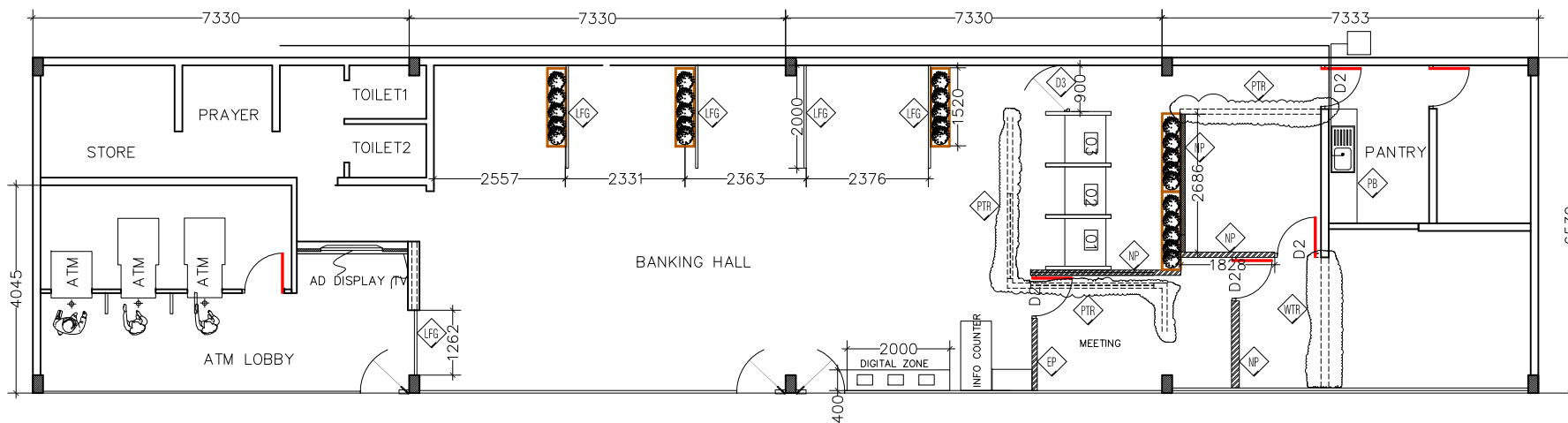

GROUND FLOOR PLAN
SCALE: 1:100

- EP EXISTING PARTITION
- PTR PARTITION TO BE REMOVED
- WTR WALL TO BE REMOVED
- NP NEW PARTITION
- LFG LAMINATED FIXED GLASS WITH FRAME

PROJECT :

BML HULHUMALE BRANCH

TITLE :

FLOOR PLAN

CLIENT :

BML PLC

DESIGN BY	MY	
DRAWN BY	MY	
CHECKED		
DATE	FEB 2022	DWG No
SCALE	1:130	A-02/4
PROJECT No		

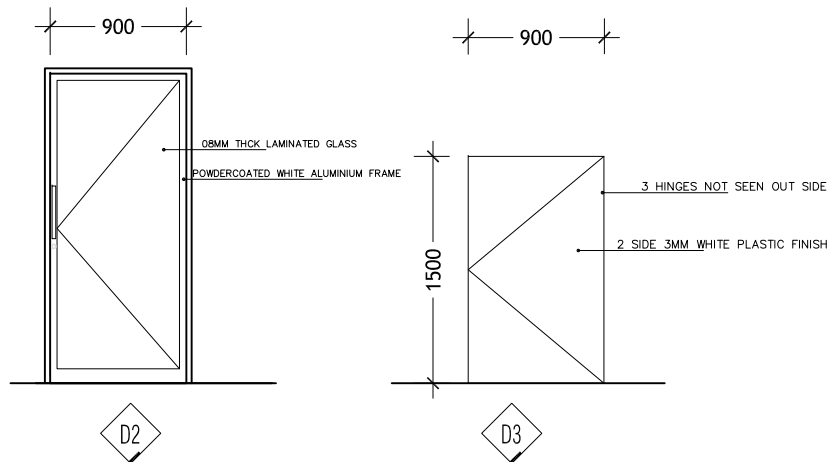

PANEL	CLEAR LAMINATED GLASS 8MM	HOLLOW CORE 4MM PLYWOOD BOTH SIDE
FINISH	POWDER COATED WHITE ALUMINIUM	BOTH SIDE 3MM RED PLASTIC FINISH
HINGES	4" X4 SS BARING HINGES	4" X2 SS BARING HINGES NOT SEEN OUT SIDE
LOCKS	DOOR LOCK WITH HANDLE	PUSH PULL LOCK
HANDLES	STAINLESS STEEL	PULL KNOB INSIDE
DOOR CLOSER	STAINLESS STEEL	
DOOR STOPPER	FLOOR MOUNT	FLOOR MOUNT

PROJECT :

**BML HULHUMALE
BRANCH RENOVATION**

TITLE :

DOORS

CLIENT :

BML PLC

DESIGN BY	MY	
DRAWN BY	MY	
CHECKED		
DATE	MAY 2015	DWG No
SCALE	1:50	A-03/4
PROJECT No		

DIGITAL BANKING STAND DETAIL
 SCALE 1:15

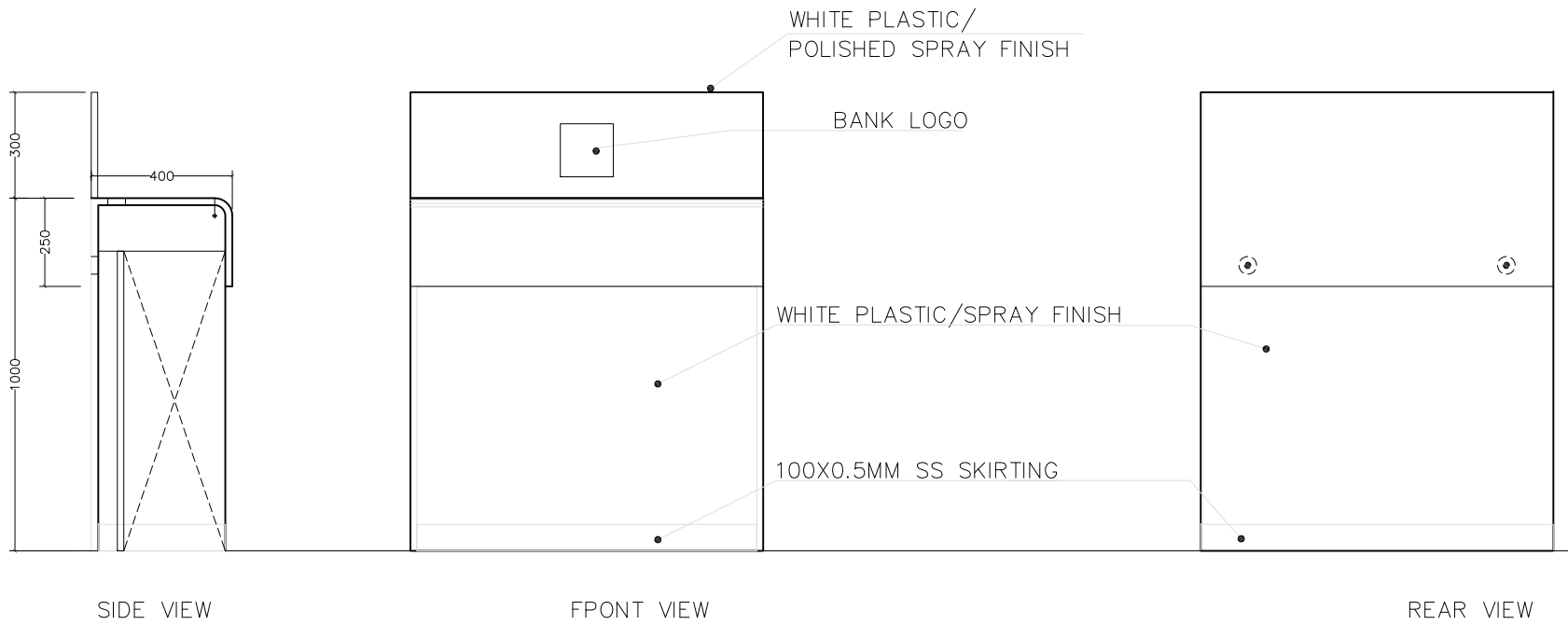
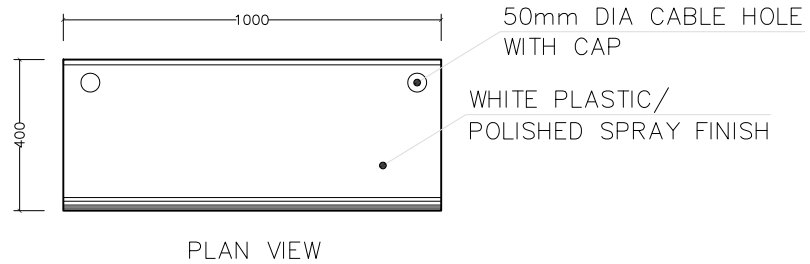

PROJECT :

BML HULHUMALE
 BRANCH RENOV

TITLE :

DIGITAL ZONE STAND

CLIENT :

BML PLC

DESIGN BY MY

DRAWN BY MY

CHECKED

DATE MAR 2022 DWG No

SCALE 1:20

PROJECT No A 4/4

<i>Item</i>	<i>Description</i>	<i>Unit</i>	<i>Qty</i>	<i>Rate</i>	<i>Total</i>
<u>HULHUMALE BRANCH RENOATION WORKS 2022</u>					
1.1	PIPE WORK WITHIN THE BUILDING				
(1)	<u>Water supply</u> (a) Provide and fix UPVC high pressure pipes to provide fresh water to all Muslim showers, flushing tanks of water closets, taps and to kitchen sink. Price shall include for necessary piping, connections, excavations (if required) and other accessories as per drawings				
(2)	<u>Disposal system</u> (a) Provide and fix UPVC pipes for waste disposal from new pantry wastes. Price shall include for necessary piping, connections, and other accessories as per drawings (b) Provide and fix UPVC pipes for sewage disposal from water closet including floor clean outs. Price shall include for necessary piping, connections, and other accessories as per drawings (c) Provide and fix waste disposal manhole for waste disposal from new Pantry. Price shall include for necessary piping, connections, channel making inside the manhole and other accessories as required				
1.2	PIPE WORK WITHIN THE BUILDING				
(2)	Complete construction of water supply pipework including all pipework, fittings, valves, etc. and connect to existing fresh water line.	LS	1.00		
(2)	Complete construction of discharge pipework including all pipework, vent pipework, vent cover, fittings, valves, inspection chambers etc. to existing pipelines	LS	1.00		
1.2	<u>TOILET UPGRADING WORKS</u>				
1.2.1	<u>FIXTURES</u>				
(1)	Provide and fix standard wash basins (medium quality) with bottle trap and drain including water supply and dispose pipe connection	no	2.00		
(2)	Provide and fix wash basin tap with valves	no	2.00		
(3)	Provide and fix water closet including stop valves, flushing cistern and all necessary accessories	no	2.00		
(4)	Tissue Paper holder	no	2.00		
(5)	Towel rail	no	2.00		
(6)	Mirror set with mirror light	no	2.00		
(7)	Provide and fix Muslim shower with tap	no	2.00		
(8)	Provide and fix floor trap	no	2.00		
(9)	Provide and fix kitchen sink	no	1.00		
(10)	Provide and fix kitchen sink tap	no	1.00		
(11)	Make ablution area and install 1 taps	LS	1.00		
(12)	provide and install toilet wall cabinet 600X900X250	LS	2.00		

Item	Description	Unit	Qty	Rate	Total
1.3	NEW PANTRY AREA				
(1)	-Make ready of Pantry wall and cover the DB to receive tiles	m ²	3.30		
(2)	provide and installing granite vanity top 600X 2200)mm in the pantry area with SS sink including wasting plug , water and drain connection SS kitchen water tap	No	1.00		
(3)	provide and install kitchen bottom cabinet with soft close railing for drawers and cabinet doors 550X2200X800 with bottom base including SS skirting white Formica finish	No	1.00		
(4)	provide and install kitchen top cabinet 300X2200X800 fixed to the wall with white Formica finish	No	1.00		
(5)	Tiling on back splash on pantry area wall 1.5m height from the ground level, clear white wall tiles or other recommended materials to be used	m ²	3.30		
1.4	REMOVING EXISTING COUNTERS				
(1)	Remove existing counters without damage and repair to re-use is and transport where bank directed (Male/Hulhumale)	No	7.00		
1.5	REPAINTING OF EXISTING TABLES				
(1)	Repair and spray painting of existing workstations and install is in the Branch	No	4.00		
1.6	REMOVING OF EXISTING PARTITIONS				
(1)	Removing of existing partitions and sliding door marked in the drawing (glass door to be transported to the location where BML directed.)	sum	1.00		
1.7	PARTITION AND GLASS WORKS				
a	FGP - Full height Glass partition (10mm Laminated Glass) partition outer frame only - material used for framing and 9mm plywood on both side with 3mm opaque white plastic finish				
1.7.1	LFG 1 -	m ²	22.72		
1.7.2	LFG 2 -	m ²	3.25		
1.7.3	NP1 (2.9MX2.6M)	m ²	7.54		
1.7.4	NP2 (1.7MX2.6M)	m ²	4.42		
1.7.5	NP3 (1.9MX2.6M)	m ²	4.68		
1.7.6	NP4 (2.68X2.6M)	m ²	6.96		
1.7.6	D1 900X2050mm existing Door				
1.7.7	D2 900X2050mm white aluminum frame with 6mm laminated glass fixing with SS hinges, locks, door closer & doorstopper	No	3.00		
1.7.8	D3 900X1.5mm white plastic finish both side with SS baring hinges, locks & doorstopper	No	1.00		
2.0	FABRICATION OF DIGITAL ZONE				
(1)	Fabrication of digital zone Bench as per the drawing	No	2.00		
3.0	OTHER WORKS				
(1)	removing of existing pantry bench and pantry cabinets with wall tiles and making good to receive paint	LS	1.00		
(2)	painting all walls inside and outside of the Branch where applicable	LS	1.00		
HULHUMALE BRANCH RENOVATION WORKS 2022					
TOTAL OF BILL No: 01 -					
				GST 6%	
TOTAL OF HLML BRANCH RENOV					

