



**Ministry of Education
Republic of Maldives**

Supply, delivery and installation classroom furniture and white boards to Muhyiddin School, K. Villingili (EEDP/G.22)

Announcement No: (IUL) 22-E/1/2018/35

INFORMATION FOR BIDDERS

The Ministry of Education now invites sealed quotations from eligible bidders for the following items:

Furniture for Muhyiddin School:

- 420 Student Desk
- 12 Teacher Table
- 12 White Boards
- 420 Student Chairs (Plastic, No armrest)
- 12 Teacher Chair (With armrest)

EVALUATION CRITERIA:

- The evaluation criteria is as follows:

PHASE 1:

| Details | Points |
|---|---------------|
| Warranty 12 Months – Compulsory for all bidders | Compulsory |
| Price | 50 |
| Duration | 30 |
| RFQ document submitted (Section B and Section C completed) | 5 |
| Company Profile: <ul style="list-style-type: none"> • <u>Company Profile: (4 Points Total)</u> *Company Registration *GST Registration *Short Company Profile • <u>Financials: (5 Points Total)</u> *Bank Statement dated no earlier than 30 days prior to quotation submission date – 5 marks • <u>Experience (Maximum 3): 6 Points Total</u> *Supplied school furniture similar to requirement in past 3 years (Maximum 3) - 2 Points each *Other projects of related nature to requirement in the last 3 years (Maximum 3) – 1 Point each | 15 |

PHASE 2:

This phase is only for the bidder with the highest points from PHASE 1. In the event if the selected bidder fails, the second bidder with the highest points will be selected and so on.

| Details | Points |
|--|---------------|
| Technical Evaluation (Specifications and Sample) | Pass/Fail |

The vendors must provide a sample of the furniture for evaluation purposes (PHASE 2). The Coordination Support Unit will request for viewing the sample within 5 days of informing the selected bidder.

Important Information to be noted:

- Kindly adhere to all terms given in Section A and Section B of the RFQ document.
- Please make sure to complete and submit Section B and C. The quote will not be accepted without these two sections.
- Please be informed that the furniture is to be of regular standard specification and models for school classrooms. The furniture must be of excellent quality and brand new.
- Please provide clear specifications in a separate quotation in accordance with the detailed specs. All prices are to be **DDP**.
- Quotation submission is on 15th February 2018, Thursday at 13:00pm in Coordination Support Unit (Ground Floor, Ghaazee Building).

8th February 2018



1. Total height = 795mm to 805mm
2. Width = 440mm to 455mm
3. Seating height = 420mm to 435mm
4. Seating width = 380mm to 390mm

| MEMBER CODE (ALPHABETS) |
|-------------------------|
| A (table top) |
| B (Apron rail) |
| C (Apron rail) |
| D (Apron rail) |
| Da (apron) |
| Db (apron) |
| Dc (apron) |
| E (Leg member) |
| F (Leg member) |
| G (Leg member) |
| H (Leg member) |
| I (Apron rail) |
| J (Stretcher) |
| K (Stretcher) |
| L (Stretcher) |
| M (Drawer top) |
| Table top |

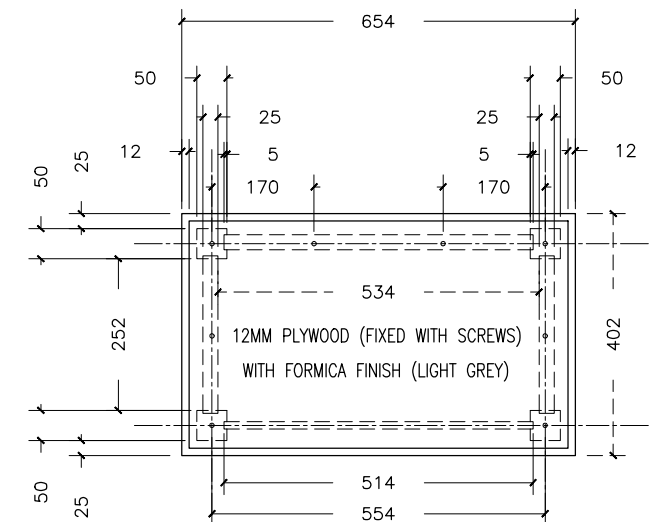
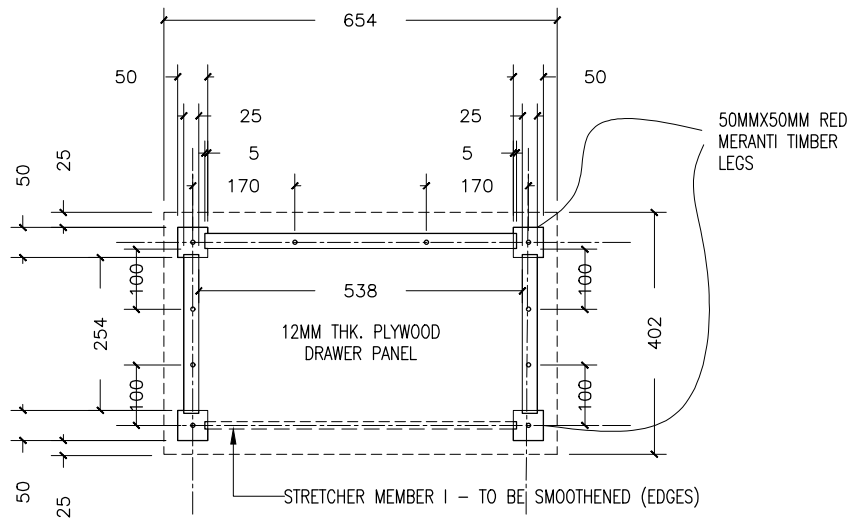
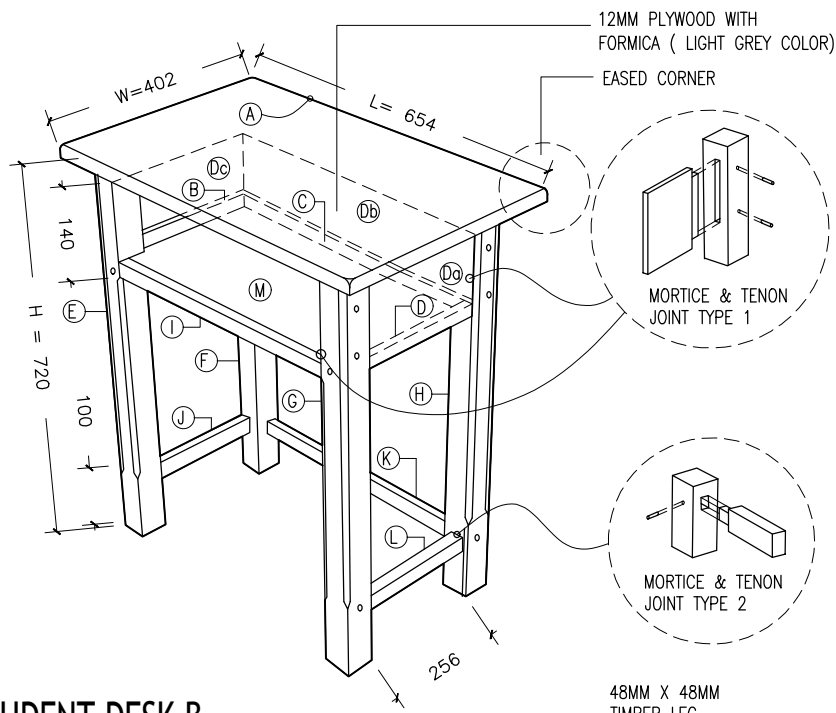

PERSPECTIVE VIEW OF STUDENT DESK B
SCALE 1:100

PLAN (650MM FROM F.F.L)
SCALE 1:100

TOP VIEW
SCALE 1:100

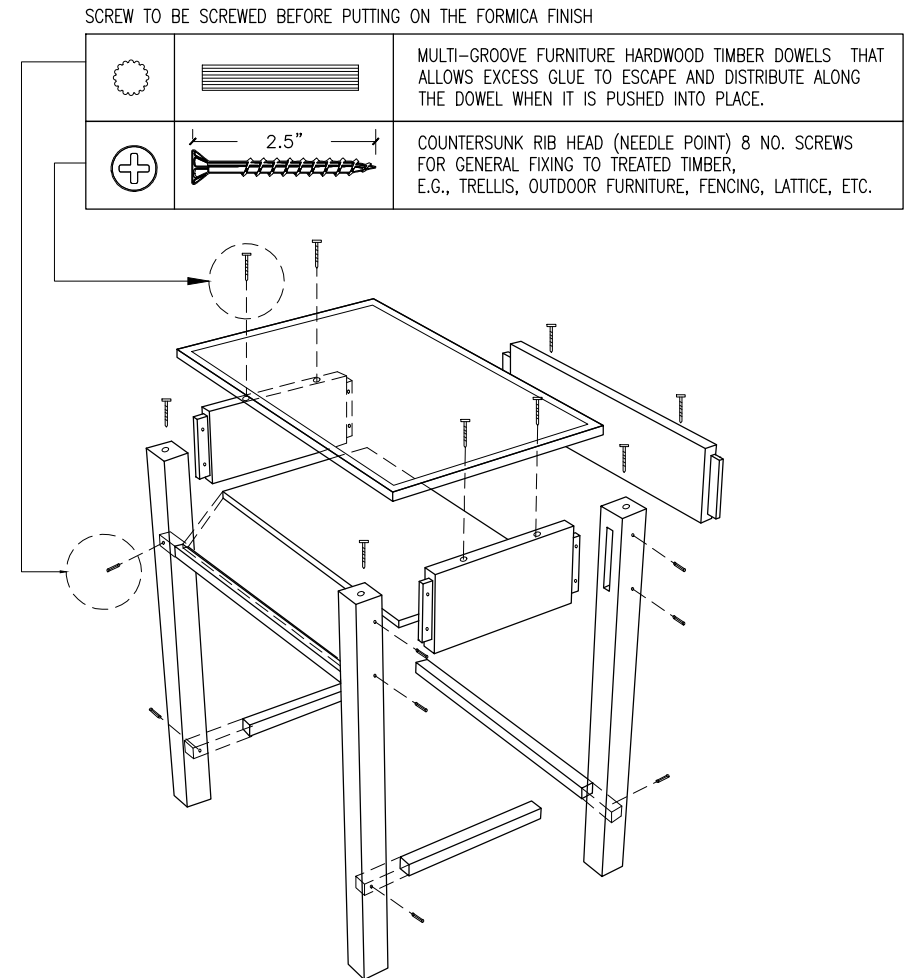

EXPLODED VIEW OF STUDENT DESK B - SCREW AND DOWEL PLAN
SCALE 1:100

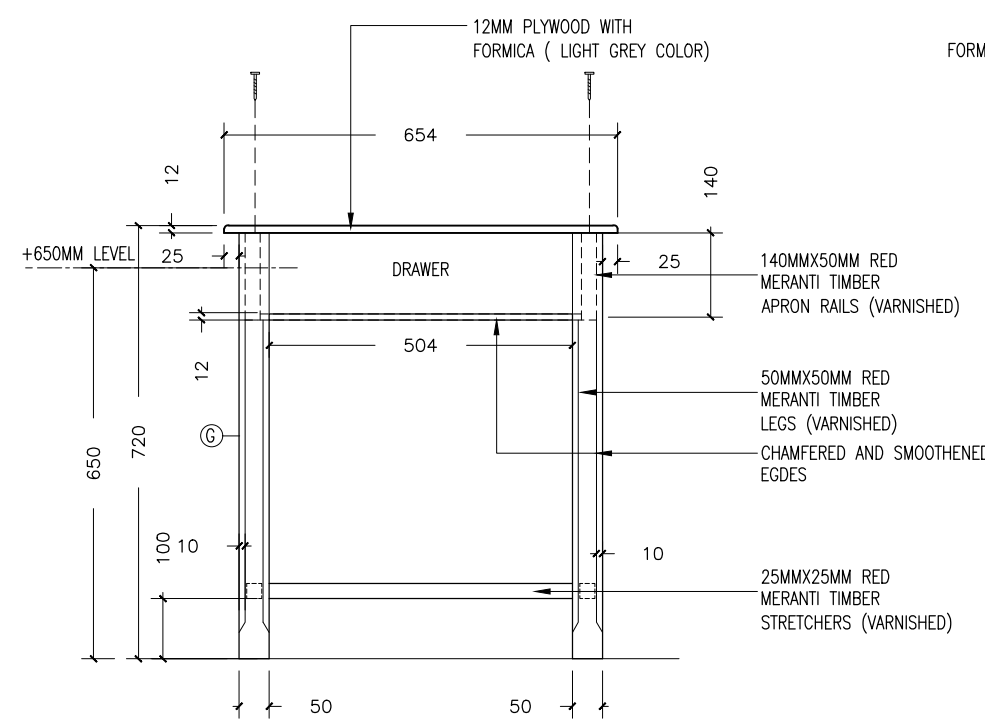

FRONT VIEW
SCALE 1:100

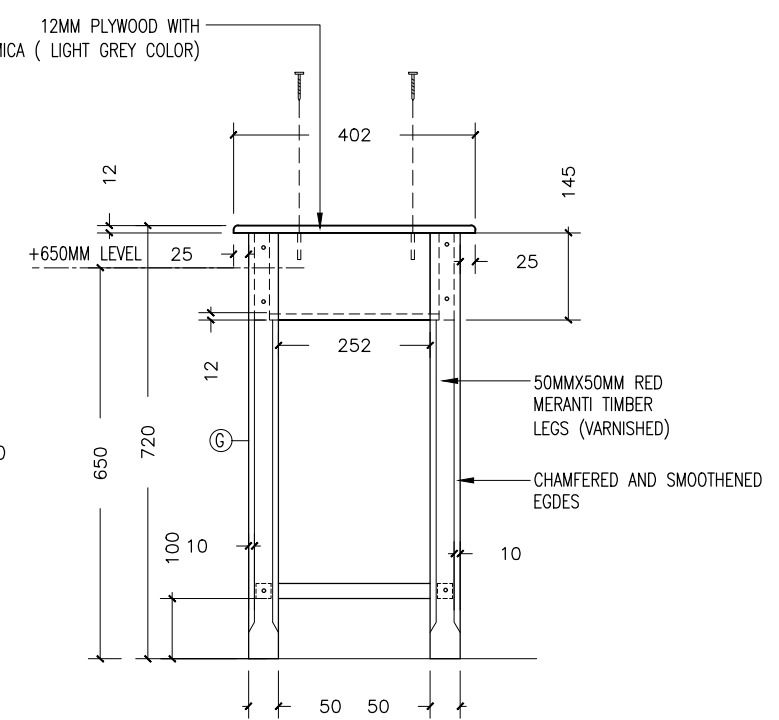

SIDE VIEW
SCALE 1:100

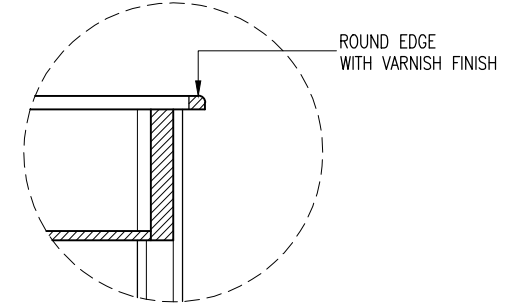
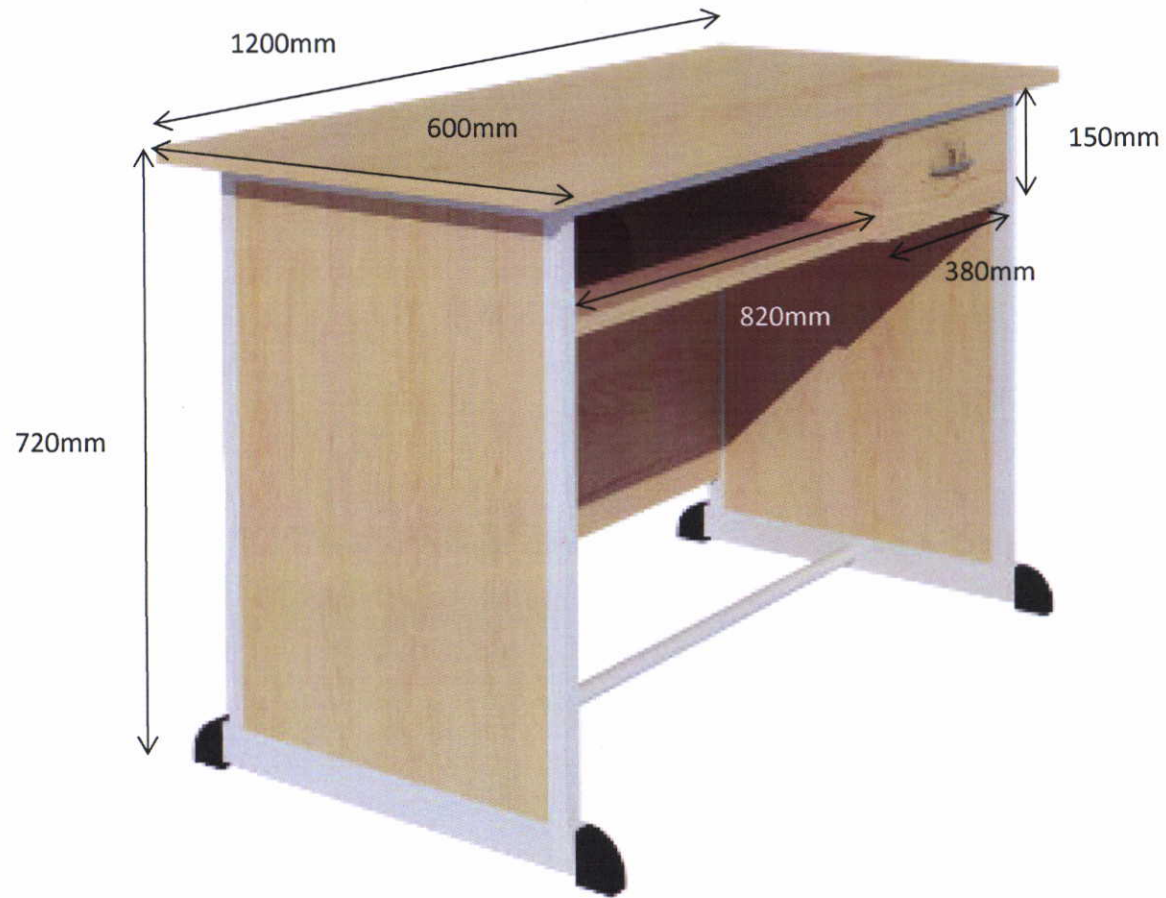

TABLE TOP EDGE FINISH
SCALE 1:100

NOTE (REGARDING VARNISH):

- CLEAN UP THE DUST.
- VACUUM MOST OF THE DUST FROM THE SURFACE, .
- THEN BRUSH VARNISH OVER THE ENTIRE SURFACE, TIPPING IT OFF TO MINIMIZE BRUSH MARKS.
- AFTER THE SEALER DRIES, LIGHTLY SAND THE SURFACES WITH 240- OR 280-GRIT (EXTRA FINE) SANDING PADS OR PAPER.
- THEN APPLY THE SECOND COAT (FINISH COAT)

Teachers' Table



Plastic Chair with Arm

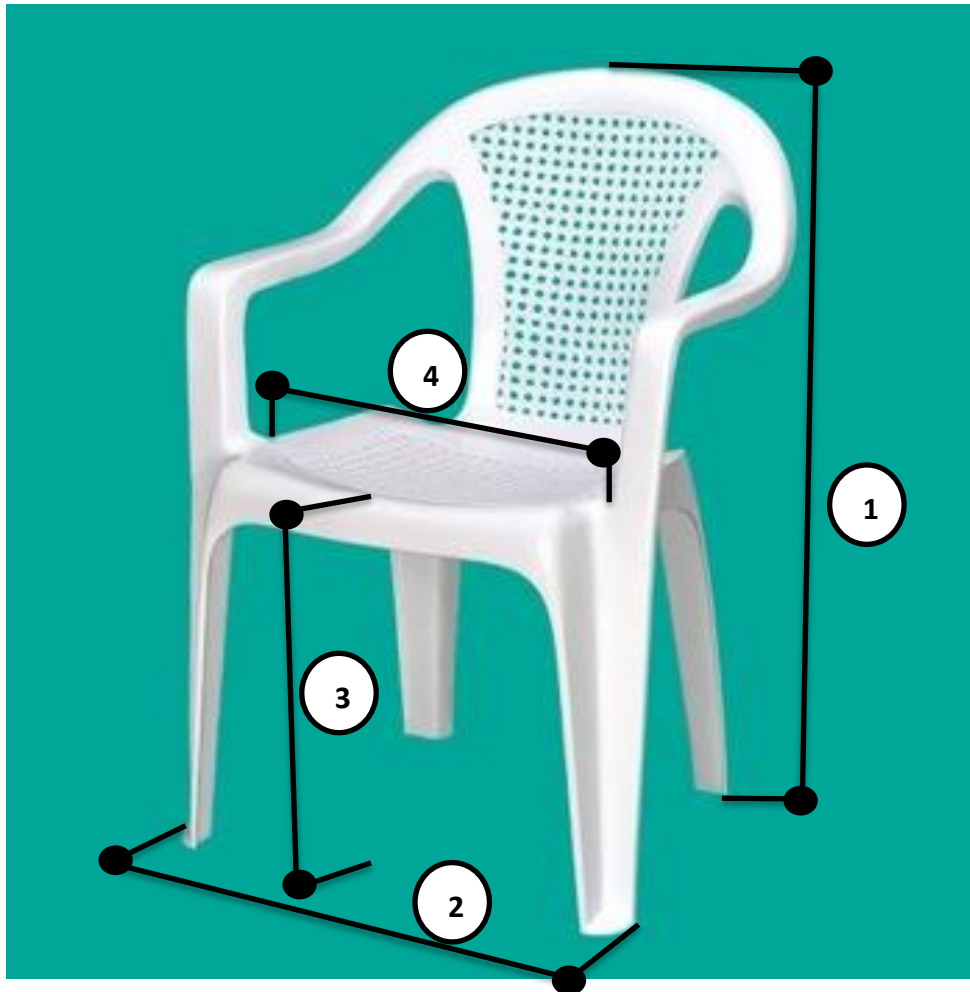

- 1- Total height = 760 mm to 765mm
- 2- Width = 530mm to 534mm
- 3- Seating height = 420mm to 435mm
- 4- Seating width = 380mm to 390mm

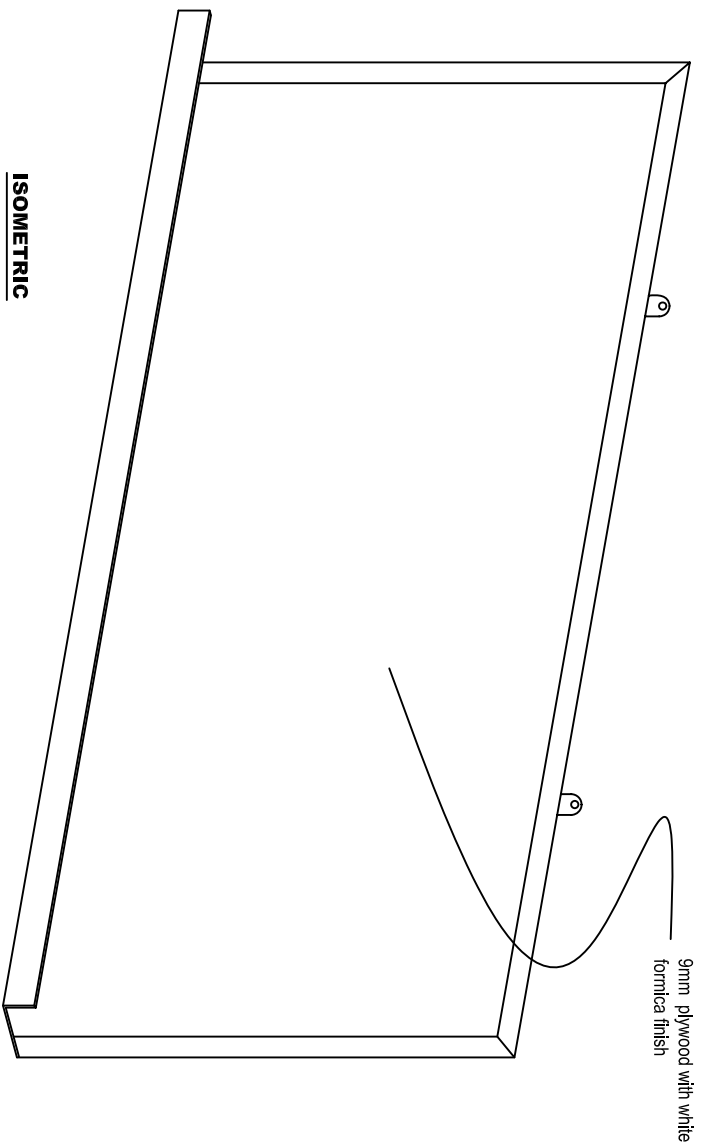
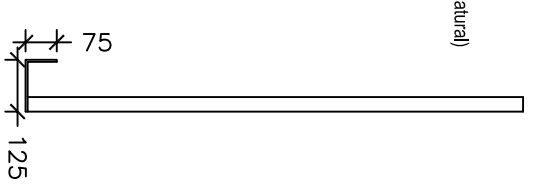
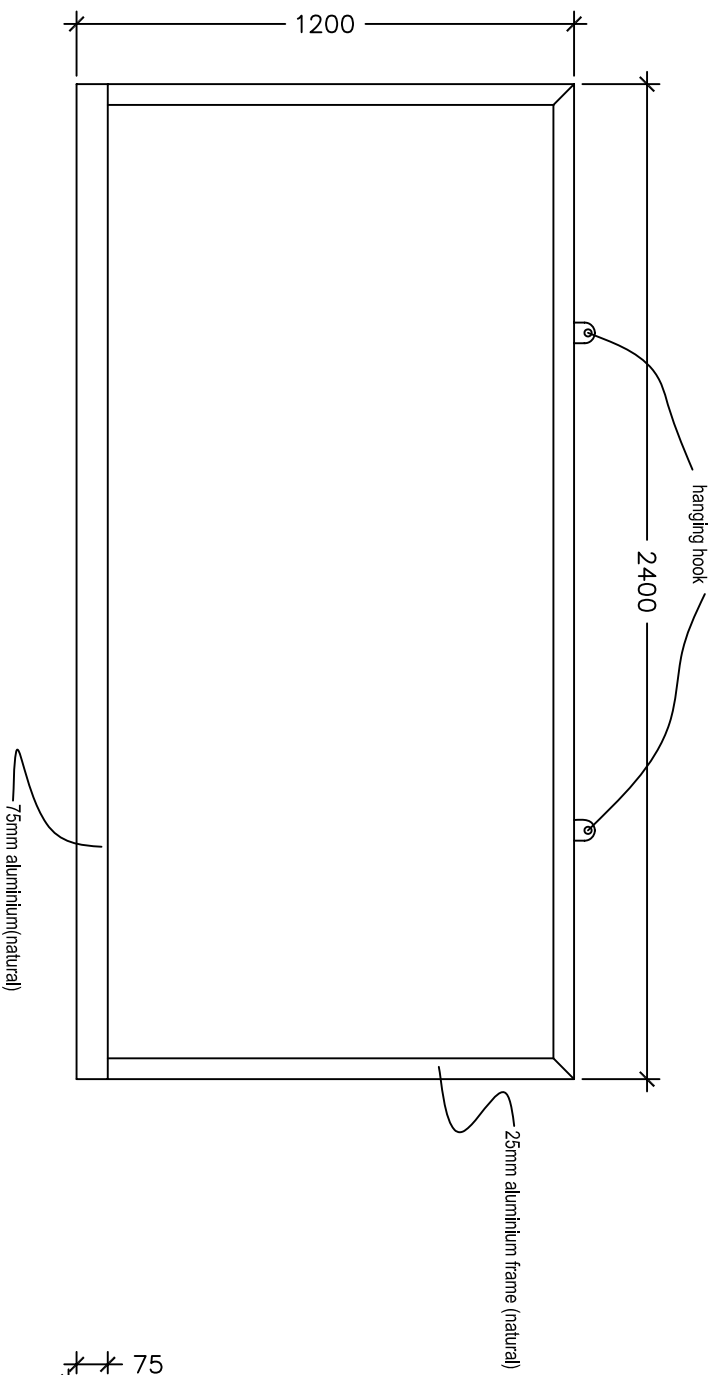

WHITE BOARD

SCALE : AS GIVEN

ISOMETRIC

SCALE : 1:20