

# **HPE Aruba Networking**

## **500R Series Remote Access Points**

Installation Guide



**Hewlett Packard**  
Enterprise

## Copyright Information

© Copyright 2026 Hewlett Packard Enterprise Development LP.

## Open Source Code

This product includes code licensed under certain open source licenses which require source compliance. The corresponding source for these components is available upon request. This offer is valid to anyone in receipt of this information and shall expire three years following the date of the final distribution of this product version by Hewlett Packard Enterprise Company. To obtain such source code, please check if the code is available in the HPE Software Center at <https://myenterpriselicense.hpe.com/cwp-ui/software> but, if not, send a written request for specific software version and product for which you want the open source code. Along with the request, please send a check or money order in the amount of US \$10.00 to:

Hewlett Packard Enterprise Company  
Attn: General Counsel  
WW Corporate Headquarters  
1701 E Mossy Oaks Rd, Spring, TX 77389  
United States of America.



---

<b>Contents</b> .....	<b>1</b>
<b>About This Guide</b> .....	<b>2</b>
Guide Overview .....	2
Related Documentation .....	2
Contacting Support .....	2
<b>Hardware Overview</b> .....	<b>3</b>
Package Contents .....	3
Access Point Views .....	3
LEDs .....	5
Primary DC Power Port (Circular) .....	6
Alternate DC Power Port (USB-C) .....	7
Ethernet Ports .....	8
USB Type-A Host Port .....	8
Reset Button .....	8
USB Micro-B Console Port (Proprietary) .....	8
Kensington Lock Slot .....	9
<b>Access Point Installation</b> .....	<b>10</b>
Software .....	10
Verifying Post-Installation Connectivity .....	10
<b>Electrical and Environmental Specifications</b> .....	<b>11</b>
Electrical .....	11
Environmental .....	11
Regulatory Information .....	11
Safety and Regulatory Compliance .....	11
Brazil .....	12
Canada .....	12
EU and UK Regulatory Conformity .....	12
European Union and United Kingdom .....	13
México .....	13
Нормативные требования Евразийского Экономического Союза .....	13
Ukraine .....	14
Taiwan .....	14
UKCA .....	14
United States .....	14
Medical .....	15

This document describes the hardware features of the HPE Aruba Networking 500R Series Remote Access Points. It provides a detailed overview of the physical and performance characteristics of each access point model and explains how to install the access point.

## Guide Overview

- [Hardware Overview](#) provides a detailed hardware overview of the HPE Aruba Networking 500R Series Remote Access Points .
- [Access Point Installation](#) describes how to install the HPE Aruba Networking 500R Series Remote Access Points.
- [Electrical and Environmental Specifications](#) lists the HPE Aruba Networking 500R Series Remote Access Points's technical specifications, safety, and regulatory compliance information.

## Related Documentation

You require the following documents for the complete management of HPE Aruba Networking 500R Series Remote Access Points.

- Latest document of the software user guide:  
<https://www.arubanetworks.com/techdocs/ArubaDocPortal/content/cons-aos-home.htm>
- CLI bank: <https://www.arubanetworks.com/techdocs/CLI-Bank/Content/Home.htm>

## Contacting Support

**Table 1:** *Contact Information*

Main Site	<a href="http://arubanetworks.com">arubanetworks.com</a>
Support Site	<a href="https://networkingsupport.hpe.com/home">https://networkingsupport.hpe.com/home</a>
Airheads Social Forums and Knowledge Base	<a href="http://community.arubanetworks.com">community.arubanetworks.com</a>
North American Telephone	1-800-943-4526 (Toll Free) 1-408-754-1200
International Telephone	<a href="http://arubanetworks.com/support-services/contact-support/">arubanetworks.com/support-services/contact-support/</a>
Software Licensing Site	<a href="http://lms.arubanetworks.com">lms.arubanetworks.com</a>
End-of-life Information	<a href="http://arubanetworks.com/support-services/end-of-life/">arubanetworks.com/support-services/end-of-life/</a>
Security Incident Response Team	Site: <a href="http://arubanetworks.com/support-services/security-bulletins/">arubanetworks.com/support-services/security-bulletins/</a> Email: <a href="mailto:aruba-sirt@hpe.com">aruba-sirt@hpe.com</a>

The HPE Aruba Networking 500R Series access points are dual-radio 802.11ax Wi-Fi 6 remote access points that provide connectivity for both wired and wireless client devices.

## Package Contents

The following materials are included with this product:

- AP-503R Access Point
- AC-to-DC Power Adapter with Country-Specific AC Power Plug

## Access Point Views

**Figure 1** AP-503R Front View

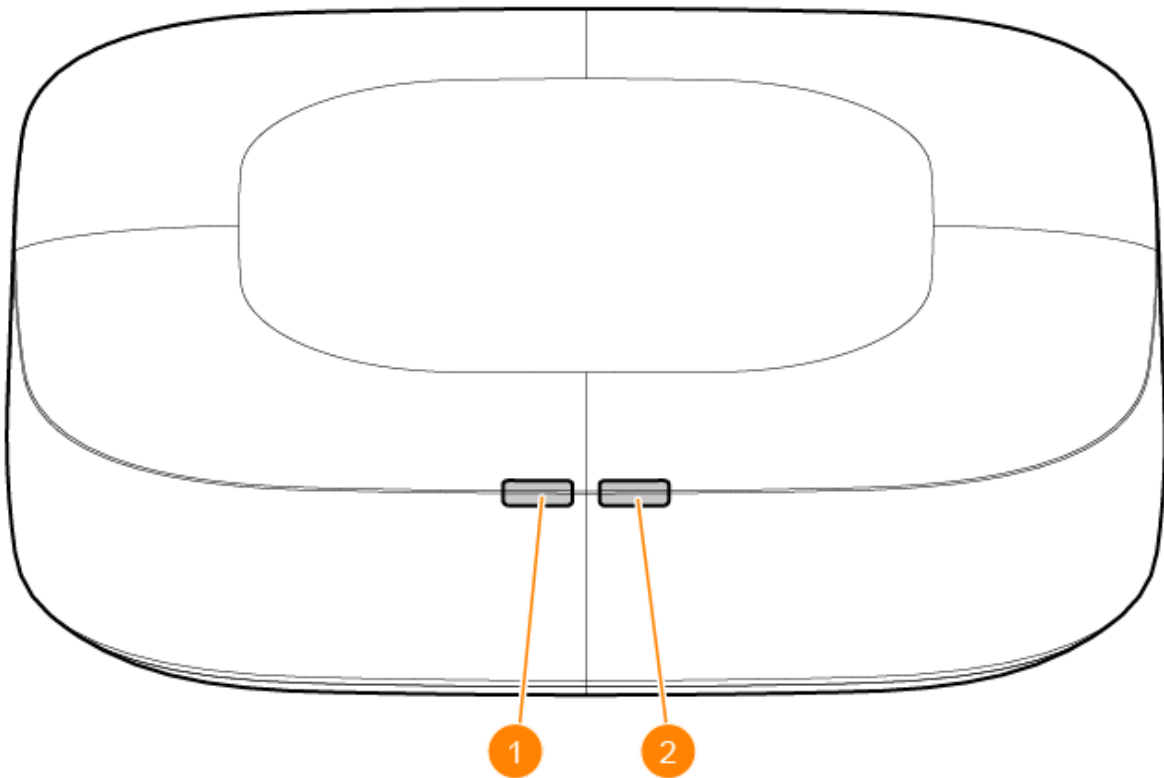

1	System Status LED
2	Radio Status LED

**Figure 2** AP-503R Rear and Side View

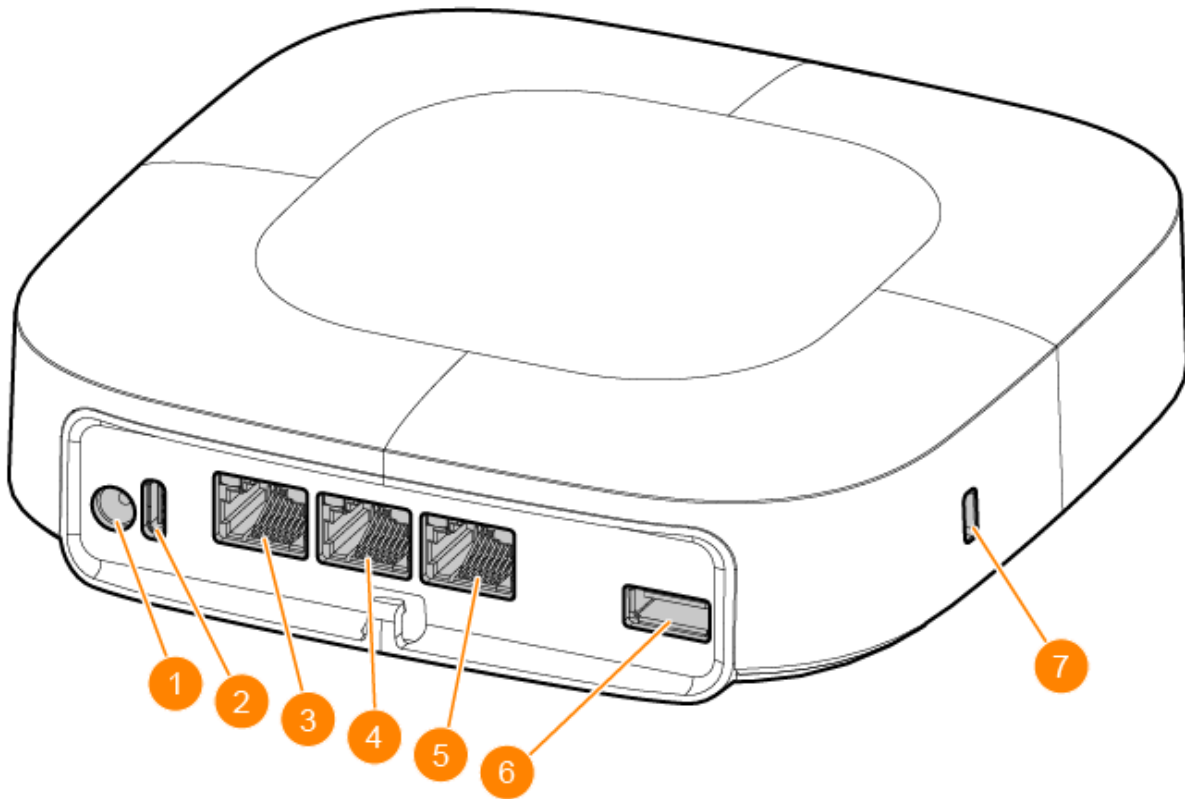

1	Primary DC Power Port (Circular)
2	Alternate DC Power Port (USB-C)
3	E0 Ethernet Port (Uplink)
4	E1 Ethernet Port (Downlink)
5	E2 Ethernet Port (Downlink)
6	USB Type-A Host Port
7	Kensington Lock Slot

**Figure 3** AP-503R Bottom View

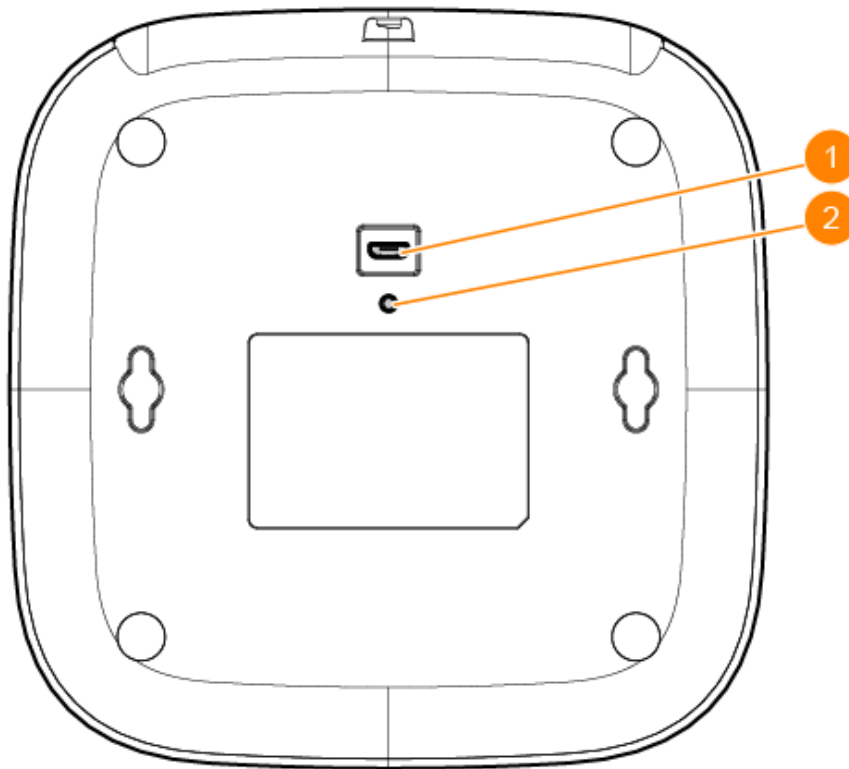

1	USB Micro-B Console Port (proprietary)
2	Reset Button

## LEDs

The LEDs located on the front panel of the access point indicate the system and radio status of the access point.

### System Status LED

The system status LED indicates the system status of the access point.

**Table 2:** System Status LED

Color/State	Meaning
Off	Access point powered off
Green - blinking <sup>1</sup>	Access point booting, not ready
Green - solid	Access point ready, fully functional
Red	System error condition - Immediate attention required

# Radio Status LED

The radio status LED indicates the radio status of the access point.

**Table 3:** Radio Status LED

Color/State	Meaning
Off	Device powered off, or both radios disabled
Green- solid	Both radios enabled in access mode
Green- blinking	One radio enabled in access mode, the other disabled
Amber- solid	Both radio enabled in monitor mode
Amber- blinking	One radio enabled in monitor mode, the other disabled
Alternating green/amber <sup>2</sup>	One radio enabled in access mode, the other in monitor mode

1. Blinking: one second on, one second off, 2 seconds cycle.
2. Alternating: one second each color, 2 seconds cycle.

## LED Display Settings

The LEDs have three operating modes that can be selected in the system management software:

- Normal mode: default after power on. Refer to [Table 2](#) and [Table 3](#).
- Off mode: the LEDs are all off
- Blink mode: both LEDs blink green (synchronized)

Pressing the reset button for less than 10 seconds during normal operation will toggle the LED mode between “normal” (default after power on) and “off” mode.



---

Pressing the reset button for longer than 10 seconds may cause the access point to reset and return to the factory default state.

---

## Primary DC Power Port (Circular)

This DC power port is designed for use with the power adapter (part number R9D91A) included in the package.

After inserting the L-shape DC connector of the power adapter into the DC power port, rotate the DC connector by 90 degrees and route the power cord through the cable hook on the access point. See [Figure 4](#) and [Figure 5](#).

**Figure 4** Connecting Power Adapter to DC Power Port

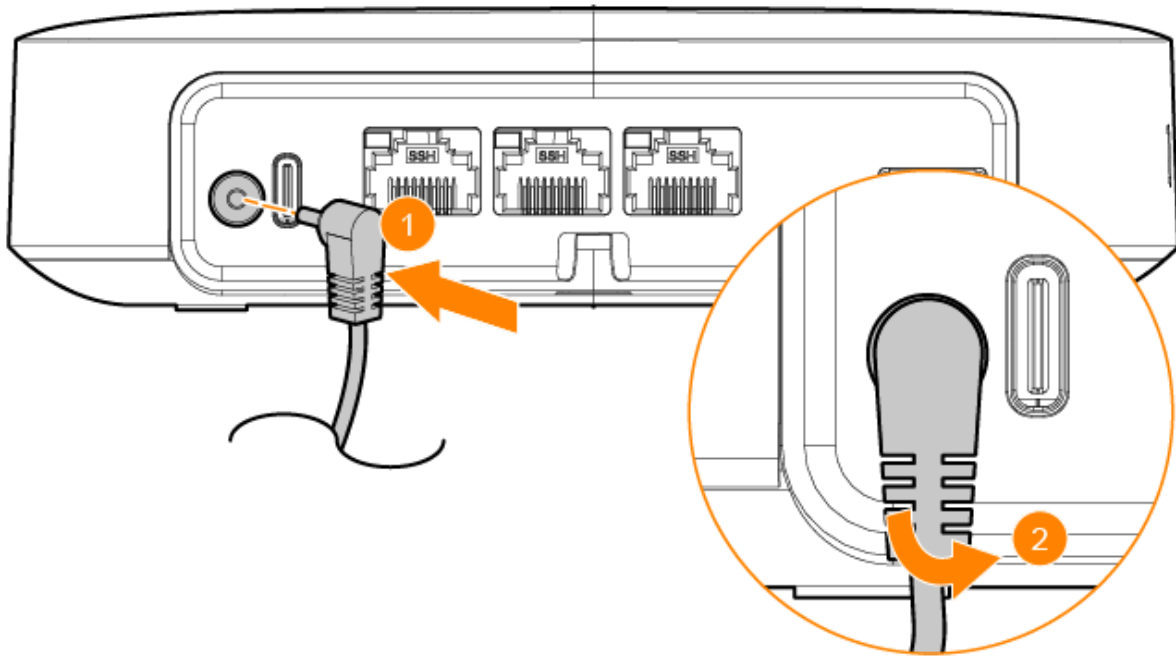

**Figure 5** Routing Power Cord through Cable Hook

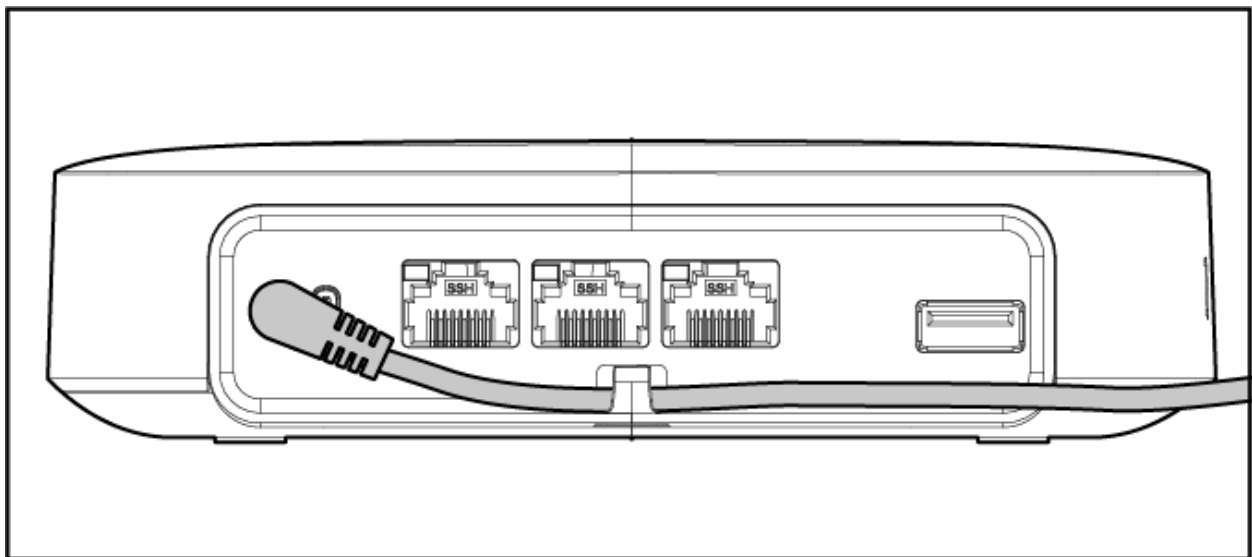

## Alternate DC Power Port (USB-C)

The USB-C port is designed to offer an alternate way to provide DC power to the AP-503R access point by using a compatible 5V/3A USB-C power adapter.

# Ethernet Ports

The AP-503R access point has three Ethernet ports (E0 - E2), shown in [Figure 2](#).

- The E0 port is a 100/1000Base-T auto-sensing MDI/MDIX uplink port .
- The E1 and E2 ports are 100/1000Base-T auto-sensing MDI/MDIX downlink ports.

## Ethernet Port LEDs

Each of the E0-E2 ports has one LED located on the top left corner of the port, indicating the network status or activity on the port. See [Figure 2](#) and [Table 3](#)

**Table 4:** *Ethernet Port LEDs*

LED	Color/State	Meaning
Left	Off	Meet one of the following conditions: <ul style="list-style-type: none"><li>■ access point is powered off</li><li>■ port is disabled</li><li>■ no link established</li></ul>
	Green - blinking	Activity detected on the port
	Green - solid	Link established at optimum speed (1Gbps)
	Amber - solid	Link established at reduced speed (100Mbps)

## USB Type-A Host Port

The USB Type-A host port supports the HPE Aruba Networking MDM-USB-LTE modem, HPE Aruba Networking AP-USB-ZB IOT radio module and other compatible peripherals. When active, this USB port can supply up to 5W/1A to a connected device.

## Reset Button

The reset button can be used to reset the access point to factory default settings or turn off/on the LED display.

Use one of the following methods to reset the access point to factory default settings:

- To reset during normal operation:
  - Hold the reset button for more than 10 seconds while the access point is running.
  - Release the reset button.
- To reset during power up, hold the reset button while the access point is powering up.

The system status LED will flash again within 15 seconds indicating that the reset is completed. The access point will now continue to boot with the factory default settings.

To toggle the system status LED between “normal” (default after power on) and “off” mode, during the normal operation of the access point, shortly press the reset button for less than 10 seconds.

## USB Micro-B Console Port (Proprietary)

To create a console connection to the access point, follow these steps:

1. Connect the console port on the access point to the serial port on the computer using the proprietary HPE Aruba Networking AP-CBL-SERU cable or AP-MOD-SERU module, which need to be purchased separately.
2. Start the terminal emulation software on the computer and configure a new serial session with the following settings:
  - Speed: 9600 bps
  - Data bits: 8
  - Stop bits: 1
  - Parity: None
  - Flow control: None
3. Start the terminal emulation session.
4. Press **Enter** once. If the connection is successful, you are prompted to login.

For this console port pin-out details, refer to [Figure 6](#).

**Figure 6** *Micro-B Console Port Pin-out*

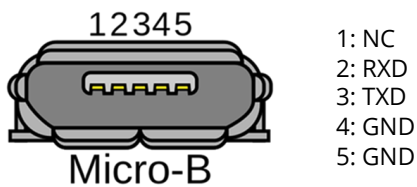

If needed, the AP console driver can be found at the <https://networkingsupport.hpe.com/home>

## Kensington Lock Slot

The AP-503R access point is equipped with a Kensington lock slot for additional physical security.



CAUTION

---

All HPE Aruba Networking access points should be professionally installed by a professional installer. The installer is responsible for meeting applicable national and electrical codes. Failure to properly install this product may result in physical injury and/or damage to property.

---



CAUTION

---

Tous les points d'accès HPE Aruba Networking doivent impérativement être installés par un professionnel agréé. Ce dernier doit s'assurer que l'appareil est mis à la terre et que le circuit de mise à la terre est conforme aux codes électriques nationaux en vigueur. Le fait de ne pas installer correctement ce produit peut entraîner des blessures corporelles et / ou des dommages matériels.

---



CAUTION

---

For indoor use only. The access point, power adapter, and all connected cables are not to be installed outdoors. This stationary device is intended for stationary use in partly temperature controlled weather-protected environments (class 3.2 per ETSI 300 019).

---

You can put the AP-503R access point on any flat surface such as a desktop.

## Software

For instructions on choosing operating modes and initial software configuration, refer to the [AP Software Quick Start Guide](#).



NOTE

---

HPE Aruba Networking access points are classified as radio transmission devices, and are subject to government regulations of the host country. The network administrator(s) is/are responsible for ensuring that configuration and operation of this equipment is in compliance with their country's regulations. For a complete list of approved channels in your country, refer to the HPE Aruba Networking Downloadable Regulatory Table at <https://www.arubanetworks.com/techdocs/DRT/content/home.htm>.

---

## Verifying Post-Installation Connectivity

The integrated LEDs on the access point can be used to verify that the access point is receiving power and initializing successfully. See , and .

### Electrical

- Ethernet:
  - E0/E1/E3 port: 100/1000Base-T auto-sensing MDI/MDX wired RJ45 network connectivity port
- Power
  - 12V DC power interface, support powering through AC-to-DC power adapter
  - Maximum power consumption: Refer to datasheet

### Environmental

- Operating
  - Temperature: 0°C to +40°C (+32°F to +104°F)
  - Humidity: 5% to 95% non-condensing
- Storage
  - Temperature: -25°C to 55°C (-13°F to 131°F)
  - Humidity: 10% to 100% non-condensing

### Regulatory Information

For the purpose of regulatory compliance certifications and identification, this product has been assigned a unique regulatory model number (RMN). The regulatory model number can be found on the product nameplate label, along with all required approval markings and information. When requesting compliance information for this product, always refer to this regulatory model number. The regulatory model number RMN is not the marketing name or model number of the product.

The following regulatory model numbers apply to the 500R Series

- AP-503R RMN: APINR503

---

Changes or modifications not expressly approved by the party responsible for compliance could void the user's authority to operate this equipment.

---

Toute modification effectuée sur cet équipement sans l'autorisation expresse de la partie responsable de la conformité est susceptible d'annuler son droit d'utilisation.

---



### Safety and Regulatory Compliance

---

**FCC Statement:** Improper termination of access points installed in the United States configured to non-US model controllers will be in violation of the FCC grant of equipment authorization. Any such willful or intentional violation may result in a requirement by the FCC for immediate termination of operation and may be subject to forfeiture (47 CFR 1.80).

---





---

RF Radiation Exposure Statement: This equipment complies with RF radiation exposure limits. This equipment should be installed and operated with a minimum distance of 7.87 inches ( 20 cm) between the radiator and your body for 2.4 GHz and 5 GHz operations. This transmitter must not be co-located or operating in conjunction with any other antenna or transmitter.

---



Déclaration e la concernant l'exposition aux rayonnements à fréquence radioélectrique: Cet appareil est conforme aux limites d'exposition aux rayonnements FR établies par la FCC. Il doit être installé et utilisé à une distance minimale de 20 cm (7.87 pouces) entre le radiateur et votre corps, qu'il opère sur la bande 2,4 GHz ou 5GHz. Cet émetteur ne doit pas être installé ou utilisé à proximité immédiate d'une autre antenne ni d'un autre transmetteur.

---



The device could automatically discontinue transmission in case of absence of information to transmit, or operational failure. Note that this is not intended to prohibit transmission of control or signaling information or the use of repetitive codes where required by the technology.

---

## Brazil

Este equipamento não tem direito à proteção contra interferência prejudicial e não pode causar interferência em sistemas devidamente autorizados.

Para mais informações, consulte o site da Anatel: <https://www.gov.br/anatel/pt-br>

## Canada

This Class B digital apparatus meets all of the requirements of the Canadian Interference-Causing Equipment Regulations.

This device contains licence-exempt transmitter(s)/receiver(s) that comply with Innovation, Science and Economic Development Canada's licence-exempt RSS(s). Operation is subject to the following two conditions: (1) This device may not cause interference; and (2) This device must accept any interference, including interference that may cause undesired operation of the device.

## Canada

Cet appareil numérique de classe B respecte toutes les exigences du Règlement sur le matériel brouilleur du Canada.

Cet appareil contient des émetteurs / récepteurs exemptés de licence qui sont conformes aux RSS exempts de licence d'Innovation, Sciences et Développement économique Canada. Son fonctionnement est soumis aux deux conditions suivantes: (1) ce périphérique ne doit pas provoquer d'interférences, et (2) ce périphérique doit accepter toute interférence, y compris les interférences susceptibles de provoquer un dysfonctionnement.

## EU and UK Regulatory Conformity

The Declaration of Conformity made under Radio Equipment Directive 2014/53/EU as well as the United Kingdom's Radio Equipment Regulations 2017/UK is available for viewing below. Select the document that corresponds to your device's model number as it is indicated on the product label.

- [EU & UK Declaration of Conformity](#)

Compliance is only assured if the HPE Aruba Networking approved accessories as listed in the ordering guide are used.

<https://www.arubanetworks.com>.

## Wireless Channel Restrictions

5150-5350MHz band is limited to indoor only in the following countries; Austria (AT), Belgium (BE), Bulgaria (BG), Croatia (HR), Cyprus (CY), Czech Republic (CZ), Denmark (DK), Estonia (EE), Finland (FI), France (FR), Germany (DE), Greece (GR), Hungary (HU), Iceland (IS), Ireland (IE), Italy (IT), Latvia (LV), Liechtenstein (LI), Lithuania (LT), Luxembourg (LU), Malta (MT), Netherlands (NL), Norway (NO), Poland (PL), Portugal (PT), Romania (RO), Slovakia (SK), Slovenia (SL), Spain (ES), Sweden (SE), Switzerland (CH), Turkey (TR), United Kingdom (UK (NI)).

Radio	Frequency Range MHz	Max EIRP
Wi-Fi	2412-2472	20 dBm
	5150-5250	23 dBm
	5250-5350	23 dBm
	5470-5725	30 dBm
	5725-5850	14 dBm



Lower power radio LAN product operating in 2.4 GHz and 5 GHz bands. Please refer to the User Guide for details on restrictions.

## European Union and United Kingdom

This device is limited for indoor use. Use in trains with metal-coated windows (or similar structures made of materials with comparable attenuation characteristic) and aircraft is permitted. Operations in the 6GHz band are blocked by firmware for some countries pending adoption of spectrum. Refer to DRT release notes for details.

## México

La operación de este equipo está sujeta a las siguientes dos condiciones: (1) es posible que este equipo o dispositivo no cause interferencia perjudicial y (2) este equipo o dispositivo debe aceptar cualquier interferencia, incluyendo la que pueda causar su operación no deseada.

## Нормативные требования Евразийского Экономического Союза

### Russia



HPE Russia: ООО "Хьюлетт Паккард Энтерпрайз" Российская Федерация, 125171, г. Москва, Ленинградское шоссе, 16А, стр.3, Телефон: +7 499 403 4248  
Факс: +7 499 403 4677

'HPE Kazakhstan': ТОО «Хьюлетт-Паккард (К)», Республика Казахстан, 050040, г. Алматы, Бостандыкский район, проспект Аль-Фараби, 77/7, Телефон/факс: + 7 727 355 35 50

## Kazakhstan

ЖШС "Хьюлетт Паккард Энтэрпрайз" Ресей Федерациясы, 125171, Мәскеу, Ленинград тас жолы, 16А блок 3, Телефон: +7 499 403 4248 Факс: +7 499 403 4677

ЖШС «Хьюлетт-Паккард (К)», Қазақстан Республикасы, 050040, Алматы к., Бостандық ауданы, Әл-Фараби даңғылы, 77/7, Телефон/факс: +7 (727) 355 35 50

## Ukraine

Hereby, Hewlett Packard Enterprise Company declares that the radio equipment type [The Regulatory Model Number [RMN] for this device can be found in the [Regulatory Information](#) section of this document] is in compliance with Ukrainian Technical Regulation on Radio Equipment, approved by resolution of the CABINET OF MINISTERS OF UKRAINE dated May 24, 2017, No. 355. The full text of the UA declaration of conformity is available at the following internet address:

<https://certificates.ext.hpe.com/public/certificates.html>.

ХЬЮЛЕТТ ПАКАРД ЕНТЕРПРАЗ, 6280 АМЕРИКА ЦЕНТР Д-Р, САН-ХОСЕ, КАЛИФОРНИЯ 95002, США

## Taiwan

第十二條

經型式認證合格之低功率射頻電機，非經許可，公司，商號或使用者均不得擅自變更頻率、加大功率或變更原設計之特性及功能。

第十四條

低功率射頻電機之使用不得影響飛航安全及干擾合法通信；經發現有干擾現象時，應立即停用，並改善至無干擾時方得繼續使用。

前項合法通信，指依電信法規定作業之無線電通信。低功率射頻電機須忍受合法通信或工業、科學及醫療用電波輻射性電機設備之干擾。

- 1.應避免影響附近雷達系統之操作。
- 2.高增益指向性天線只得應用於固定式點對點系統
- 3.電磁波暴露量 MPE 標準值  $1 \text{ mW/cm}^2$ , 送測產品實測值為:  $0.1249 \text{ mW/cm}^2$

## UKCA



EU & UK Regulatory Contact:

HPE, Postfach 0001, 1122 Wien, Austria

## United States

This device complies with Part 15 of the FCC Rules. Operation is subject to the following two conditions: (1) this device may not cause harmful interference, and (2) this device must accept any interference received, including interference that may cause undesired operation.

This equipment has been tested and found to comply with the limits for a Class B digital device, pursuant to Part 15 of the FCC Rules. These limits are designed to provide reasonable protection against

harmful interference in a residential installation. This equipment generates, uses and can radiate radio frequency energy and, if not installed and used in accordance with the manufacturer's instructions, may cause harmful interference to radio communications. However, there is no guarantee that interference will not occur in a particular installation. If this equipment does cause harmful interference to radio or television reception, which can be determined by turning the equipment off and on, the user is encouraged to try to correct the interference by one or more of the following measures

- Reorient or relocate the receiving antenna.
- Increase the separation between the equipment and receiver.
- Connect the equipment to an outlet on a circuit different from that to which the receiver is connected.
- Consult the dealer or an experienced radio or TV technician for help.

Improper termination of access points installed in the United States configured to a non-US model controller is a violation of the FCC grant of equipment authorization. Any such willful or intentional violation may result in a requirement by the FCC for immediate termination of operation and may be subject to forfeiture (47 CFR 1.80).

The network administrator(s) is/are responsible for ensuring that this device operates in accordance with local/regional laws of the host domain.



---

FCC regulations restrict the operation of this device to indoor use only.

---

## Medical

1. Equipment not suitable for use in the presence of flammable mixtures.
2. Connect to only IEC 60950-1 or IEC 60601-1 certified products and power sources. The end user is responsible for the resulting medical system complies with the requirements of IEC 60601-1.
3. Wipe with a dry cloth, no additional maintenance required.
4. No serviceable parts, the unit must be sent back to the manufacturer for repair.
5. No modifications are allowed without HPE Aruba Networking approval.

## Hong Kong



## Philippines



## Singapore

