

# HPE Aruba Networking 6000 and 6100 Switch Series

Installation and Getting Started Guide



**Hewlett Packard**  
Enterprise

## Copyright Information

© Copyright 2025 Hewlett Packard Enterprise Development LP.

## Open Source Code

This product includes code licensed under certain open source licenses which require source compliance. The corresponding source for these components is available upon request. This offer is valid to anyone in receipt of this information and shall expire three years following the date of the final distribution of this product version by Hewlett Packard Enterprise Company. To obtain such source code, please check if the code is available in the HPE Software Center at <https://myenterpriselicense.hpe.com/cwp-ui/software> but, if not, send a written request for specific software version and product for which you want the open source code. Along with the request, please send a check or money order in the amount of US \$10.00 to:

Hewlett Packard Enterprise Company  
Attn: General Counsel  
WW Corporate Headquarters  
1701 E Mossy Oaks Rd, Spring, TX 77389  
United States of America



## Legal Disclaimer

The resource assets in this document may include abbreviated and/or legacy terminology for products. See [www.arubanetworks.com](http://www.arubanetworks.com) for current and complete product lines and names.

## Notices

The information contained herein is subject to change without notice. The only warranties for Hewlett Packard Enterprise products and services are set forth in the express warranty statements accompanying such products and services. Nothing herein should be construed as constituting an additional warranty. Hewlett Packard Enterprise shall not be liable for technical or editorial errors or omissions contained herein.

Confidential computer software. Valid license from Hewlett Packard Enterprise required for possession, use, or copying. Consistent with FAR 12.211 and 12.212, Commercial Computer Software, Computer Software Documentation, and Technical Data for Commercial Items are licensed to the U.S. Government under vendor's standard commercial license.

Links to third-party websites take you outside the Hewlett Packard Enterprise website. Hewlett Packard Enterprise has no control over and is not responsible for information outside the Hewlett Packard Enterprise website.

## Acknowledgments

All third-party marks are property of their respective owners.

<b>Contents</b>	<b>3</b>
<b>About this document</b>	<b>5</b>
Applicable products	5
Related publications	6
<b>Introducing the switches</b>	<b>7</b>
Front of the switches	7
LED mode select button and indicator LEDs	11
Reset buttons	11
Back of the switches	13
Switch features	13
<b>Installing the switch</b>	<b>16</b>
Shipping the switch in a rack	16
Included parts	16
Installation procedures for 6000 and 6100 switches	19
Installation precautions and guidelines	19
Prepare the installation site	20
Verify that the switch boots correctly	20
Disconnect power from the switch	20
Mount the switch	21
Rack or cabinet mounting	23
Horizontal surface mounting	27
Wall mounting 12G switches	28
Under-table mounting for 12G switch	33
Connect the switch to a power source	34
(Optional) Install transceivers	34
Connect network cables	34
SFP Installation Notes	34
SFP+ installation notes (6100 switch series only)	35
<b>Getting started with switch configuration</b>	<b>36</b>
Recommended minimal configuration	36
<b>Troubleshooting</b>	<b>37</b>
Basic troubleshooting tips	37
Diagnosing with the LEDs	38
Proactive networking	42
Hardware diagnostic tests	44
Testing the switch by resetting it	44
Checking the switch LEDs	44
Checking console messages	44
Testing twisted-pair cabling	44
Testing switch-to-device network communications	44
Testing end-to-end network communications	45
Restoring the factory default configuration	45
Downloading new switch software	45

---

<b>Specifications</b>	<b>46</b>
Environmental specifications	46
Electrical	48
Acoustics	51
Safety and regulatory information	53
Connectivity standards	54
<b>Cabling and technology information</b>	<b>55</b>
Cabling specifications	55
Technology distance specifications	56
Twisted-pair cable/connector pin-outs	56
Straight-through twisted-pair cable for 10 Mbps or 100 Mbps network connections	57
Cable diagram	57
Pin assignments	58
Crossover twisted-pair cable for 10 Mbps or 100 Mbps network connection	58
Cable diagram	58
Pin assignments	59
Straight-through twisted-pair cable for 1000 Mbps network connections	59
Cable diagram	59
Pin assignments	60
<b>Support and Other Resources</b>	<b>61</b>
Accessing Aruba Support	61
Accessing Updates	61
Aruba Support Portal	62
My Networking	62
Warranty Information	62
Regulatory Information	62
Documentation Feedback	62

This document is intended for network administrators and support personnel.



---

The display and command line illustrated in this document are examples and might not exactly match your particular switch or environment.

The switch and accessory drawings in this document are for illustration only, and may not exactly match your particular switch and accessory products.

---

## Applicable products

- HPE Aruba Networking 6000 48G Class4 PoE 4SFP 740W Switch (R9Y03A)
- HPE Aruba Networking 6000 48G Class4 PoE 4SFP 370W Switch (R8N85A)
- HPE Aruba Networking 6000 48G 4SFP Switch (R8N86A)
- HPE Aruba Networking 6000 24G Class4 PoE 4SFP 370W Switch (R8N87A)
- HPE Aruba Networking 6000 24G 4SFP Switch (R8N88A)
- HPE Aruba Networking 6000 12G Class4 PoE 2SFP 139W Switch (R8N89A)
- HPE Aruba Networking CX 6000 48G Class4 PoE 4SFP 1G 740W Switch (R9Y03B)
- HPE Aruba Networking CX 6000 48G Class4 PoE 4SFP 1G 370W Switch (R8N85B)
- HPE Aruba Networking CX 6000 48G 4SFP 1G Switch (R8N86B)
- HPE Aruba Networking CX 6000 24G Class4 PoE 4SFP 1G 370W Switch (R8N87B)
- HPE Aruba Networking CX 6000 24G 4SFP 1G Switch (R8N88B)
- HPE Aruba Networking CX 6000 12G Class4 PoE 2SFP 1G 139W Switch (R8N89B)
- HPE Aruba Networking CX 6000 48G Class4 PoE 4SFP 1G 740W TAA Switch (S4R20A)
- HPE Aruba Networking CX 6000 12G Class4 PoE 2SFP 1G 139W TAA Switch (S4R21A)
- HPE Aruba Networking CX 6000 8G 2SFP 1G Switch (S4R22A)
- HPE Aruba Networking CX 6000 8G Class4 PoE 2SFP 1G 67W Switch (S4R23A)
- HPE Aruba Networking CX 6000 48G Class4 PoE 4SFP 1G 370W TAA Switch (S4R24A)
- HPE Aruba Networking CX 6000 48G 4SFP 1G TAA Switch (S4R25A)
- HPE Aruba Networking CX 6000 24G Class4 PoE 4SFP 1G 370W TAA Switch (S4R26A)
- HPE Aruba Networking CX 6000 24G 4SFP 1G TAA Switch (S4R27A)
- HPE Aruba Networking CX 6000 8G 2SFP 1G TAA Switch (S4R28A)
- HPE Aruba Networking CX 6000 8G Class4 PoE 2SFP 1G 67W TAA (S4R29A)
  
- HPE Aruba Networking 6100 48G Class4 PoE 4SFP+ 740W Switch (R9Y04A)
- HPE Aruba Networking 6100 48G Class4 PoE 4SFP+ 370W Switch (JL675A)
- HPE Aruba Networking 6100 48G 4SFP+ Switch (JL676A)

HPE Aruba Networking 6100 24G Class4 PoE 4SFP+ 370W Switch (JL677A)

HPE Aruba Networking 6100 24G 4SFP+ Switch (JL678A)

HPE Aruba Networking 6100 12G Class4 PoE 2G/2SFP+ 139W Switch (JL679A)

## Related publications

- *Start Here: Installation, Safety, and Regulatory Information for the Aruba 6000 and 6100 Switches and Accessories*
- AOS-CX software manuals
- *Power Over Ethernet (PoE) Planning and Implementation Guide for the ArubaOS-CX Switches*
- [AOS-S and AOS-CX Transceiver Guide](#)

To view and download these publications, visit the Aruba Support Portal at <https://asp.arubanetworks.com/downloads>.

Aruba multiport switches are store-and-forward devices offering low latency for high-speed networking. Certain switch models also support Power over Ethernet (PoE) technologies and full network management capabilities.

This chapter describes these switches with the following information:

- Front of the switches:
  - Network ports
  - Management ports
  - LEDs
  - Buttons
  - SFP and SFP+ (6100) support
- Back of the switches:
  - Power connectors
- Switch features

### Front of the switches

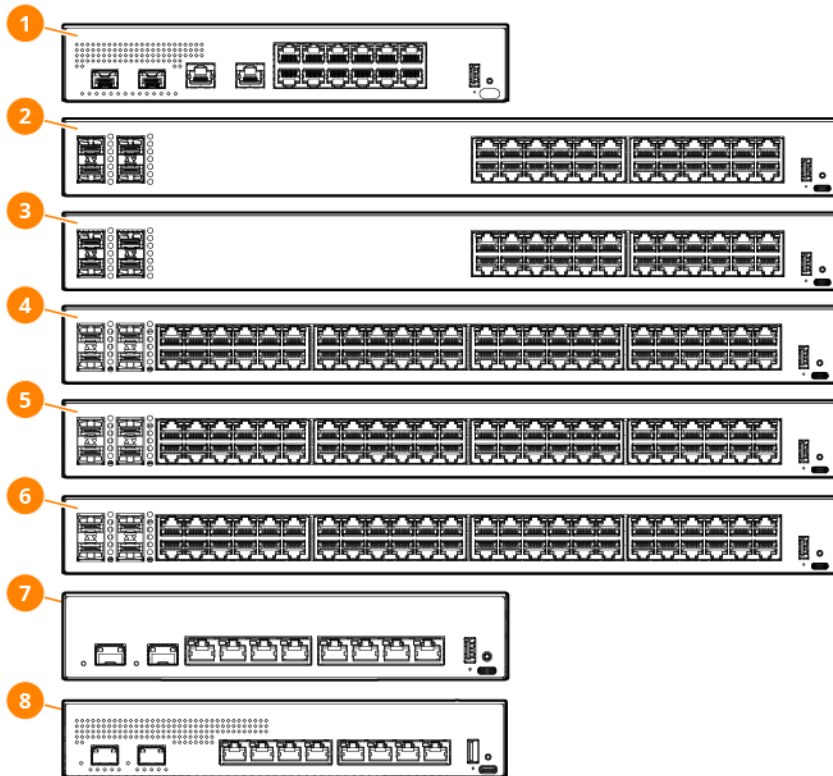

**Table 1: 6000 switches: Label and description**

Label	Description
1	<b>R8N89A</b> Aruba 6000 12G Class4 PoE 2G/2SFP 139W Switch <b>R8N89B</b> HPE Aruba Networking 6000 12G Class4 PoE 2SFP 1G 139W Switch <b>S4R21A</b> HPE Aruba Networking 6000 12G Class4 PoE 2SFP 1G 139W TAA Switch
2	<b>R8N88A</b> Aruba 6000 24G 4SFP Switch <b>R8N88B</b> HPE Aruba Networking 6000 24G 4SFP 1G Switch <b>S4R27A</b> HPE Aruba Networking 6000 24G 4SFP 1G TAA Switch
3	<b>R8N87A</b> Aruba 6000 24G Class4 PoE 4SFP 370W Switch <b>R8N87B</b> HPE Aruba Networking 6000 24G Class4 PoE 4SFP 1G 370W Switch <b>S4R26A</b> HPE Aruba Networking 6000 24G Class4 PoE 4SFP 1G 370W TAA Switch
4	<b>R8N86A</b> Aruba 6000 48G 4SFP Switch <b>R8N86B</b> HPE Aruba Networking 6000 48G 4SFP 1G Switch <b>S4R25A</b> HPE Aruba Networking 6000 48G 4SFP 1G TAA Switch
5	<b>R8N85A</b> Aruba 6000 48G Class4 PoE 4SFP 370W Switch <b>R8N85B</b> HPE Aruba Networking 6000 48G Class4 PoE 4SFP 1G 370W Switch <b>S4R24A</b> HPE Aruba Networking 6000 48G Class4 PoE 4SFP 1G 370W TAA Switch
6	<b>R9Y03A</b> Aruba 6000 48G Class4 PoE 4SFP 740W Switch <b>R9Y03B</b> HPE Aruba Networking 6000 48G Class4 PoE 4SFP 1G 740W Switch <b>S4R20A</b> HPE Aruba Networking 6000 48G Class4 PoE 4SFP 1G 740W TAA Switch
7	<b>S4R22A</b> HPE Aruba Networking 6000 8G 2SFP 1G Switch <b>S4R28A</b> HPE Aruba Networking 6000 8G 2SFP 1G TAA Switch
8	<b>S4R23A</b> HPE Aruba Networking 6000 8G Class4 PoE 2SFP 1G 67W Switch <b>S4R29A</b> HPE Aruba Networking 6000 8G Class4 PoE 2SFP 1G 67W TAA Switch

**Table 2: 6100 switches: Label and description**

Label	Description
1	<b>JL679A</b> Aruba 6100 12G Class4 PoE 2G/2SFP+ 139W Switch
2	<b>JL678A</b> Aruba 6100 24G 4SFP+ Switch
3	<b>JL677A</b> Aruba 6100 24G Class4 PoE 4SFP+ 370W Switch
4	<b>JL676A</b> Aruba 6100 48G 4SFP+ Switch
5	<b>JL675A</b> Aruba 6100 48G Class4 PoE 4SFP+ 370W Switch
6	<b>R9Y04A</b> Aruba 6100 48G Class4 PoE 4SFP+ 740W Switch

## Switch and port LEDs

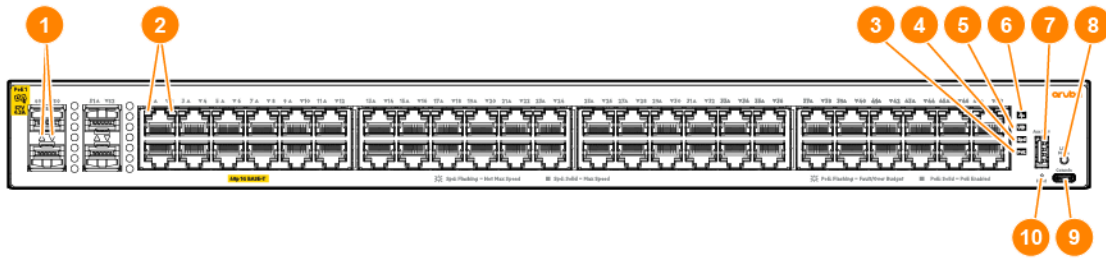

**Table 3:** 6000 Front of switch: Label and description

Label	Description
1	Top and bottom SFP port LEDs
2	Top and bottom RJ45 port LEDs
3	PoE mode LED
4	Speed mode LED
5	UID (Unit Identification) LED
6	Global status LED
7	USB-A port
8	LED mode button
9	USB-C console port
10	Reset button

**Table 4:** 6100 Front of switch: Label and description

Label	Description
1	Top and bottom SFP+ port LEDs
2	Top and bottom RJ45 port LEDs
3	PoE mode LED
4	Speed mode LED
5	UID (Unit Identification) LED
6	Global status LED
7	USB-A port
8	LED mode button

Label	Description
9	USB-C console port
10	Reset button

**Table 5:** Front panel LED behavior

Switch LEDs	Function	State		Meaning
SFP/SFP+ port LEDs *  RJ45 port LEDs *	Displays Link/Activity or Mode information for the port	Startup	OFF	AOS-CX: No valid link SVOS: OFF
		Normal	OFF	No valid link
			Half bright - Green	Valid link indication
			Flash full bright - Green	Indicator of traffic activity. The blink time is roughly proportional to the % of full bandwidth utilization of the port.
		Fault	OFF	No fault
			Flash - Amber	Fault
PoE mode LED *	Indicates Port LEDs are showing PoE information (not applicable for non PoE switches)	Off		PoE mode not selected
		On - Green		PoE mode selected
		Slow Flash - Amber		Hardware failure PoE enabled port, PoE mode not selected
		On - Amber		Hardware failure PoE enabled port, PoE mode selected
Port LEDs **	Indicates the number of stacked switches and identifies the Conductor	Flash - Green		Member is the Conductor
		Flash - Orange		Member is rebooting to join the stack or offline due to error condition
		On - Green		Member joined the stack and is operational
Speed mode LED *	Indicates Port LEDs are showing speed information	Off		Speed mode not selected
		On - Green		Speed mode selected
	Indicates stacking status (applicable for 6100 with no "Stk" mode LED)	On - Green		Switch is in stack mode
UID LED	User-configurable LED	Off		User defined the located LED : OFF

Switch LEDs	Function	State	Meaning
		On/Flash - Blue	User defined the locator LED: On/Flash
Global Status Indicator LED	Overall status of the product	Flash - Green	Self-test in progress during UBOOT, SVOS and AOS-CX
		On - Green	Successfully initialized AOS-CX
		Flash - Amber	Recoverable faults (e.g. fans, PSU fault)
		On - Amber	Critical faults (e.g. exceed temperature limit)
*Press the LED mode button to switch between Link/Activity (default), PoE, or Speed.			
**Applicable only when the 6100 switch is in stack mode.			

## LED mode select button and indicator LEDs

The state of the switch port LEDs is controlled by the LED Mode select button. The current view mode is indicated by the mode LEDs next to the button. To step from one view mode to the next, press the button to cycle through the different modes.

## Reset buttons

The Reset button is recessed from the front panel to prevent accidental activation. The button is accessible through small holes on the top of the front panel using pointed objects, such as unbent paper clips, to push it.



---

Push the unbent paper clip straight in, not inclined and do not over push with excessive force.

---

The behavior of the Reset button changes depending on whether the front -panel factory-reset feature is enabled or left in its default disabled status.

**Table 1:** *Front-Panel Factory-Reset is Enabled*

To accomplish this:	Do this:	This will happen:
Soft Reset	Press and hold the Reset button for less than 5 seconds, then release.	The switch operating system is cleared gracefully. The switch then reboots and runs self-tests.
Hard Reset	Press and hold the Reset button between 5 to 20 seconds, then release.	The switch reboots, similar to a power cycle. A hard reset is used, for example, when the switch CPU is in an unknown state or not responding.
Factory Reset	Press and hold the Reset button between 20 to 25 seconds, then release.	Initiates a hard reset and triggers the factory reset process.

To accomplish this:	Do this:	This will happen:
No action	Press and hold the Reset button for more than 25 seconds.	No action is triggered.

**Table 2:** *Front-Panel Factory-Reset is Disabled*

To accomplish this:	Do this:	This will happen:
Soft Reset	Press and hold the Reset button for less than 5 seconds, then release.	The switch operating system is cleared gracefully. The switch then reboots and runs self-tests.
Hard Reset	Press and hold the Reset button between 5 to 20 seconds, then release.	The switch reboots, similar to a power cycle. A hard reset is used, for example, when the switch CPU is in an unknown state or not responding.
No action	Press and hold the Reset button for more than 20 seconds.	No action is triggered.

# Back of the switches

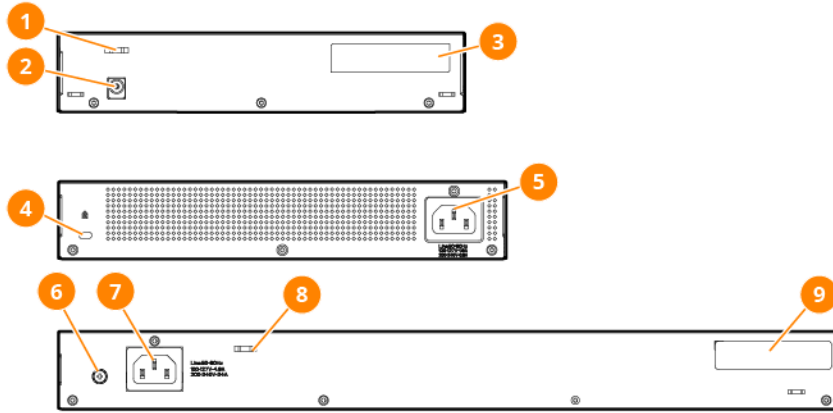

**Table 1:** Back of 6000 and 6100 switches: LED label and description

Label	Description
1	Cable tie eyelet
2	Ground lug
3	Label
4	Kensington lock
5	AC power inlet
6	Ground lug
7	AC power inlet
8	Cable tie eyelet
9	Label

## Switch features

The features of the switches include:

- Combinations of fixed 10/100/1000-T and SFP ports. (6000 switch series)
- Combinations of fixed 10/100/1000-T and SFP/SFP+ ports. (6100 switch series)
- Power over Ethernet (PoE) operation; enabled by default. The following switches power IP phones, wireless access points, indoor web cameras, and more.

HPE Aruba Networking 6000 switch	PoE per port
Aruba 6000 48G Class4 PoE 4SFP 740W Switch (R9Y03A)	Up to 30W, IEEE 802.3af/at 740W available PoE power
Aruba 6000 48G Class4 PoE 4SFP 370W Switch (R8N85A)	Up to 30W, IEEE 802.3af/at 370W available PoE power

HPE Aruba Networking 6000 switch	PoE per port
Aruba 6000 24G Class4 PoE 4SFP 370W Switch (R8N87A)	Up to 30W, IEEE 802.3af/at 370W available PoE power
Aruba 6000 12G Class4 PoE 2G/2SFP 139W Switch (R8N89A)	Up to 30W, IEEE 802.3af/at 139W available PoE power
HPE Aruba Networking 6000 48G Class4 PoE 4SFP 1G 740W Switch (R9Y03B)	Up to 30W, IEEE 802.3af/at 740W available PoE power
HPE Aruba Networking 6000 48G Class4 PoE 4SFP 1G 370W Switch (R8N85B)	Up to 30W, IEEE 802.3af/at 370W available PoE power
HPE Aruba Networking 6000 24G Class4 PoE 4SFP 1G 370W Switch (R8N87B)	Up to 30W, IEEE 802.3af/at 370W available PoE power
HPE Aruba Networking 6000 12G Class4 PoE 2SFP 1G 139W Switch (R8N89B)	Up to 30W, IEEE 802.3af/at 139W available PoE power
HPE Aruba Networking 6000 8G Class4 PoE 2SFP 1G 67W Switch (S4R23A)	Up to 30W, IEEE 802.3af/at 67W available PoE power
HPE Aruba Networking 6000 48G Class4 PoE 4SFP 1G 740W TAA Switchh (S4R20A)	Up to 30W, IEEE 802.3af/at 740W available PoE power
HPE Aruba Networking 6000 12G Class4 PoE 2SFP 1G 139W TAA Switch (S4R21A)	Up to 30W, IEEE 802.3af/at 139W available PoE power
HPE Aruba Networking 6000 48G Class4 PoE 4SFP 1G 370W TAA Switch (S4R24A)	Up to 30W, IEEE 802.3af/at 370W available PoE power
HPE Aruba Networking 6000 24G Class4 PoE 4SFP 1G 370W TAA Switch (S4R26A)	Up to 30W, IEEE 802.3af/at 370W available PoE power
HPE Aruba Networking 6000 8G Class4 PoE 2SFP 1G 67W TAA (S4R29A)	Up to 30W, IEEE 802.3af/at 67W available PoE power

HPE Aruba Networking 6100 switch	PoE per port
Aruba 6100 48G Class4 PoE 4SFP+ 740W Switch (R9Y04A)	Up to 30W, IEEE 802.3af/at 740W available PoE power
Aruba 6100 48G Class4 PoE 4SFP+ 370W Switch (JL675A)	Up to 30W, IEEE 802.3af/at 370W available PoE power
Aruba 6100 24G Class4 PoE 4SFP+ 370W Switch (JL677A)	Up to 30W, IEEE 802.3af/at 370W available PoE power
Aruba 6100 12G Class4 PoE 2G/2SFP+ 139W Switch (JL679A)	Up to 30W, IEEE 802.3af/at 139W available PoE power

- Plug-and-play networking: All ports are enabled by default. Connect the network cables to active network devices and your switched network is operational.
- Auto MDI/MDI-X on all twisted-pair ports (10/100/1000), meaning that all connections can be made using straight-through twisted-pair cables. Cross-over cables are not required, although they will also

work. The pin operation of each port is automatically adjusted for the attached device. If the switch detects that another switch or hub is connected to the port, it configures the port as MDI. If the switch detects that an end node device is connected to the port, it configures the port as MDI-X. (See the appendixes for recommended or required cabling.)

- Automatically negotiated full-duplex operation for the 10/100/1000 RJ-45 ports when connected to other auto-negotiating devices. The SFP and SFP+ ports always operate at full duplex.
  - Easy management of the switch through several available interfaces:
    - **Console interface:** A full-featured, easy-to-use, VT-100 terminal interface for out-of-band or serial switch management. There is a single serial console port on the switch, using a USB Type-C connector. This port is used to connect a console to the switch. Use a common USB to USB-C cable (must be data capable). The console can be a PC or workstation running a VT-100 terminal emulator, or a VT-100 terminal. The console is also available via USB-A port using USB to Serial Adapter.
    - **Auxiliary (Aux) port:** An auxiliary port is available for downloading switch software code. This port uses a USB Type-A connector.
    - **Web browser interface:** An easy-to-use built-in graphical interface that can be accessed from common web browsers.
    - **Aruba AirWave:** A powerful and easy-to-use network operations system that manages wired and wireless infrastructures. For more information, visit <https://www.arubanetworks.com/products/networking/management/airwave>.
    - **Aruba Activate:** Cloud-based service that provides inventory control and facilitates Zero Touch Provisioning. (Available in future Aruba Activate release)
    - **Aruba ClearPass Policy Manager:** Network policy management software for wired and wireless network devices that provide on-boarding and role-based control/security.
    - **Aruba Central:** Network management software cloud platform. It offers IT organizations a simple, secure, and cost-effective way to manage and monitor Aruba switches and Aruba instant wireless APs. (Available in future Aruba Central release)
  - Support for the Spanning Tree Protocol to eliminate network loops.
  - Support for up to 512 IEEE 802.1Q-compliant VLANs so you can divide the attached end nodes into logical groupings that fit your business needs.
  - Support for many advanced features to enhance network performance: For a description, see the AOS-CX guides for your switch.
  - Ability to update the switch software. To download product updates, go to the Aruba Support Portal.
  - An auxiliary port (USB Type-A connector) for updating switch software.
-

The following sections shows how to install the switch. The switches come with an accessory kit that includes the brackets for mounting the switch in a standard 19-inch Telco rack or in an equipment cabinet. Also included are rubber feet that can be attached so the switch can be securely positioned on a horizontal surface. The brackets are designed to allow mounting the switch in a variety of locations and orientations. For other mounting options, contact your local Hewlett Packard Enterprise authorized network reseller or Hewlett Packard Enterprise representative.

### Shipping the switch in a rack

If the switch is to be shipped in a rack, it can be mounted and shipped in a Hewlett Packard Enterprise Universal Rack.



---

All models except JL679A, R8N89A, S4R22A, S4R23A, S4R28A, and S4R29A may be shipped in a rack.

---

- This method uses the HPE X410 Universal Rack Mounting Kit (J9583A, J9583B).
- To order the J9583A or J9583B rack mounting kit, contact your Aruba sales representative.

### Included parts

The switches have the following components shipped with them:

- Documentation kit
- Accessory kit containing:

Model	Accessory Kit Part Number	Items
JL675A / R8N85A / R9Y03A / R9Y04A / R9Y03B / R8N85B/ S4R20A / S4R24A	5300-1364	<ol style="list-style-type: none"> <li>1. Cable tie (1)</li> <li>2. Holder (2)</li> <li>3. Rubber pad 12s12x4mm (4)</li> <li>4. Screw kit (1)</li> </ol>
JL676A / R8N86A / R8N86B / S4R25A	5300-1365	<ol style="list-style-type: none"> <li>1. Cable tie (1)</li> <li>2. Holder (2)</li> <li>3. Rubber pad 12x12x4mm (4)</li> <li>4. Screw kit (1)</li> </ol>

Model	Accessory Kit Part Number	Items
JL677A / R8N87A / R8N87B / S4R26A	5300-1364	<ol style="list-style-type: none"> <li>1. Cable tie (1)</li> <li>2. Holder (2)</li> <li>3. Rubber pad 12x12x4mm (4)</li> <li>4. Screw kit (1)</li> </ol>
JL678A / R8N88A / R8N88B / S4R27A	5300-1365	<ol style="list-style-type: none"> <li>1. Cable tie (1)</li> <li>2. Holder (2)</li> <li>3. Rubber pad 12x12x4mm (4)</li> <li>4. Screw kit (1)</li> </ol>
JL679A / R8N89A / R8N89B / S4R21A	5300-1028	<ol style="list-style-type: none"> <li>1. 5300-1026 (Mounting kit - wall short) <ol style="list-style-type: none"> <li>a. Screw kit (1)</li> <li>b. Short mounting bracket (2)</li> </ol> </li> <li>2. 5380-0418 <ol style="list-style-type: none"> <li>a. Long mounting bracket (2)</li> </ol> </li> </ol>
S4R22A / S4R28A	5300-3136	<ol style="list-style-type: none"> <li>1. Mounting bracket (2)</li> <li>2. Rubber pad 12x12x9.5mm (4)</li> <li>3. Screw kit (1)</li> </ol>
S4R23A / S4R29A	5300-3167	<ol style="list-style-type: none"> <li>1. Mounting bracket (2)</li> <li>2. Rubber pad 12x12x9.5mm (4)</li> <li>3. Screw kit (1)</li> </ol>
JL742A	5300-1375	<ol style="list-style-type: none"> <li>1. Screw kit (1)</li> </ol>



The existing JL742A (cable guard) does not support the 8P PoE switches (S4R22A, S4R23A, S4R28A, and S4R29A).



The switch has a USB-C port used to manage the switch. Any compatible USB cable certified for data transfer can be used as a console cable.

- Power cord (not for JL742A), one of the following:

North America	8121-1141	Australia	8121-0837
Taiwan	8121-0964	Brazil	8121-1071
India	8121-0564	Europe/South Korea	8121-0731
Israel	8121-1004	China	8121-0943

United Kingdom/Hong Kong/Singapore/Malaysia	8121-0739	Argentina	8121-0729
Switzerland	8121-0738	Chile	8121-0735
Denmark	8121-0733	Thailand/Philippines	8121-0734
Japan	8121-1143	JmpCbl NA/JP/TW/ROW	142263-001
South Africa	8121-0737	220V NA	8120-3996

---

# Installation procedures for 6000 and 6100 switches

1. Prepare the installation site.
2. Unpack the switch and verify that you have received the correct parts.
3. Connect power to the switch and wait for the health LED to turn green after the switch passes the self-test, then remove power from the switch.
4. Mount the switch.



---

Mounting restrictions apply. See the warnings under [Installation precautions and guidelines](#).

---

5. Connect the switch to a power source.
6. (Optional) Install transceivers.
7. Connect the network cables.
8. Configure the switch for network operation.

## Installation precautions and guidelines

To avoid personal injury or product damage when installing your switch, read the following installation precautions and guidelines.



- 
- Mount devices installed in a rack or cabinet as low as possible. Put the heaviest devices at the bottom and progressively lighter devices positioned higher.
  - To prevent the rack or cabinet from becoming unstable and/or falling over, ensure that it is secured.
- 



- 
- If your installation needs a different power cord than the one provided, ensure that the cord is sized for the switch requirements. In addition, use a power cord marked by the safety agency that regulates the power cords in your country/region. The mark is assurance that the power cord can be used safely.
  - Ensure that the power source circuits are properly grounded. Then connect the switch to the power source by using the power cord supplied with the switch.
  - When installing the switch, ensure that the AC outlet is near the switch. Make it easily accessible in case the switch must be powered off.
  - Ensure the power cord and network cables at the switch mounting location do not create a tripping hazard.
  - Do not install the switch in an environment where the operating temperature exceeds its specification.
  - Ensure that the switch does not overload the power circuits, wiring, and over-current protection at your installation site. To determine the possibility of overloading the supply circuits, add the ampere ratings of all devices installed on the same circuit as the switch. Then compare the total with the rating limit for the circuit. The maximum ampere ratings are printed on the devices near the AC power connectors.
  - Ensure that the air flow around the switch is not restricted. Leave at least 3 inches (7.6 cm) for cooling.
-

## Prepare the installation site

**Cabling Infrastructure:** Ensure the cabling infrastructure meets the necessary network specifications. See [Cabling and technology information](#) for more information.

**Installation Location:** Before installing the switch, plan its location and orientation relative to other devices and equipment:

- In the front or the back of the switch, leave at least 7.6 cm (3 inches) of space for the twisted-pair and fiber-optic cabling.
- In the back of the switch, leave at least 7.6 cm (3 inches) of space for the power cord.
- On the sides of the switch, leave at least 7.6 cm (3 inches) for cooling, except if the switch is installed in an open EIA/TIA rack.

*Air flow direction of the switches*

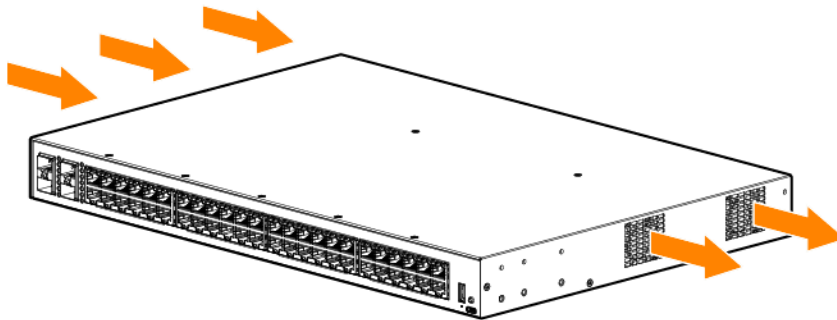

## Verify that the switch boots correctly

Before installing the switch in its network location, plug it into a power source and verify that it boots correctly.

1. Connect the power cord supplied with the switch to the power connector on the back of the switch. Then plug the power cord into a properly grounded electrical outlet.



- 
- The switches do not have a power switch. They are powered on when the power cord is connected to the switch and to a power source. For safety, locate the power outlet near the switch installation.
  - If your installation requires a different power cord than the one supplied with the switch, be sure to use a power cord displaying the mark of the safety agency that defines the regulations for power cords in your country/region. The mark is your assurance that the power cord can be used safely with the switch.
- 

2. Check the LEDs on the switch to make sure the switch is on and operating.

When the switch is powered on, it performs its diagnostic self-test and initialization. This boot process, depending on switch model and configuration, takes approximately 1-2 minutes to complete.

## Disconnect power from the switch

Disconnect the power cord from the switch and from the power source.

*8P switches power cord*

---

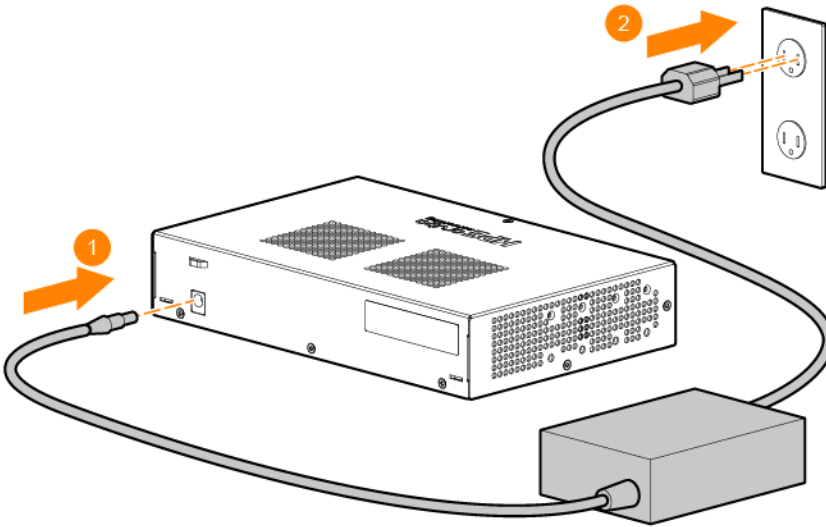

## Mount the switch



Unplug the AC power from the switch before mounting it.

The switches can be mounted in these ways:

SKU	Mounting options
HPE Aruba Networking 6000 48G Class4 PoE 4SFP 740W Switch (R9Y03A)	Rack/cabinet or horizontal surface
HPE Aruba Networking 6000 48G Class4 PoE 4SFP 370W Switch (R8N85A)	Rack/cabinet or horizontal surface
HPE Aruba Networking 6000 48G 4SFP Switch (R8N86A)	Rack/cabinet or horizontal surface
HPE Aruba Networking 6000 24G Class4 PoE 4SFP Switch (R8N87A)	Rack/cabinet or horizontal surface
HPE Aruba Networking 6000 24G 4SFP Switch (R8N88A)	Rack/cabinet or horizontal surface
HPE Aruba Networking 6000 12G Class4 2SFP 139W Switch (R8N89A)	Rack/cabinet, horizontal surface, wall, or under table
HPE Aruba Networking 6000 48G Class4 PoE 4SFP 1G 740W Switch (R9Y03B)	Rack/cabinet or horizontal surface
HPE Aruba Networking 6000 48G Class4 PoE 4SFP 1G 370W Switch (R8N85B)	Rack/cabinet or horizontal surface
HPE Aruba Networking 6000 48G 4SFP 1G Switch (R8N86B)	Rack/cabinet or horizontal surface

SKU	Mounting options
HPE Aruba Networking 6000 24G Class4 PoE 4SFP 1G 370W Switch (R8N87B)	Rack/cabinet or horizontal surface
HPE Aruba Networking 6000 24G 4SFP 1G Switch (R8N88B)	Rack/cabinet or horizontal surface
HPE Aruba Networking 6000 12G Class4 PoE 2SFP 1G 139W Switch (R8N89B)	Rack/cabinet, horizontal surface, wall, or under table
HPE Aruba Networking 6000 8G 2SFP 1G Switch (S4R22A)	Rack/cabinet or horizontal surface
HPE Aruba Networking 6000 8G Class4 PoE 2SFP 1G 67W Switch (S4R23A)	Rack/cabinet or horizontal surface
HPE Aruba Networking 6000 48G Class4 PoE 4SFP 1G 740W TAA Switch (S4R20A)	Rack/cabinet or horizontal surface
HPE Aruba Networking 6000 12G Class4 PoE 2SFP 1G 139W TAA Switch (S4R21A)	Rack/cabinet, horizontal surface, wall, or under table
HPE Aruba Networking 6000 48G Class4 PoE 4SFP 1G 370W TAA Switch (S4R24A)	Rack/cabinet or horizontal surface
HPE Aruba Networking 6000 48G 4SFP 1G TAA Switch (S4R25A)	Rack/cabinet or horizontal surface
HPE Aruba Networking 6000 24G Class4 PoE 4SFP 1G 370W TAA Switch (S4R26A)	Rack/cabinet or horizontal surface
HPE Aruba Networking 6000 24G 4SFP 1G TAA Switch (S4R27A)	Rack/cabinet or horizontal surface
HPE Aruba Networking 6000 8G 2SFP 1G TAA Switch (S4R28A)	Rack/cabinet or horizontal surface
HPE Aruba Networking 6000 8G Class4 PoE 2SFP 1G 67W TAA (S4R29A)	Rack/cabinet or horizontal surface

SKU	Mounting options
HPE Aruba Networking 6100 48G Class4 PoE 4SFP+ 740W Switch (R9Y04A)	Rack/cabinet or horizontal surface
HPE Aruba Networking 6100 48G CL4 4SFP+ Swch (JL675A)	Rack/cabinet or horizontal surface
HPE Aruba Networking 6100 48G 4SFP+ Swch (JL676A)	Rack/cabinet or horizontal surface
HPE Aruba Networking 6100 24G CL4 4SFP+ Swch (JL677A)	Rack/cabinet or horizontal surface
HPE Aruba Networking 6100 24G 4SFP+ Swch (JL678A)	Rack/cabinet or horizontal surface
HPE Aruba Networking 6100 12G CL4 2SFP+ 139W Swch (JL679A)	Rack/cabinet, horizontal surface, wall, or under table

- If you are mounting an 8G switch (S4R22A, S4R23A, S4R28A, or S4R29A) or 12G switch (JL679A, R8N89A, R8N89B, or S4R21A) in a rack with other products, the preferred position for the switch is at the base of the rack (for optimal cooling), or underneath as many of the other products as can be accommodated.
- When mounted in a rack, the best practice is to ensure that a 2U (88.9 mm / 3.5 inch) vertical space is left between the switch and the device above it. Minimally, a 76.2 mm / 3 inch space is required.
- When mounting the switches on a wall or on a horizontal surface, ensure that the supplied four rubber mounting feet are placed on the bottom of the switch. This provision is required to provide the proper thermal spacing between the switch and the mounting surface.
- Avoid obstructing the ventilation holes on the top, sides, front, and back of the switch.
- Do not install the switches in a confined space that prevents a free air flow.
- When installing the switch in an enclosed space containing free air flow, ensure that any adjacent surfaces are at least 15.3 cm (6 inches) from the top, sides, and back of the switch.



---

Mounting HPE Aruba Networking 6000 and 6100 12G switches with ports facing upward is not supported.

---



---

Physically stacking any switch model on top of an 8G or 12G switch can interrupt the flow of warm air through the vents in the top of the 12G switch and is not supported.

---

## Rack or cabinet mounting

All switches can be mounted in a rack. The switches are designed to be mounted in any EIA-standard 19-inch Telco rack or communication equipment cabinet.

The 24-port and 48-port switches can also be mounted in 4-post racks and cabinets by using the X410 Switch Rail Kit (J9583A). For instructions on using the kit, see the documentation included with the kit.



---

If a 24-port or 48-port switch is to be shipped in a rack, it can be mounted and shipped in a Hewlett Packard Enterprise 10K rack using the HPE X410 Universal Rack Mounting Kit (J9583A). Additionally, it can also be mounted in any four post rack using the HPE X410 Universal Rack Mounting Kit (J9583A).

---

Some mounting brackets have multiple mounting holes and can be rotated, allowing for a wide variety of mounting options. Secure the rack in accordance with the manufacture's safety guidelines.



---

For safe operation, please read [Installation precautions and guidelines](#) before mounting the switch.

---



---

The screws supplied with the switch are the correct threading for standard EIA/TIA open 19-inch racks. If you are installing the switch in an equipment cabinet such as a server cabinet, use the clips and screws that came with the cabinet in place of the screws that are supplied with the switch.

---

Complete the following step 1 to attach brackets to the switch. Then, plan which four holes you will be using in the cabinet and install all four clips. Then proceed to step 2 to install the switch in the cabinet.

---

## 24-port and 48-port switches

1. Use a #1 Phillips (cross-head) screwdriver and attach the mounting brackets to the switch with the included 6-mm M4 screws.

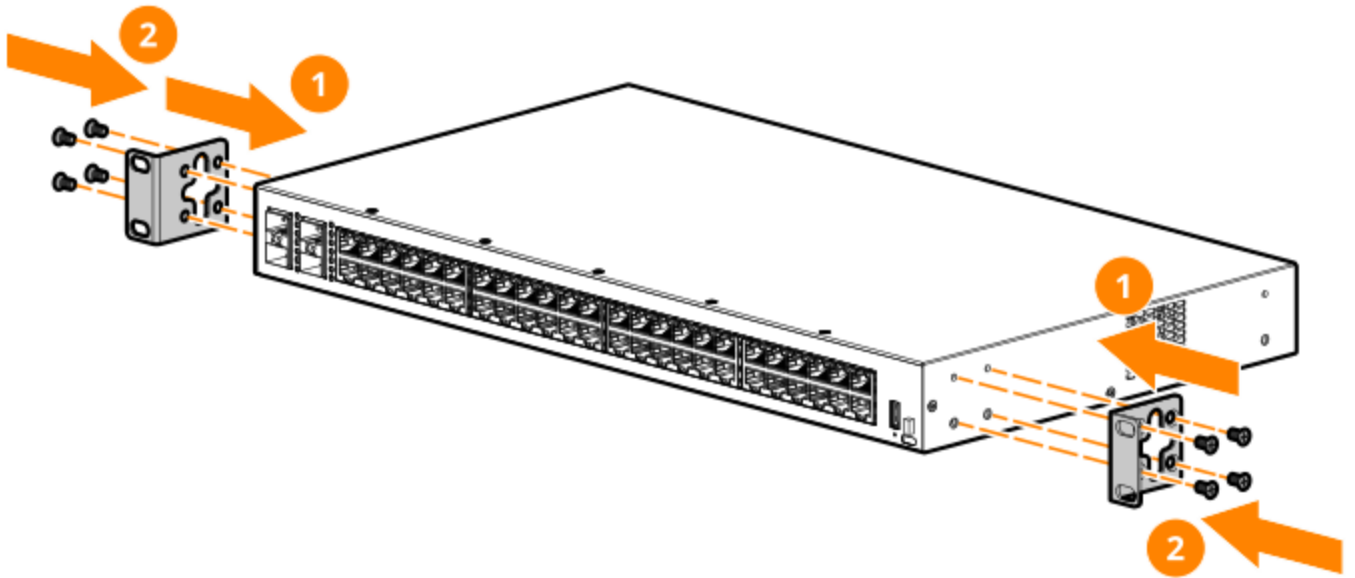

For safe reliable installation, only use the screws provided in the accessory kit to attach the mounting brackets to the switch.

2. Hold the switch with attached brackets up to the rack and move it vertically until rack holes line up with the bracket holes, then insert and tighten the four number 12-24 screws holding the brackets to the rack.

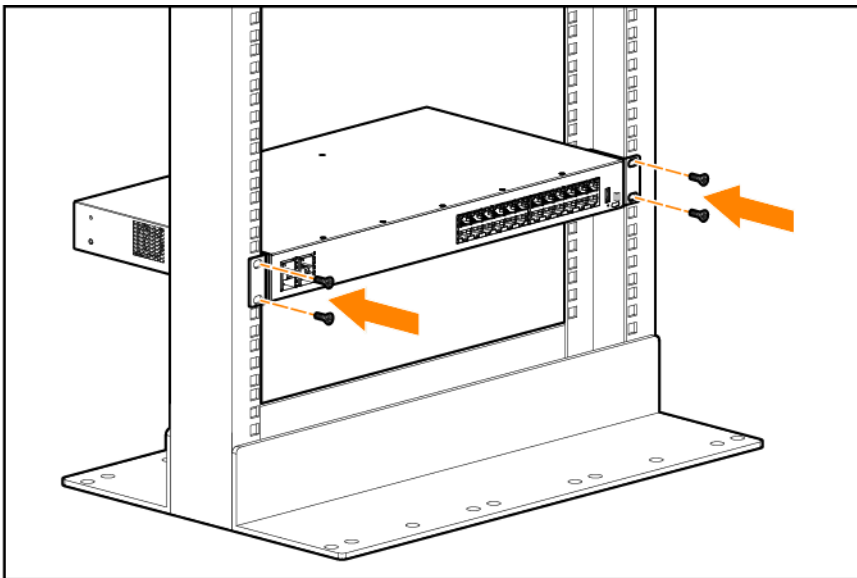

## 8-port and 12-port switches

1. Attach the long rack mounting brackets to the switch with the included 6-mm M4 screws. You can orient the brackets to be flush or offset with the switch front panel (as shown in the following illustrations). Mounting brackets can also be attached at the middle of the switch.

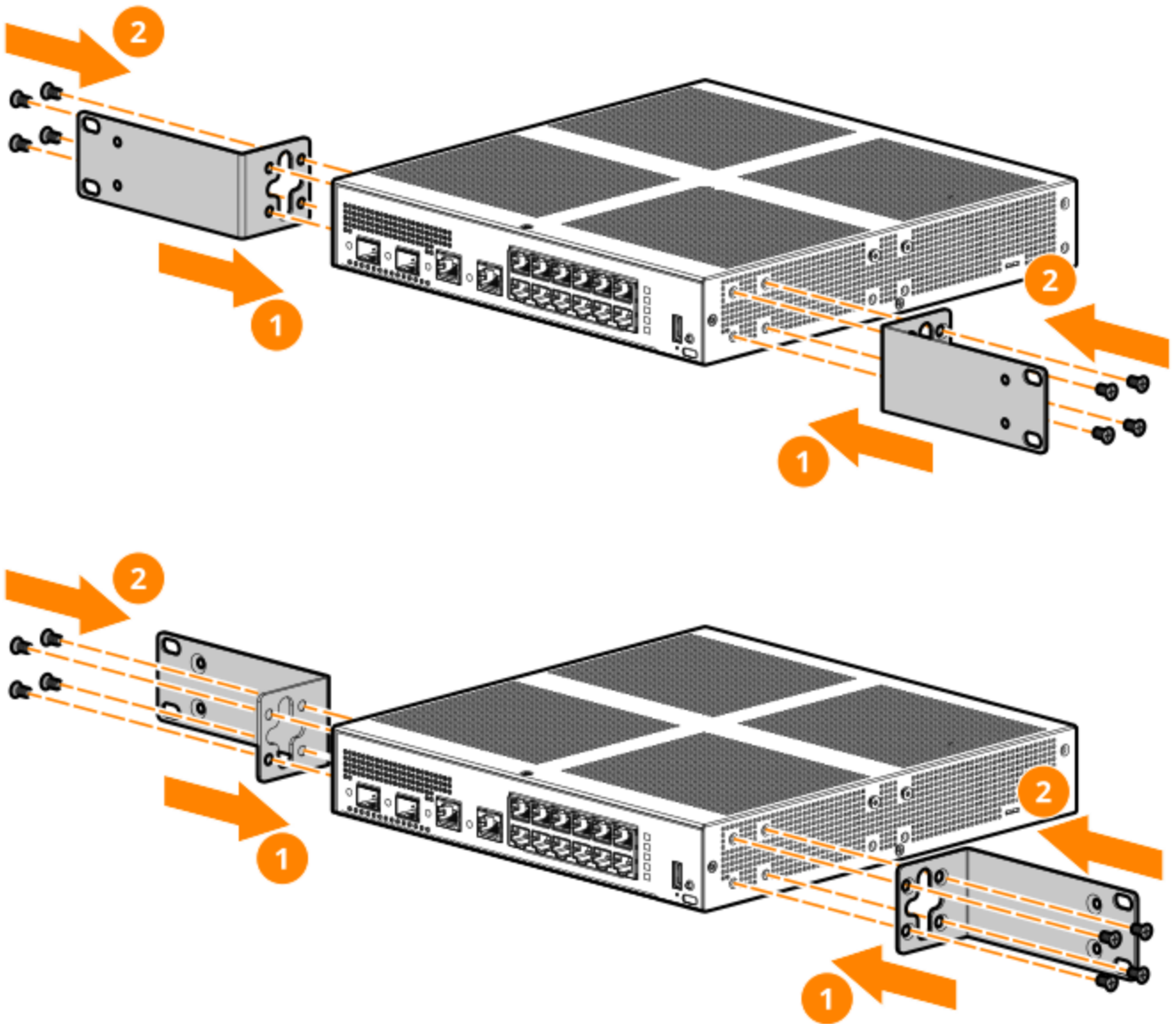

---

For safe reliable installation, only use the screws provided in the accessory kit to attach the mounting brackets to the switch.

---

2. Secure the rack mounting brackets to a two-post rack as shown in the following illustrations.  
*Flush Mounting in a two-post rack*

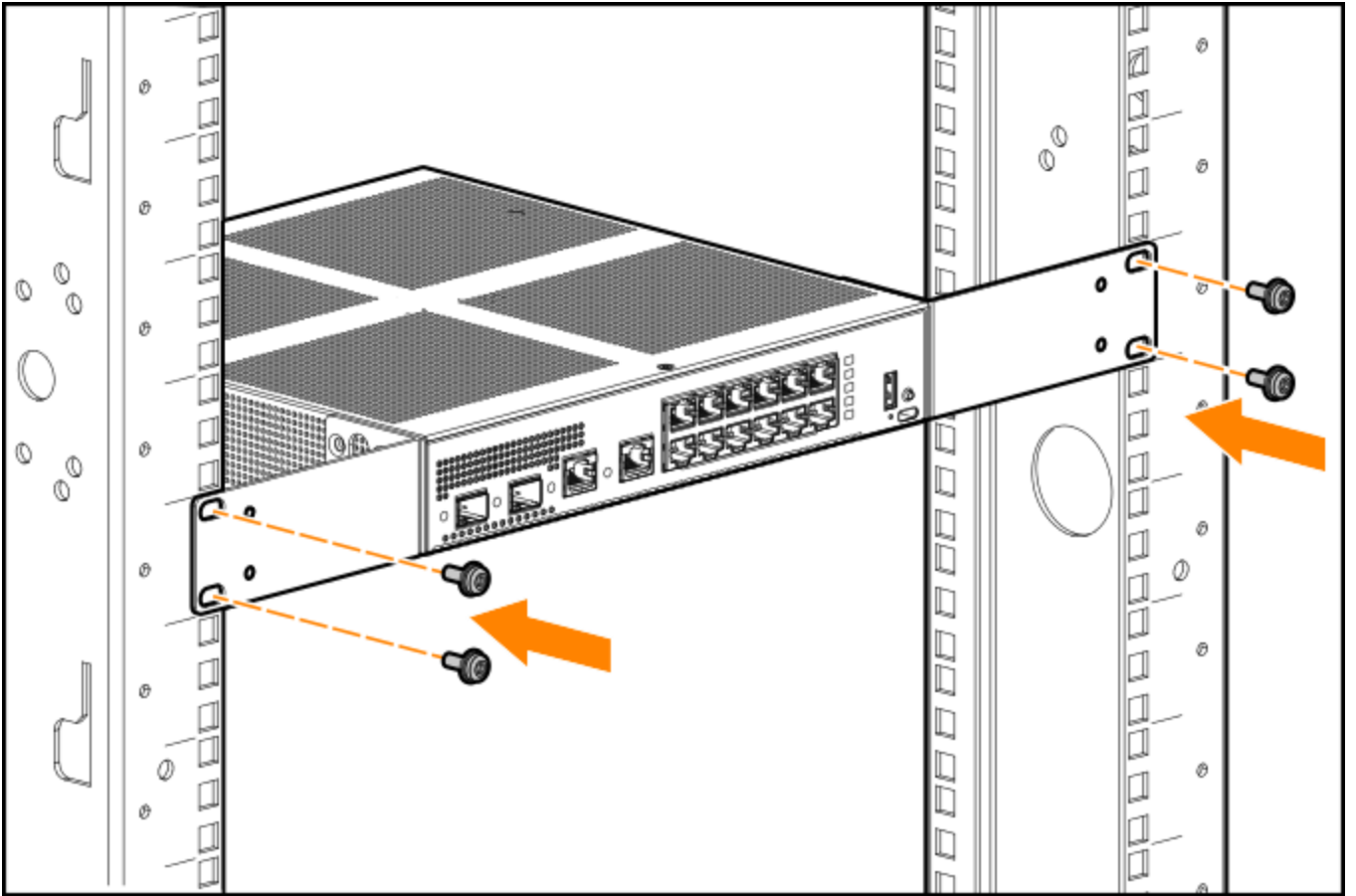

*Mounting in a two-post rack at switch middle*

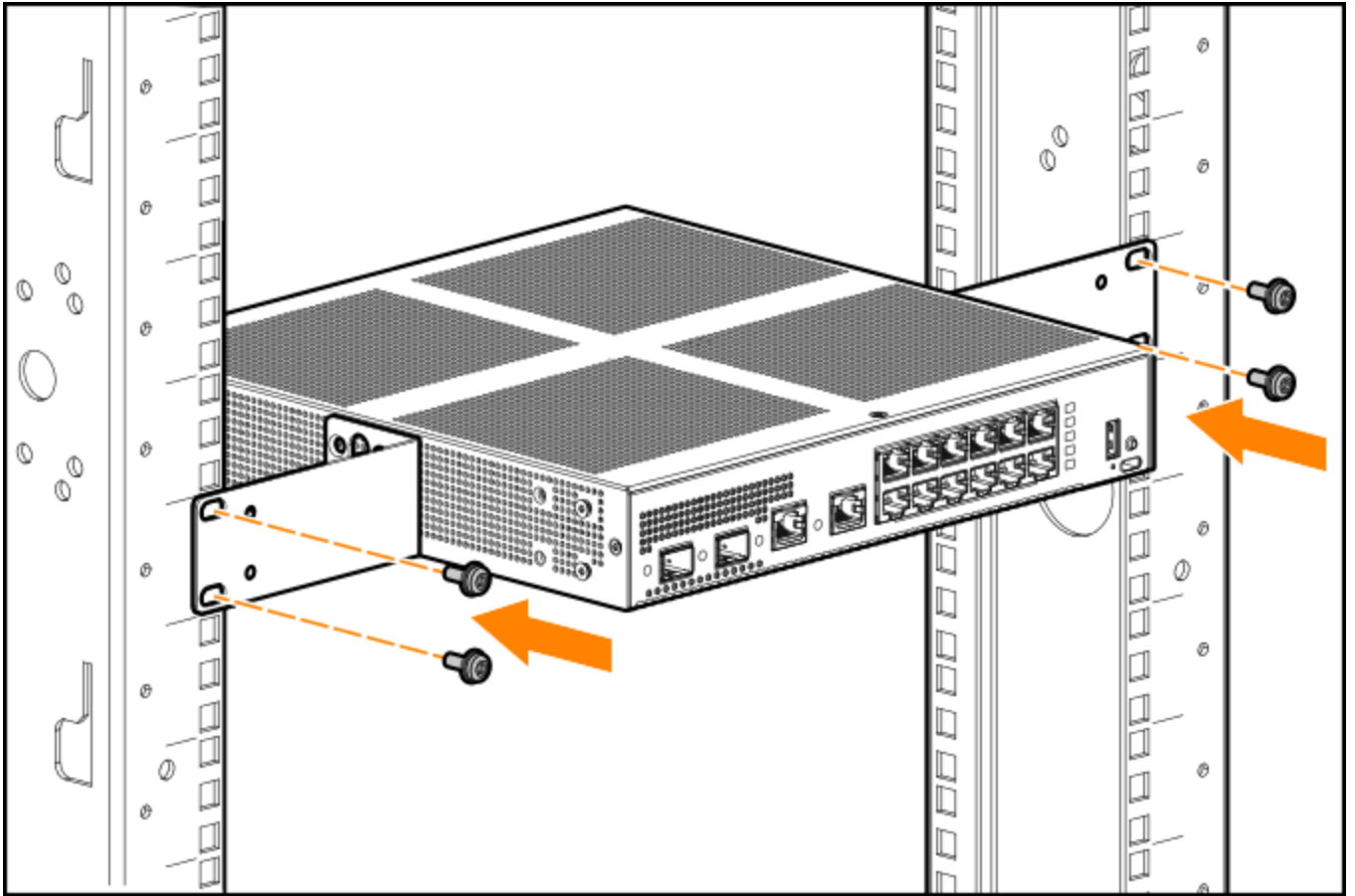

## Horizontal surface mounting

1. Place the switch on a table or other horizontal surface. The switch comes with rubber feet in the accessory kit that can be used to help keep the switch from sliding on the surface.
2. Attach the rubber feet to the four corners on the bottom of the switch within the embossed angled lines. Use a sturdy surface in an uncluttered area. You may want to secure the networking cables and switch power cord to the table leg or other part of the surface structure to help prevent tripping over the cords.

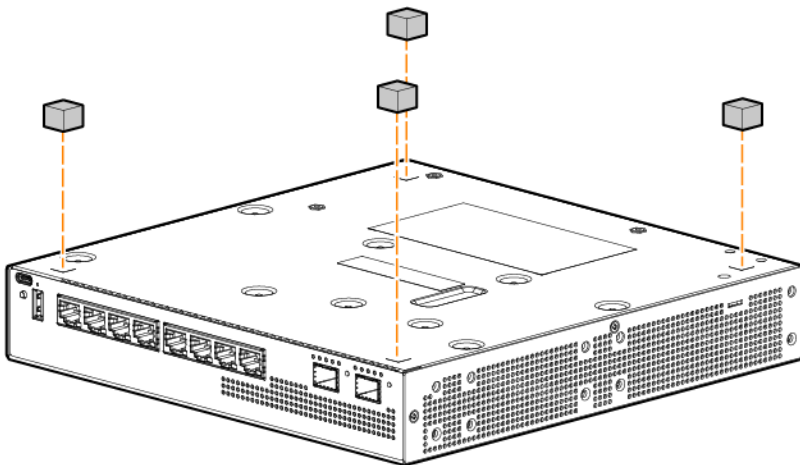

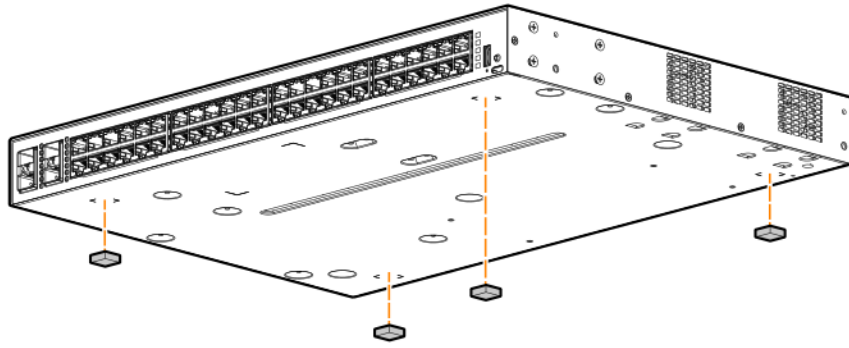

---

Nothing should be placed on top of the switch. Adequate spacing on all sides needs to be maintained for ventilation.

---



---

When mounting the switch on top of a surface, position the switch so that items (papers and other items) are not likely to be put on top of it or next to it, blocking the ventilation holes.

---



---

For fanless models, attaching the four rubber feet to the bottom of the switch is required to provide the necessary thermal transfer space between the switch bottom and the horizontal surface.

---

## Wall mounting 12G switches

### Aruba 6000 and 6100 12G airflow

Aruba 12G switches are fan-less and rely on natural convection to maintain proper operating temperature.



---

Aruba 12G switches (JL679A, R8N89A, R8N89B, and S4R21A) can only be mounted with ports facing left, right or downward.

---



---

Mounting the switch with ports facing upward is not supported.

---

Ports facing left

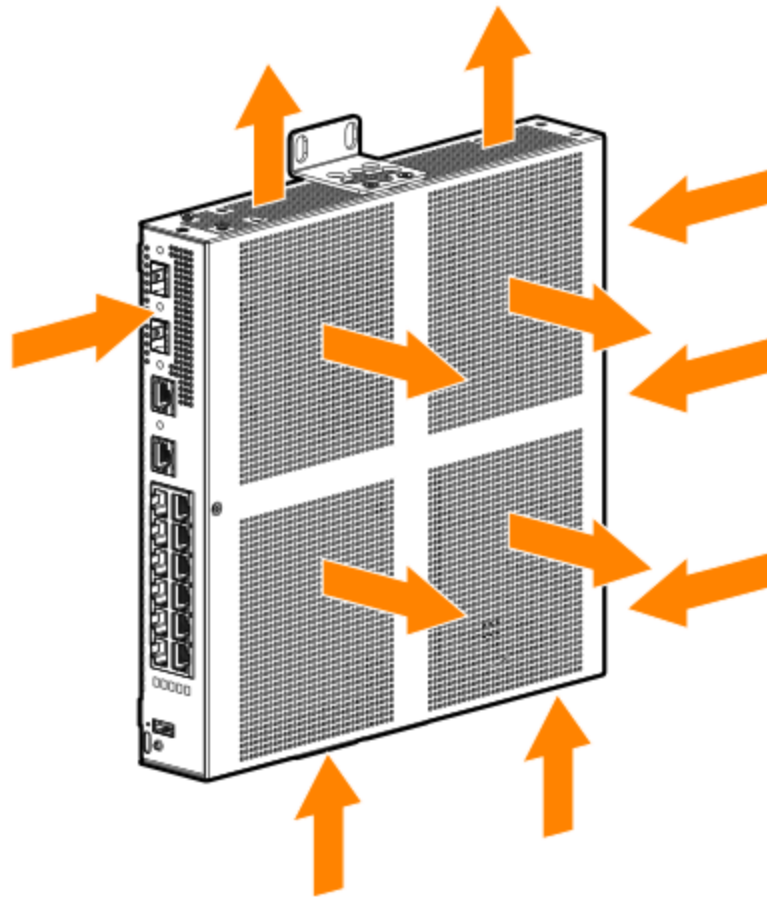

*Ports facing right*

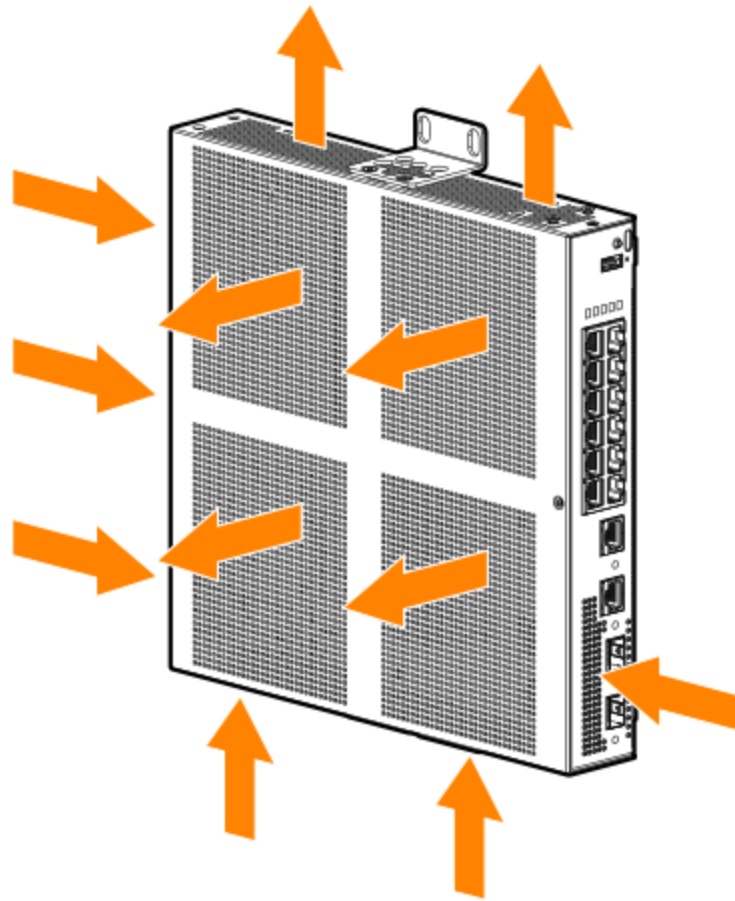

Ports facing downward

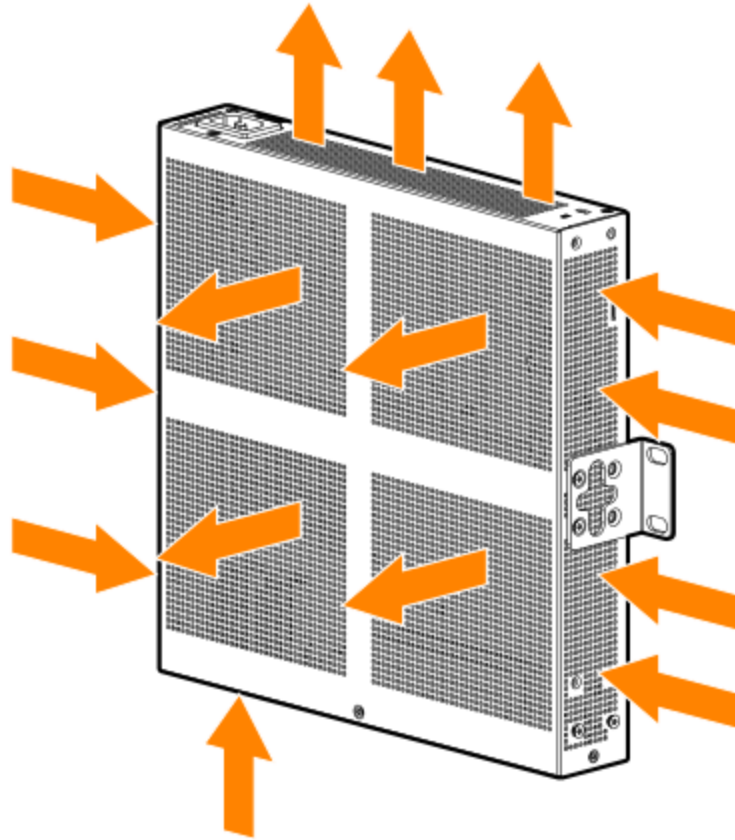

## Mounting

You can mount the 12G switches on a wall with the front panel facing down, left, or right only. The switch ships with a wall mounting bracket to support a more robust wall mount.

The switch is designed to support mounting in a 12-inch (304.8 cm)-wide enclosure with a top and bottom air opening. Natural convection with at least a 40 LFM air flow is required in this configuration.



---

For safe operation, please read [Installation precautions and guidelines](#) before mounting the switch.

Wall mount the switch with the network ports facing down, left, or right. Do not mount with the network ports facing up.

---



---

The switch should be mounted only to a wall or wood surface that is at least 1/2-inch (12.7 mm) plywood or its equivalent.

---

You can mount the switch using either the mounting brackets or the mounting holes provided on the bottom of the switch.

## Mounting brackets

To mount the 12G switch to the wall using the mounting brackets, follow these steps:

1. Determine and mark screw hole locations by positioning the switch where it will be installed.
2. Drill four holes in the wall to receive the four bracket screws.
3. Use a #1 Phillips (cross-head) screwdriver and attach the mounting brackets to the switch with the included 6-mm M4 screws.
4. Mount the switch to the wall using four screws (not included), applicable for the type of wall being used.

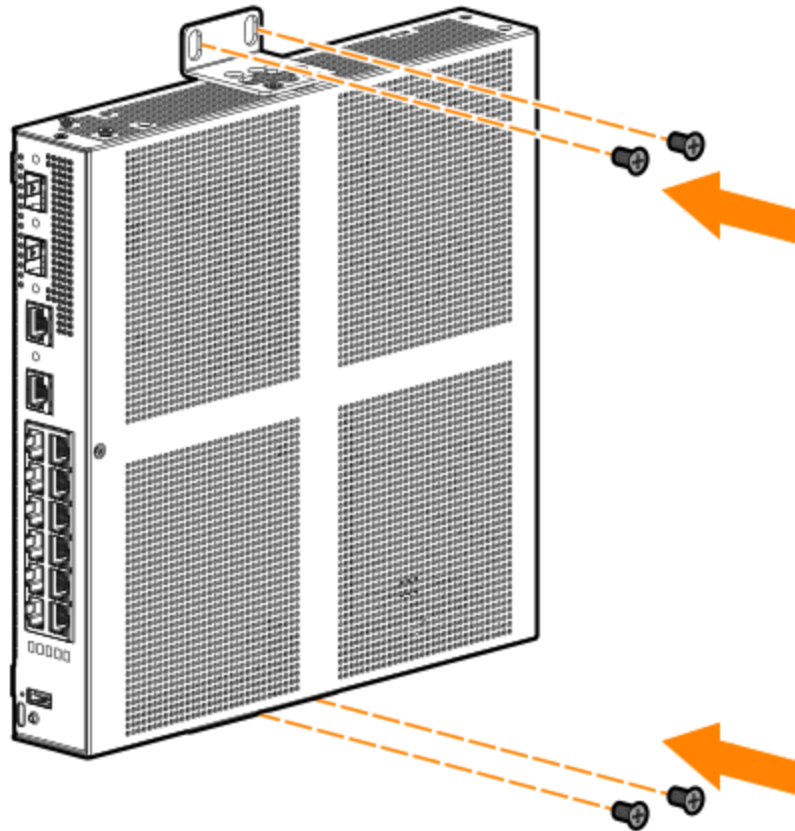

## Mounting holes

To mount the 12G switch using the holes located on the bottom of the switch, follow these steps:

1. In the required location, mark the position for the mounting screws. The hole-to-hole distance is 7 inch (178 mm) (x-axis) and 5.8 inch (147 mm) (y-axis).
2. Use two screws with heads sized correctly for the mounting holes and with sufficient strength to hold the switch to the wall. Set the screw heads approximately 2 mm away from the mounting

surface to allow the switch to slide onto the screws.

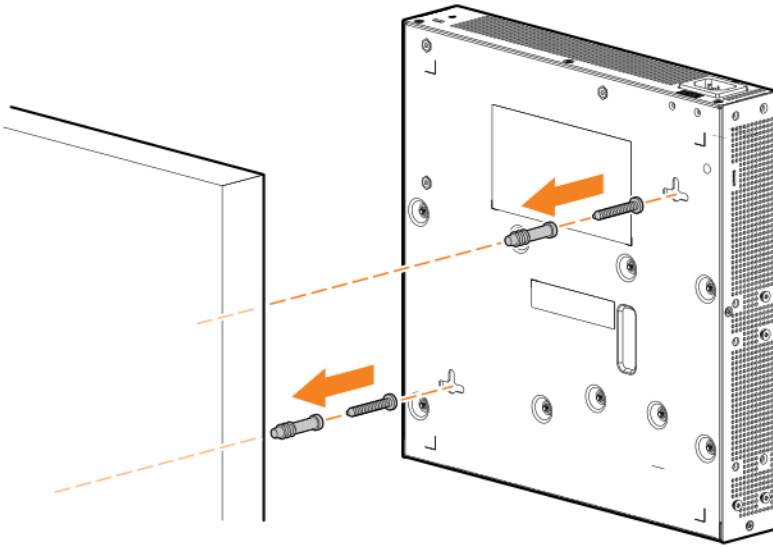

### Under-table mounting for 12G switch



- Position the switch with its top up. Inverting the switch (top vents facing downward) in an under-table mounting, reduces ventilation from inside the switch and is not supported.
- The switch must be secured using the long rack mount brackets (included) that provide a 3" (76.2 mm) gap between the top of the switch and the underside of the table top.

1. Attach the long (rack/table) mounting brackets to the switch.
2. Secure the rack/table mounting brackets to the underside of table/horizontal surface.

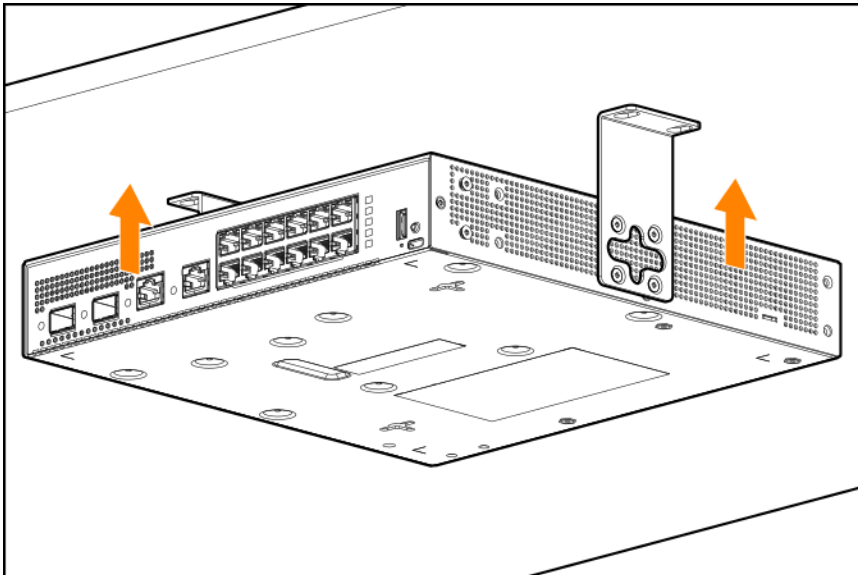

## Connect the switch to a power source

1. Plug the included power cord into the power connector on the switch and into a nearby AC power source.
2. Recheck the LEDs during self-test.

## (Optional) Install transceivers

You can install or remove transceivers from the slots on the front of the switch without having to power off the switch.



---

The transceivers operate only at full duplex. Half duplex operation is not supported.

Ensure that the network cable is NOT connected when you install or remove a transceiver.

---

(Optional) Insert up to four SFP or SFP+ transceivers in the fixed transceiver slots on the switch front panel.

## Connect network cables

Connect network cables from network devices or your patch panels to the fixed RJ-45 ports and to any installed transceivers.

## SFP Installation Notes



---

When selecting a fiber SFP device, make sure it can function at a maximum temperature that is not less than the recommended maximum operational temperature of the product. Use only an approved Laser Class 1 SFP transceiver.

---



---

To ensure proper operation of your switch, use only the HPE Aruba SFP transceivers supported by your switch.

---

**Use only supported HPE Aruba SFP transceivers.** Non-HPE Aruba SFP transceivers are not supported. Use of supported HPE Aruba products ensures that your network maintains optimal performance and reliability. If you require additional transceivers, contact an HPE Aruba sales representative or an authorized reseller. The following resources can help you to find transceiver support information for your switch model:

- See the *Transceiver Guide*.
- See the supported transceivers information in the QuickSpecs for your switch model, along with minimum software versions to support the listed transceivers.

**Hot Swapping SFP transceivers.** Supported SFP transceivers that you can install in your Hewlett Packard Enterprise OfficeConnect switch can be "hot swapped". "Hot swapping" means supported transceivers can be removed and installed while the switch is receiving power. Disconnect the network cables from the SFP transceivers before hot-swapping them.

When you replace an SFP transceiver with another of a different type, the switch may retain selected port-specific configuration settings that were configured for the replaced unit. Be sure to validate or reconfigure port settings as required.

---

**SFP Connections to Devices with Fixed Speed/Duplex Configurations.** When connecting a device to your switch port that contains an SFP transceiver, the speed and duplex settings of the switch port and the connected device must match. If the settings do not match, the device may not link properly—you may not get a link. For some older network devices, including some older Hewlett Packard Enterprise devices, the default speed/duplex settings may be predefined. (For example, a setting might be 1000 Mbps/Full Duplex.) There may also be other settings that differ from the default configuration of your switch port. Because of these default speed/duplex considerations, make sure that devices connected to your SFP ports are properly configured. At a minimum, make sure the configurations match.

## SFP+ installation notes (6100 switch series only)



---

When selecting a fiber SFP+ device, make sure it can function at a maximum temperature that is not less than the recommended maximum operational temperature of the product. Use only an approved Laser Class 1 SFP+ transceiver.

---

To ensure proper operation of your switch, use only the Aruba SFP+ transceivers supported by your switch.

Non-Aruba SFP+ transceivers are not supported. Use of supported Aruba products ensures that your network maintains optimal performance and reliability. If you require additional transceivers, contact an Aruba sales representative or an authorized reseller. The following resources can help you to find transceiver support information for your switch model:



- See the *Transceiver Guide*.
  - See the supported transceivers information in the data sheet for your switch model.
- 

### Hot swapping SFP+ transceivers

Supported SFP+ transceivers that you can install in your Aruba switch can be "hot swapped"—removed and installed while the switch is receiving power. However, disconnect the network cables from the SFP+ transceivers before hot-swapping them.

When you replace a SFP+ transceiver with another transceiver of a different type, the switch may retain selected port-specific configuration settings that were configured for the replaced unit. Be sure to validate or reconfigure port settings as required.

### SFP+ connections to devices with fixed speed/duplex configurations

When connecting a device to your switch port that contains a SFP+ transceiver, the speed and duplex settings of the switch port and the connected device must match. Otherwise, the device may not link properly—you may not get a link. For some older network devices, the default speed/duplex settings may be predefined such that they are set differently from the default configuration of your switch. (For example, 1000 Mbps/Full Duplex.) These setting differences may also apply to some older Hewlett Packard Enterprise devices. Because of these default speed/duplex considerations, make sure that devices connected to your SFP+ ports are properly configured. At a minimum, make sure the configurations match.

This chapter is a guide for using the console Switch Setup screen to quickly assign an IP address and subnet mask to the switch. You can also set a Manager password and, optionally, configure other basic features.

For more information on using the switch console, see the *Fundamentals Guide* for your switch model.

## Recommended minimal configuration

In the factory default configuration, the switch has no IP address and subnet mask, and no passwords. In this state, it can be managed only through a direct console connection. To manage the switch through in-band (networked) access, configure the switch with an IP address and subnet mask compatible with your network. See the *Fundamentals Guide* for your switch for more information on the various methods that can be used for initial configuration.

Also, configure a Manager password to control access privileges from the console and web browser interface. Other parameters in the Switch Setup screen can be left at either their default settings or settings you manually enter.

Many other features can be configured through the switch console interface to optimize performance, to enhance your control of the network traffic, and to improve network security. Once an IP address has been configured on the switch, these features can be accessed more conveniently through a remote Telnet session, through the switch web browser interface, and from an SNMP network management station running a network management program. For a list of switch features available with and without an IP address, see the latest version of the *Fundamentals Guide* for your switch.

This chapter describes how to troubleshoot your switch, primarily from a hardware perspective. You can perform more in-depth troubleshooting on the switch using the software tools available with the switch. Included are the console interface and the built-in web browser interface.

## Basic troubleshooting tips

Most problems are caused by the following situations. Check for these items first when starting your troubleshooting:

- **Connecting to devices that have a fixed full-duplex configuration:** The RJ-45 ports are configured as "Auto". That is, when connecting to attached devices, the switch uses auto-negotiation to determine the link speed and the communication mode:
  - If the connected device is also configured to Auto, the switch will automatically negotiate both link speed and communication mode.
  - If the connected device has a fixed configuration, at 10Mbps or 100Mbps, at half or full duplex, the switch will automatically sense the link speed, but will default to a communication mode of half duplex.

Because the switch behaves in this way (in compliance with the IEEE 802.3 standard), if a device connected to the switch has a fixed configuration at full duplex, the device will not connect correctly to the switch. The result will be high error rates and inefficient communications between the switch and the device.

Make sure that all the devices connected to the switch are configured to auto negotiate, or are configured to speed and duplex settings matching the settings configured on the corresponding switch port.

- **Improper network topologies:** It is important to make sure that you have a valid network topology. Common topology faults include excessive cable length and excessive repeater delays between end nodes. If you have network problems after recent changes to the network, change back to the previous topology. If you no longer experience the problems, the new topology is probably at fault.

In addition, make sure that your network topology contains no datapath loops. Between any two end nodes, only one active cabling path is allowed at any time. Data path loops can cause broadcast storms that will severely impact your network performance.

For your switch, if you want to build redundant paths between important nodes in your network to provide some fault tolerance, enable Spanning Tree Protocol support on the switch. This support ensures that only one of the redundant paths is active at any time, thus avoiding datapath loops. For more information on Spanning Tree, see the *Layer 2 Bridging Guide*.

- **Faulty or loose cables:** Look for loose or faulty connections. If they appear to be OK, make sure that the connections are snug. If that does not correct the problem, try a different cable.
- **Nonstandard cables:** Nonstandard and incorrectly wired cables may cause network collisions and other network problems, and can seriously impair network performance. A Category 5 or greater cable tester is a recommended tool for every network installation.
- **Check the port configuration:** A port on your switch may not be operating as expected because it is administratively disabled in the configuration. It may also be placed into a "blocking" state by a

protocol operating on the port (dynamic VLANs), or LACP (dynamic trunking). For example, the normal operation of the spanning tree, MVRP, LACP, and other features may put the port in a blocking state.

Use the switch console to determine the port configuration and verify that there is not an improper or undesired configuration of any of the switch features that may be affecting the port.

## Diagnosing with the LEDs

*Switch and port LEDs*

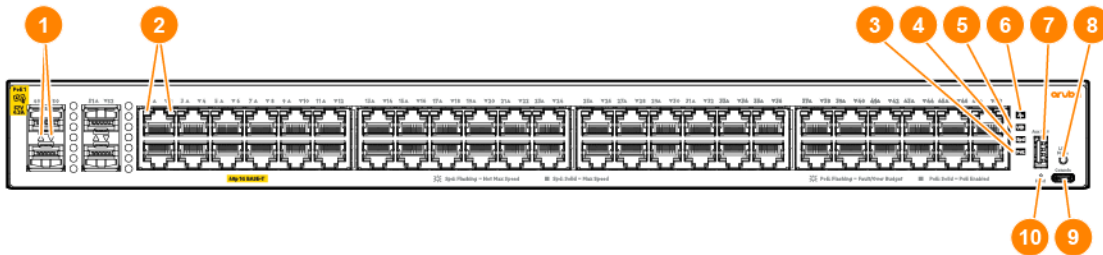

**Table 1:** *Front of all 6000 switches: Label and description*

Label	Description
1	Top and bottom SFP port LEDs
2	Top and bottom RJ45 port LEDs
3	PoE mode LED
4	Speed mode LED
5	UID (Unit Identification) LED
6	Global status LED
7	USB-A port
8	LED mode button
9	USB-C console port
10	Reset button

**Table 2:** *Front of all 6100 switches: Label and description*

Label	Description
1	Top and bottom SFP+ port LEDs
2	Top and bottom RJ45 port LEDs
3	PoE mode LED

Label	Description
4	Speed mode LED
5	UID (Unit Identification) LED
6	Global status LED
7	USB-A port
8	LED mode button
9	USB-C console port
10	Reset button

**Table 3:** Front panel LED behavior

Switch LEDs	Function	State		Meaning
SFP/SFP+ port LEDs *  RJ45 port LEDs *	Displays Link/Activity or Mode information for the port	Startup	OFF	AOS-CX: No valid link SVOS: OFF
		Normal	OFF	No valid link
			Half bright - Green	Valid link indication
			Flash full bright - Green	Indicator of traffic activity. The blink time is roughly proportional to the % of full bandwidth utilization of the port.
		Fault	OFF	No fault
			Flash - Amber	Fault
PoE mode LED *	Indicates Port LEDs are showing PoE information (not applicable for non PoE switches)	Off		PoE mode not selected
		On - Green		PoE mode selected
		Slow Flash - Amber		Hardware failure PoE enabled port, PoE mode not selected
		On - Amber		Hardware failure PoE enabled port, PoE mode selected
Port LEDs **	Indicates the number of stacked switches and identifies the Conductor	Flash - Green		Member is the Conductor
		Flash - Orange		Member is rebooting to join the stack or offline due to error condition
		On - Green		Member joined the stack and is operational

Switch LEDs	Function	State	Meaning
Speed mode LED *	Indicates Port LEDs are showing speed information	Off	Speed mode not selected
		On - Green	Speed mode selected
	Indicates stacking status (applicable for 6100 with no "Stk" mode LED)	On - Green	Switch is in stack mode
UID LED	User-configurable LED	Off	User defined the located LED : OFF
		On/Flash - Blue	User defined the locator LED: On/Flash
Global Status Indicator LED	Overall status of the product	Flash - Green	Self-test in progress during UBOOT, SVOS and AOS-CX
		On - Green	Successfully initialized AOS-CX
		Flash - Amber	Recoverable faults (e.g. fans, PSU fault)
		On - Amber	Critical faults (e.g. exceed temperature limit)
*Press the LED mode button to switch between Link/Activity (default), PoE, or Speed.			
**Applicable only when the 6100 switch is in stack mode.			

To use the LEDs for general troubleshooting, check the table for the LED pattern you see then refer to the corresponding diagnostic tip in the next table.

**Table 4: LED error indicators**

Global status	Port LED	Diagnostic tip
Off with power cord plugged in		1
Solid orange		2
Slow flash orange		3
Slow flash orange	Slow flash orange*	4
Solid green	Off with cable connected	5
Solid green	On, but the port is not communicating	6
*The flashing behavior is an on/off cycle once every 1.6 seconds, approximately.		

**Table 5: Diagnostic tips**

Tip	Problem	Solution
1	The switch is not plugged into an active AC power	1. Verify that the power cord is plugged into an active power

Tip	Problem	Solution
	source, or the switch power supply may have failed.	<p>source and to the switch. Make sure that these connections are snug.</p> <ol style="list-style-type: none"> <li>2. Try power cycling the switch by unplugging and plugging the power cord back in.</li> <li>3. If the Global Status LED is still not on, verify that the AC power source works by plugging another device into the outlet. Or try plugging the switch into a different outlet or try a different power cord.</li> </ol>
2	A switch hardware failure has occurred. All the LEDs will stay on indefinitely.	Try power cycling the switch. If the fault indication reoccurs, the switch may have failed. To get assistance, either call your Aruba authorized network reseller, or use the electronic support services from Aruba.
3	The switch has experienced a software failure during self-test, or a hardware component is having issues.	<p>Check the switch Event Log for indication of the fault condition, if a port failed self-test, contact Aruba support.</p> <ol style="list-style-type: none"> <li>1. Try resetting the switch by pressing the Reset button on the front of the switch, or by power cycling the switch.</li> <li>2. If the fault indication reoccurs, attach a console to the switch and configure it to operate at 115200 baud. Then, reset the switch. Messages should appear on the console screen and in the console log identifying the error condition.</li> </ol> <p>If necessary to resolve the problem, contact your Aruba authorized network reseller, or use the electronic support services from Aruba to get assistance.</p>
4	The network port for which the LED is blinking has experienced a self-test or initialization failure.	<p>Try power cycling the switch. If the fault indication reoccurs, the switch port may have failed. Call your Aruba authorized network reseller, or use the electronic support services from Aruba to get assistance.</p> <p>If the port is an SFP, verify it is one of the SFPs supported by the switch. Unsupported SFPs will be identified with this fault condition. The SFPs are also tested when they are "hot-swapped" – installed or changed while the switch is powered on.</p> <p>To verify that the port has failed, try removing and reinstalling the SFP without powering off the switch. If the port fault indication reoccurs, you will have to replace the SFP. Check the event log to see why the SFP failed.</p>
5	The network connection is not working properly.	<p>Try the following procedures:</p> <ul style="list-style-type: none"> <li>■ For the indicated port, verify both ends of the cabling, at the switch and the connected device, are connected properly.</li> <li>■ Verify the connected device and switch are both powered on and operating correctly.</li> <li>■ Verify that you have used the correct cable type for the connection: <ul style="list-style-type: none"> <li>○ For twisted-pair connections to the fixed 10/100/1000 ports, if the port is configured to "Auto" (auto negotiate), either straight-through or crossover cables can be used because of the switch "Auto-MDIX" feature and the Auto MDI/MDI-X feature of the 10/100/1000-T port.</li> </ul> </li> </ul>

Tip	Problem	Solution
		<p><b>NOTE:</b> If the switch port configuration is changed to one of the fixed configuration options (for example, 100 Mbps/Full Duplex), then the port operates as MDI-X only and you must use the correct type of cable for the connection. In general, for connecting an end node(MDI port) to the switch, use straight through cable; for connecting to MDI-X ports on hubs, other switches, and routers, use crossover cable.</p> <ul style="list-style-type: none"> <li>◦ For fiber-optic connections, verify that the transmit port on the switch is connected to the receive port on the connected device, and the switch receive port is connected to the transmit port on the connected device.</li> <li>■ For 1000BASE-T connections, verify that the network cabling complies with the IEEE 802.3ab standard. Install the cable according to the ANSI/TIA/EIA-568-A-5 specifications. Ensure that the cable testing complies with the stated limitations for Attenuation, Near-End Crosstalk, Far-End Crosstalk, Equal-Level Far-End Crosstalk (ELFEXT), Multiple Disturber ELFEXT, and Return Loss. The cable verification process must include all patch cables from any end devices, including the switch, to any patch panels in the cabling path.</li> <li>■ Verify that the port has not been disabled through a switch configuration change. You can use the console interface, or, if you have configured an IP address on the switch, use the web browser interface to determine the state of the port and re-enable the port if necessary.</li> <li>■ Verify that the switch port configuration matches the configuration of the attached device. For example, if the switch port is configured as "Auto", the port on the attached device also MUST be configured as "Auto". Depending on the port type, twisted-pair or fiber-optic, if the configurations do not match, the results could be a very unreliable connection, or no link at all.</li> <li>■ If the other procedures do not resolve the problem, try using a different port or a different cable.</li> </ul>
6	The port or remote link partner may be improperly configured, or the port may be in a "blocking" state by the normal operation of protocols, such as Spanning Tree, LACP, or MVRP features.	<ul style="list-style-type: none"> <li>■ You must ensure that the device at the other end of the connection indicates a good link to the switch. If it does not, the problem may be with the cabling between the devices, the connectors on the cable, or the configuration of the device on the remote end of the cable.</li> <li>■ Use the switch console to see if the port is part of a dynamic trunk (through the LACP feature) or to see if Spanning Tree is enabled on the switch, and to see if the port may have been put into a "blocking" state by those features. The show lacp command displays the port status for the LACP feature; the show Spanning Tree command displays the port status for Spanning Tree. Other switch features that may affect the port operation include VLANs and IGMP. Use the switch console to see how the port is configured for these features.</li> </ul>

## Proactive networking

The switches have built-in management capabilities that proactively help you manage your network, they include:

- Finding and helping you fix the most common network error conditions (for example, faulty network cabling, and nonstandard network topologies).
- Informing you of the problem with clear, easy-to-understand messages.
- Recommending network configuration changes to enhance the performance of your network.

The following interfaces provide tests, indicators, and an event log that can be used to monitor the switch and its network connections:

- A graphical web browser interface that you can use to manage your switch from a PC running a supported web browser, for example, Google Chrome.
  - A full-featured easy-to-use console interface that you can access by connecting a standard terminal or PC running a terminal emulator to the switch console port using an USB-C to USB-A cable (sold separately). The console command-line interface is also accessible through a Telnet or SSH connection.
-

# Hardware diagnostic tests

## Testing the switch by resetting it

If you believe the switch is not operating correctly, you can reset the switch to test its circuitry and operating code. To reset a switch, try any of the following:

- Unplug and plug in the power cord (power cycling).
- Press the Reset button on the front of the switch.
- Reboot the switch with the management console's `boot system` command.

Power cycling the switch and pressing the Reset button both cause the switch to perform its power-on self test, which almost always will resolve any temporary operational problems. These reset processes also cause any network traffic counters to be reset to zero, and cause the System Up Time timer to reset to zero.

## Checking the switch LEDs

See [Diagnosing with the LEDs](#) for information on interpreting the LED patterns and LED behaviors.

## Checking console messages

Useful diagnostic messages may be displayed on the console screen when you reset a switch. Connect a PC running a VT-100 terminal emulator program or a standard VT-100 terminal to the switch console port. Configure the terminal to run at 115200 baud, and with the other terminal communication settings.

When you reset the switch, note the messages that are displayed. Additionally, you can check the switch event log, which can be accessed from the console using the `show log` command, or from the console main menu.

## Testing twisted-pair cabling

Network cables that fail to provide a link or provide an unreliable link between the switch and the connected network device may not be compatible with the IEEE 802.3 Type 10BASE-T, 100BASE-TX, or 1000BASE-T standards. The twisted-pair cables attached to the switch must be compatible with the appropriate standards. To verify your cable is compatible with these standards, use a qualified cable test device.

## Testing switch-to-device network communications

The following communication tests can verify that the network is operating correctly between the switch and any connected device that can respond correctly to the communication test.

- Link Test: A physical layer test that sends IEEE 802.2 test packets to any device identified by its MAC address.
- Ping Test: A network layer test used on IP networks that sends test packets to any device identified by its IP address.

These tests can be performed through the switch console interface. Use a terminal connected directly to the switch or through a Telnet connection, or from the switch web browser interface. For more information, see the *Fundamentals Guide* for your switch.

These tests can also be performed from an SNMP network management station running a program that can manage the switch, like AirWave.

## Testing end-to-end network communications

Both the switch and the cabling can be tested by running an end-to-end communications test. This is a test that sends known data from one network device to another through the switch. For example, if you have two PCs on the network that have LAN adapters between which you can run a link-level test or Ping test through the switch, you can use this test to verify that the entire communication path between the two PCs is functioning correctly. See your LAN adapter documentation for more information on running a link test or Ping test.

## Restoring the factory default configuration

As part of your troubleshooting process on the switch, it may become necessary to return the switch configuration to the factory default settings. This process momentarily interrupts the switch operation, clears any passwords, clears the console event log, resets the network counters to zero, performs a complete self-test, and reboots the switch into its factory default configuration, including deleting the IP address, if one is configured.

---

This process removes all switch configuration changes made from the factory default settings. This operation includes, for example, configuration of VLANs, spanning tree, and trunks. Returning the configuration of these features to their factory default settings (usually disabling them) may result in network connectivity issues.



If the switch has a valid configuration, and you are restoring the factory default settings for a reason other than configuration problems, save the switch configuration prior to performing the factory default reset. After the reset and resolution of the original problem, you can restore the saved configuration to the switch.

---

To restore the factory default configuration using the console, execute the `erase startup-config` command from the console command prompt.

## Downloading new switch software

Software updates can be downloaded to the switch through several methods. For more information, see [Support and Other Resources](#).

## Environmental specifications

**Table 1:** Specifications for all Hewlett Packard Enterprise 6000 and 6100 switch models

Specification	Value
Operating temperature	32°F to 113°F up to 5,000 ft (0°C to 45°C up to 1.5 km) * Derate 1°C for every 1,000 ft to 10,000 ft (300 m to 3.0 km)
Non-operating temperature	-40°F to 158°F up to 15,000 ft (-40°C to 70°C up to 4.6 km)
Operating relative humidity	5% to 95% @ 104°F (40°C) non-condensing
Non-operative storage relative humidity	5% to 95% @ 149°F (65°C) non-condensing
Max operating altitude	10,000 ft (3.0 km) Max
Max non-operating altitude	15,000 ft (4.6 km) Max
* 32°F to 104°F (0°C to 40°C) for R8N89B, S4R21A, S4R22A, S4R23A, S4R28A, and S4R29A	

**Table 2:** Dimensions and weights for 6000 switch models

Switch	Dimensions (W x D x H)	Weight
HPE Aruba Networking 6000 48G Class4 PoE 4SFP 740W Switch (R9Y03A)	17.43 x 12.77 x 1.73 in (44.25 x 32.42 x 4.39 cm)	10.36 lb (4.70 kg)
HPE Aruba Networking 6000 48G Class4 PoE 4SFP 370W Switch (R8N85A)	17.4 x 12 x 1.73 in (44.25 x 30.55 x 4.40 cm)	9.75 lb (4.42 kg)
HPE Aruba Networking 6000 48G 4SFP Switch (R8N86A)	17.4 x 9.74 x 1.73 in (44.25 x 24.73 x 4.40 cm)	6.65 lb (3.02 kg)
HPE Aruba Networking 6000 24G Class4 PoE 4SFP 370W Switch (R8N87A)	17.4 x 10.56 x 1.73 in (44.25 x 26.82 x 4.40 cm)	7.95 lb (3.62 kg)
HPE Aruba Networking 6000 24G 4SFP Switch (R8N88A)	17.4 x 7.92 x 1.73 in (44.25 x 20.12 x 4.40 cm)	5.05 lb (2.30 kg)
HPE Aruba Networking 6000 12G Class4 PoE 2G/2SFP 139W Switch (R8N89A)	10 x 10.04 x 1.73 in (25.4 x 25.49 x 4.40 cm)	4.80 lb (2.18 kg)

Switch	Dimensions (W x D x H)	Weight
HPE Aruba Networking 6000 48G Class4 PoE 4SFP 740W Switch (R9Y03B)	17.42 x 12 x 1.73 in (44.25 x 30.44 x 4.39 cm)	9.55 lb (4.33 kg)
HPE Aruba Networking 6000 48G Class4 PoE 4SFP 370W Switch (R8N85B)	17.42 x 12 x 1.73 in (44.25 x 30.44 x 4.39 cm)	9.68 lb (4.39 kg)
HPE Aruba Networking 6000 48G 4SFP Switch (R8N86B)	17.42 x 9.7 x 1.73 in (44.25 x 24.65 x 4.39 cm)	6.57 lb (2.98 kg)
HPE Aruba Networking 6000 24G Class4 PoE 4SFP 370W Switch (R8N87B)	17.42 x 10.56 x 1.73 in (44.25 x 26.82 x 4.39 cm)	8.11 lb (3.68 kg)
HPE Aruba Networking 6000 24G 4SFP Switch (R8N88B)	17.42 x 7.92 x 1.73 in (44.25 x 20.12 x 4.39 cm)	5.05 lb (2.29 kg)
HPE Aruba Networking 6000 12G Class4 PoE 2SFP 139W Switch (R8N89B)	10 x 10.04 x 1.73 in (25.4 x 25.5 x 4.39 cm)	4.78 lb (2.17 kg)
HPE Aruba Networking 6000 48G Class4 PoE 4SFP 740W TAA Switch (S4R20A)	17.42 x 12 x 1.73 in (44.25 x 30.44 x 4.39 cm)	9.55 lb (4.33 kg)
HPE Aruba Networking 6000 12G Class4 PoE 2SFP 139W TAA Switch (S4R21A)	10 x 10.04 x 1.73 in (25.4 x 25.5 x 4.39 cm)	4.78 lb (2.17 kg)
HPE Aruba Networking 6000 8G 2SFP Switch (S4R22A)	8.9 x 5.74 x 1.73 in (22.6 x 14.59 x 4.39 cm)	2.20 lb (1 kg)
HPE Aruba Networking 6000 8G Class4 PoE 2SFP 67W Switch (S4R23A)	10 x 10.04 x 1.73 in (25.4 x 25.5 x 4.39 cm)	4.14 lb (1.88 kg)
HPE Aruba Networking 6000 48G Class4 PoE 4SFP 370W TAA Switch (S4R24A)	17.42 x 12 x 1.73 in (44.25 x 30.44 x 4.39 cm)	9.68 lb (4.39 kg)
HPE Aruba Networking 6000 48G 4SFP TAA Switch (S4R25A)	17.42 x 9.7 x 1.73 in (44.25 x 24.65 x 4.39 cm)	6.57 lb (2.98 kg)
HPE Aruba Networking 6000 24G Class4 PoE 4SFP 370W TAA Switch (S4R26A)	17.42 x 10.56 x 1.73 in (44.25 x 26.82 x 4.39 cm)	8.11 lb (3.68 kg)
HPE Aruba Networking 6000 24G 4SFP TAA Switch (S4R27A)	17.42 x 7.92 x 1.73 in (44.25 x 20.12 x 4.39 cm)	5.05 lb (2.29 kg)

Switch	Dimensions (W x D x H)	Weight
HPE Aruba Networking 6000 8G 2SFP TAA Switch (S4R28A)	8.9 x 5.74 x 1.73 in (22.6 x 14.59 x 4.39 cm)	2.20 lb (1 kg)
HPE Aruba Networking 6000 8G Class4 PoE 2SFP 67W TAA Switch (S4R29A)	10 x 10.04 x 1.73 in (25.4 x 25.5 x 4.39 cm)	4.14 lb (1.88 kg)

**Table 3:** Dimensions and weights for 6100 switch models

Switch	Dimensions (W x D x H)	Weight
HPE Aruba Networking 6100 48G Class4 PoE 4SFP+ 740W Switch (R9Y04A)	17.43 x 12.77 x 1.73 in (44.25 x 32.42 x 4.39 cm)	10.36 lb (4.70 kg)
HPE Aruba Networking 6100 48G Class4 PoE 4SFP+ 370W Switch (JL675A)	17.4 x 12 x 1.73 in (44.25 x 30.55 x 4.40 cm)	9.75 lb (4.42 kg)
HPE Aruba Networking 6100 48G 4SFP+ Switch (JL676A)	17.4 x 9.74 x 1.73 in (44.25 x 24.73 x 4.40 cm)	6.65 lb (3.02 kg)
HPE Aruba Networking 6100 24G Class4 PoE 4SFP+ 370W Switch (JL677A)	17.4 x 10.56 x 1.73 in (44.25 x 26.82 x 4.40 cm)	7.95 lb (3.62 kg)
HPE Aruba Networking 6100 24G 4SFP+ Switch (JL678A)	17.4 x 7.92 x 1.73 in (44.25 x 20.12 x 4.40 cm)	5.05 lb (2.30 kg)
HPE Aruba Networking 6100 12G Class4 PoE 2G/2SFP+ 139W Switch (JL679A)	10 x 10.04 x 1.73 in (25.4 x 25.49 x 4.40 cm)	4.80 lb (2.18 kg)

## Electrical

**Table 1:** Electrical information for 6000 switch models

Model	Description	Input Voltage	Maximum current	Frequency range	Maximum power
R9Y03A	HPE Aruba Networking 6000 48G Class4 PoE 4SFP 740W Switch	100-127VAC 200-240VAC	9.2A 4.9A	50/60 Hz	890W
R8N85A	HPE Aruba Networking 6000 48G Class4 PoE 4SFP 370W Switch	100-127VAC 200-240VAC	4.9A 2.4A	50/60 Hz	480W
R8N86A	HPE Aruba	100-127VAC	0.8A	50/60 Hz	44W

Model	Description	Input Voltage	Maximum current	Frequency range	Maximum power
	Networking 6000 48G 4SFP Switch	200-240VAC	0.5A		
R8N87A	HPE Aruba Networking 6000 24G Class4 PoE 4SFP 370W Switch	100-127VAC 200-240VAC	4.6A 2.3A	50/60 Hz	455W
R8N88A	HPE Aruba Networking 6000 24G 4SFP Switch	100-127VAC 200-240VAC	0.6A 0.4A	50/60 Hz	33W
R8N89A	HPE Aruba Networking 6000 12G Class4 PoE 2G/2SFP 139W Switch	100-127VAC 200-240VAC	1.8A 0.9A	50/60 Hz	170W
R9Y03B	HPE Aruba Networking 6000 48G Class4 PoE 4SFP 740W Switch	100-127VAC 200-240VAC	9.3A 4.5A	50/60 Hz	818W
R8N85B	HPE Aruba Networking 6000 48G Class4 PoE 4SFP 370W Switch	100-127VAC 200-240VAC	4.9A 2.4A	50/60 Hz	439W
R8N86B	HPE Aruba Networking 6000 48G 4SFP Switch	100-127VAC 200-240VAC	0.8A 0.5A	50/60 Hz	35.2W
R8N87B	HPE Aruba Networking 6000 24G Class4 PoE 4SFP 370W Switch	100-127VAC 200-240VAC	4.6A 2.3A	50/60 Hz	409W
R8N88B	HPE Aruba Networking 6000 24G 4SFP Switch	100-127VAC 200-240VAC	0.6A 0.4A	50/60 Hz	22.4W
R8N89B	HPE Aruba Networking 6000 12G Class4 PoE 2SFP 139W Switch	100-127VAC 200-240VAC	1.8A 0.9A	50/60 Hz	165W
S4R20A	HPE Aruba Networking 6000 48G Class4 PoE 4SFP 740W TAA Switch	100-127VAC 200-240VAC	9.3A 4.5A	50/60 Hz	818W
S4R21A	HPE Aruba Networking 6000 12G Class4 PoE 2SFP 139W TAA Switch	100-127VAC 200-240VAC	1.8A 0.9A	50/60 Hz	165W

Model	Description	Input Voltage	Maximum current	Frequency range	Maximum power
S4R22A	HPE Aruba Networking 6000 8G 2SFP Switch	DC 12V	2A	N/A	13.8W
S4R23A	HPE Aruba Networking 6000 8G Class4 PoE 2SFP 67W Switch	100-127VAC 200-240VAC	1.0A 0.5A	50/60 Hz	98W
S4R24A	HPE Aruba Networking 6000 48G Class4 PoE 4SFP 370W TAA Switch	100-127VAC 200-240VAC	4.9A 2.4A	50/60 Hz	439W
S4R25A	HPE Aruba Networking 6000 48G 4SFP TAA Switch	100-127VAC 200-240VAC	0.8A 0.5A	50/60 Hz	35.2W
S4R26A	HPE Aruba Networking 6000 24G Class4 PoE 4SFP 370W TAA Switch	100-127VAC 200-240VAC	4.6A 2.3A	50/60 Hz	409W
S4R27A	HPE Aruba Networking 6000 24G 4SFP TAA Switch	100-127VAC 200-240VAC	0.6A 0.4A	50/60 Hz	22.4W
S4R28A	HPE Aruba Networking 6000 8G 2SFP TAA Switch	DC 12V	2A	N/A	13.8W
S4R29A	HPE Aruba Networking 6000 8G Class4 PoE 2SFP 67W TAA Switch	100-127VAC 200-240VAC	1.0A 0.5A	50/60 Hz	98W

**Table 2:** Electrical information for 6100 switch models

Model	Description	Input Voltage	Maximum current	Frequency range	Maximum power
R9Y04A	HPE Aruba Networking 6100 48G Class4 PoE 4SFP+ 740W Switch	100-127VAC 200-240VAC	9.2A 4.9A	50/60 Hz	890W
JL675A	HPE Aruba Networking 6100 48G Class4 PoE 4SFP+ 370W Switch	100-127VAC 200-240VAC	4.9A 2.4A	50/60 Hz	480W

Model	Description	Input Voltage	Maximum current	Frequency range	Maximum power
JL676A	HPE Aruba Networking 6100 48G 4SFP+ Switch	100-127VAC 200-240VAC	0.8A 0.5A	50/60 Hz	44W
JL677A	HPE Aruba Networking 6100 24G Class4 PoE 4SFP+ 370W Switch	100-127VAC 200-240VAC	4.6A 2.3A	50/60 Hz	455W
JL678A	HPE Aruba Networking 6100 24G 4SFP+ Switch	100-127VAC 200-240VAC	0.6A 0.4A	50/60 Hz	33W
JL679A	HPE Aruba Networking 6100 12G Class4 PoE 2G/2SFP+ 139W Switch	100-127VAC 200-240VAC	1.8A 0.9A	50/60 Hz	170W



Maximum power includes POE draw where applicable with switch running at maximum.

## Acoustics

**Table 1:** 6000 Switches tested to IDLE acoustics configuration

Product	Acoustics
<b>R9Y03A</b> HPE Aruba Networking 6000 48G Class4 PoE 4SFP 740W Switch	Sound Power (LWAd) 4.95 Bel Sound Pressure (LpAm) (Bystander) 35.91 dB
<b>R8N85A</b> HPE Aruba Networking 6000 48G Class4 PoE 4SFP 370W Switch	Sound Power (LWAd) 4.3 Bel Sound Pressure (LpAm) (Bystander) 29.8 dB
<b>R8N86A</b> HPE Aruba Networking 6000 48G 4SFP Switch	Sound Power (LWAd) 3.6 Bel Sound Pressure (LpAm) (Bystander) 24.6 dB
<b>R8N87A</b> HPE Aruba Networking 6000 24G Class4 PoE 4SFP 370W Switch	Sound Power (LWAd) 3.9 Bel Sound Pressure (LpAm) (Bystander) 24.3 dB
<b>R8N88A</b> HPE Aruba Networking 6000 24G 4SFP Switch	Sound Power (LWAd) 3.9 Bel Sound Pressure (LpAm) (Bystander) 20.9 dB
<b>R8N89A</b> HPE Aruba Networking 6000 12G Class4 PoE 2G/2SFP 139W Switch	Sound Power (LWAd) 0 Bel Sound Pressure (LpAm) (Bystander) 0 dB

**Table 2:** 6000 Switches tested to typical acoustics configuration

Product	Acoustics
<b>R9Y03B</b> HPE Aruba Networking 6000 48G Class4 PoE 4SFP 1G 740W Switch	Sound Power (LWAd) 5.9 Bel Sound Pressure (LpAm) (Bystander) 40.6 dB

Product	Acoustics
<b>R8N85B</b> HPE Aruba Networking 6000 48G Class4 PoE 4SFP 1G 370W Switch	Sound Power (LWAd) 5.4 Bel Sound Pressure (LpAm) (Bystander) 37.6 dB
<b>R8N86B</b> HPE Aruba Networking 6000 48G 4SFP 1G Switch	Sound Power (LWAd) 3.8 Bel Sound Pressure (LpAm) (Bystander) 33.1 dB
<b>R8N87B</b> HPE Aruba Networking 6000 24G Class4 PoE 4SFP 1G 370W Switch	Sound Power (LWAd) 4.1 Bel Sound Pressure (LpAm) (Bystander) 24.9 dB
<b>R8N88B</b> HPE Aruba Networking 6000 24G 4SFP 1G Switch	Sound Power (LWAd) 4.5 Bel Sound Pressure (LpAm) (Bystander) 28.2 dB
<b>R8N89B</b> HPE Aruba Networking 6000 12G Class4 PoE 2SFP 1G 139W Switch	Sound Power (LWAd) 0 Bel Sound Pressure (LpAm) (Bystander) 0 dB
<b>S4R22A</b> HPE Aruba Networking 6000 8G 2SFP 1G Switch	Sound Power (LWAd) 0 Bel Sound Pressure (LpAm) (Bystander) 0 dB
<b>S4R23A</b> HPE Aruba Networking 6000 8G Class4 PoE 2SFP 1G 67W Switch	Sound Power (LWAd) 0 Bel Sound Pressure (LpAm) (Bystander) 0 dB
<b>S4R20A</b> HPE Aruba Networking 6000 48G Class4 PoE 4SFP 1G 740W TAA Switch	Sound Power (LWAd) 5.9 Bel Sound Pressure (LpAm) (Bystander) 40.6 dB
<b>S4R21A</b> HPE Aruba Networking 6000 12G Class4 PoE 2SFP 1G 139W TAA Switch	Sound Power (LWAd) 0 Bel Sound Pressure (LpAm) (Bystander) 0 dB
<b>S4R24A</b> HPE Aruba Networking 6000 48G Class4 PoE 4SFP 1G 370W TAA Switch	Sound Power (LWAd) 5.4 Bel Sound Pressure (LpAm) (Bystander) 37.6 dB
<b>S4R25A</b> HPE Aruba Networking 6000 48G 4SFP 1G TAA Switch	Sound Power (LWAd) 3.8 Bel Sound Pressure (LpAm) (Bystander) 33.1 dB
<b>S4R26A</b> HPE Aruba Networking 6000 24G Class4 PoE 4SFP 1G 370W TAA Switch	Sound Power (LWAd) 4.1 Bel Sound Pressure (LpAm) (Bystander) 24.9 dB
<b>S4R27A</b> HPE Aruba Networking 6000 24G 4SFP 1G TAA Switch	Sound Power (LWAd) 4.5 Bel Sound Pressure (LpAm) (Bystander) 28.2 dB
<b>S4R28A</b> HPE Aruba Networking 6000 8G 2SFP 1G TAA Switch	Sound Power (LWAd) 0 Bel Sound Pressure (LpAm) (Bystander) 0 dB
<b>S4R29A</b> HPE Aruba Networking 6000 8G Class4 PoE 2SFP 1G 67W TAA	Sound Power (LWAd) 0 Bel Sound Pressure (LpAm) (Bystander) 0 dB
Typical Acoustics Configuration: 50% traffic, 50% POE (where applicable), and fully populated with transceivers.	

**Table 3:** 6100 Switches tested to IDLE acoustics configuration

Product	Acoustics
<b>R9Y04A</b> HPE Aruba Networking 6100 48G Class4 PoE 4SFP+ 740W Switch	Sound Power (LWAd) 4.95 Bel Sound Pressure (LpAm) (Bystander) 35.91 dB
<b>JL675A</b> HPE Aruba Networking 6100 48G Class4 PoE 4SFP+ 370W Switch	Sound Power (LWAd) 4.3 Bel Sound Pressure (LpAm) (Bystander) 29.8 dB

Product	Acoustics
<b>JL676A</b> HPE Aruba Networking 6100 48G 4SFP+ Switch	Sound Power (LWAd) 3.6 Bel Sound Pressure (LpAm) (Bystander) 24.6 dB
<b>JL677A</b> HPE Aruba Networking 6100 24G Class4 PoE 4SFP+ 370W Switch	Sound Power (LWAd) 3.9 Bel Sound Pressure (LpAm) (Bystander) 24.3 dB
<b>JL678A</b> HPE Aruba Networking 6100 24G 4SFP+ Switch	Sound Power (LWAd) 3.9 Bel Sound Pressure (LpAm) (Bystander) 20.9 dB
<b>JL679A</b> HPE Aruba Networking 6100 12G Class4 PoE 2G/2SFP+ 139W Switch	Sound Power (LWAd) 0 Bel Sound Pressure (LpAm) (Bystander) 0 dB

## Safety and regulatory information

### Lasers

EN 60825-1:2014 / IEC 60825-1:2014 Class 1

Class 1 Laser Products / Laser Klasse 1

(Applicable for accessories - Optical Transceivers only)

### Safety and Regulatory information

Safety-EU	EN 62368-1: 2018 EN 62368-1:2014
Safety-Worldwide	IEC 62368-1: 2018 IEC 62368-1:2014
Safety-North America	UL/CUL 62368-1: 2018 UL/CUL 62368-1: 2014
EMC	BS/EN 55032:2015+A11:2020/CISPR 32, Class A BS/EN 55035:2017+A11:2020/CISPR 35, Class A FCC CFR 47 Part 15:2018, Class A ICES-003 Issue 7, Class A VCCI-32, Class A CNS 15936, Class A KS C 9832, KS C 9835, Class A AS/NZS CISPR 32, Class A EN IEC 61000-3-2:2019/A1:2021 EN 61000-3-3:2013/A2:2021
RoHS	EN IEC 63000:2018

# Connectivity standards

**Table 1:** *Technology standards and safety compliance*

		Laser safety information	
Technology	Compatible with these IEEE standards	EN/IEC standard compliance	SFP+Lasers
10-T, 100-TX, 1000-T	IEEE 802.3 10BASE-T IEEE 802.3u 100BASE-TX IEEE 802.3ab 1000BASE-T		
10-Gig SR	IEEE 802.3ae 10GBASE-SR	EN/IEC 60825	Class 1 Laser Product Laser Klasse 1
10-Gig LR	IEEE 802.3ae 10GBASE-LR	EN/IEC 60825	Class 1 Laser Product Laser Klasse 1
Power over Ethernet (PoE) over 2-pairs	IEEE 802.3at IEEE 802.3af		

This section includes switch connector information and network cable information for cables used with the Aruba switches.



Incorrectly wired cabling is a common cause of problems for LAN communications. Aruba recommends that you work with a qualified LAN cable installer for assistance with your cabling requirements.

### Cabling specifications

**Table 1:** *Cabling specifications*

<b>Twisted-pair copper</b>	10 Mbps Operation	Category 3, 4 or 5, 100-ohm unshielded twisted-pair (UTP) or shielded twisted-pair (STP) cable, complying with IEEE 802.3 10BASE-T specifications.
	100 Mbps Operation	Category 5, 100-ohm UTP, or STP cable, complying with IEEE 802.3u 100BASE-TX specifications.
	1000 Mbps Operation	Category 5, 100-ohm 4-pair UTP or STP cable, complying with IEEE 802.3ab 1000BASE-T specifications; Category 5e or better is recommended.
<b>Multimode fiber</b>		62.5/125 $\mu\text{m}$ or 50/125 $\mu\text{m}$ (core/cladding) diameter, low metal content, graded index fiber-optic cables, complying with the ITU-T G.651 and ISO/IEC 793-2 Type A1b or A1a standards respectively.*
<b>Single mode fiber</b>		9/125 $\mu\text{m}$ (core/cladding) diameter, low metal content fiber-optic cables, complying with the ITU-T G.652 and ISO/IEC 793-2 Type B1 standards.
*A mode conditioning patch cord may be needed for some Gigabit-LX and 10-Gigabit LRM installations.		

#### Note on Multimode and Single mode fiber

Attenuators may be required for some transceiver techs and cable length

#### Note on 1000BASE-T cable requirements

The Category 5 networking cables that work for 100BASE-TX connections also work for 1000BASE-T, as long as all four-pairs are connected. But, for the most robust connections, use cabling that complies with the Category 5e specifications. This specification is described in Addendum 5 to the TIA-568-A standard (ANSI/TIA/EIA-568-A-5).

Because of the increased speed provided by 1000BASE-T (Gigabit-T), network cable quality is more important than for either 10BASE-T or 100BASE-TX. Cabling plants being used to carry 1000BASE-T networking must comply with the IEEE 802.3ab standards. In particular, the cabling must pass tests for Attenuation, Near-End Crosstalk (NEXT), and Far-End Crosstalk (FEXT). Additionally, unlike the cables for 100BASE-TX, the 1000BASE-T cables must pass tests for Equal-Level Far-End Crosstalk (ELFEXT) and Return Loss.

When testing your cabling, be sure to include the patch cables that connect the switch and other end devices to the patch panels on your site. The patch cables are frequently overlooked when testing cable and they must also comply with the cabling standards.

## Technology distance specifications

**Table 1:** *Technology distance specifications*

Technology	Supported cable type	Multimode fibemodal bandwidth	Supported distances
1000-T	twisted-pair copper	N/A	up to 100 meters
1000-SX	multimode fiber	160 MHz*km 200 MHz*km 400 MHz*km 500 MHz*km	2 - 220 meters 2 - 275 meters 2 - 500 meters 2 - 550 meters
1000-LX	multimode fiber single mode fibe	400 MHz*km 500 MHz*km N/A	2 - 550 meters 2 - 550 meters 2 - 10,000 meters
10-Gig SR	multimode fiber	160 MHz*km 200 MHz*km 400 MHz*km 500 MHz*km 2000 MHz*km	2 - 26 meters 2 - 33 meters 2 - 66 meters 2 - 82 meters 2 - 300 meters
10-Gig LR	single mode fiber	N/A	2 - 10,000 meters



Consult the Datasheet for supported transceivers for this series.

## Twisted-pair cable/connector pin-outs

### Auto-MDIX feature:

The 10/100/1000-T ports support the IEEE 802.3ab standard, which includes the "Auto MDI/MDI-X" feature. In the default configuration, "Auto", the ports on the switch will automatically detect the type of port on the connected device and operate as either an MDI or MDI-X port, whichever is appropriate. So for any connection, a straight-through twisted-pair cable can be used. You no longer have to use crossover cables, although crossover cables can also be used for any of the connections.

If you connect a switch twisted-pair port to another switch or hub, which typically have MDI-X ports, the port automatically operates as an MDI port. If you connect it to an end node, such as a server or PC, which typically have MDI ports, the switch port operates as an MDI-X port. In all cases, you can use standard straight-through cables or crossover cables.

If you use a correctly-wired crossover cable, though, the switch will still be able to automatically detect the MDI/MDI-X operation and link correctly to the connected device.

### Other wiring rules:

- All twisted-pair wires used for 10 Mbps, and 100 Mbps operation must be twisted through the entire length of the cable. The wiring sequence must conform to EIA/TIA 568-B (not USOC). See [Pin assignments](#) for a listing of the signals used on each pin.
- For 1000BASE-T connections, all four pairs of wires in the cable must be available for data transmission.
- For 10 Mbps connections to the ports, you can use Category 3, 4, or 5 unshielded twisted-pair cable, as supported by the IEEE 802.3 Type 10BASE-T standard.
- For 100 Mbps connections to the ports, use 100-ohm Category 5 UTP or STP cable only, as supported by the IEEE 802.3u Type 100BASE-TX standard.
- For 1000 Mbps connections, 100-ohm Category 5e or better cabling is recommended.

## Straight-through twisted-pair cable for 10 Mbps or 100 Mbps network connections

Because of the Aruba Auto-MDIX operation of the 10/100 ports on the switch, for all network connections, to PCs, servers or other end nodes, or to hubs or other switches, you can use straight-through cables.

If any of these ports are given a fixed configuration, for example 100 Mbps/Full Duplex, the ports operate as MDI-X ports, and straight-through cables must be then used for connections to PC NICs and other MDI ports.

### Cable diagram

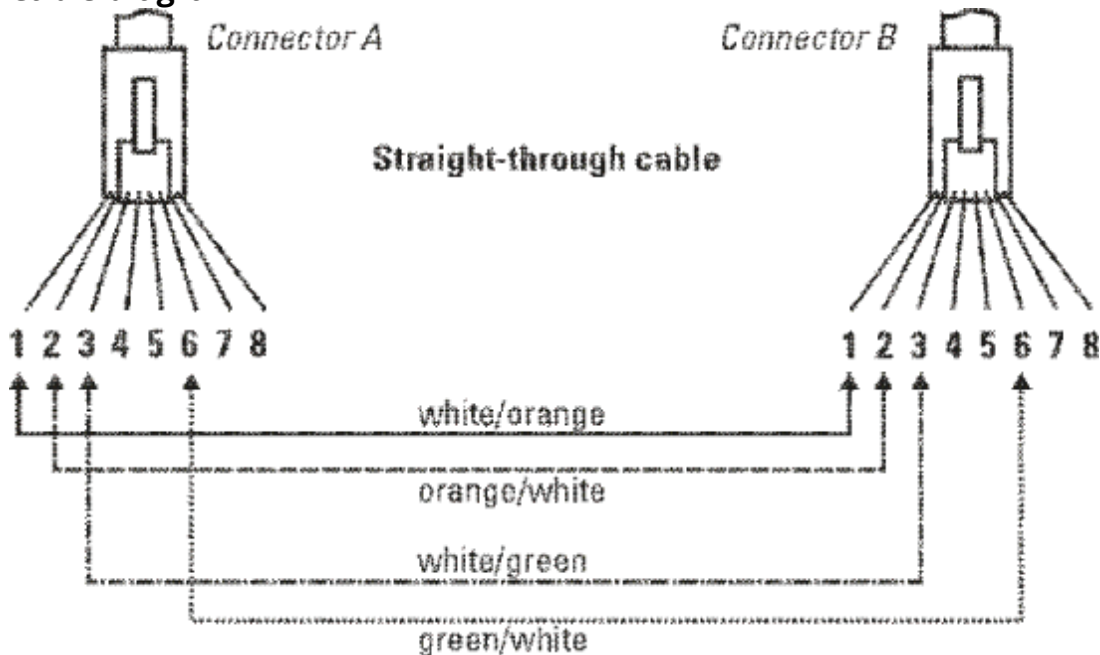

- Pins 1 and 2 on connector "A" must be wired as a twisted pair to pins 1 and 2 on connector "B".
- Pins 3 and 6 on connector "A" must be wired as a twisted pair to pins 3 and 6 on connector "B".
- Pins 4, 5, 7, and 8 are not used in this application, although they may be wired in the cable.



NOTE

## Pin assignments

Switch end (MDI-X)			Computer, transceiver, or other end	
Signal	Pins		Pins	Signal
receive +	1	<-----	1	transmit +
receive -	2	<-----	2	transmit -
transmit +	3	----->	3	receive +
transmit -	6	----->	6	receive -

## Crossover twisted-pair cable for 10 Mbps or 100 Mbps network connection

The Auto-MDIX operation of the 10/100 ports on the switch also allows you to use crossover cables for all network connections, to PCs, servers or other end nodes, or to hubs or other switches.

If any of these ports are given a fixed configuration, for example 100 Mbps/Full Duplex, the ports operate as MDI-X ports, and crossover cables must be then used for connections to hubs or switches or other MDI-X network devices.

### Cable diagram

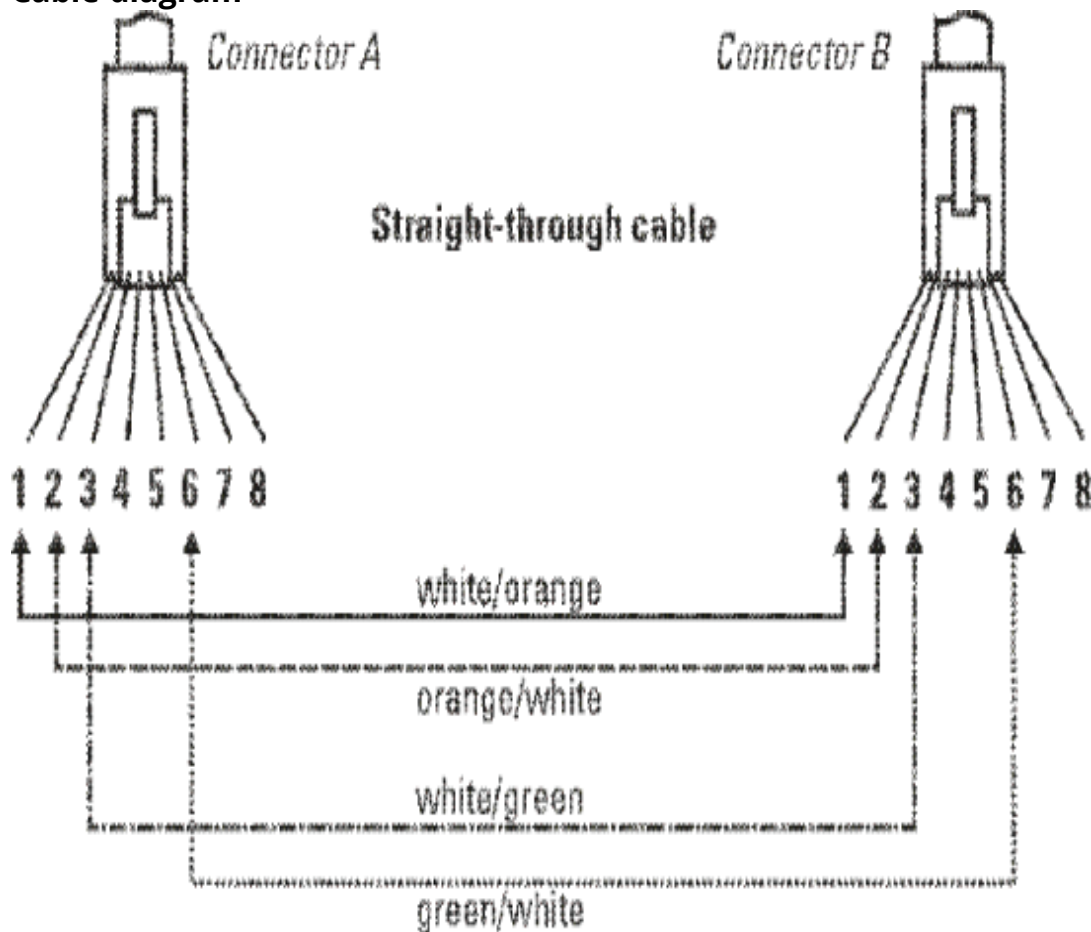



- Pins 1 and 2 on connector "A" must be wired as a twisted pair to pins 1 and 2 on connector "B".
- Pins 3 and 6 on connector "A" must be wired as a twisted pair to pins 3 and 6 on connector "B".
- Pins 4, 5, 7, and 8 are not used in this application, although they may be wired in the cable.

## Pin assignments

Switch end (MDI-X)		Hub or switch port, or other MDI-X port end	
Signal	Pins	Pins	Signal
receive +	1	6	transmit -
receive -	2	3	transmit +
transmit +	3	2	receive -
transmit -	6	1	receive +

## Straight-through twisted-pair cable for 1000 Mbps network connections

1000BASE-T connections require that all four pairs or wires be connected.

### Cable diagram

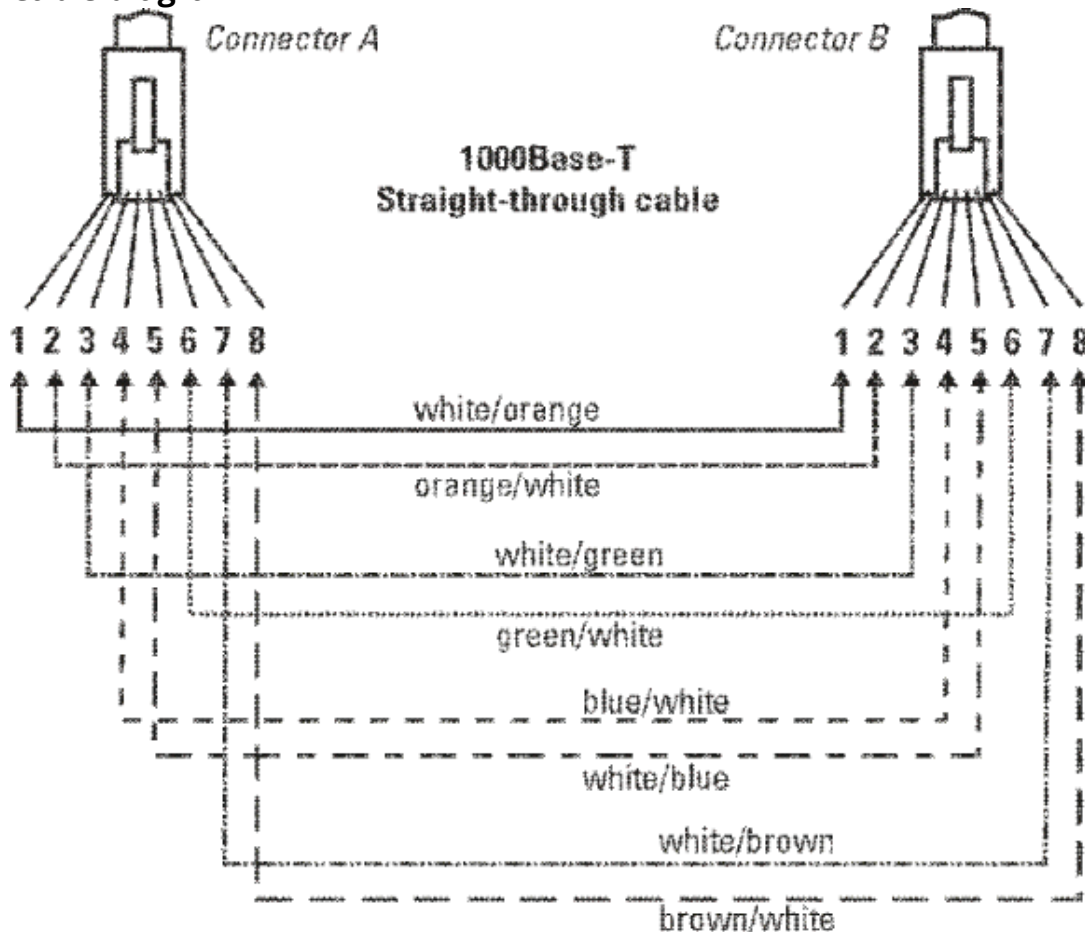



- 
- Pins 1 and 2 on connector "A" must be wired as a twisted pair to pins 1 and 2 on connector "B".
  - Pins 3 and 6 on connector "A" must be wired as a twisted pair to pins 3 and 6 on connector "B".
  - Pins 4 and 5 on connector "A" must be wired as a twisted pair to pins 4 and 5 on connector "B".
  - Pins 7 and 8 on connector "A" must be wired as a twisted pair to pins 7 and 8 on connector "B".
- 

## Pin assignments

For 1000BASE-T operation, all four pairs of wires are used for both transmit and receive.

Access Aruba support and updates, and view warranty and regulatory information

### Accessing Aruba Support

Aruba Support Services	<a href="https://www.arubanetworks.com/support-services/">https://www.arubanetworks.com/support-services/</a>
Aruba Support Portal	<a href="https://asp.arubanetworks.com/">https://asp.arubanetworks.com/</a>
North America telephone	1-800-943-4526 (US & Canada Toll-Free Number) +1-408-754-1200 (Primary - Toll Number) +1-650-385-6582 (Backup - Toll Number - Use only when all other numbers are not working)
International telephone	<a href="https://www.arubanetworks.com/support-services/contact-support/">https://www.arubanetworks.com/support-services/contact-support/</a>

Be sure to collect the following information before contacting Support:

- Technical support registration number (if applicable)
- Product name, model or version, and serial number
- Operating system name and version
- Firmware version
- Error messages
- Product-specific reports and logs
- Add-on products or components
- Third-party products or components

#### Other useful sites

Other websites that can be used to find information:

Airheads social forums and Knowledge Base	<a href="https://community.arubanetworks.com/">https://community.arubanetworks.com/</a>
Software licensing	<a href="https://lms.arubanetworks.com/">https://lms.arubanetworks.com/</a>
End-of-Life information	<a href="https://www.arubanetworks.com/support-services/end-of-life/">https://www.arubanetworks.com/support-services/end-of-life/</a>
Aruba software and documentation	<a href="https://asp.arubanetworks.com/downloads">https://asp.arubanetworks.com/downloads</a>

### Accessing Updates

You can access updates from the Aruba Support Portal or the HPE My Networking Website.

## Aruba Support Portal

<https://asp.arubanetworks.com/downloads>

If you are unable to find your product in the Aruba Support Portal, you may need to search My Networking, where older networking products can be found:

## My Networking

<https://www.hpe.com/networking/support>

To view and update your entitlements, and to link your contracts and warranties with your profile, go to the Hewlett Packard Enterprise Support Center **More Information on Access to Support Materials** page:

<https://support.hpe.com/portal/site/hpsc/aae/home/>

Access to some updates might require product entitlement when accessed through the Hewlett Packard Enterprise Support Center. You must have an HP Passport set up with relevant entitlements.

Some software products provide a mechanism for accessing software updates through the product interface. Review your product documentation to identify the recommended software update method.

To subscribe to eNewsletters and alerts:

<https://asp.arubanetworks.com/notifications/subscriptions> (requires an active Aruba Support Portal (ASP) account to manage subscriptions). Security notices are viewable without an ASP account.

## Warranty Information

To view warranty information for your product, go to <https://www.arubanetworks.com/support-services/product-warranties/>.

## Regulatory Information

To view the regulatory information for your product, view the *Safety and Compliance Information for Server, Storage, Power, Networking, and Rack Products*, available at <https://www.hpe.com/support/Safety-Compliance-EnterpriseProducts>

### Additional regulatory information

Aruba is committed to providing our customers with information about the chemical substances in our products as needed to comply with legal requirements, environmental data (company programs, product recycling, energy efficiency), and safety information and compliance data, (RoHS and WEEE). For more information, see <https://www.arubanetworks.com/company/about-us/environmental-citizenship/>.

## Documentation Feedback

Aruba is committed to providing documentation that meets your needs. To help us improve the documentation, send any errors, suggestions, or comments to Documentation Feedback ([docsfeedback-switching@hpe.com](mailto:docsfeedback-switching@hpe.com)). When submitting your feedback, include the document title, part number, edition, and publication date located on the front cover of the document. For online help content, include the product name, product version, help edition, and publication date located on the legal notices page.