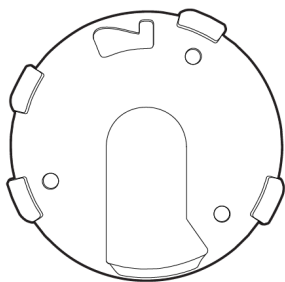
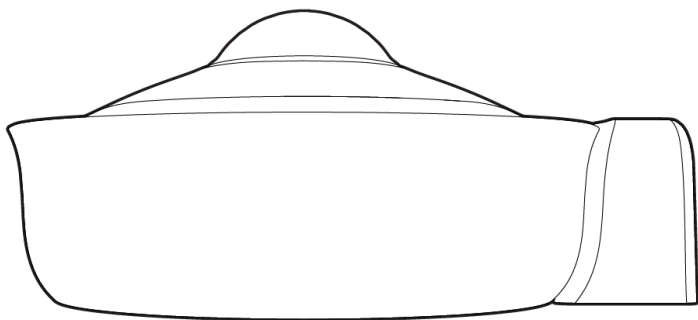

MV93 Installation Guide

MV93 Series Overview

The Cisco Meraki MV93 series MVs are the 3rd Generation network cameras that are exceptionally simple to deploy and configure due to their integration into the Meraki Dashboard and cloud-augmented edge storage. The MV family eliminates complex and costly servers and video recorders required by traditional solutions, removing the limitations on video surveillance deployments.

Package Contents:

In addition to the MV camera, the following are provided:



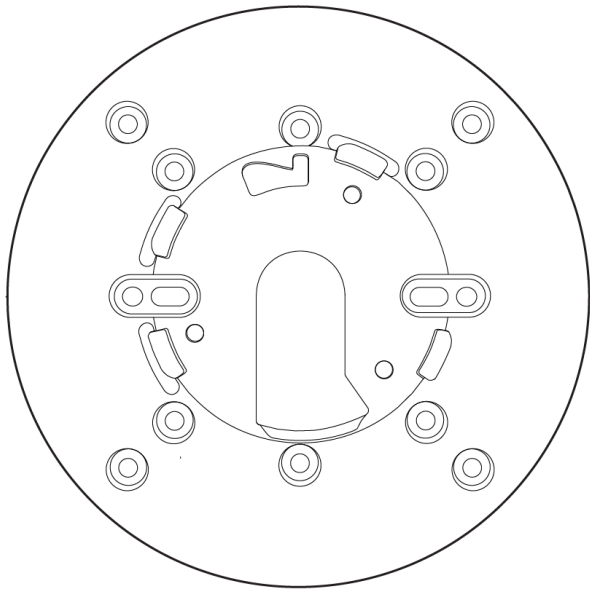
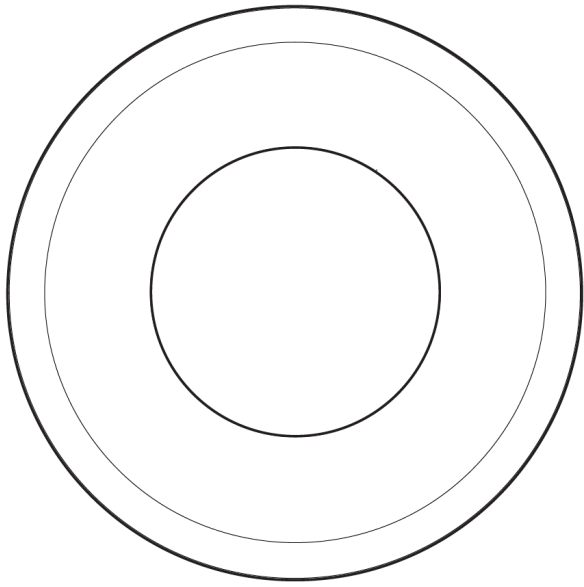

Unit	MV93-HW
	MV93X-HW
	4 x wall anchors
	4 x wall screws
Mounting Equipment	1 x base mount plate small
	1x base mount plate large
	1x Decorative cover
	1 x conduit adapter

Powering the MV93 Series

The MV93 features a 1000BASE-TX Ethernet port and requires 802.3at PoE+ minimally for operation. Route the Ethernet cable from an active port on a PoE switch or injector.

Note: Power over Ethernet supports a maximum cable length of 300 ft (100 m).

Pre-Install Preparation

You should complete the following steps before going on-site to perform an installation:

Configure Your Network in the Dashboard

The following is a brief overview of the steps required to add an MV93 series camera to your network. For detailed instructions about creating, configuring and managing Meraki Camera networks, refer to the online documentation (<https://documentation.meraki.com/MV>).

1. Login to <https://dashboard.meraki.com>. If this is your first time, create a new account.
 2. Find the network to which you plan to add your cameras or create a new network.
 3. Add your cameras to your network. You will need your Meraki order number (found on your invoice) or the serial number of each camera, which looks like Qxxx-xxxx-xxxx, and is found on the bottom of the unit.
 4. Verify that the camera is now listed under Cameras > Monitor > Cameras.
-

Check and Configure Firewall Settings

If a firewall is in place, it must allow outgoing connections on particular ports to IP addresses. The most current list of outbound ports and IP addresses for your organization can be found under **Help>Firewall Info** on the dashboard.

DNS Configuration Best practices for LAN Streaming

Each camera will generate a unique domain name for secured direct streaming functionality. These domain names resolve an A record for the private IP address of the camera. Any public recursive DNS server will resolve this domain.

If utilising an on-site DNS server, please whitelist *.devices.meraki.direct or configure a conditional forwarder so that local domains are not appended to *.devices.meraki.direct and that these domain requests are forwarded to Google public DNS.

Assigning IP Addresses

Currently, the MV93 series camera does not support static IP assignment. MV93 units must be added to a subnet that uses DHCP and has available DHCP addresses to operate correctly.

Installation Instructions

Note: During first-time setup, the MV93 series will automatically update to the latest stable firmware. Some features may be unavailable until this automatic update is completed. This process may take up to 5 minutes to enable whole disk encryption. The state of this process can be monitored by referencing the MV LED Status.

Mounting Instructions

For most mounting scenarios, the MV93 wall mount provides a quick, simple, and flexible means for mounting your device. The installation should be done in a few simple steps:

Note: Leave the protective plastic cover on the optical dome throughout the installation process to prevent any damage to the dome. The protective cover should be removed once the installation process is completed.

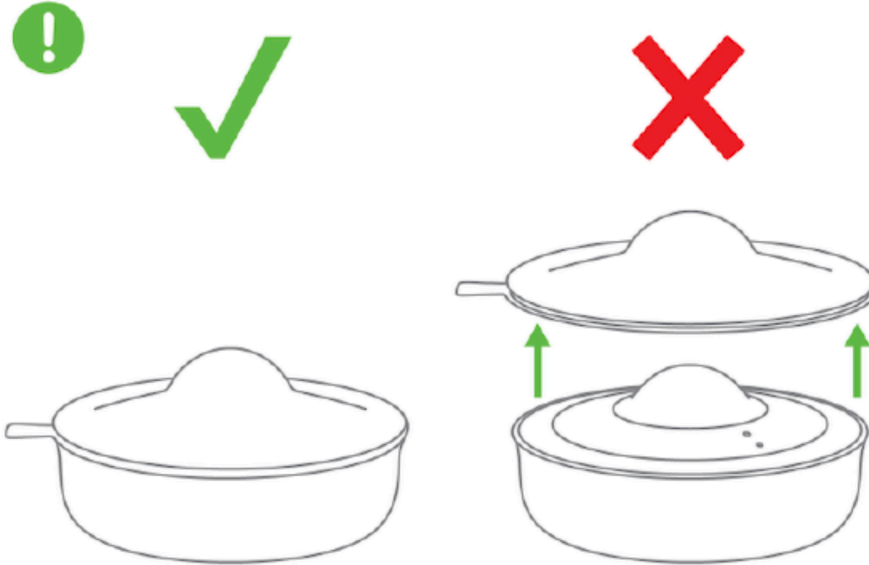

Microphone Cut-off Switch:

The MV63 Series has a new microphone cut-off switch at the camera's base. This switch can be used to disable audio and override the Dashboard Audio Settings for an added layer of security. If the regulations require disabling audio or Dashboard control for Audio enablement needs to be disabled, the microphone cut-off switch can be leveraged and set to Disabled.

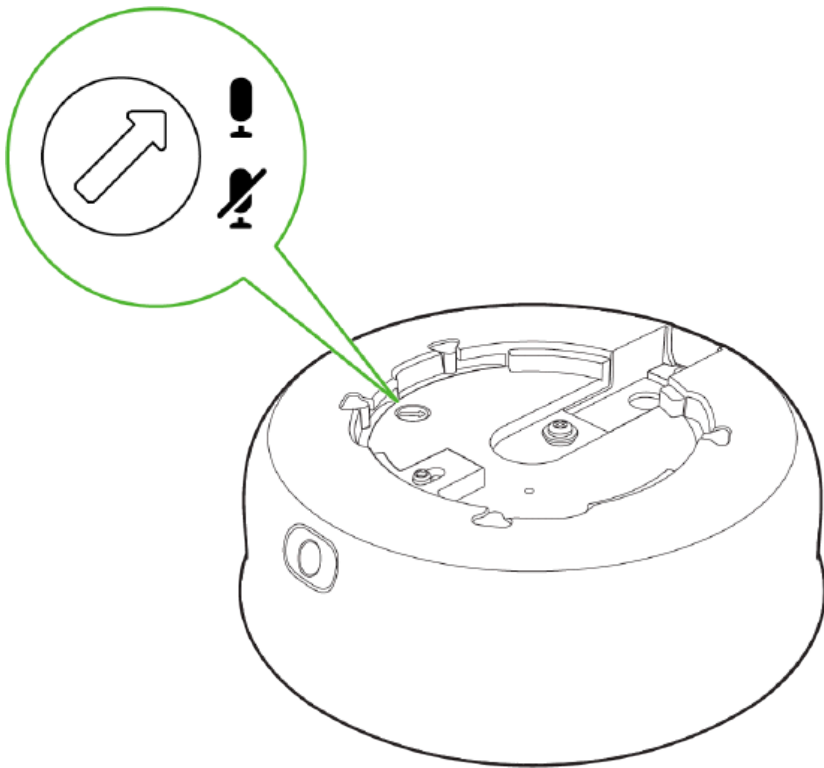

Note: If the microphone switch is disabled and the camera is mounted, toggling the switch back ON would require accessing the camera's base.

1. Use the template to determine mounting hole locations for wall mounting before screwing in the base mount plate. Peel backing from the mounting template to stick on the wall. Use template holes marked with the letter "A" for standard wall mounting. Screw the base mount plate onto the wall in pre-determined locations using the provided wall screws.

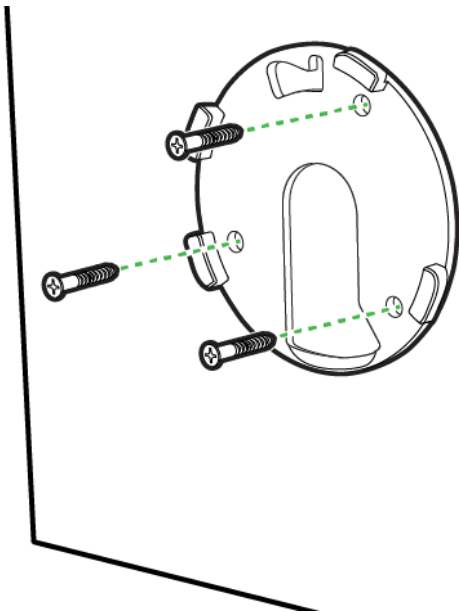

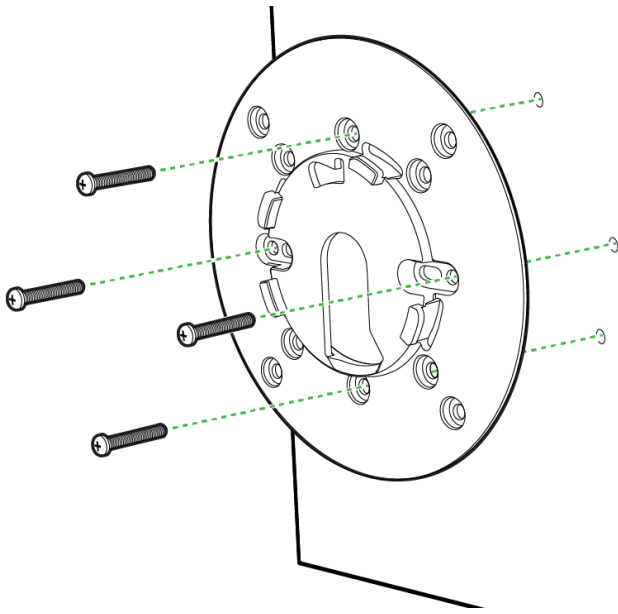

2. Follow this in-depth cable gland assembly guide to connect the PoE cable to the camera cable gland and ensure the seal is water-tight. This step is very important and may damage the camera if done improperly.

Note: If installing external conduit terminated at the camera, ensure the camera conduit adapter and terminal adapter are pulled over the camera pigtail before making the connection to avoid the risk of water damage leading to hardware failure and warranty void.

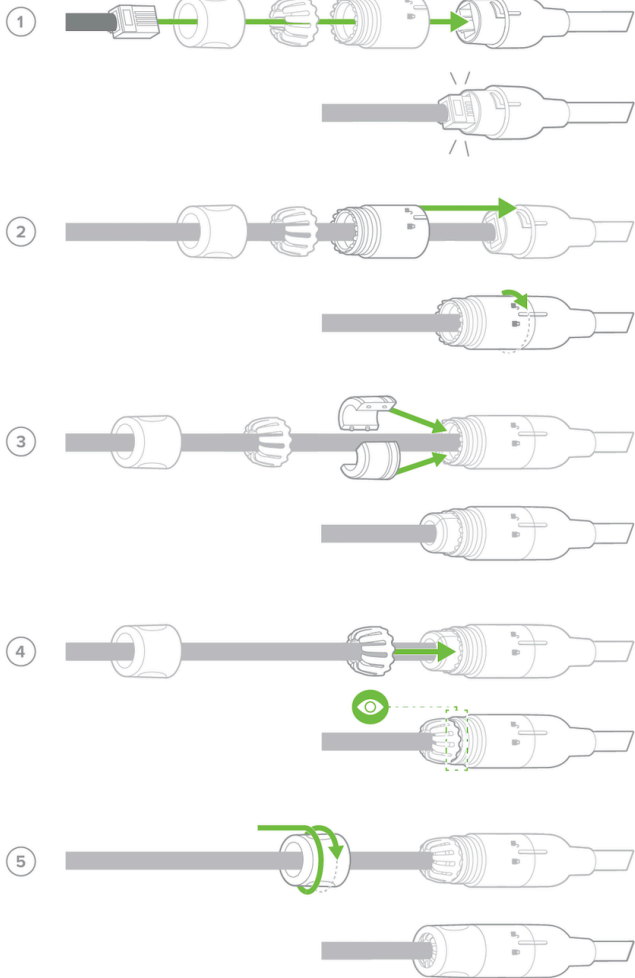
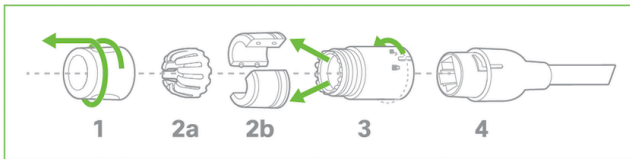

2. If using a conduit adapter, attach the terminal adapter to the conduit adapter. Route the conduit over the water-tight cable gland assembly and terminate at the terminal adapter. Ensure the camera conduit adapter is securely placed on the base mount plate as pictured.

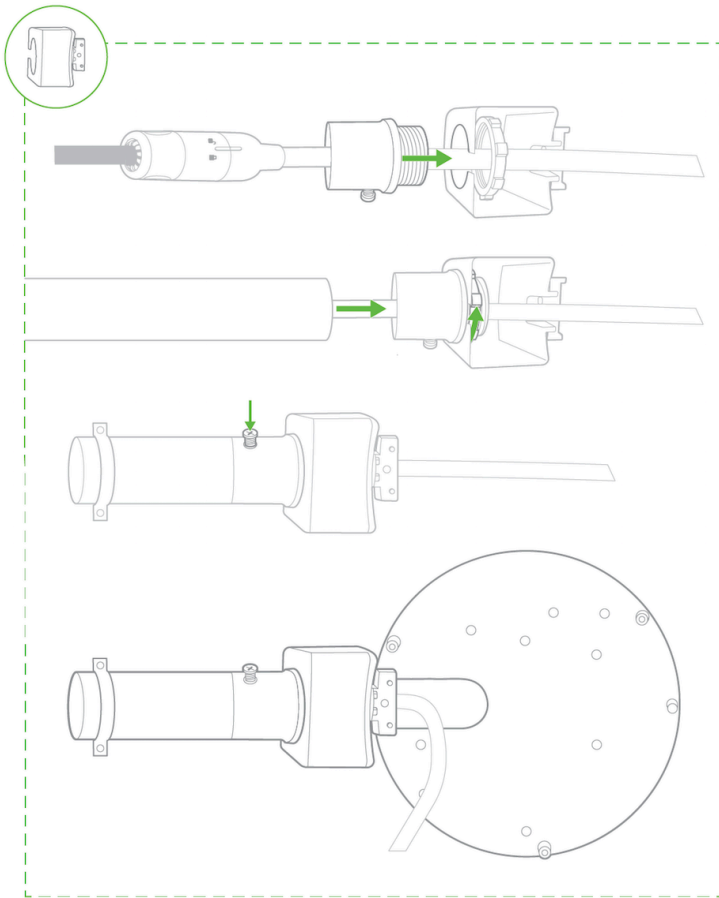

Installing the conduit box to MV93 series: (optional)

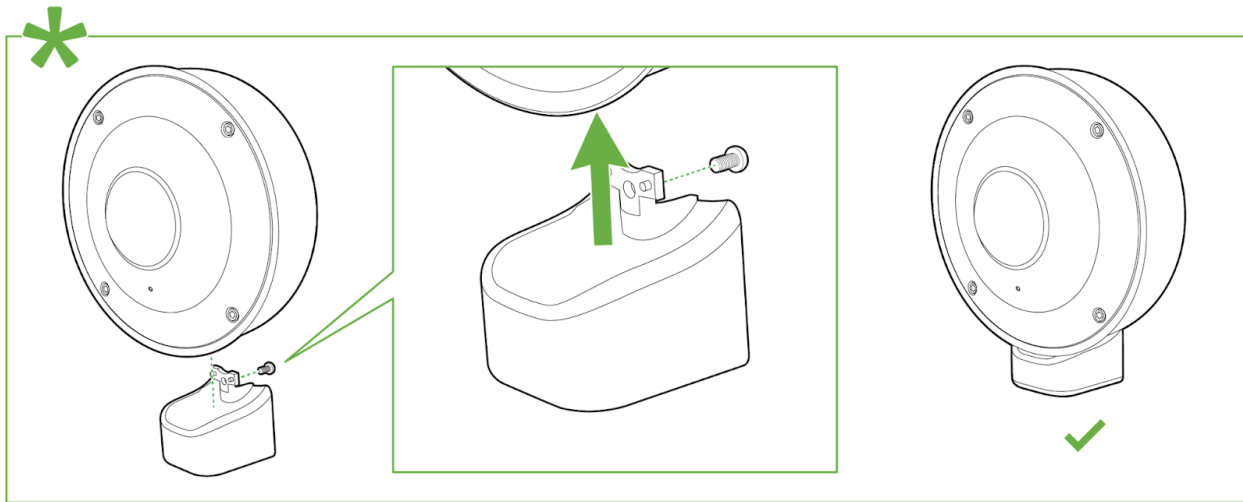

3. MV63 series comes with two base mount plates, a small plate and a large plate. The functionality of both plates is identical. Please refer to the guidelines below on using the base plate mounting to any surface or on top of a mounting accessory.

MV93 Mount using small base plate:

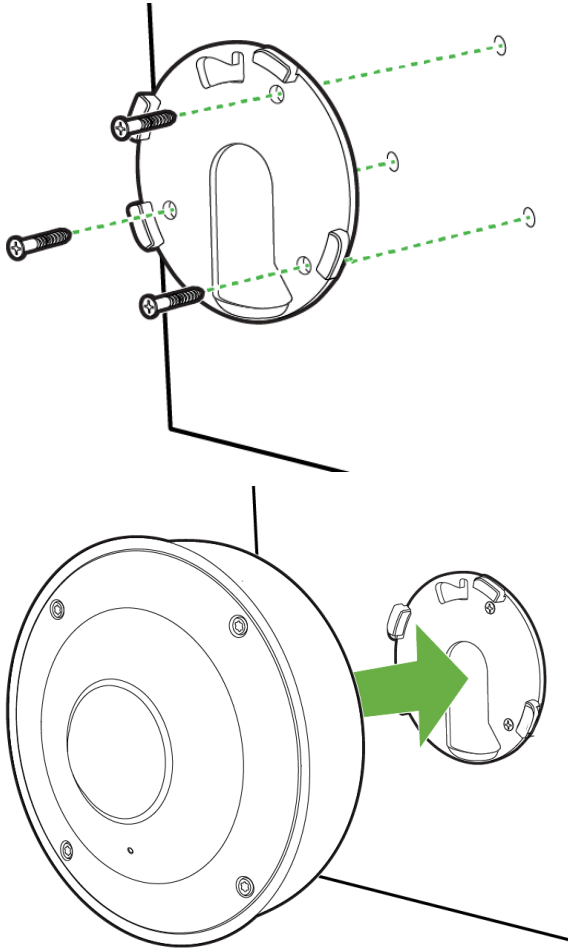

- Mount the small base plate onto the wall surface using the paper template provided.
- Use 3x Wall anchor and screws to fix the base plate to the wall.
- The MV93 Series cameras have a button to engage the locking mechanism. Press the button while aligning the MV93 series to the small base plate.

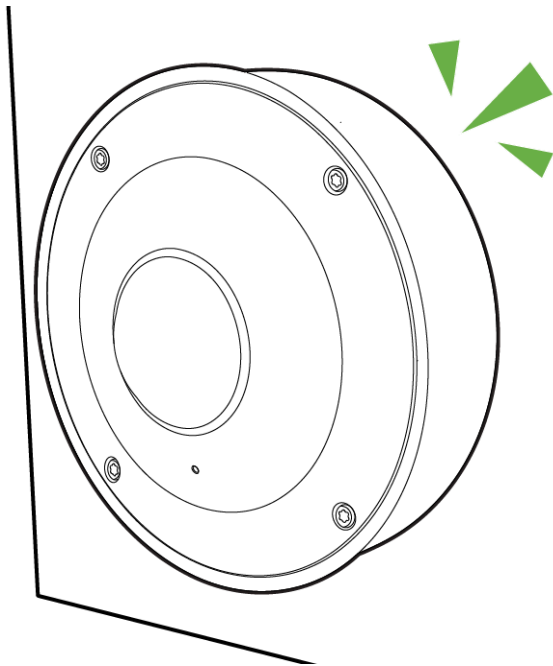
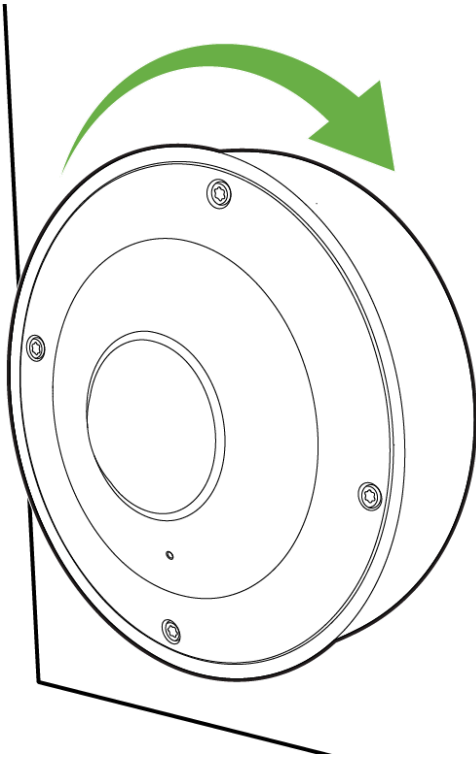

- Twist the camera while holding the button until a click is heard.
- The camera is locked onto the plate and secured.

MV93 Mount using large base plate:

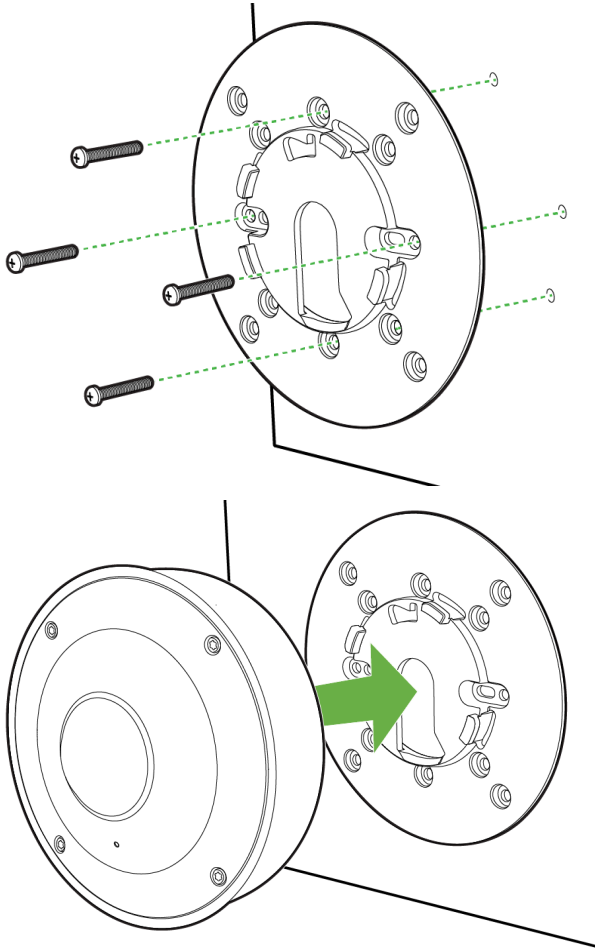

- Mount the large base plate onto the wall surface using the paper template provided.
- Use 4x Wall anchor and screws to fix the base plate to the wall.
- The MV93 Series cameras have a button to engage the locking mechanism. Press the button while aligning the MV93 series to the large base plate.

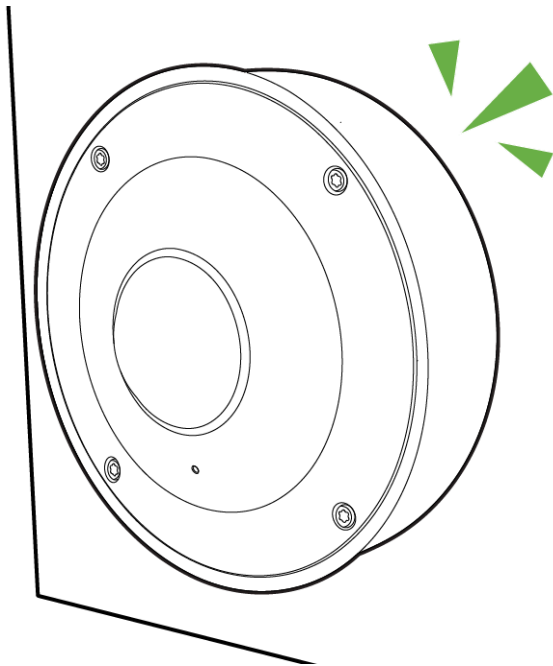
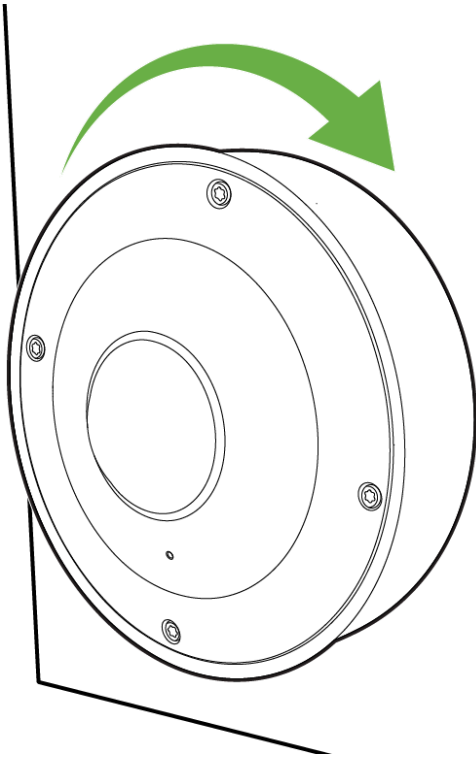

- Twist the camera while holding the button until a click is heard.
- The camera is locked onto the plate and secured.

MV93 Mount using large base plate and Decorative Cover:

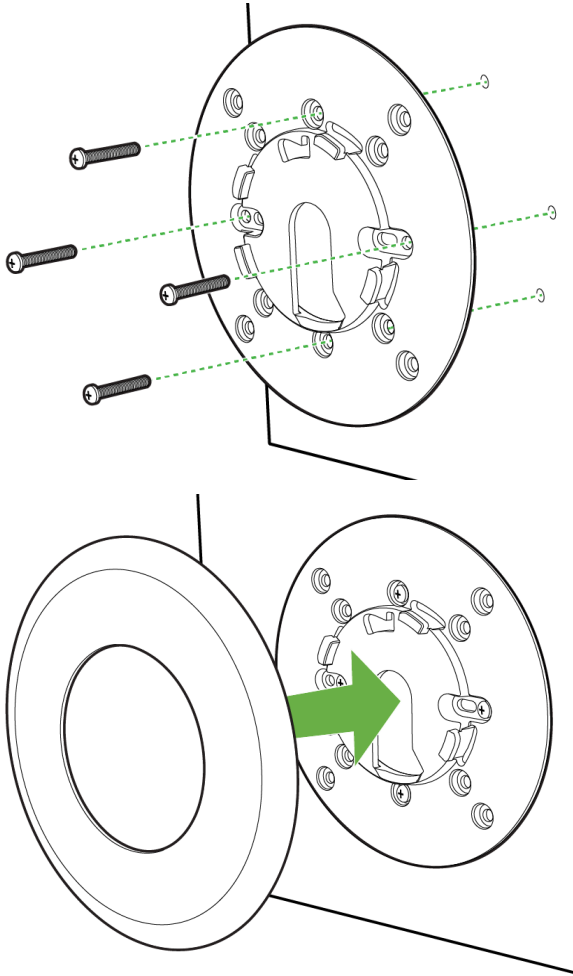

- Mount the large base plate onto the wall surface using the paper template provided.
- Use 4x Wall anchor and screws to fix the base plate to the wall.
- Place the decorative cover on top of the large base plate and press the cover against the plate. You will hear a click as the decorative cover is secured.

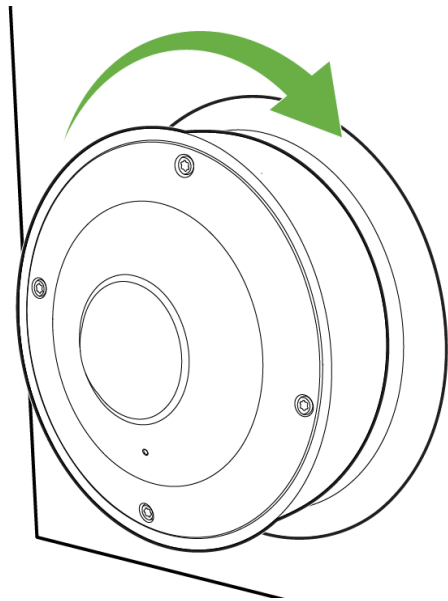
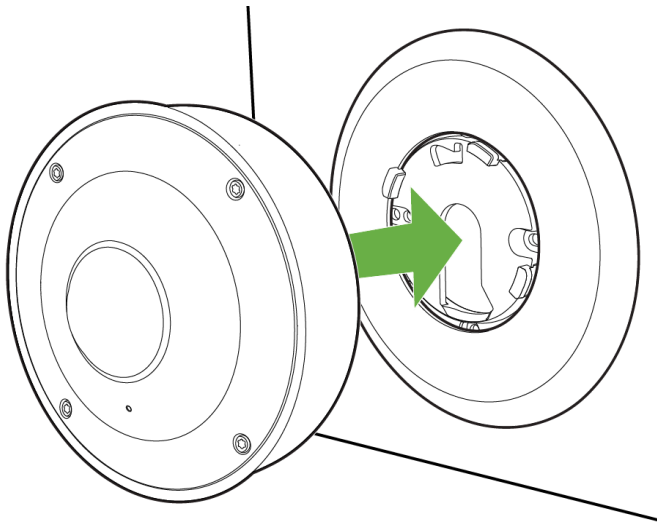

- The MV93 series cameras have a button to engage the locking mechanism. Press the button while aligning the MV93 series to the small base plate.
- Twist the camera while holding the button until a click is heard.

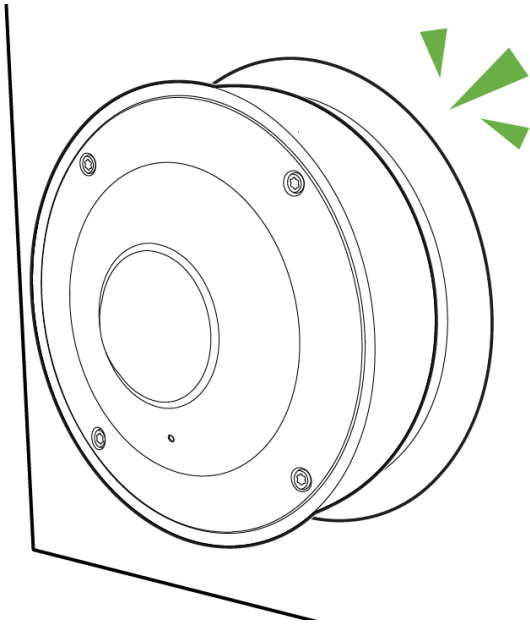

- The camera is locked onto the plate and secured.

4. Once completed, twist and lock the camera to the base plate. A click is heard when the camera is locked in place.

Remove the protective cover when the installation is complete.















5. Observe the status LED on the left side of the camera lens assembly and ensure the camera is connected via Ethernet (solid green) or WiFi (solid blue). An MV must first be provisioned over a wired Ethernet connection before it can be deployed wirelessly. See the setup guide here for information on how to connect via WiFi.

MV93 LED Status Indicator



Your MV93 series is equipped with an LED light on the front of the unit to convey system functionality and performance information.

The following colours and patterns indicate the various status conditions of an MV:

- Rainbow (solid, rotating through colours) - MV is booting up.
- Flashing Blue - MV is searching for WiFi network(s).
- Flashing Green - MV is upgrading or initialising for the first time.
- Solid Green - MV is connected via Ethernet.
- Solid Blue - MV is connected via WiFi.
- Solid Violet - MV has audio recording enabled.
- Solid Amber - MV is not able to connect to the Dashboard.

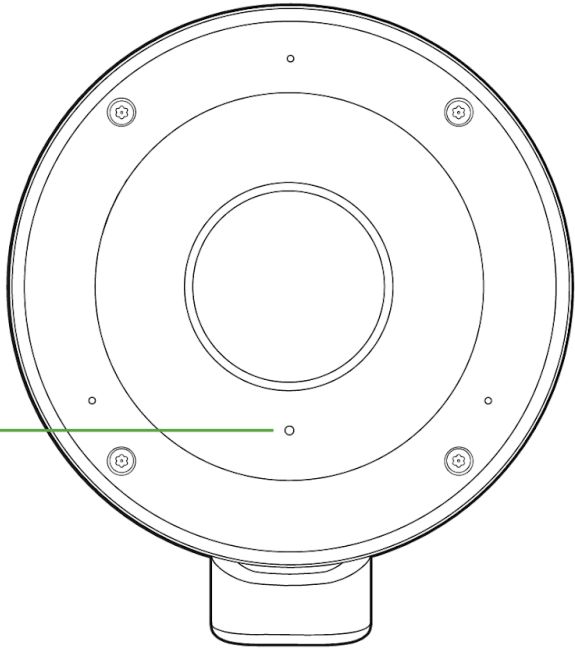

 dashboard.meraki.com
 docs.meraki.com/mv