

IOWA

TRAVEL PARTY MANUAL





TABLE OF CONTENTS

TEAM ITINERARY	2

PRE-TRAVEL INFORMATION / TRANSPORTATION	11

HOTEL INFORMATION	15

PER DIEM	18

PLAYER TICKET INFORMATION	19

PLAYER BOWL GIFTS	20

FAMILY PRE-TRAVEL CHECKLIST	22

FAMILY / TRAVEL PARTY ITINERARY	23

BOWL EVENTS	28

VIP HOSPITALITY (STAFF & FAMILY SUITE)	32

HOTEL AMENITIES / DINING	33

ORLANDO INFORMATION	34

GAME DAY / CAMPING WORLD STADIUM INFORMATION	41



TEAM ITINERARY

EARLY LUGGAGE DROP-OFF

MONDAY, DECEMBER 20, 2021

3:00-5:00 pm Early Luggage Drop Off - HFPC Loading Dock

TUESDAY, DECEMBER 21, 2021

12:00-5:00 pm Early Luggage Drop Off - HFPC Loading Dock

6:00 pm Truck Departs Loading Dock for Orlando, FL

2

LAST MINUTE LUGGAGE DROP-OFF

SATURDAY, DECEMBER 25, 2021

1:00-5:00 pm Last Minute Luggage Drop Off - HFPC Loading Dock

SUNDAY, DECEMBER 26, 2021

7:00-9:00 am Last Minute Luggage Drop Off - HFPC Loading Dock

9:15 am Luggage Truck Departs



SUNDAY, DECEMBER 26, 2021

DEPARTURE DAY / PLAYER WELCOME MEAL

8:00-10:00 am Players' Breakfast – HFPC

8:30 am Bus 8 Departs Finkbine South Parking Lot

8:45 am Bus 7 Departs Finkbine South Parking Lot

9:00 am Bus 6 Departs Finkbine South Parking Lot

9:15 am Bus 5 Departs Finkbine South Parking Lot

9:30 am Bus 4 Departs Finkbine South Parking Lot

9:15 am ***Airplane Luggage Truck Departs – HFPC Loading Dock***

10:00 am Bus 3 Departs Finkbine South Parking Lot

10:15 am Bus 2 Departs Finkbine South Parking Lot

10:30 am Bus 1 Departs Finkbine South Parking Lot

11:30 am **Team Charter Departs Cedar Rapids, IA**

3:15 pm (EST) **Team Charter Arrives – Orlando, FL**

SET WATCHES FORWARD 1 HOUR

5:00 pm Team Meeting – Florida Ballroom A – Conference Level

5:30 pm Player Welcome Party – Orlando Ballroom LMN

**Players and FB Staff Only – No Children or Spouses*

10:00-11:30 pm Players' Snack – Plaza Int'l Ballroom G

12:00 am LIGHTS OUT



MONDAY, DECEMBER 27, 2021

PRACTICE & LIFT

6:45-8:15 am	Taping & Treatments - Florida Ballroom C
6:45-8:15 am	Players' Breakfast - Plaza Int'l Ballroom G
7:15 am	Staff Meeting - Challenger 41-42 (Third Level)
8:00-8:25 am	Special Teams Meeting - Florida Ballroom A
8:10 am	Minutemen Departs Hyatt for Practice
8:30-9:00 am	Position Meetings
9:10 am	Buses Depart Hyatt for Practice/Lift
9:30 am	2 Deep Lift Pre-Practice
10:50 am	Practice - West Orange High School
12:00 pm	Buses Begin Returning to Hyatt On-Flow
12:20-2:00 pm	Players' Lunch - Plaza Int'l Ballroom G
4:30-5:00 pm	Team Meeting - Florida Ballroom A
5:00-6:05 pm	Position Meetings
5:30-6:45 pm	Players' Dinner - Plaza Int'l Ballroom G
5:45 pm	2 Buses Depart for SeaWorld Orlando (OPTIONAL) <ul style="list-style-type: none">• Dress: Casual• Player and Student Staff
6:30 pm	2 Buses Depart for SeaWorld Orlando (OPTIONAL) <ul style="list-style-type: none">• Dress: Casual• Player and Student Staff• 4 Buses Return at 9:30 pm
6:30-11:15 pm	Players' Free Time - Walk/Uber/Lyft
10:00-11:30 pm	Players' Snack - Plaza Int'l Ballroom G
12:00 am	LIGHTS OUT



TUESDAY, DECEMBER 28, 2021

PRACTICE / ORLANDO MAGIC GAME

6:45-8:15 am	Taping & Treatments - Florida Ballroom C
6:45-8:15 am	Players' Breakfast - Plaza Int'l Ballroom G
7:15 am	Staff Meeting - Challenger 41-42
7:50 am	Minutemen Depart Hyatt for Practice/Lift
8:00-8:25 am	Special Teams Meeting - Florida Ballroom A
8:30-9:00 am	Position Meetings
9:10 am	Buses Depart Hyatt for Practice
10:20 am	Practice - West Orange High School
Post-Practice	Specialists Lift
12:00 pm	Buses Begin Returning to Hyatt On-Flow
12:20-2:00 pm	Players' Lunch - Plaza Int'l Ballroom G
4:00-5:05 pm	Position Meetings
4:30-5:45 pm	Players' Dinner - Plaza Int'l Ballroom G
5:00-11:15 pm	Players' Free Time - /Walk/Uber/Lyft
6:15 pm	Buses Depart for Orlando Magic Game
7:00 pm	Orlando Magic vs. Milwaukee Bucks <ul style="list-style-type: none">• Dress: Casual• Players Only Event - OPTIONAL
10:00-11:30 pm	Players' Snack - Plaza Int'l Ballroom G
12:00 am	LIGHTS OUT



WEDNESDAY, DECEMBER 29, 2021

PRACTICE/LIFT/TOP GOLF EVENT

7:45-9:00 am	Taping & Treatments - Florida Ballroom C
7:45-9:00 am	Players' Breakfast - Plaza Int'l Ballroom G
7:45 am	Staff Meeting - Challenger 41-42
8:15 am	Cars Leave Hyatt for Press Conference at Rosen Plaza Hotel
8:30 am	Select Players & Coordinators Press Conference - Rosen Plaza
	<ul style="list-style-type: none">• Players: Travel Sweats w/Numbers or Jerseys• Coordinators: Polo
8:40-9:10 am	Special Teams Meeting - Florida Ballroom A
9:15-9:45 am	Position Meetings
9:30 am	Minutemen Bus Departs Hyatt for Practice
9:55 am	Buses Depart Hyatt for Practice
10:40 am	Practice - West Orange High School
Post-Practice	Lift Group
12:30 pm	Buses Begin Departing for Hotel ON-FLOW
1:00-3:00 pm	Players' Lunch - Plaza Int'l Ballroom G
4:45 pm	Team Meeting - Florida Ballroom A
5:00-6:00 pm	Position Meetings
5:30-7:00 pm	Players' Dinner - Plaza Int'l Ballroom G
7:40 pm	Buses Depart Hyatt for Top Golf
8:00-10:00 pm	Players' Outing - Top Golf Orlando
	<ul style="list-style-type: none">• <i>Players & Student Staff Only Event</i>• Required: Players• Dress: Casual
10:15-11:30 pm	Players' Snack - Plaza Int'l Ballroom G
12:00 am	LIGHTS OUT



THURSDAY, DECEMBER 30, 2021

FCA BREAKFAST/DAY FOR KIDS/UNIVERSAL ORLANDO

6:45 am	Bus/s Depart Hyatt for FCA Breakfast
7:00-8:30 am	FCA Breakfast - First Baptist Church Faith Hall <ul style="list-style-type: none">• Optional for Players• Guest Speaker: Lou Holtz• Dress: TBD
7:45-8:30 am	Players' Breakfast for those not attending FCA
8:40 am	Buses Depart for Day for Kids
9:00-11:00 am	Day for Kids Event - Fun Spot America Theme Park <ul style="list-style-type: none">• <i>Required: Players, Coaches & SID</i>• Dress: Warm-Ups with Number Displayed• Will be given Light Lunch Box for Return Ride
11:30-1:00 pm	Players' Lunch - Plaza Int'l Ballroom G
2:00 pm	Buses Depart for Universal Orlando
2:30-8:30 pm	Universal Orlando Resort - Team Event <ul style="list-style-type: none">• Dress: Warm-Ups with Number Displayed• Dinner Per Diem: \$20 (Placed on Per Diem Card)• Express Pass Provided for Players & Student Staff• Bus Return Times: 5:30/7:00/8:30 pm
5:30-10:30 pm	Players' Free Time - Walk/Uber/Lyft
9:30-11:00 pm	Players' Snack - Plaza Int'l Ballroom G
11:00 pm	LIGHTS OUT



FRIDAY, DECEMBER 31, 2021

PRACTICE / PICTURE DAY

7:45-8:45 am	Taping & Treatments – Florida Ballroom C
7:45-8:45 am	Players’ Breakfast – Plaza Int’l Ballroom G
8:15 am	<i>Car Departs Hyatt for Head Coach Press Conference</i>
8:30-9:15 am	<i>Head Coaches Press Conference – Rosen Plaza Hotel</i> <ul style="list-style-type: none">• Dress: Coat & Tie
8:50-9:00 am	Special Teams Meeting – Florida Ballroom A
9:05-9:35 am	Position Meetings
9:15 am	Minutemen Bus Departs Hyatt for Practice
9:45 am	Buses Depart Hyatt for Practice
10:10 am	Primer
10:30 am	Practice – West Orange High School
11:30 am	Player Bags to Equipment Truck – Vacate Practice Site
12:15-1:30 pm	Players’ Lunch – Plaza Int’l Ballroom G
1:40-2:25 pm	Position Meetings
2:45 pm	Buses Depart Hyatt for Stadium Team Picture <ul style="list-style-type: none">• <i>Those Traveling to Breakout Hotel: Bring Luggage Needed</i>
3:00 pm	Family Bus Departs Hotel for Stadium Team Picture
3:20 pm	Team and Family Photos at Stadium
4:00 pm	Travel Roster and Staff Depart Stadium for Breakout Hotel <ul style="list-style-type: none">• Buses 1-3
4:00 pm	Minutemen & Staff return to Hyatt Regency
	<i>*Below Schedule is for Players staying at the Hyatt Regency</i>
5:30-6:30 pm	Minutemen Dinner – Plaza Int’l Ballroom G
9:00-10:00 pm	Minutemen Snack – Plaza Int’l Ballroom G
11:00 pm	LIGHTS OUT



SATURDAY, JANUARY 1, 2022
BEAT KENTUCKY

**Schedule for Players/Staff staying at Hyatt Regency*

7:00 am	Early Stadium Crew Meal
7:40 am	Early Crew Departs for Stadium
9:00-10:00 am	Pregame Meal - Plaza Int'l Ballroom G
10:00 am	Bags entering Stadium - K9
10:45 am	Minutemen and Family Buses Depart Hyatt for Stadium <ul style="list-style-type: none">• Minutemen & Football Staff (Please See Bus List)
1:06 pm	BEAT KENTUCKY – BRING TROPHY HOME
4:30 pm	Player Post Game Media
4:50 pm	Team Buses begin Returning to Hyatt ON-FLOW
7:30-9:00 pm	Luggage Ready for Return Trip can be Brought down <ul style="list-style-type: none">• Place in Plaza Int'l Ballroom D-F• Place in Corresponding Line (See Signs)

**Dinner Per Diem*



SUNDAY, JANUARY 2, 2022

DEPARTURE DAY

TBA	Player Airport Shuttle
TBA	Player Airport Shuttle
6:30 am	<i>Team Semi & Airplane Box Truck Ready for Loading - Service Road</i>
7:15-9:15 am	Travel Party Breakfast - TBA
8:00 am	Bus 7 Departs Hyatt for Airport
8:15 am	Bus 6 Departs Hyatt for Airport
8:30 am	<i>AIRPLANE LUGGAGE TRUCK Departs Hyatt for Charter</i>
8:30 am	Bus 5 Departs Hyatt for Airport
8:45 am	Bus 4 Departs Hyatt for Airport
9:00 am	Bus 3 Departs Hyatt for Airport
9:15 am	Bus 2 Departs Hyatt for Airport
9:30 am	Bus 1 Departs Hyatt for Airport
10:30 am	Charter Departs Orlando, FL

10

SET WATCHES BACK 1 HOUR

12:30 pm	Charter Lands Cedar Rapids, IA
1:15 pm	Buses Arrive - Finkbine
TBA	Luggage Dropped Off at Hansen Football Performance Center <ul style="list-style-type: none">• Ben Hansen will send out a text when luggage is ready.



PRE-TRAVEL INFORMATION

PACKING

Forecasts predict temperatures in the mid to high 70's & Low 80's during our time in Orlando with lows in the mid 60's. Please pack accordingly and bring clothes for evening activities. If you RSVP for certain events, please check the dress attire prior to packing.

LUGGAGE

December 20th - Early Luggage Drop Off (3:00 PM - 5:00 PM)

December 21st - Early Luggage Drop Off (12:00 PM-5:00 PM)

December 21st - Truck Departs at 6:00 PM

PER DIEM

		B	L	D
Staff Member	\$69	13.80	20.70	34.50
Adults	\$40	8	12	20
Age 13+	\$30	6	9	15
Age 1-12	\$20	4	6	10

PARKING

Please see map on following page in regards to where to park at Finkbine Golf Course. **THERE WILL NOT BE PARKING AVAILABLE AT AIRPORT. PLEASE TAKE THE BUSES OR GET DROPPED OFF.** We strongly recommend that you remove all items of value from your vehicles while we are in Orlando. Recommend turning windshield wipers off and pulling windshield wipers up due to ice accumulation while we are gone.

BUS / PLANE ASSIGNMENTS

Bus and plane assignments will be distributed via text and posted in Loading Dock of Hansen Football Performance Center. If you have children, please make sure you check Bus and Plane assignments for them at the Loading Dock. We will also send out a text with their assignments.

MASK REQUIRED FOR PLANE

PHOTO ID OR PASSPORT

You are required to bring a photo ID or Passport.



DEPARTURE DAY PARKING

You may park your car in the Finkbine Golf Course Parking Lot prior to our departure. (See Map Below).



Citrus Bowl Parking Areas
Finkbine Lot and Athletic Club Lot (12/26 – 1/2)



TRANSPORTATION INFORMATION – CITRUS BOWL

COURTESY/RENTAL VEHICLE INFORMATION & PROCEDURES Citrus Bowl

Courtesy and rental vehicles for the Citrus Bowl will be coordinated by Associate Athletic Director- Damian Simcox and Football Operations- Paul Federici/Ben Hansen. Please see contact information below.

- Damian Simcox 319-631-2552
- Paul Federici 319-430-6356
- Ben Hansen 319-425-1825

General Information for Staff Courtesy and/or Rental Vehicles

- All vehicles will be valet parked by the Hyatt Regency Orlando staff. You will be given a valet slip in your check-in envelope, that you will be responsible for during your entire stay and are required to return to Damian Simcox upon your final use of the vehicle.
- It is recommended that you take a photo of your valet slip to ensure that you remember your valet number.
- Vehicles may only be driven by Iowa staff members and spouses over 25 years of age. All drivers must submit a copy of their driver's license and current insurance card- if not a University of Iowa employee. Please send to either Paul Federici/Ben Hansen- Football or Damian Simcox- Administration, 5 days prior to departure, so we can confirm registration through the University driving approval process (for university employees).
- Some individuals may be assigned to Citrus Bowl courtesy vehicles, which will require additional approval. I will reach out separately to get their information sooner.
- Individuals who are assigned a vehicle, will be responsible for that vehicle, and required to maintain it during their stay. Any mechanical problems, accidents, tickets, etc. must be reported immediately to Damian Simcox.
 - Staff members are responsible for any tolls
 - Bring any gas receipts for reimbursements at time of vehicle return.
 - **Please return vehicles full, at that time.**
 - Remember to tip valet staff- on your own

NOTE: Valet ticket must be turned in to Damian Simcox on January 1st at 10:00pm at the Valet Desk or call to make final arrangements to check in your vehicle.



ATHLETIC ADMINISTRATION POOL VEHICLES

Athletic Administration Pool Vehicles

- Vehicles may be checked out from the Administrative Office, beginning on December 26th at 5:00pm
 - Valet slips are in envelopes- all vehicles are parked in the hotel valet. Upon return, please place valet slip to the proper envelope in the Administration Office. If after hours- contact Damian Simcox to make arrangements for the vehicle return.
 - Remember to tip valet staff- on your own.
- Work functions/activities have priority for these vehicles. Please submit requests as early as possible and have vehicles returned for pre-scheduled times.
- Vehicles may only be driven by Iowa staff members and spouses over 25 years of age. All drivers must submit a copy of their driver's license and current insurance. Please send to Damian Simcox, 5 days prior to departure, so that we can confirm registration through the University driving approval process (for university employees).
- Individuals who check out vehicles, will be responsible for that vehicle during their use. Please report any mechanical problems, accidents, tickets, etc. immediately to Damian Simcox.
 - Staff members are responsible for any tolls
 - Please bring any gas receipts to Administrative Office, for reimbursements at time of vehicle check-in.
 - Vehicles should be returned full, after each use.

NOTE: All Pool Vehicles shall be returned to the Administrative Office by 9:00pm on January 1st or contact Damian Simcox to make final arrangements to return the vehicle.



HOTEL INFORMATION

Hyatt Regency Orlando is located centrally on the International Drive corridor, giving you easy access to shopping, dining, and all of the best things to do in Orlando—including downtown Orlando and major theme parks. On-site, enjoy pool deck activities and cabana rentals.



15

HYATT REGENCY ORLANDO

9801 International Dr.

Orlando, FL 32819

Phone: [\(844\) 202-8766](tel:8442028766)

WiFi Information

Guestroom Network: Select WIFI option

Password: Enter Last Name and Room Number / Select Basic Internet

Staff Hospitality Room: Orchid Room

Administration Office: Rock Spring

Football Admin Office: Boardroom / Columbia 34





PLAYER HOSPITALITY SUITE

LOCATION: Orlando Ballroom LMN

Hours:

SUNDAY, DECEMBER 26 TH	5:30-11:30 PM
MONDAY, DECEMBER 27 TH	1:00-11:30 PM
TUESDAY, DECEMBER 28 TH	1:00-11:30 PM
WEDNESDAY, DECEMBER 29 TH	2:30-11:30 PM
THURSDAY, DECEMBER 30 TH	1:00-11:00 PM
FRIDAY, DECEMBER 31 ST	4:30-10:00 PM
SATURDAY, JANUARY 1 ST	5:00 PM - 1:00 AM

16

The Player Hospitality Suite is for **PLAYERS AND STUDENT WORKERS ONLY!**

Refreshments available inside the Player Hospitality Suite



HYATT REGENCY-ORLANDO - CONFERENCE LEVEL

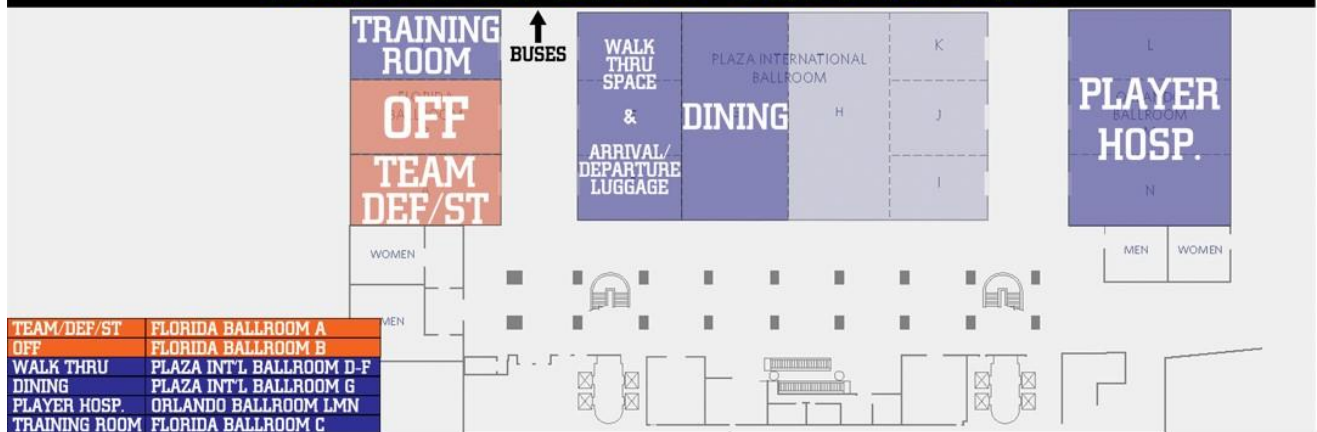

TEAM/DEF/ST	FLORIDA BALLROOM A
OFF	FLORIDA BALLROOM B
WALK THRU	PLAZA INT'L BALLROOM D-F
DINING	PLAZA INT'L BALLROOM G
PLAYER HOSP.	ORLANDO BALLROOM LMN
TRAINING ROOM	FLORIDA BALLROOM C

HYATT REGENCY-ORLANDO - THIRD LEVEL

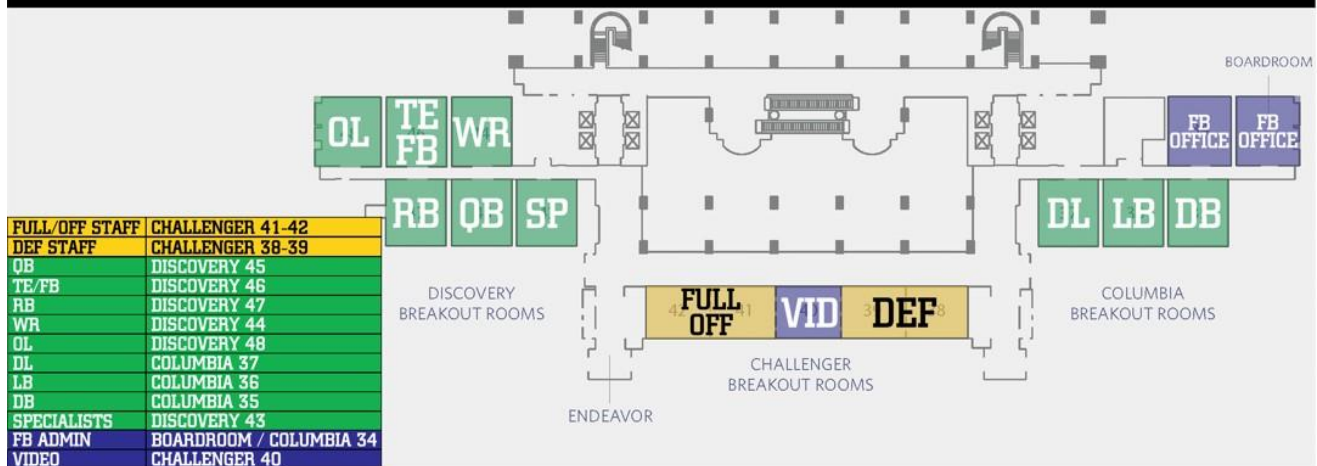

FULL/OFF STAFF	CHALLENGER 41-42
DEF STAFF	CHALLENGER 38-39
QB	DISCOVERY 45
TE/FB	DISCOVERY 46
RB	DISCOVERY 47
WR	DISCOVERY 44
OL	DISCOVERY 48
DL	COLUMBIA 37
LB	COLUMBIA 36
DB	COLUMBIA 35
SPECIALISTS	DISCOVERY 43
FB ADMIN	BOARDROOM / COLUMBIA 34
VIDEO	CHALLENGER 40



FLOOR 4

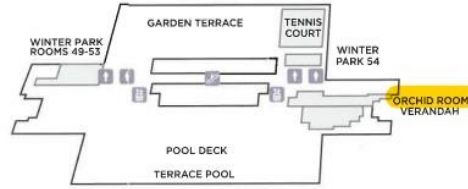

FLOOR 3

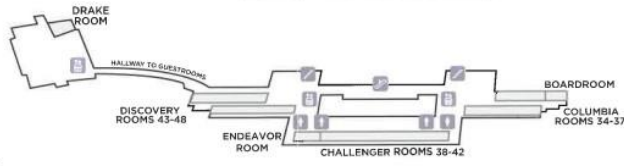

LOBBY

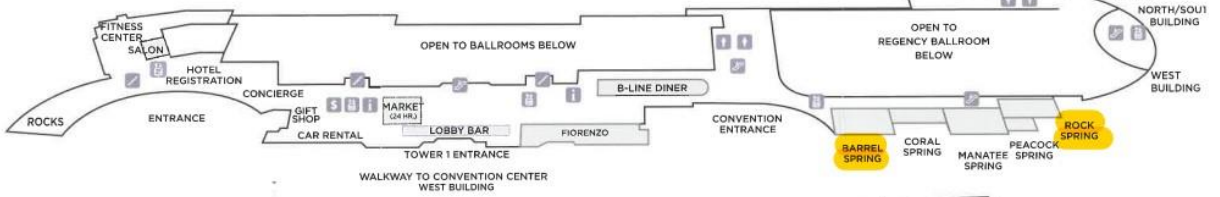

FLOOR 1



CONVENTION LEVEL



KEY

- Restrooms
- Escalator
- Stairway
- Elevator
- Information
- ATM



TEAM MEALS / PLAYER PER DIEM

TEAM MEALS ARE MANDATORY

MEAL ROOM: Plaza Int'l Ballroom G

Most meals will be provided by the Team or Citrus Bowl. Please look at the daily schedule to see when meals and snacks are listed.

Your Incidental/Per Diem money in the amount of **\$270** will be deposited onto your per diem card on Sunday, December 26th prior to departure. This can be used for entertainment or personal use while in Orlando. Make sure you budget your money responsibly.



PLAYER TICKET INFORMATION

Iowa will provide each player **(6)** complimentary tickets for the bowl game.

Players must submit their list of names via Front Rush by:

12:00 PM (EST) on Dec. 27TH

Will Call Gates are located at the center entry roll-up gate in the north end zone, on Church Street between Gate A and Gate F

Opens 2 Hours prior to kick-off and is manned through halftime

Everyone will need a photo ID to enter the game.

POST GAME FAMILY MEETING AREA

The Post Game Family Meeting Area will be set-up near the Team Locker rooms and Bus Compounds.



PLAYER BOWL GIFTS

CITRUS BOWL GIFTS:

- \$400 Amazon Gift Card
- Commemorative Bowl Fossil Watch
- Personalized OGIO bowl backpack (Name/Number)
- Commemorative Bowl Football

***You will be given these gifts at the Welcome Party on the 26th of December**

IOWA BOWL GIFTS:

- \$400 Gift Card

***You will be given this card either prior to Departure or on the 26th of December**

***Recommend registering your card RIGHT AWAY.**



PRE-TRAVEL CHECKLIST

COVID-19 Policy for Team Travel

COVID-19 testing will be required for all individuals traveling on the team plane. Individuals that are fully vaccinated will be exempt from testing. Communication will be sent to all staff members to verify their family member's vaccination status. Those indicated as Not Fully Vaccinated will be provided a home test to be completed on December 23. If the home test indicates positive, a PCR will be conducted. Additional information regarding testing will be dispersed to those needing to schedule a test.

LUGGAGE

1. Bring early luggage to Hansen Football Performance Center loading dock December 20-21 (See Itinerary)
2. Truck Departs on the 21st of December

BUS DEPARTURE INFORMATION

1. You will receive a text with your bus number by **DEC. 22**
2. If you have children, you will receive a separate text with their Info.

Buses depart from Finkbine South Parking Lot

Park cars in the Former University Club Parking Lot or See Map above

3. Bag Lunches will be at buses
4. Bus Departure Times for Charter
 - a. 8:30 AM - BUS 8
 - b. 8:45 AM - BUS 7
 - c. 9:00 AM - BUS 6
 - d. 9:15 AM - BUS 5
 - e. 9:30 AM - BUS 4
 - f. 9:45 AM - BUS 3
 - g. 10:15 AM - BUS 2
 - h. 10:30 AM - BUS 1

22

***You are required to bring a photo ID or passport**

FLIGHT INFORMATION

1. You will receive a text with your plane seat by **DEC. 22**
2. If you have children, you will receive a separate text with their Info.
3. Charter -
 - a. Team Departs 11:30 AM (Cedar Rapids)

*Bus Assignments and Plane Seats will be Posted inside of Loading Dock, please take a look when dropping off luggage. Thank you.



FAMILY ITINERARY

DROP OFF TIMES FOR EARLY ARRIVAL LUGGAGE TRUCK

Monday, December 20th - 3:00-5:00 PM

Tuesday, December 21st - 12:00-5:00 PM / Truck Departs at 6:00 PM

SUNDAY, DECEMBER 26, 2021

8:30 am Bus 8 Departs Finkbine South Parking Lot

8:45 am Bus 7 Departs Finkbine South Parking Lot

9:00 am Bus 6 Departs Finkbine South Parking Lot

9:15 am Bus 5 Departs Finkbine South Parking Lot

9:30 am Bus 4 Departs Finkbine South Parking Lot

9:15 am *Airplane Luggage Truck Departs - HFPC Loading Dock*

10:00 am Bus 3 Departs Finkbine South Parking Lot

10:15 am Bus 2 Departs Finkbine South Parking Lot

10:30 am Bus 1 Departs Finkbine South Parking Lot

11:30 am **Team Charter Departs Cedar Rapids, IA**

3:15 pm (EST) **Team Charter Arrives - Orlando, FL**

SET WATCHES FORWARD 1 HOUR

4:00 pm Team Buses Arrive - Hyatt Regency

4:30 pm Pick-Up Personal Luggage

*Text will be sent when they are all set.



FAMILY ITINERARY

MONDAY, DECEMBER 27, 2021

- 7:30-9:00 am Breakfast for Travel Party Families – Barrel Spring
- Need to have Credential
- 2:00-5:00 pm Family Suite Open to bring Kids – Barrel Spring
- Snacks, Juice, etc. provided
- 6:30pm-12:00 am VIP Hospitality Suite Open – Orchid Room
- Need Credential
 - Official Travel Party Only
 - No Children under the age of 18

No Events

TUESDAY, DECEMBER 28, 2021

- 7:30-9:00 am Breakfast for Travel Party Families – Barrel Spring
- Need to have Credential
- 2:00-5:00 pm Family Suite Open to bring Kids – Barrel Spring
- Snacks, Juice, etc. provided
- 6:30pm-12:00 am VIP Hospitality Suite Open – Orchid Room
- Need Credential
 - Official Travel Party Only
 - No Children under the age of 18



FAMILY ITINERARY

WEDNESDAY, DECEMBER 29, 2021

- 7:30-9:00 am Breakfast for Travel Party Families – Barrel Spring
- Need to have Credential
- 2:00-5:00 pm Family Suite Open to bring Kids – Barrel Spring
- Snacks, Juice, etc. provided
- 6:30pm-12:00 am VIP Hospitality Suite Open – Orchid Room
- Need Credential / Official Travel Party Only
 - No Children under the age of 18

No Events

THURSDAY, DECEMBER 30, 2021

- 7:30-9:00 am Breakfast for Travel Party Families – Barrel Spring
- Need to have Credential
- 2:00-5:00 pm Family Suite Open to bring Kids – Barrel Spring
- Snacks, Juice, etc. provided
- 2:00 pm Buses Depart Hotel for Universal Orlando Resort
- 2:30-8:30 pm Universal Orlando Resort (Team Event)
- Ticket Needed (Purchased in Advance)
 - Return Buses: 5:30 pm / 7:00 pm / 8:30 pm
- 6:00-10:00 pm Kids' Night Out – Hyatt Regency (Barrel Spring Ballroom)
- Must Register your child in Advance. Parents need to provide the name, age and any special dietary restrictions or special instructions for all children.
- 6:30pm-12:00 am VIP Hospitality Suite Open – Orchid Room
- Need Credential / Official Travel Party Only
 - No Children under the age of 18
- 6:30 pm Buses Depart for VIP Welcome Party
- 7:00 pm VIP Welcome Party – Dr. Phillips Center for the Performing Arts
- *Invitation Only* / Required: Head Coach, Athletic Director
 - Dress: Cocktail



FAMILY ITINERARY

FRIDAY, DECEMBER 31, 2021

- 7:30-9:00 am Breakfast for Travel Party Families - Barrel Spring
- Need to have Credential
- 2:00-5:00 pm Family Suite Open to bring Kids - Barrel Spring
- Snacks, Juice, etc. provided
- 2:45 pm Buses Depart Hyatt for Team Picture
- 3:20 pm Family Photo Op with Players/Staff
- 4:00-4:45 pm Buses Depart Stadium for Hotel - ON FLOW
- 6:30pm-1:00 am VIP Hospitality Suite Open - Orchid Room
- Need Credential / Official Travel Party Only
 - No Children under the age of 18

SATURDAY, JANUARY 1, 2022

26

- 9:00am-1:00 pm Vrbo Citrus Bowl FANFEST - Tinker Field (West Side of Stadium)
- Free Admission
- 10:45 am Buses Depart Hotel for Stadium
- 11:00 am Buses Arrive - Camping World Stadium
- 1:00 pm BEAT KENTUCKY - BRING TROPHY HOME**
- Post Game Buses Depart Stadium for Hyatt Regency
- *Please report to the buses NO later than 45 minutes following game. Buses will leave with or without you.*
- 7:30-9:00 pm Luggage Ready for Return Trip can be Brought down
- Place in Plaza Int'l Ballrooms D-F
 - Place in corresponding line (See Signs)



FAMILY ITINERARY

SUNDAY, JANUARY 2, 2022

6:30 am	<i>Team Semi & Airplane Box Truck Ready for Loading - Service Road</i>
7:15-9:15 am	Travel Party Breakfast - Plaza Int'l Ballroom G
8:00 am	Bus 7 Departs Hyatt for Airport
8:15 am	Bus 6 Departs Hyatt for Airport
8:30 am	<i>AIRPLANE LUGGAGE TRUCK Departs Hyatt for Charter</i>
8:30 am	Bus 5 Departs Hyatt for Airport
8:45 am	Bus 4 Departs Hyatt for Airport
9:00 am	Bus 3 Departs Hyatt for Airport
9:15 am	Bus 2 Departs Hyatt for Airport
9:30 am	Bus 1 Departs Hyatt for Airport
10:30 am	Charter Departs Orlando, FL

SET WATCHES BACK 1 HOUR

27

12:30 pm	Charter Lands Cedar Rapids, IA
1:15 pm	Buses Arrive - Finkbine
TBA	Luggage Dropped Off at Hansen Football Performance Center <ul style="list-style-type: none">• Ben Hansen will send out a text when luggage is ready.



EVENT DESCRIPTIONS

TEAM WELCOME MEAL

Date: Sunday, December 26

Location: Hyatt Regency - Orlando Ballroom LMN

Attendance: Mandatory for Team / Welcome to Coaches & Student Staff

- No Spouses or Children

Time: Following Team Meeting

Attire: Casual

To kick off bowl week activities, the bowl staff and volunteers will welcome the players to Central Florida with an exclusive party! With a red carpet entrance, the players will enjoy a ballroom transformed into their very own private lounge.

ORLANDO MAGIC GAME

Date: Tuesday, December 28

Location: Amway Center

Attendance: Optional for Players

Time: 7:00 pm / Orlando Magic vs. Milwaukee Bucks

Attire: Casual

Allotment: 125 (Players Only)

28

PLAYER OUTING - TOPGOLF

Date: Wednesday, December 29

Location: Topgolf Orlando

Attendance: Players & Student Staff

Time: 8:00-10:00 pm

Attire: Casual

Topgolf will host bowl teams for a fun evening of golf and food. Teams will have an opportunity to compete in several different driving range games that incorporate technology and entertainment.



EVENT DESCRIPTIONS

FCA BREAKFAST – OPTIONAL

Date: Thursday, December 30
Location: First Baptist Church Faith Hall
Attendance: Official Team Party (Optional)
Time: 7:00 am
Attire: TBD
Keynote Speaker: Lou Holtz

Complimentary for Team Party (Players). Additional tickets are \$10 for students and \$25 for adults

*If interested in individual tickets contact: Mark Rickman - mrickman@fca.org

Orange County FCA is hosting the 51st Annual Citrus Bowl Breakfast on December 30th! You don't want to miss a message from legendary Coach Lou Holtz. Other highlights will include testimonies from each team, a delicious breakfast provided by First Baptist Orlando, and a special presentation of awards to local high school football players.

DAY FOR KIDS

Date: Thursday, December 30
Location: Fun Spot America Theme Park
Attendance: All Players, Coaches and Sports Information Director
Time: 9:00-11:00 am
Attire: Players - Jersey or Warmups with number displayed

Day for Kids pairs children from the Bowl's MVP families, Boys & Girls Clubs of Central Florida and the West Lakes neighborhoods near Camping World Stadium for a few hours of rollercoasters, go-karts and more at Fun Spot America.



EVENT DESCRIPTIONS

UNIVERSAL ORLANDO RESORT

Date: December 30 (Players on 30th) / Staff who Purchased: Any Day

Location: Universal Orlando Resort

Attendance: Players and Student Staff / Staff or Families that purchased Ticket

Time: 2:00-8:30 pm

Attire: Team Jersey or Warmups

Cost: **For those electing to purchase, you can choose any day we are down there**
/ If going separate from team, you will need to get your own way to Resort.

The Official Team Party will have the opportunity to visit Universal Orlando Resort.

KIDS' NIGHT OUT

Date: Thursday, December 30

Location: Hyatt Regency, Barrel Spring Ballroom

Attendance: Private event for Children of parents attending the VIP Welcome Party

Time: 6:00-10:00 pm

30

****Light Snack will be provided***

Professional Childcare providers will implement a customized, safe and fun children's program. They will come prepared with arts and crafts, table and video games, movies and more! There will also be a goody bag for each child.

SEAWORLD

Date: Any Day while we are down there. Team will be Optional on the 27th.

Location: SeaWorld Orlando

Attendance: Travel Party

Enjoy SeaWorld Orlando, which is located not to far from our Hotel. Tickets will be provided at key pick-up on the 26th of December.



EVENT DESCRIPTIONS

VIP WELCOME PARTY

Date: Thursday, December 30
Location: Dr. Phillips Center for the Performing Arts
Attendance: **Invite Only** / Required: Head Coach, Athletic Director
Allotment: Maximum 60
Time: 7:00 pm
Dress: Cocktail

A private event for school presidents, coaches, athletics directors, Official VIP Travel Party and their spouses with the Bowl and community leadership,

**Both Head Coaches to speak briefly*

PREGAME HOSPITALITY PAVILION

Date: Saturday, January 1
Location: Tinker Field (West Side of Stadium)
Attendance: Ticket Needed (*Would need to Purchase*)
Cost: \$85 per person / Contact Carlyn Tribble (ctribble@fcsports.com)
Time: 10:00 am-1:00 pm

**Transportation would be on your own. / Unless arriving later with Team*

The Vrbo Citrus Bowl's premier, pregame tailgate destination. Guests enjoy unlimited all-inclusive premium food and beverages inside a climate controlled tent featuring lounge seating, HDTVs, music and private performances from the Big Ten and SEC marching bands, mascots and cheerleaders.

FANFEST

Date: Saturday, January 1
Location: Tinker Field (West Side of Stadium)
Attendance: Free to All to Attend
Time: 9:00 am-1:00 pm
**Transportation would be on your own. / Unless arriving later with Team*

The official bowl pregame FanFest will feature interactive games, inflatables, face painters and more! A wide selection of food and beverages will be available for purchase from local vendors.



VIP TRAVEL PARTY HOSPITALITY SUITE

Hyatt, Orchid Room

This will be for Official Travel Party. Credential required

***NO CHILDREN UNDER THE AGE OF 18**

Dates: December 26th- December 30th

Hours: 6:30-12:00 am

Dates: December 31st-January 1st

Hours: 6:30pm-1:00 am

*The Staff Hospitality Room is for the adult members of our **OFFICIAL TRAVEL PARTY ONLY**. This room is not for anyone outside of our official travel party. Travel party members are recommended to wear their badge when entering the Staff Hospitality Room.*

32

VIP TRAVEL PARTY FAMILY SUITE

Hyatt, Barrel Spring

This will be for members of your official party, coaches, staff, their spouses and children. Hot Breakfast each morning, snacks in the afternoon for children.

Dates: December 27th – January 1st

Hours:

7:30-9:00 am – Hot Breakfast

2:00-5:00 pm – Suite Access

Stocked with snacks, juice boxes, etc.



HOTEL AMENITIES

- Complimentary Wi-Fi
- 24-Hour StayFit Fitness Center
- Two outdoor pools, one with a waterslide and splashpad
- Pet-Friendly
- The Spa, with full-service salon
- Laundry

HOTEL FOOD & DRINK OPTIONS

1. Market Orlando, open 24/7
2. 24-hour in-room dining options
3. Coconuts Poolside Bar & Grill, served at Grotto Pool
4. B-Line Diner
5. Fiorenzo, private dining available
6. Rocks bar with sweeping views, private dining available
7. Lobby Bar





BEST RESTAURANTS IN ORLANDO

The Monroe // 407-734-2102 // [Menu](#)

Cuisine: American

Address: 448 N Terry Ave. Orlando, FL 32801

Price: \$\$

Hours: Lunch: 11AM-3PM; Dinner: 5PM-10PM; Coffee Bar: 9AM-3PM

Distance from Team Hotel: 14 miles

Located on the ground floor of The Julian Apartments at Creative Village in Downtown Orlando, The Monroe is a diverse social gathering place with a main dining room, bar, lounge/study, semi-private dining area, and daytime coffee shop.

Eddie V's Prime Seafood // 407-355-3011 // [Menu](#)

Cuisine: Seafood/Steakhouse

Address: 7488 West Sand Lake Rd. Orlando, FL 32819

Price: \$\$\$

Hours: Mon-Sat: 4-10PM, Sun: 4-9PM

Distance from Team Hotel: 3 miles

Choose from a varied selection of the finest seafood available // Indulge in our critically acclaimed prime center cut steaks, aged 28 days and broiled to perfection // Complement your meal with a selection from our wine menu - an award-winning list of more than 200 wines curated by our Master Sommelier

Dragonfly Robata Grill & Sushi // 407-370-3359 // [Menu](#)

Cuisine: Asian Fusion/Sushi

Address: 7972 Via Dellagio Way, Orlando, FL 32819

Price: \$\$\$

Hours: 5PM-10PM; Happy Hour 5PM-7PM

Distance from Team Hotel: 3.2 miles

Japanese robata-yaki. Made new. Friends around an open hearth. Fresh selections from farm and sea. Grilled slowly. Authentic. Contemporary. Always enjoyed.

Jimmy Buffett's Margaritaville // 407-224-2155 // [Menu](#)

Cuisine: American

Address: 6000 Universal Studios Plaza, Suite 704, Orlando, FL 32819

Price: \$\$

Hours: 11AM-10PM

Distance from Team Hotel: 4 miles

Joint with burgers & other American fare, a volcano bar & late-night live music & dancing.



BEST RESTAURANTS IN ORLANDO

Vivo Italian Kitchen // 407-224-3663 // [Menu](#)

Cuisine: Italian

Address: 6000 Universal Blvd, Orlando, FL 32819 (Universal CityWalk)

Price: \$\$

Hours: Sun-Thurs: 5PM-10PM, Fri-Sat: 5PM-11PM

Distance from Team Hotel: 4 miles

Celebrate the beauty of true Italian cuisine where heirloom family recipes are served up in a sleek, modern setting. The pasta is handmade before your eyes. Watch as it's prepared from an open kitchen, along with fresh sauces, pizza, mozzarella and bread. The finest ingredients ensure every meal is authentic, robust, and full of flavor.

Bubba Gump Shrimp Co. // 407-903-0044 // [Menu](#)

Cuisine: Seafood

Address: 6000 Universal Blvd, Suite 735, Orlando, FL 32819 (Universal CityWalk)

Price: \$\$

Hours: Sun-Thurs: 5PM-10PM, Fri-Sat: 5PM-11PM

Distance from Team Hotel: 4 miles

Family-friendly chain for seafood & American fare served in a fishing-boat-themed setting.

Kres Chophouse // 407-447-7950 // [Menu](#)

Cuisine: Steakhouse

Address: 17 W Church St, Orlando, FL 32801

Price: \$\$\$

Hours: Mon-Thurs: 11:30AM-11PM, Fri: 11:30AM-12AM, Sat: 5PM-12AM, Sun: 5PM-10PM

Distance from Team Hotel: 13 miles

Creative & modern, while still honoring the classics, Kres Chophouse is an independent steakhouse that crosses the traditional boundaries to deliver extraordinary value and a "historic" dining experience. Our Prime Beef is aged in-house and hand-cut to order. Ultra-fresh Florida coastal fish and regional seafood is delivered daily. Our mission is to obtain the finest quality at the best value for our guests. The search is never-ending.



NECESSITIES AND SERVICES

Walgreens

Address: 9858 International Dr, Orlando, FL

Distance from Team Hotel: 0.3 miles

Hours: 7AM-1AM

CVS Pharmacy

Address: 9188 International Dr, Orlando, FL

Distance from Team Hotel: 1.0 miles

Hours: 7AM-12AM

Publix Super Market at Lake Cay Commons

Address: 9930 Universal Blvd, Orlando, FL

Distance from Team Hotel: 1.5 miles

Hours: 7AM-10PM

Dunkin'

Address: 9898 International Dr, Orlando, FL

Distance from Team Hotel: 0.6 miles

Hours: Sun-Thurs 6AM-5PM; Fri & Sat 6AM-7PM

36

Starbucks

Address: 10725 International Dr, Orlando, FL

Distance from Team Hotel: 1.5 miles

Hours: 5:30AM-9PM

Wells Fargo

Address: 7740 W Sand Lake Rd, Orlando, FL

Distance from Team Hotel: 3.4 miles

Hours: Mon-Fri 9AM-5PM; Sat 9AM-12PM



HOTEL AREA MAP

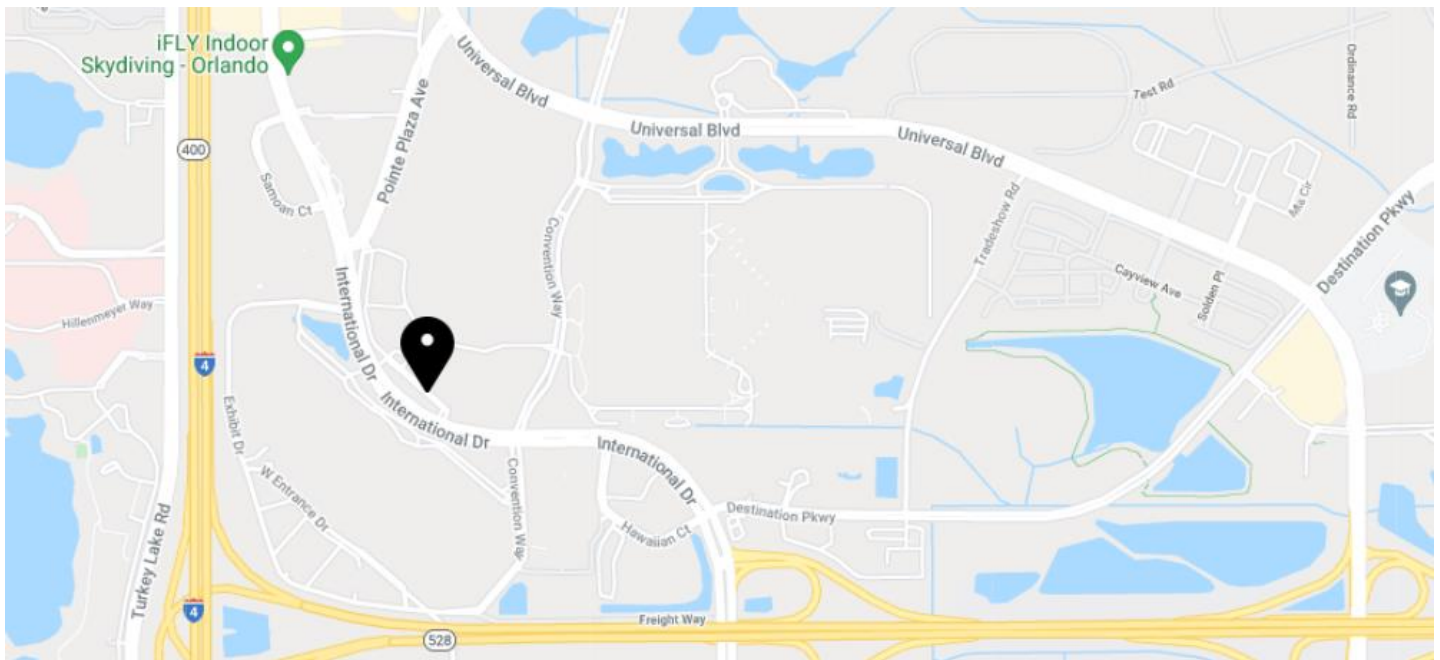
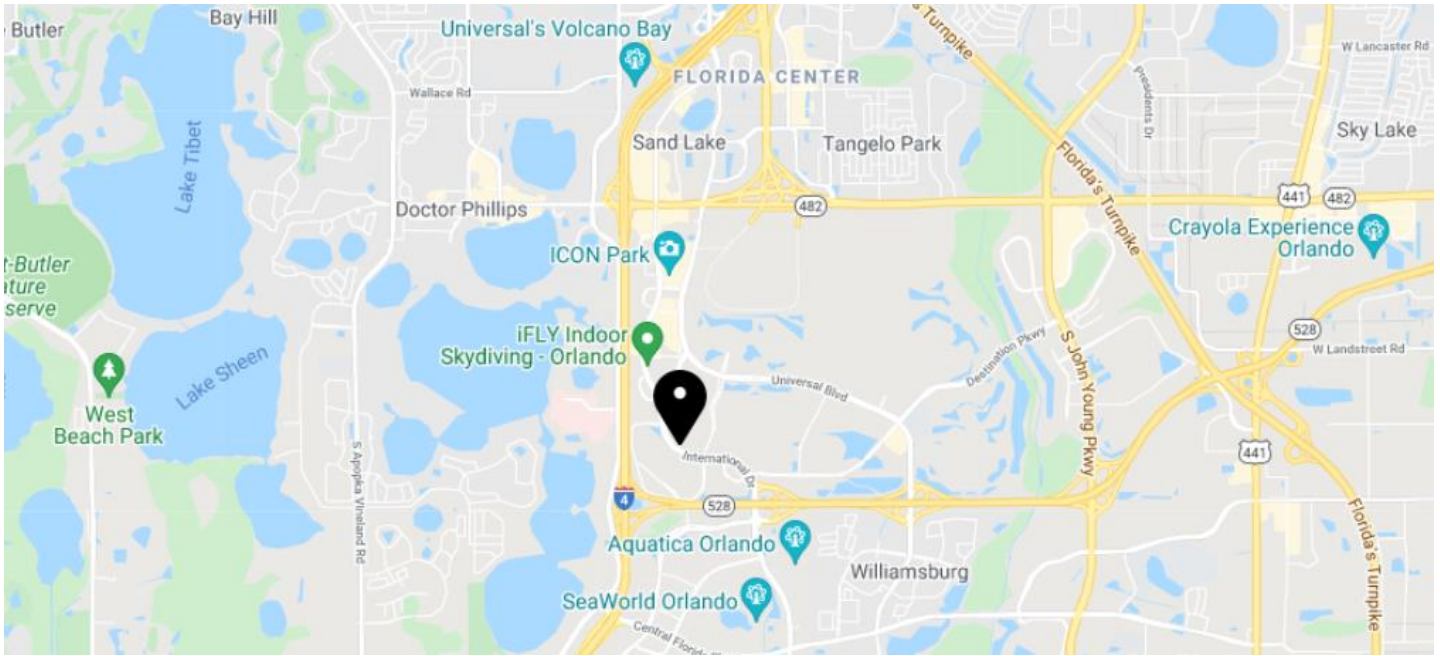



AREA ATTRACTIONS

Iconic Orlando Venues

Lake Eola Park // 512 E Washington St, Orlando, FL // [Website](#)

Central Florida Zoo & Botanical Gardens // 3755 W. Seminole Blvd, Sanford, FL // [Website](#)

Gatorland // 14501 S. Orange Blossom Trail, Orlando, FL // [Website](#)

Topgolf Orlando // 9295 Universal Blvd, Orlando, FL // [Website](#)

Orlando Museum of Art // 2416 N Mills Ave, Orlando, FL // [Website](#)

Museum of Illusions Orlando // 8375 International Dr, Orlando, FL // [Website](#)

Great for Kids

SeaWorld Orlando // 7007 Sea World Dr, Orlando, FL // [Website](#)

Universal Orlando Resort // 7000 Universal Blvd, Orlando, FL // [Website](#)

Walt Disney World Resort // 1375 E Buena Vista Dr, Orlando, FL // [Website](#)

ICON Park // 8375 International Dr, Orlando, FL // [Website](#)

Andretti Indoor Karting & Games // 9299 Universal Blvd, Orlando, FL // [Website](#)

ESPN Wide World of Sports Complex // 700 S Victory Way, Orlando, FL // [Website](#)

Orlando Science Center // 777 E Princeton St, Orlando, FL // [Website](#)

Sea Life Orlando Aquarium // 8449 International Dr, Orlando, FL // [Website](#)

Crayola Experience // 8001 S Orange Blossom Trl, Orlando, FL // [Website](#)

Ripley's Believe It or Not // 8201 International Dr, Orlando, FL // [Website](#)

Shopping

Orlando International Premium Outlets // 5269 International Dr, Orlando, FL // [Website](#)

Disney Springs at Walt Disney World Resort // 1486 E Buena Vista Dr, Orlando, FL // [Website](#)

Universal CityWalk at Universal Orlando Resort // 6000 Universal Blvd, Orlando, FL // [Website](#)

Pointe Orlando // 9101 International Dr, Orlando, FL // [Website](#)

The Mall at Millenia // 4200 Conroy Rd, Orlando, FL // [Website](#)

The Florida Mall // 8001 S Orange Blossom Trl, Orlando, FL // [Website](#)

Lake Buena Vista Factory Stores // 15657 S Apopka Vineland Rd, Orlando, FL // [Website](#)



Religious Services

Roman Catholic - St. Nicholas Catholic Church // 5135 Sand Lake Rd, Orlando, FL // 407-351-0133

Lutheran - Christ the King Lutheran Church // 4962 S Apopka Vineland Rd, Orlando, FL 32819 // 407-876-2771

Presbyterian - Presbyterian Church of The Lakes // 4700 Lincoln Ave, Orlando, FL // 407-291-2886



HELPFUL APPS



Open Table

Cost: Free

What it does: Discover, reserve, and manage restaurant reservations free and instantly—anytime, anywhere. Get last-minute access to more restaurants around the world with the leader in restaurant reservations. Earn points towards rewards every time you dine with the OpenTable app. Download free today.

Works with: Apple, Android

[Download](#)



Transit

Cost: Free

What it does: Transit is your real-time urban travel companion. Navigate your city's public transit system with accurate realtime predictions, simple trip planning, step-by-step navigation, service disruption notifications, and departure and stop reminders, all presented in a clear, bold interface. Public transport not cooperating? Easily request an Uber, reserve a car2go, or grab the closest bike share.

Works with: Apple, Android

[Download](#)



Uber

Cost: Free

What it does: Uber is a ridesharing app for fast, reliable rides in minutes—day or night. There's no need to park or wait for a taxi or bus. With Uber, you just tap to request a ride, and it's easy to pay with credit or cash in select cities.

Works with: Apple, Android

[Download](#)



Lyft

Cost: Free

What it does: Use Lyft to get an affordable ride in minutes. Ride-sharing with Lyft lets you request a car with the tap of a button and get picked up by a nearby friendly driver who'll take you to your destination right away. Get rides from our highly-rated drivers instead of hailing a cab or waiting for the bus and enjoy a welcoming, affordable and memorable ride today!

Works with: Apple, Android

[Download](#)



CAMPING WORLD STADIUM INFORMATION

Orlando Venues is committed to providing a superb, memorable and exciting experience in a safe environment for all of our patrons. Anyone interfering with the event or disturbing other guests may be escorted from the stadium and could be subject to prosecution.

BAGS, BACKPACKS, AND PURSES

Large bags, coolers, and backpacks are not permitted. There are no storage lockers on the premises so please leave all non-essential items. An exception will be made for medically necessary items after proper inspection at a gate.

COVID-19 UPDATES

Keeping the health and safety of our guests and employees at the forefront of everything we do, we will be following guidelines set forth by the Centers for Disease Control (CDC) as well as local officials, the NBA and experts from AdventHealth. Please find the link to our Health and Safety Policies page below for complete details.

41

EMERGENCY EVACUATION

In the unlikely event of an emergency, the Camping World Stadium staff will utilize the public address system to inform our guests of the situation and any instructions as applicable. All exits and emergency exits are posted with appropriate signage.

FIRST AID STATIONS

The primary first aid office is located on the field level by Gate C across from section 113. There are also roving medical staff throughout the stadium during events.



GUEST CONDUCT

Camping World Stadium is committed to creating a safe, comfortable and enjoyable experience for all fans, both in the stadium and parking lots. The following is a list of behaviors that will not be tolerated:

- Abusive, foul or disruptive language and obscene gestures
- Intoxication or signs of impairment related to alcohol consumption or drug use
- Fighting, taunting or threatening remarks or gestures
- Distributing handbills, pamphlets, etc., unless authorized by stadium management and the licensee renting the facility
- Sitting in a location other than the guest's ticketed seat
- Displays of affection not appropriate in a public setting
- Obscene or indecent clothing
- Disruption to the progress of the event by a guest's actions, including throwing or kicking objects
- Behavior which otherwise interferes with other guests' enjoyment
- Smoking* except in designated locations (*This policy applies to electronic and smokeless cigarettes) and spitting tobacco
- Entering the stadium with unlawful weapons of any kind (except those required by Florida Law)
- Standing on chair seats or stepping over chair backs
- Standing or sitting in walkways, aisles or ramps
- Placing cups on the wall
- Failing to follow event staff instructions
- Re-entering the stadium

MOBILITY CART SERVICE

A courtesy cart service is available to mobility impaired fans from designated areas surrounding Camping World Stadium. Courtesy cart service will begin at 11:30 am to Gates and Fanfest on Tinker Field. There is a main mobility hub tent on the east and west of the stadium with wheelchair service to gates. Cart Service will continue until one-hour post-event.

WiFi

Significant upgrades have been made for WiFi coverage in the stadium. Complimentary WiFi is made available to our patrons attending events. Simply connect to CWSGuestWiFi. No password required. Agree to terms and conditions and click 'continue'.



CLEAR BAG POLICY

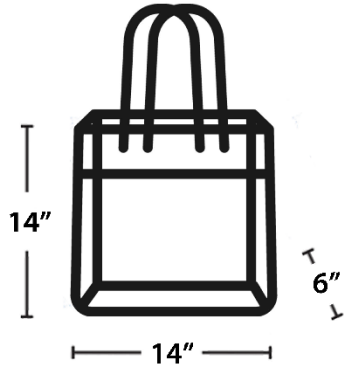

CLEAR TOTE



1 GALLON PLASTIC STORAGE BAG

**MUST BE UNDER
14" x 14" x 6"**

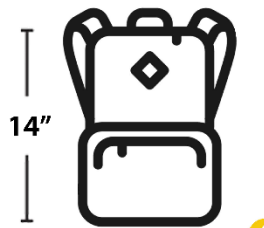

CLEAR  BACKPACK



CLEAR  FANNY PACK

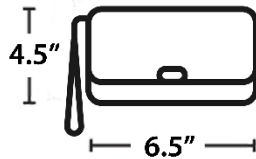

SMALL  CLUTCH



More information at CampingWorldStadium.com/prohibiteditems





CAMPING WORLD STADIUM PARKING

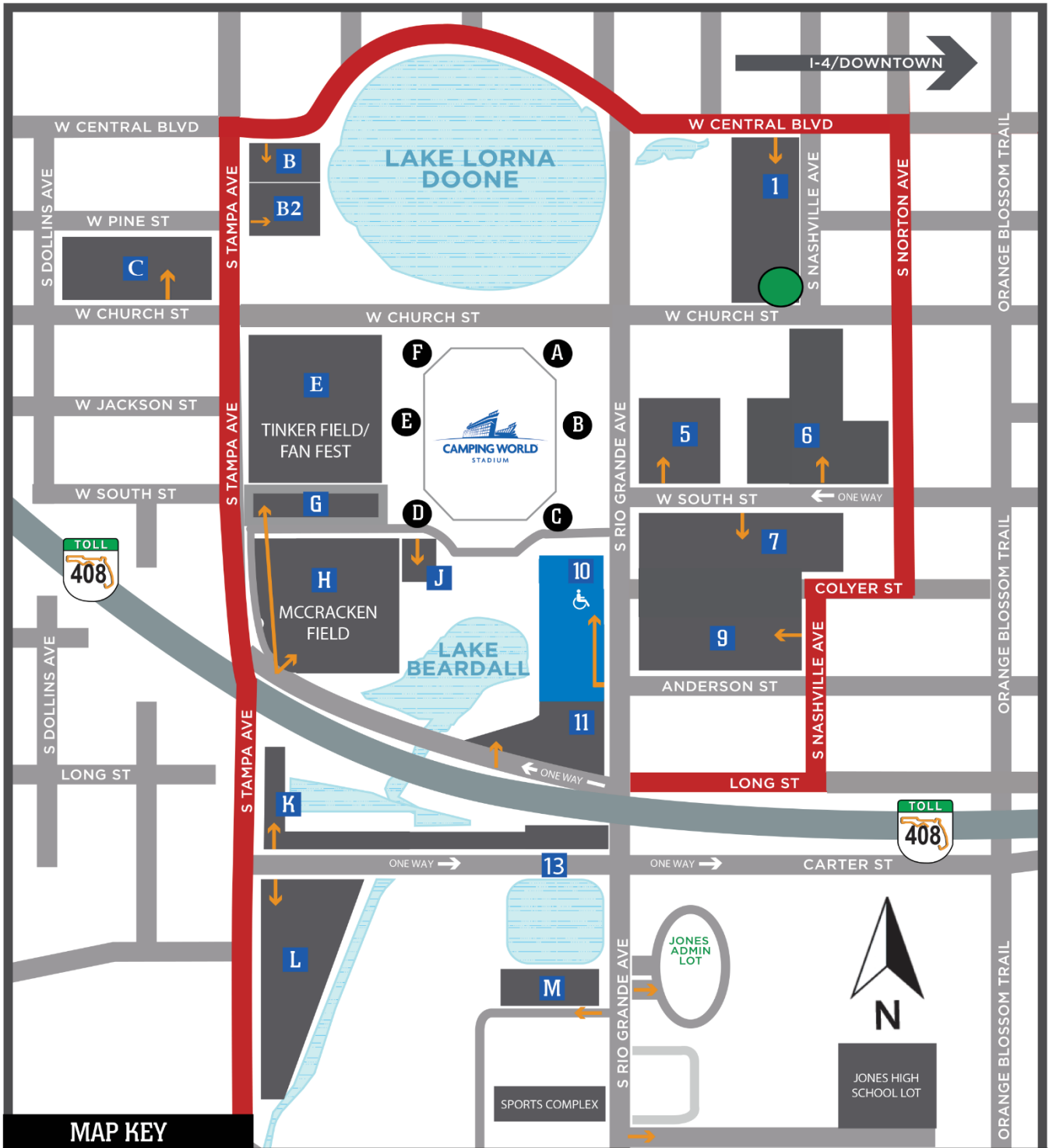

MAP KEY

Guests with parking passes should follow the directions printed on their pass, as some turns will not be permitted on gameday due to road closures near Camping World Stadium.

PARKING

ADA PARKING

PUBLIC SHUTTLE PICK-UP & DROP-OFF

GATE

DENOTES ENTRANCE

PERMIT ACCESS ONLY



STADIUM SEATING CHART



Lower Level & Plaza:

- Bunker Suites
- CenterState Lounge
- Midfield
- Redzone Field
- Redzone Plaza
- Goal Field
- Goal Plaza
- Corner Field
- Corner Plaza
- Endzone Field
- Endzone Plaza

NEW

Club Level:

- Club A
- Club B
- Club C
- Club D
- Loge Boxes

Suite Level:

- East & West Suites
- Skyline Suite
- Veranda Suites

Terrace Level:

- Terrace

