



PC7 (clean – rebuttal version)

Appendix 15: Transportation

15-1 Parking, Loading Spaces and Manoeuvring Areas – Tables and Figures

Table 15-1a: Number of parking, loading and cycle spaces

Activity	Car parking spaces <u>(except for Rotokauri North – see Table 15- 1aa)</u>	Loading spaces	Visitor cycle spaces	Staff cycle spaces
a) Ancillary residential units and apartment buildings	1 per residential unit	-	1 per 4 units	-
b) Building improvement centre (excluding nurseries and garden centres)	1 per 50m ² gross floor area	1 space	-	-
c) Camping grounds	1 per unit, camp site or caravan site	-	-	-
d) Childcare facilities for less than six children	2 plus 1 per FTE staff member	-	-	-
e) Childcare facilities for six or more children	1 per FTE staff member plus 1 drop-off car space per 5 children that the facility is designed to accommodate	-	-	1 per 100 students
f) Community centre	1 per 30m ² gross floor area	1 space	1 per 50m ² gross floor area	-
g) Single dwellings and duplex dwellings	2 per household or dwelling	-	-	-
h) Drive-through services	1 per 30m ² gross floor area (excluding canopy area over pumps) plus 5 queuing spaces per dispensing facility	1 space	1 per 100m ² gross floor area	1 space per 10 FTE staff

Proposed Plan Change 7:
Rotokauri North Private
Plan Change - Notified
Version

Activity	Car parking spaces <u>(except for Rotokauri North – see Table 15-1aa)</u>	Loading spaces	Visitor cycle spaces	Staff cycle spaces
i) Emergency service facilities	1 car space per on-duty staff person, plus sufficient space for all the emergency vehicles that use the site	-	-	-
j) Health care services	3 per consultant and 1 per FTE staff	1 space	1 per 2 consultants	1 space per 10 FTE staff
k) Home-based business	2 per household plus 1 per vehicle used solely for the home-based business	-	-	-
l) Hospitals	1 per 4 FTE staff plus 1 per 4 beds	1 space per 50 beds	1 per 15 beds	1 per 30 beds
m) Industrial activities (including warehouses) (excluding trade and industry training facilities)	1 per 150m ² gross floor area	1 space per development or per 3000m ² gross floor area, whichever is the greater	-	1 space per 15 FTE staff
n) Industrial activities (trade and industry training facilities only)	1 per FTE staff, plus 1 per 3 students the facility is designed to accommodate	1 space	1 per 3 FTE students	1 space per 15 FTE staff
o) Managed care facilities and rest homes	1 per 3 bedrooms plus 1 per every FTE staff member	-	1 per 60 beds	1 space per 15 FTE staff
p) Marae	1 per 25m ² gross floor area	1 space	1 per 50 m ² gross floor area or 1 for every 5 persons the facility is designed to accommodate, whichever is the greater	-
q) Nurseries and garden centres	1 space per 200m ² site area and a minimum of 4 spaces	-	-	1 space per 15 FTE staff
r) Offices	1 per 40m ² gross floor area	1 space	1 per 800m ² gross floor area	1 per 250m ² gross floor area

Activity	Car parking spaces <u>(except for Rotokauri North – see Table 15-1aa)</u>	Loading spaces	Visitor cycle spaces	Staff cycle spaces
s) Outdoor recreational area including playing fields, courts and tracks	1 per 3 participants based on the maximum number of participants that the area is designed to accommodate	-	1 per 20 participants based on the maximum number of participants that the area is designed to accommodate	-
t) Places of assembly (except libraries and museums)	1 per 15 m ² gross floor area or 1 for every 5 persons the facility is designed to accommodate, whichever is the greater	1 space	1 per 50 m ² gross floor area or 1 for every 5 persons the facility is designed to accommodate, whichever is the greater	-
u) Places of assembly (Libraries and museums only)	1 per 30m ² gross floor area	1 space	5 spaces plus 1 per 200m ² gross floor area	1 space per 10 FTE staff
v) Places of worship	1 per 30m ² gross floor area	1 space	1 per 50 m ² gross floor area or 1 for every 5 persons the facility is designed to accommodate, whichever is the greater	-
w) Buildings serving outdoor recreational areas and indoor recreation buildings	1 per 20m ² gross floor area	1 space	1 per 50m ² gross floor area	-
x) Research and Innovation activities	1 per 40m ² gross floor area	1 space	1 per 350m ² gross floor area	1 space per 10 FTE staff
y) Residential centres	1 per FTE staff plus 1 per 3 bedrooms	-	1 per 5 beds	1 space per 15 FTE staff
z) Retail activities (gross floor area less than 5000m ² ; in individual ownership/tenancy or integrated retail development)	1 per 20m ² gross floor area	1 space	1 per 500m ² GLFA	1 per 250m ² GLFA

Activity	Car parking spaces <u>(except for Rotokauri North – see Table 15- 1aa)</u>	Loading spaces	Visitor cycle spaces	Staff cycle spaces
aa) Retail activities (gross floor area greater than 5000m ² and less than 10,000m ² gross floor area; in individual ownership/tenancy or integrated retail development)	1 per 30m ² gross floor area	1 space	1 per 500m ² GLFA	1 per 250m ² GLFA
bb) Retail activities (gross floor area greater than 10,000m ² ; in individual ownership/tenancy or integrated retail development)	1 per 40m ² gross floor area	1 space	1 per 500m ² GLFA	1 per 250m ² GLFA
cc) Retail activities – bulky goods only	1 per 50m ² gross floor area	1 space	-	1 space per 10 FTE staff
dd) Retail activities – outdoor only	1 per 100m ² of uncovered display area	-	-	1 space per 10 FTE staff
ee) Retail activities – indoor display areas for vehicles, boats and agricultural and industrial machinery only	1 per 150m ² gross floor area	1 space	-	1 space per 10 FTE staff
ff) Retail activities – food and beverage, cafes, restaurants and licensed premises only	1 per 10m ² gross floor area	1 space	1 per 125m ² gross floor area	1 per 400m ² gross floor area
gg) Retail activities – supermarkets only	1 per 20m ² gross floor area devoted to retail sales activities and 1 per 40m ² gross floor area for all other activities	1 space	1 per 500m ² GLFA	1 space per 10 FTE staff
hh) Retirement villages	1 per unit plus 1 for every four units	-	1 per 60 beds	1 space per 15 FTE staff

Activity	Car parking spaces <u>(except for Rotokauri North – see Table 15-1aa)</u>	Loading spaces	Visitor cycle spaces	Staff cycle spaces
ii) Schools	1 per FTE staff plus 1 drop-off space per 50 primary and intermediate students and 1 per 100 secondary students 1 bus space per 200 students where school bus services are provided. For schools not served by school bus services, no bus spaces are required	-	Primary schools 1 per 20 students Intermediate schools 1 per 5 students Secondary schools 1 per 4 students	1 per 100 students
jj) Showhome	2 per showhome	-	-	-
kk) Tertiary education and specialised training facilities	1 per FTE staff, plus 1 per 3 students the facility is designed to accommodate	1 space	1 per 10 students the facility is designed to accommodate	1 per 10 FTE staff
ll) Transport depots	1 per 100m ² gross floor area of building or site area used for storage, whichever is the greater	1 space	-	1 space per 20 FTE staff
mm) Visitor accommodation	1 per FTE staff member plus the greater of either 1 per 3 visitors that the facility is designed to accommodate or 1 per unit	1 space	1 per 20 beds except hotels where the rate is 1 per 30 bedrooms	1 space per 15 FTE staff

Proposed Plan Change 7:
Rotokauri North Private
Plan Change - Notified
Version

Note

1. The installation of bicycle spaces in an adjoining transport corridor is at the discretion and approval of Council as the Road Controlling Authority and may be subject to specific design requirements.
2. If fewer than four spaces and stands are required then these can be allocated to either visitor or staff parking (or both).
3. If more than four spaces are required then a minimum of 25% should be allocated to visitor use and 25% for staff use only, the remainder can be allocated to either visitor or staff parking (or both).
4. Volume 1, Rule 25.14.4.2(a)ii caps the minimum staff cycle spaces requirement at 1 per 10 FTE staff.
5. The standards in this table do not apply within the Transport Corridor Zone or Natural Open Space Zone (refer to Table 15-1c).
6. The car parking and loading space standards in this table do not apply within the Central City Zone (refer to Table 15-1b).
7. Cycle space standards in this table apply within the Central City Zone.

Table 15-1aa: Number of parking spaces in Rotokauri North

Activity	Car parking spaces
<u>All activities</u>	<u>There are no minimum car parking space requirements</u>

Table 15-1b: Number of parking and loading spaces required – Central City Zone

Activity	Car parking spaces	Loading/service spaces
a) Residential	-	-
b) All other activities	-	1 space per site This standard does not apply where the site has existing development and insufficient space to allow a compliant loading/service space

Table 15-1c: Number of parking and loading spaces in the Natural Open Space Zone and Transport Corridor Zone

Activity	Car parking spaces	Loading/service spaces
a) All activities	-	-

Table 15-1d: Number of accessible spaces required – disabled users – Non-Residential Use – All Zones

Total number of car park spaces being provided	Minimum number of accessible car park spaces for disabled users
1 – 20	1
21 – 50	2
For every additional 50 car parks above 50 car park spaces	1 additional

Table 15-1e: Number of spaces required for less mobile users – All Zones

Total number of car park spaces being provided	Minimum number of car park spaces for less mobile users
50 - 100	1
For every additional 50 car parks above 50 car park spaces	1 additional

Note

1. For the purposes of spaces required by Volume 1 Rule 25.14.4.2(c)ii and Table 15-1e, the allocation and management of use to less mobile users (e.g. elderly, parents with infants, and/or temporary disabilities) is at the discretion of the site owner or occupier.
2. The standards in this table do not apply to offices in the Central City Zone.

Table 15-1f: Number of motorcycle parking spaces required – All Zones

Total number of car park spaces being provided	Minimum number of motorcycle spaces
20-100 spaces	3
For every additional 40 car parks above 100 car park spaces	1 additional

Table 15-1g: Number of bicycle end-of-journey facilities required – Central City Zone and Business Zones 1 to 7

Number of staff cycle spaces	Minimum number of showers		Minimum number of changing rooms
10 – 50	2		2
51 – 150	4		
Each additional 100 cycle spaces	2 additional		

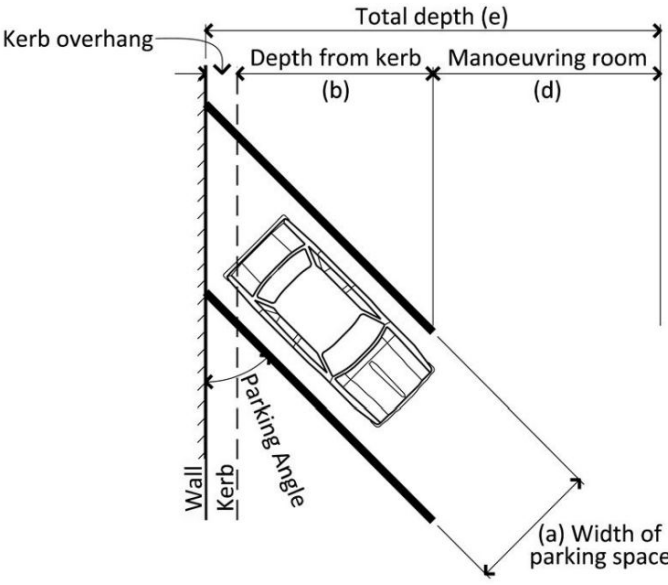
Table 15-1h: Minimum dimensions for on-site parking, loading spaces and manoeuvring areas

Type of parking		Stall width (a)	Stall depth		Manoeuvre width (d)	Total depth (e)	
Parking angle (x)	Type		From wall (b)	From kerb (c)		One row	Two rows
ALL MEASUREMENTS ARE IN METRES							
90	Nose in	2.4	5.1	4.1	7.9	13.0	18.1
		2.5			7.6	12.7	17.8
		2.6			7.2	12.3	17.4
		2.7			6.8	11.9	17.0
75	Nose in	2.4	5.4	4.4	6.4	11.3	17.2
		2.5			5.8	11.2	16.6
		2.6			5.2	10.6	16.0
		2.7			4.6	10.0	15.4
60	Nose in	2.4	5.4	4.5	4.5	9.9	15.3
		2.5			4.2	9.6	15.0
		2.6			3.9	9.3	14.7
		2.7			3.6	9.0	14.4
45	Nose in	2.4	5.0	4.2	3.6	8.6	13.6
		2.5			3.5	8.5	13.5
		2.6			3.4	8.4	13.4
		2.7			3.3	8.3	13.3
30	Nose in	2.4	4.3	3.7	3.0	7.3	11.6
		2.5					
		2.6					
		2.7					
0	Parallel	2.5	Stall length 6.0		3.7	6.2	8.7

- Parallel parking spaces (Parking Angle = 0) shall be 6m long, except where one end of the space is not obstructed, in which case the length of the space may be reduced to 5m.
- Minimum aisle and accessway widths shall be 3m for one way flow, and 5.5m for two way flow. Recommended aisle and accessway widths are 3.5m for one way flow, and 6m for two way flow.

3. Maximum kerb height = 150mm.
4. Parking space dimensions will vary for accessible car park spaces.

Figure 15-1i: Examples of on-site parking configurations

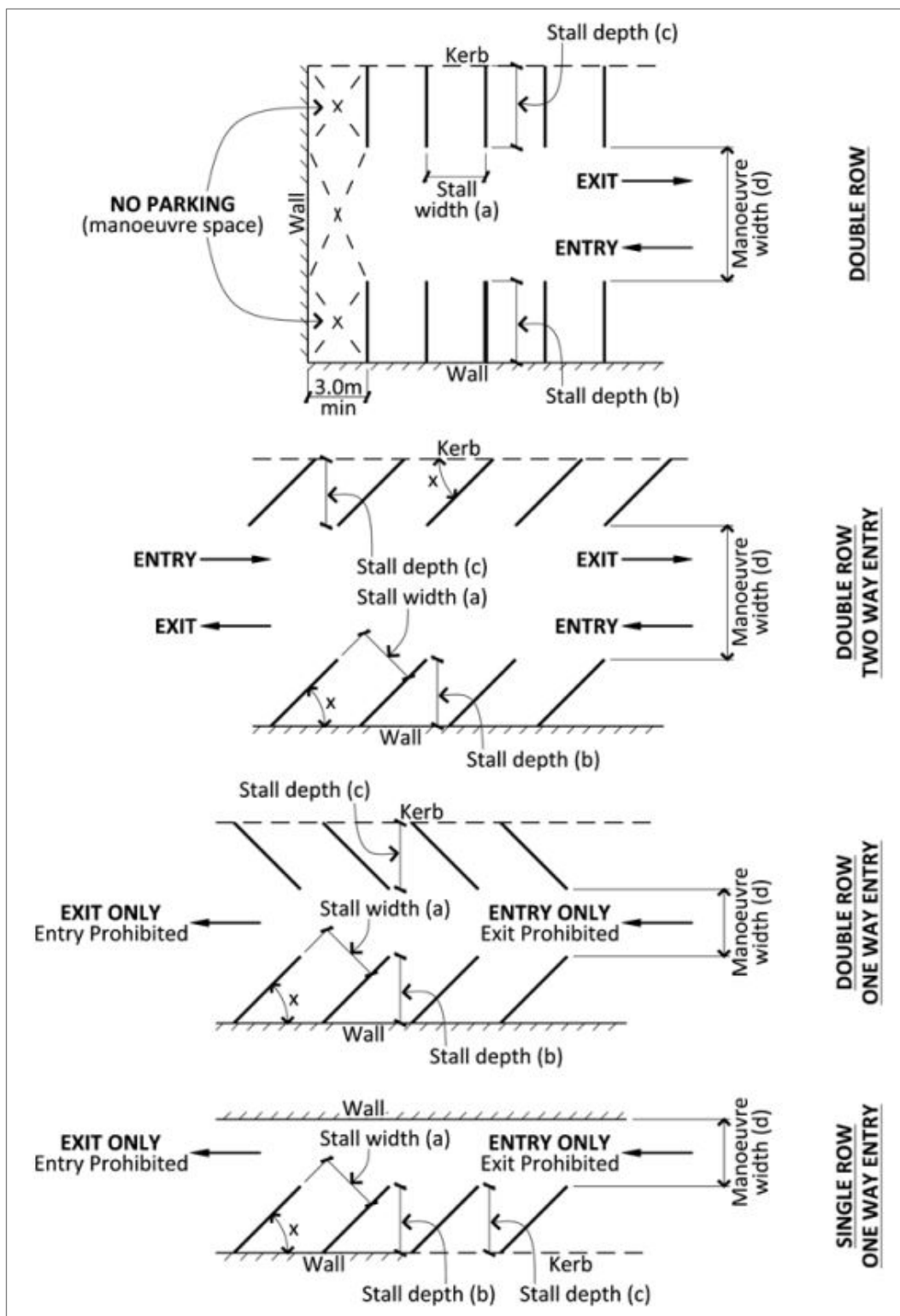

Refer to Table 15-1h for relevant minimum dimensions

Figure 15-1j: 90 Percentile Car Tracking Curve Minimum Radius

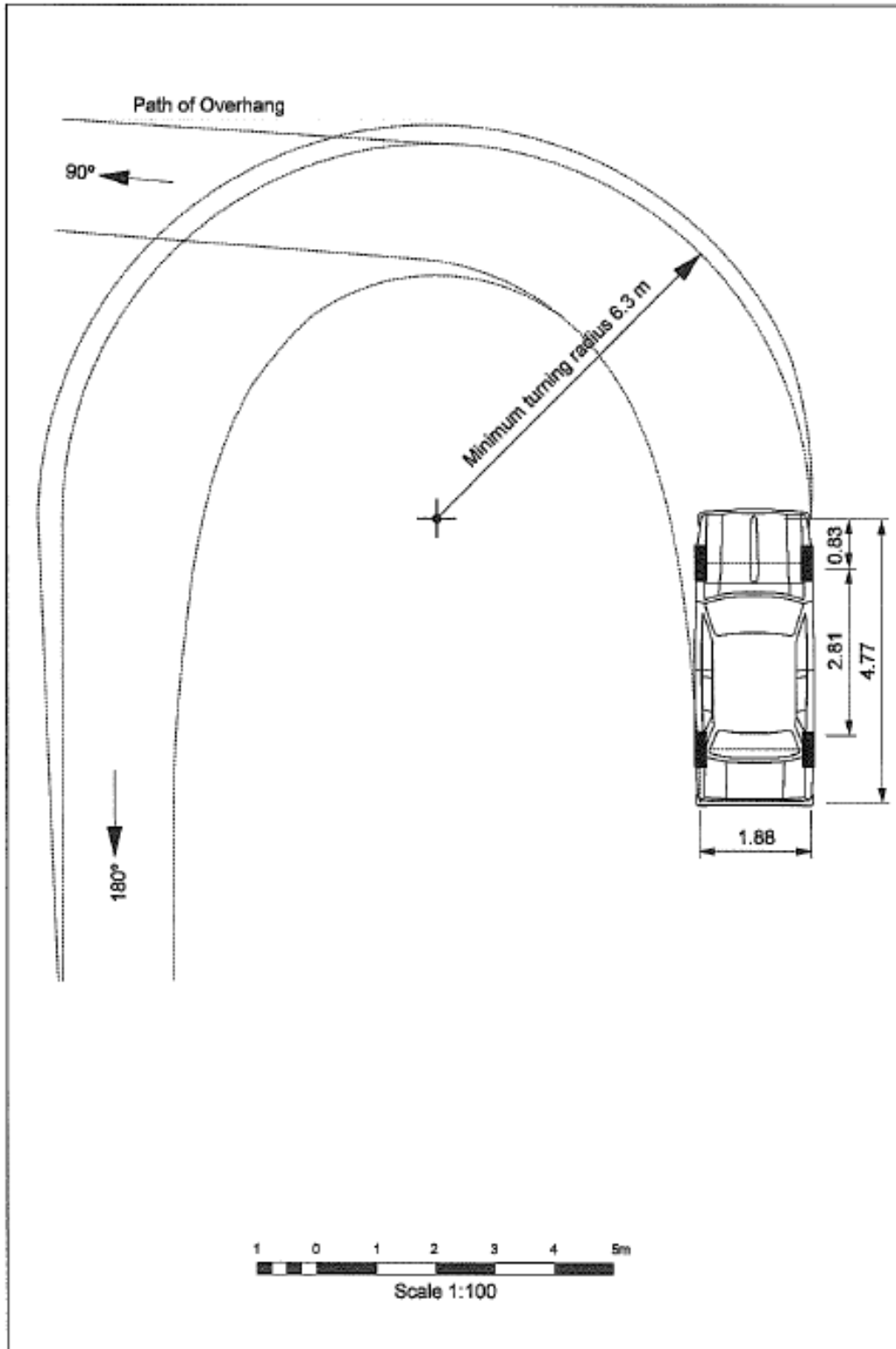

Figure 15-1k: 99 Percentile Car Tracking Curve Minimum Radius

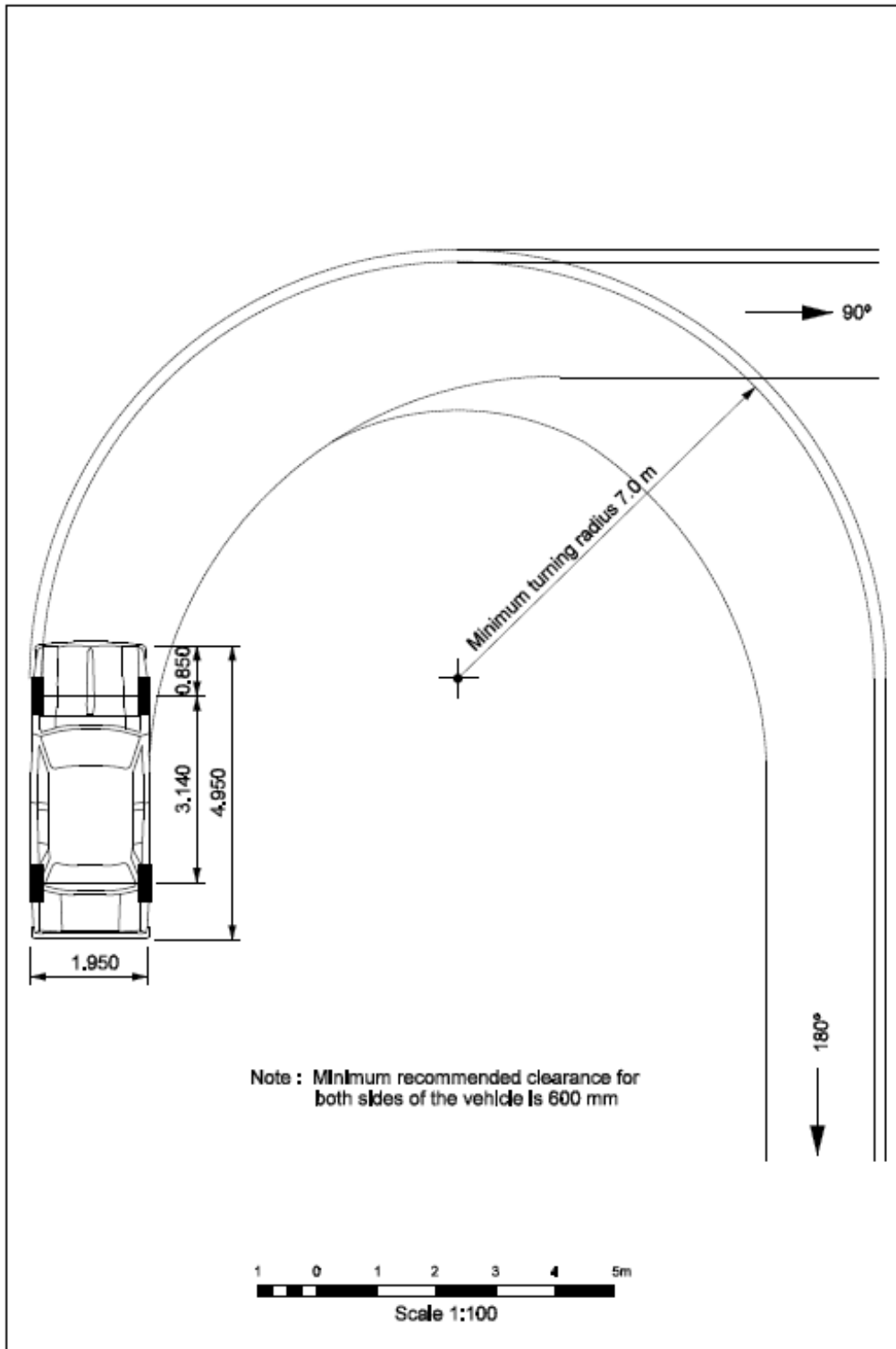
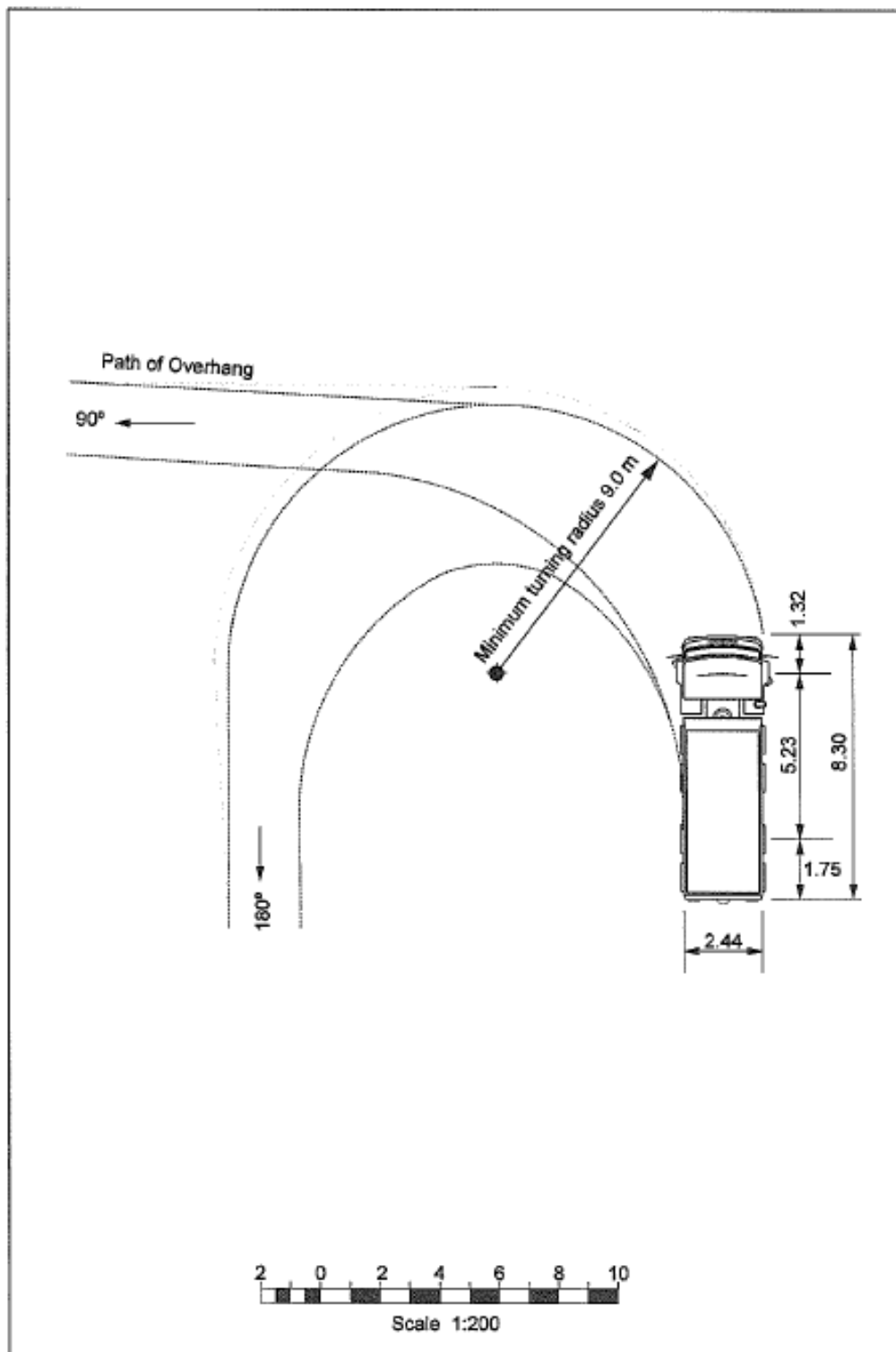

Figure 15-11: 99 Percentile Truck Tracking Curve Minimum Radius



15-2 Integrated Transport Assessment Requirements – Tables

Table 15-2a: Simple ITA checklist

Requirements for Simple ITA ¹	
Item description	Details to be included
a) Background	A description of the proposed activity and the purpose and intended use of the ITA
b) Existing land data	A description of the location, site layout, existing uses, adjacent land uses, any consented or planned changes expected within 10 years likely to affect transport, and zoning
c) Existing transport data	A description of the trip generation and access arrangements for all modes, on-site parking and the surrounding transport network (including hierarchy, traffic volumes, safety and consented or planned changes expected within the next 10 years likely to affect network infrastructure, services and network management
d) Proposal details	A description of the proposal (including site layout, operational hours, vehicle access, on site parking and loading, internal vehicle and pedestrian circulation)
e) Predicted travel data	The trip generation of the proposal for all modes of travel.
f) Appraisal of transportation effects	An assessment of safety and efficiency and effects in the immediate vicinity. Where the proposed activity has the potential to impact on the state highway, a summary of consultation with the New Zealand Transport Agency shall be included
g) Avoiding or mitigating actions	Details of any mitigating measures and revised effects
h) Compliance with policy and other frameworks	Consideration of compliance with District Plan standards
i) Discussion and conclusions	Summary and conclusion assessment of effects
j) Recommendations	Proposed conditions (if any)

Note

1. For further guidance refer to Appendix A of New Zealand Transport Agency Research Report No.422, "Integrated Transport Assessment Guidelines", Abley et al, November 2010.

Table 15-2b: Broad ITA checklist

Requirements for Broad ITA ¹	
Item description	Details to be included ²
a) Background	A description of the proposed activity, the purpose and intended use of the ITA, and an outline of any previous discussions with the relevant road controlling authorities

Requirements for Broad ITA ¹	
Item description	Details to be included ²
b) Existing land data	A description of location, site layout, existing use and consents (if any), adjacent and surrounding land use
c) Existing transport data	A description of the existing access and service arrangements and on-site car parking. A description of the surrounding transport network (including hierarchy, traffic volumes, crash analysis, congestion and intersections). A description of passenger transport modes and accessibility, walking and cycling networks.
d) Committed environmental changes	Consideration of other developments and land use and transport network improvements (including passenger transport, walking and cycling)
e) Existing travel characteristics	Details on the existing trip generation, modal split, and assignment of trips to the network
f) Proposal details	A description of the proposal (including site layout, operational hours, vehicle access, on site car parking and drop off, and internal vehicle and pedestrian circulation). A description of any construction management matters. A description of what end of journey facilities are proposed
g) Predicted travel data	<p>A description of the trip generation, modal split, trip assignment to the network, trip distribution and trip type proportions of the proposal. Consideration of future traffic volumes and trip generation. A 20-year assessment period for major arterial and strategic transport corridors should be used. Assessment periods shall be from date of application</p> <p>If relevant validated and comprehensive transportation forecasts are not available, the assessment should consider expected traffic conditions over a 10 year period and the sensitivity of assessment conclusions to changes in traffic condition.</p>
h) Appraisal of transportation effects	<p>An assessment of safety, efficiency, environmental, accessibility, integration and economic effects (including sensitivity testing). A specific assessment of the safety and efficiency of the transport network against Assessment Criteria G3 to G6 in Appendix 1.3.3 Restricted Discretionary, Discretionary and Non-Complying Assessment Criteria – G Transportation</p> <p>Where the proposed activity has the potential to impact on the state highway, a summary of consultation with the New Zealand Transport Agency shall be included</p>
i) Avoiding or mitigating actions	Details of any mitigating measures and revised effects, including measures to encourage other modes. Travel planning and travel demand management measures and sensitivity testing mitigations

Requirements for Broad ITA ¹	
Item description	Details to be included ²
j) Compliance with policy and other frameworks	Review against District Plan objectives, policies and rules. Detailed assessment against Access Hamilton and associated action plans. Other relevant local, regional and national strategies or plans (e.g. Regional Land Transport Strategy, Regional Public Transport Plan)
k) Safety and Efficiency	<p>Any changes over the relevant assessment period to the:</p> <ol style="list-style-type: none"> a. Predicted level of personal risk to individuals (safety) using the network. b. Levels of service (efficiency) of the network <p>Consideration of whether the desirable levels of service set out in the notes below can or should be maintained.</p> <p>This should also recognise the pre-proposal levels of service and whether other benefits accrue that could have the potential to offset or otherwise support a lesser level of service. For example, longer traffic delays resulting in slower speeds may support pedestrian-friendly land use environment in the Central City.</p>
l) Discussion and conclusions	An assessment of effects and conclusion of effects. Confirmation of the suitability of the location of the proposal
m) Recommendations	Proposed conditions (if any)

¹ For further guidance refer to Appendix A of New Zealand Transport Agency Research Report No.422 “Integrated Transport Assessment Guidelines”, Abley et al, November 2010.

² Details listed in bold font are required for large developments with significant transport impacts and may not be applicable for smaller developments.

Note

Guidance on ‘safety’ and ‘efficiency’

Desirable levels of service:

- i. An average delay per vehicle during Peak Periods on the approaches to intersections of no greater than:
 - 55 seconds for the Strategic Network, Major and Minor Arterial transport corridors
 - 80 seconds for all other transport corridors
- ii. On the Strategic Network, Major and Minor Arterial transport corridors during Peak Periods:
 - Average vehicle speeds between intersections restricted to no less than 90% of the posted speed limit
 - Average vehicle speeds, including intersections, constrained to no less than 18 km/h
- iii. Unless demonstrated otherwise with site specific data, Peak Periods are taken to be 7am to 9am and 4pm to 6pm Monday to Friday.

It is not a requirement of the Plan that individual proposals mitigate the effects of other proposals in order to achieve the desirable levels of service. Where the pre-proposal desirable levels of service over the assessment period have already been exceeded, it is not expected that a proposal be required to restore the network to the desirable levels of service, rather it is expected that the proposal mitigates its effects to maintain the pre-proposal level of service for the relevant assessment period.

Table 15-2c Downtown Precinct ITA Checklist

Requirements for ITA within Downtown Precinct ¹	
Item description	Details to be included ²
a) Background	A description of the proposed activity, the purpose and intended use of the ITA, and an outline of any previous discussions with the relevant road controlling authorities
b) Existing land data	A description of location, site layout, existing use and consents (if any)
c) Existing transport data	A description of the existing access and service arrangements and on-site car parking. A description of the transport network adjacent to the pedestrian and vehicle access points (including traffic volumes and crash analysis).
d) Committed environmental changes	Consideration of other developments, land use and transport network improvements within the Downtown Precinct (including passenger transport, walking and cycling)
e) Existing travel characteristics	Details on the existing trip generation, modal split, and assignment of trips to the network
f) Proposal details	A description of the proposal (including site layout, operational hours, vehicle access, on site car parking and drop off, and internal vehicle and pedestrian circulation). A description of what end of journey facilities are proposed
g) Predicted travel data	A description of the trip generation, modal split, trip assignment to the network, trip distribution and trip type proportions of the proposal. Consideration of future traffic volumes and trip generation using a 10-year assessment period.
h) Appraisal of transportation effects	An assessment of safety, efficiency, environmental, accessibility, and integration effects in the immediate vicinity.
i) Avoiding or mitigating actions	Details of any mitigating measures and revised effects, including measures to encourage other modes. Travel planning and travel demand management measures.
j) Compliance with policy and other frameworks	Review against District Plan objectives, policies and rules. Simple assessment against Access Hamilton and associated action plans.
k) Discussion and conclusions	An assessment of effects and conclusion of effects. Confirmation of the suitability of the access points of the proposal

Requirements for ITA within Downtown Precinct ¹	
Item description	Details to be included ²
l) Recommendations	Proposed conditions (if any)

¹ For further guidance refer to Appendix A of New Zealand Transport Agency Research Report No.422 “Integrated Transport Assessment Guidelines”, Abley et al, November 2010.

² Details listed in bold font are required for large developments with significant transport impacts and may not be applicable for smaller developments.

Table 15-2d: Integrated Transport Assessment vehicles per day conversion table

Activity	Threshold/unit equivalent to Vehicle Trip Generation				
	<100 vpd	100 - 249 vpd	250 - 499 vpd	500 – 1499 vpd	>1500 vpd
a) Ancillary residential units and apartment buildings	Up to 20 residential units	21-50 residential units	51-100 residential units	101-300 residential units	More than 300 residential units
b) Building improvement centre (excluding nurseries and garden centres)	Up to 100m ² GFA	101-250m ² GFA	251-500m ² GFA	501-1,500m ² GFA	More than 1500m ² GFA
c) Camping grounds	Up to 5,000m ² site area	5,001-12,500m ² site area	12,501-25,000m ² site area	25,001-75,000m ² site area	More than 75,000m ² site area
d) Childcare facilities	Up to 30 children	31-75 children	76-150 children	151-450 children	More than 450 children
e) Community centre	Up to 1,000m ² GFA	1,001-2,500m ² GFA	2,501-5,000m ² GFA	5,001-15,000m ² GFA	More than 15,000m ² GFA
f) Single dwellings and duplex dwellings	Up to 10 residential units	11-25 residential units	26-50 residential units	51-150 residential units	More than 150 residential units
g) Drive through services	All proposals require a Broad ITA				
h) Emergency service facilities	All proposals require an ITA				
i) Health care services	Up to 100m ² GFA	101-250m ² GFA	251-500m ² GFA	501-1,500m ² GFA	More than 1,500m ² GFA

Activity	Threshold/unit equivalent to Vehicle Trip Generation				
	<100 vpd	100 - 249 vpd	250 - 499 vpd	500 – 1499 vpd	>1500 vpd
j) Home-based business	ITA not required				
k) Hospitals	All proposals require a Broad ITA				
l) Industrial activities (including warehouses) (excluding trade and industry facilities)	Up to 1,500m ² GFA	1,501-3,750m ² GFA	3751-7,500m ² GFA	7,501-22,500m ² GFA	More than 22,500m ² GFA
m) Industrial activities (trade and industry facilities only)	Up to 500m ² GFA	501-1,250m ² GFA	1,251-2,500m ² GFA	2,501-7,500m ² GFA	More than 7,500m ² GFA
n) Managed care facilities and rest homes	Up to 15 beds	16-38 beds	39-75 beds	76-240 beds	More than 240 beds
o) Marae	Up to 1,000m ² GFA	1,001-2,500m ² GFA	2,501-5,000m ² GFA	5,001-15,000m ² GFA	More than 15,000m ² GFA
p) Nurseries and garden centres	Up to 65m ² GFA	66-175m ² GFA	176-400m ² GFA	401-1,500m ² GFA	More than 1,500m ² GFA
q) Offices	Up to 500m ² GFA	501-1,250m ² GFA	1,251-2,500m ² GFA	2,501-7,500m ² GFA	More than 7,500m ² GFA
r) Outdoor recreational areas including playing fields, courts and tracks	Up to 2 courts/fields	3-5 courts/fields	6-10 courts/fields	11-30 courts/fields	More than 30 courts/fields
s) Places of assembly (except Libraries and Museums)	Up to 1,000m ² GFA	1,001-2,500m ² GFA	2,501-5,000m ² GFA	5,001-15,000m ² GFA	More than 15,000m ² GFA
t) Places of Assembly (Libraries and Museums only)	Up to 150m ² GFA	151m ² -400m ² GFA	401m ² -750m ² GFA	751-2,200m ² GFA	More than 2,200m ² GFA

Activity	Threshold/unit equivalent to Vehicle Trip Generation				
	<100 vpd	100 - 249 vpd	250 - 499 vpd	500 – 1499 vpd	>1500 vpd
u) Places of worship	Up to 1,000m ² GFA	1,001m ² -2,500m ² GFA	2,501m ² -5,000m ² GFA	5,001-15,000m ² GFA	More than 15,000m ² GFA
v) Building serving recreation reserves and indoor recreation buildings	Up to 100m ² GFA	101-250m ² GFA	251-500m ² GFA	501-1,500m ² GFA	More than 1,500m ² GFA
w) Research and Innovation activities	Up to 500m ² GFA	501-1,250m ² GFA	1,251-2,500m ² GFA	2,501-7,500m ² GFA	More than 7,500m ² GFA
x) Residential centres	Up to 10 residents	11-25 residents	26-50 residents	51-150 residents	More than 150 residents
y) Retail activities (in individual ownership / tenancy or integrated retail development)	Up to 100m ² GFA	101-250m ² GFA	251-500m ² GFA	501-1,500m ² GFA	More than 1,500m ² GFA
z) Retail activities – Bulky goods only	Up to 100m ² GFA	101-250m ² GFA	251-500m ² GFA	501-1,500m ² GFA	More than 1,500m ² GFA
aa) Retail activities – Outdoor only	Up to 1,000m ² GFA	1,001-2,500m ² GFA	2501-5,000m ² GFA	5,001-15,000m ² GFA	More than 15,000m ² GFA
bb) Retail activities – Indoor display areas for vehicles, boats and agricultural and industrial machinery	Up to 1,500m ² GFA	1,501-3,750m ² GFA	3,751-7,500m ² GFA	7,501-22,500m ² GFA	More than 22,500m ² GFA
cc) Retail activities – Food and beverage, cafes, restaurants and licensed premises only	Up to 100m ² GFA	101-250m ² GFA	251-500m ² GFA	501-1,500m ² GFA	More than 1,500m ² GFA
dd) Retail activities – Supermarkets only	Up to 50m ² GFA	51-125m ² GFA	126-250m ² GFA	251-750m ² GFA	More than 750m ² GFA

Activity	Threshold/unit equivalent to Vehicle Trip Generation				
	<100 vpd	100 - 249 vpd	250 - 499 vpd	500 – 1499 vpd	>1500 vpd
ee) Retirement villages	Up to 1,200m ² GFA	1,201m ² - 3,000m ² GFA	3,001m ² - 6,000m ² GFA	6,001- 18,500m ² GFA	More than 18,500m ² GFA
ff) Schools	All proposals require a Broad ITA				
gg) Showhome	ITA not required				
hh) Tertiary education facilities and specialised training facilities	Up to 500m ² GFA	501-1,250m ² GFA	1,251-500m ² GFA	501-1,500m ² GFA	More than 7,500m ² GFA
ii) Transport depots	All proposals require a Broad ITA				
jj) Visitor accommodation	Up to 10 units	11-25 units	26-50 units	51-150 units	More than 150 units

15-3 Minimum Sight Distances at Railway Level Crossings – Tables and Figures

Table 15-3a: Required approach sight distances at railway level crossings¹

Vehicle approach speed (km/h) ^{2, 3}	Approach distance (A) ⁴	Required approach visibility along tracks (B) ^{4,5}		
		Signs only	Alarms only ⁶	Alarms and boom gates ⁶
20	31m	318m	Approach Sight Triangles not applicable in this situation	
30	50m	282m		
40	73m	274m		
50	100m	278m		
60	130m	287m		
70	164m	300m		
80	208m	314m		
90	251m	330m		
100	298m	357m		
110	350m	376m		

¹ This table is based on the sighting distance formula used in New Zealand Transport Agency Traffic Control Devices Manual 2008, Part 9 Level Crossings and in the Australian Level Crossing Assessment Model (ALCAM). Distances are conservative and are derived from:

- A train speed of 110 kph and a single set of rail tracks
- A fall of 8 % on the approach to the level crossing and a rise of 8 % at the level crossing
- 25 m design truck
- 90° angle between road and rail
- Other parameters as specified in New Zealand Transport Agency's Traffic Control Devices Manual 2008, Part 9 Level Crossings – Appendix B

² Speed restrictions are not used in New Zealand around level crossings

³ The 85th percentile road vehicle speed shall be adopted. This speed is typically estimated at the point at which a driver would first see the level crossing signs/alarms and begin to look for trains. Where this is not known, the sign-posted road speed + 10% shall be used

⁴ Refer to Figure 15-3b for how to define the Approach Sight Triangle using distance (A) and (B).

⁵ The distances in this table apply to a single set of rail tracks only. For each additional set of tracks add 25m to the distance (B).

⁶ Railway Level Crossings controlled by alarms or boom gates do not require approach sight triangles because they provide active warning signals of approaching trains.

Figure 15-3b: Measuring approach sight triangles at railway level crossings

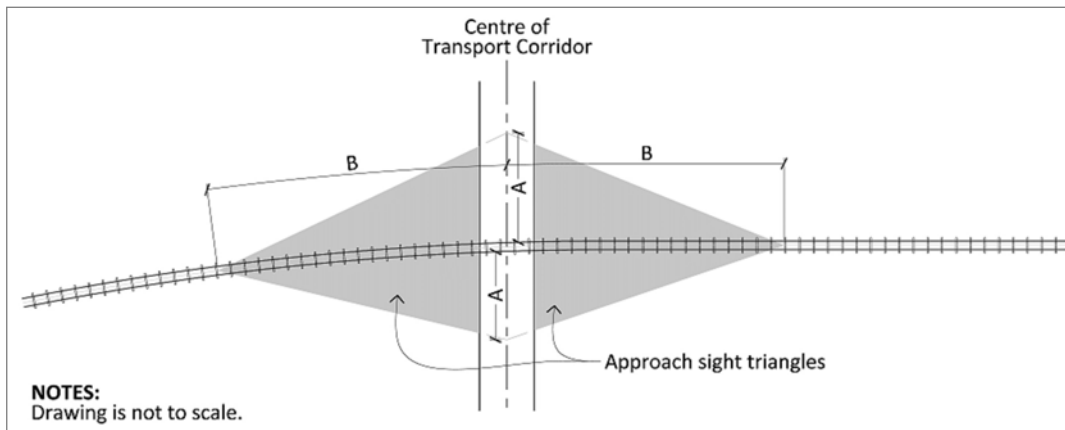

Table 15-3c: Required restart sight distances for railway level crossings¹

Required approach visibility along tracks (C) ^{2,3}		
Signs only ⁴	Alarms only ⁴	Alarms and boom gates ⁴
677m	677m	60m

¹ This table is based on the sighting distance formula used in New Zealand Transport Agency Traffic Control Devices Manual 2008, Part 9 Level Crossings and in the Australian Level Crossing Assessment Model (ALCAM). Distances are conservative and are derived from:

- A train speed of 110 kph and a single set of rail tracks
- A fall of 8 % on the approach to the level crossing and a rise of 8 % at the level crossing
- 25 m design truck
- 90° angle between road and rail
- Other parameters as specified in New Zealand Transport Agency’s Traffic Control Devices Manual 2008, Part 9 Level Crossings – Appendix B

² Refer to Figure 15-3d for how to define the Restart Sight Triangle using distance (C).

³ The distances in this table apply to a single set of rail tracks only. For each additional set of tracks add 50m to distance (C).

⁴ Type of Railway Level Crossing control.

Figure 15-3d: Measuring restart sight triangles at railway level crossings

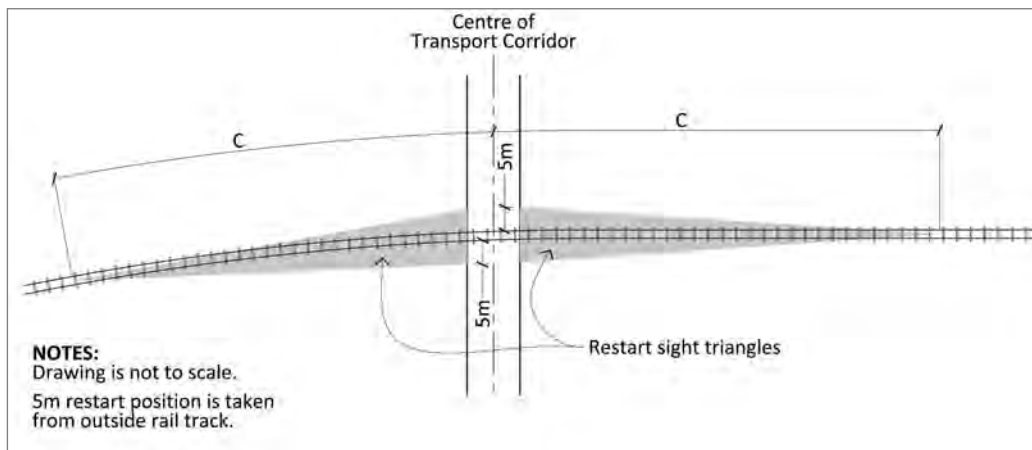

15-4 Transport Corridor Hierarchy Plan and Definitions

- a) The transport corridor hierarchy classifies current and planned future transport corridors within the City. The transport corridor hierarchy plan contained within Figures 15-4b to 15-4f identifies which classification applies to each transport corridor.
- b) Various standards within this Plan relate to the classification of transport corridors (e.g. building setbacks from an arterial transport corridor).

Function

- c) The hierarchy groups transport corridors into five main classifications based on the transportation functions they perform. These classifications are:
 - i. Major arterial.
 - ii. Minor arterial.
 - iii. Collector.
 - iv. Local.
 - v. Central City.
- d) A 'major arterial' transport corridor's principal function is the movement of significant levels of goods and people between parts of the City and beyond. Inter- and intra-city heavy freight and through traffic should generally be directed to these corridors. This classification includes all corridors managed as Motorway or Expressway by the New Zealand Transport Agency. Property access is either non-existent or heavily controlled. Inter-city passenger transport services are expected to use these routes. Intra-city passenger transport services may traverse these routes.
- e) A 'minor arterial' transport corridor's principal function is the movement of high levels of goods and people between parts of the City. Heavy freight distributing goods to parts of the City may use these corridors. Through-traffic moving between parts of the City may use these corridors. Property access is managed. Intra-city passenger transport services are likely to use these routes.
- f) A 'collector' transport corridor performs both a movement and property access function. These transport corridors often move goods and people between local destinations or to higher order transport corridors for further travel. Property access is provided with few restrictions. Depending on the land use environment heavy freight and through traffic may be limited on these corridors. Intra-city passenger transport services are likely to use these routes.
- g) A 'local' transport corridor's principal function is the provision of property access. The movement of goods and people is directed to higher-order transport corridors. Property access has few restrictions. The land-use environment dictates whether heavy freight movement is supported. Through-traffic is generally discouraged. Intra-city passenger transport services are unlikely to use these routes where an alternative higher-order transport corridor is available.
- h) 'Central City' transport corridors provide for both property access and the distribution of goods and people throughout, into and out of, the Central City.

Passenger transport services will use some of these corridors, particularly buses which provide services to and from the Hamilton Transport Centre. These corridors are expected to be used by significant numbers of commuters (vehicle, pedestrian and cyclists) and by service vehicles accessing properties or service lanes. High levels of visitor (e.g. shoppers, students) pedestrian traffic is also expected as people access goods and services and move about the Central City. On-street parking, loading, taxi, and bus stop facilities are common features.

- i) Two overlays are used to respond to factors that cross over the four classifications. These overlays are:
 - i. Strategic network.
 - ii. Pedestrian-focus areas.
- j) A strategic network applies to most major arterial transport corridors and generally includes the significant road corridors identified in the Regional Policy Statement and the Regional Land Transport Strategy. This overlay recognises the significant strategic role that these transport corridors perform for moving goods and people as part of the wider national and regional transport network. Protecting the efficient and effective operation of the strategic network so it can continue to provide its wider transport functions is a critical outcome.
- k) A pedestrian-focus area applies to specific transport corridors within the Central City. This reflects and supports the land-use pattern identified for the Central City. It is expected that the form of these transport corridors will evolve to support a complementary integration of the transport corridor function with the adjacent land uses. The design elements of these transport corridors will be more conducive to a vibrant, pedestrian-focused environment, supporting active frontages, on-street dining or retailing activities and the creation of high-quality public spaces.

Note

1. Shared zones (Land Transport (Road User) Rule 2004) or pedestrian malls (Section 336 of Local Government Act 1974) may be used as a means of managing the use of transport corridors in a way to give greater priority to pedestrian and cyclists. These mechanisms are very case specific and not likely to be applied generally to parts of the City. They are also unlikely to be appropriate outside of local transport corridors or Central City transport corridors within pedestrian-focus areas.

Form

- l) The form and design elements of transport corridors are determined through the balancing of a corridor's function within the network with the needs and sensitivities of adjacent land uses (see Land-Use Environments below).

Land-Use Environment

- m) 'Land-use environments' are groupings of land-use zones that provide for activities that share similar sensitivities to, or demands of, the transport network. These groups are defined in Table 15-4a. The land-use environments tend to affect the form of transport corridors by changing the allocation of space of various design elements (e.g. number of lanes, pedestrians, landscaping and other amenity features) and whether priorities are given to the different transport users or modes (e.g. desirable speed environment, shared spaces).

- n) The detail of the design elements and criteria for transport corridors is contained within Appendix 15-6. These design elements and the form created by the combination of transport corridor hierarchy classification and land-use environment, reflects a balancing process between the transport function demands and land use values (e.g. slower vehicle speeds and greater pedestrian amenity along local residential transport corridors).

Table 15-4a: Land-use environments by zone

Land-use environment	Zone ¹
a) Residential	General Residential Zone Special Residential Zone Special Heritage Zone Special Natural Zone Temple View Zone Residential Intensification Zone Peacocke Character Zone Rototuna North East Character Zone Medium Density Residential Zone Large Lot Residential Zone
b) Business	Business 1 to 7 Zones Knowledge Zone
c) Industrial	Industrial Zone Ruakura Logistics Zone Ruakura Industrial Park Zone Te Rapa North Industrial Zone
d) Future Urban	Future Urban Zone
e) Central City	Central City Zone
f) Site/Area specific ²	Community Facilities Zone Major Facilities Zone Neighbourhood Open Space Zone Sport and Recreation Open Space Zone Destination Open Space Zone Natural Open Space Zone

¹ Refer to the "Purpose of the Zone" of the relevant zone chapters for a statement about the purpose of each zone and the land-use activities they encourage or discourage.

² The location and extent of zones within this land-use environment category mean that transport corridors do not generally run through them. Transport corridors adjoining these land-use environments should reflect the land-use environment directly opposite these zones or be a continuation of the corridor either side. Site access controls may still vary.

Intersections

- o) The form and design elements of transport corridors may alter as they approach intersections. This is particularly the case where different classifications of transport corridors intersect and especially so where arterials meet lower-order transport corridors.
- p) To reinforce and protect the function of transport corridor classifications, the respective land-use environments, and the legibility of the network, intersections and their approaches may contain transport infrastructure or be managed in a way that would not normally be expected for that classification of transport corridor. For example, where a collector meets a major arterial the collector may: Gain additional lanes; have crossing infrastructure for pedestrians and cyclists; landscaping, public art or signs may be used to reinforce a change in hierarchy; or on-street parking may be restricted.

Routes Transitioning Between Land-Use Environments

- q) Some transport corridors are lengthy and pass through a range of land-use environments in the City. Along a corridor the classification or land-use environment may change. A logical evolution of the form of the transport corridor should be expected. This may be achieved by a substantial and immediate change at an appropriate intersection along the route, or possibly by gradual, progressive changes over a transitional length of the corridor.

Routes with Different Land-Use Environments on Each Side

- r) Parts of some transport corridors will have different zones on either side. In this situation the form of the transport corridor will need to be flexible to provide for the needs of both land-use environments.

Note

1. The Strategic Network Overlay is derived from transport corridors identified by:
 - The Regional Policy Statement 2016 – as Significant Transport Corridors
 - The Regional Land Transport Strategy 2011-2041 – as nationally or regionally significant
 - Access Hamilton – as part of the strategic network
2. The use of specific transport corridors for passenger transport (e.g. inter or intra city bus services) is determined by the Waikato Regional Council in collaboration with Council and expressed in the Regional Land Transport Strategy and Regional Public Transport Plan.
3. Some arterial transport corridors may also be limited access roads where access restrictions have been created under s88 of the Government Roading Powers Act 1989 or s346 of the Local Government Act 1974. These restrictions apply over and above any District Plan controls.
4. Access to transport corridors may also be restricted by segregation strips. Segregation strips are essentially small strips of land along the frontage of properties (even just a few centimetres wide) created under the Public Works Act 1981 (or by councils under the Local Government Act 2002) during property negotiations and/or application negotiations. The strips are held in public ownership and are not classed as being road. Properties separated from a transport corridor by a segregation strip lose their direct vehicle access to the transport corridor adjoining the segregation strip but are generally provided with alternative vehicle access.
5. Appendix 15-5 identifies land currently set aside for road but which Council intends to 'stop'.

Figure 15-4b: Transport corridor hierarchy plan

Proposed Plan Change 7:
Rotokauri North Private
Plan Change - Notified
Version

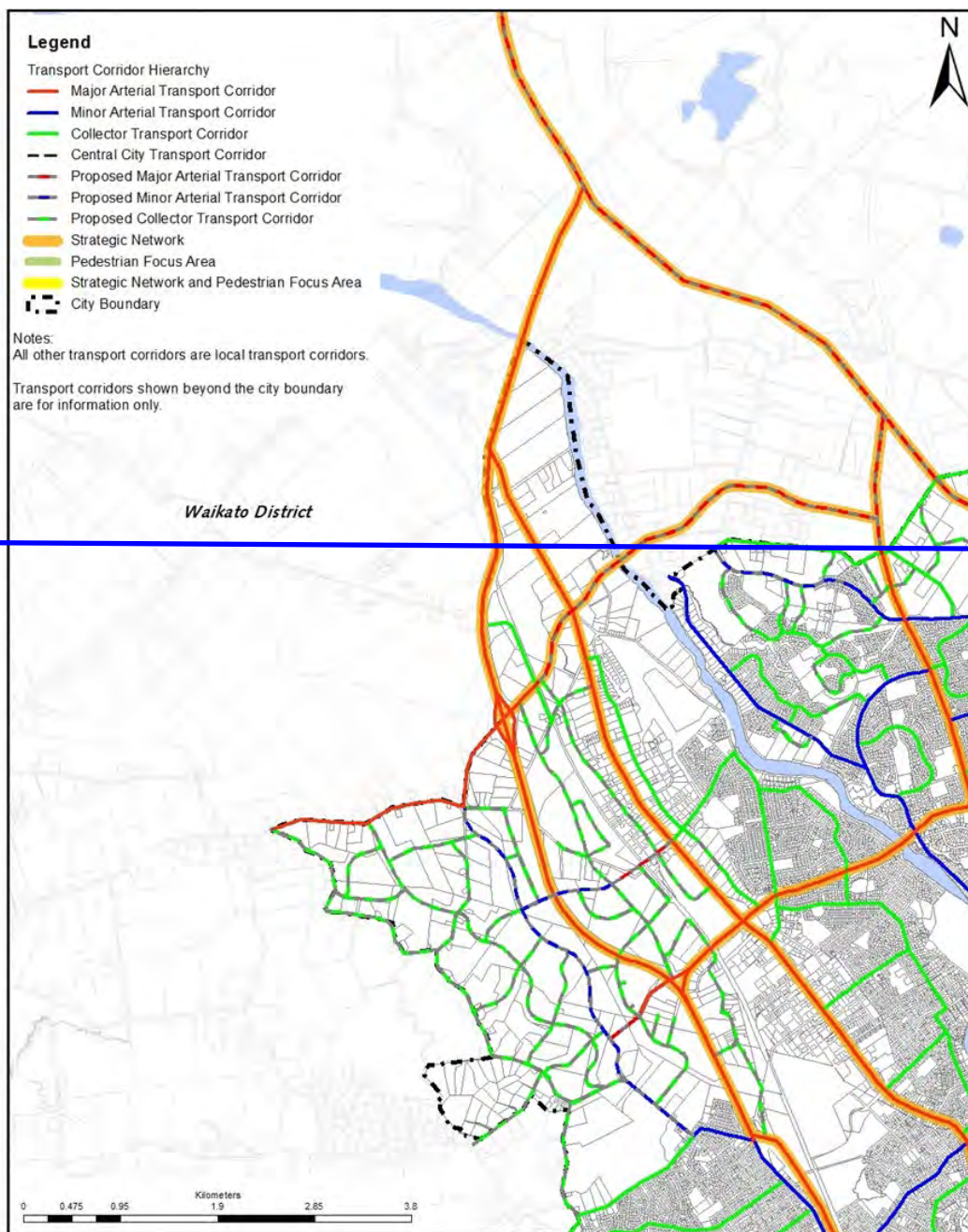

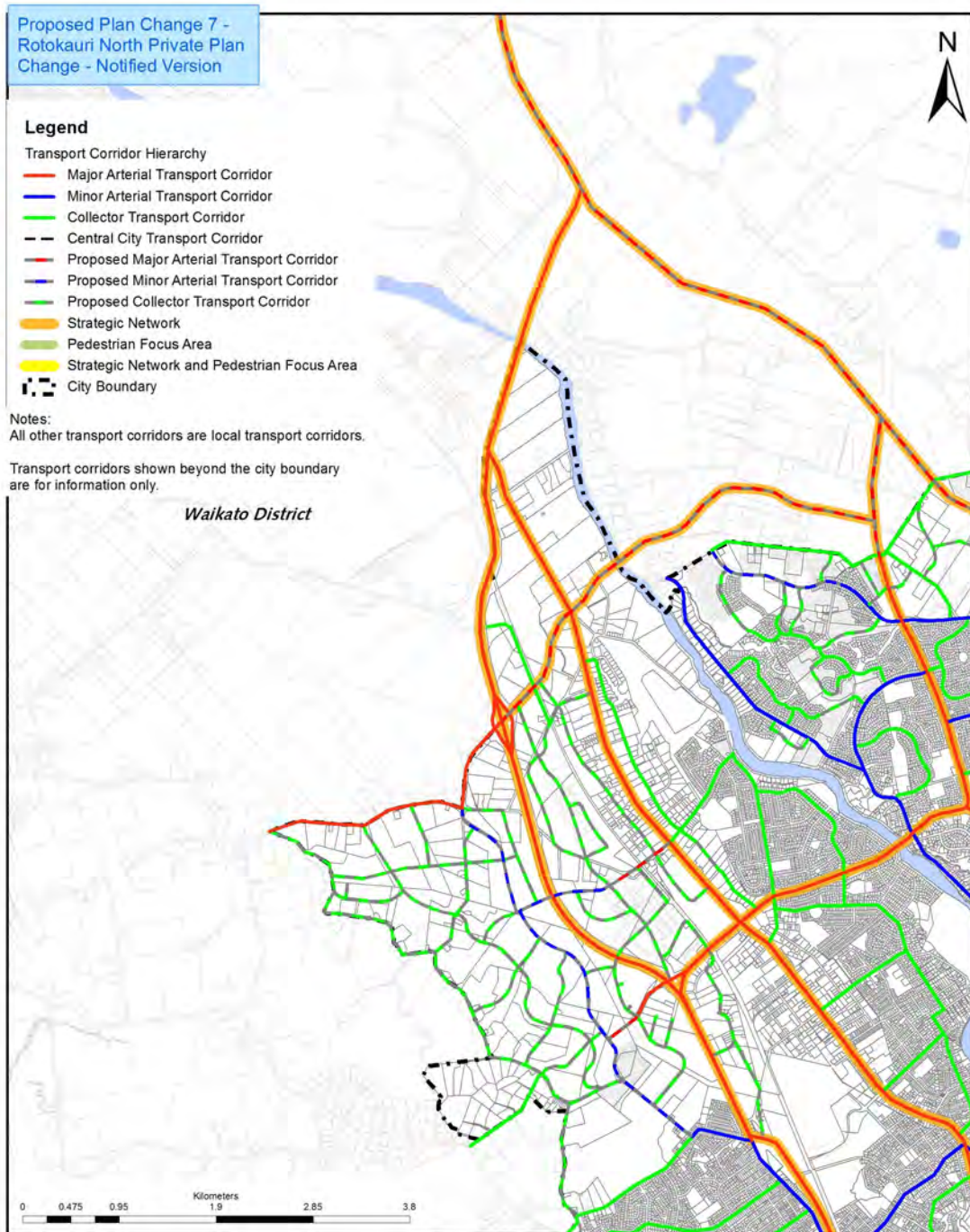

Figure 15-4c: Transport corridor hierarchy plan



Figure 15-4d: Transport corridor hierarchy plan

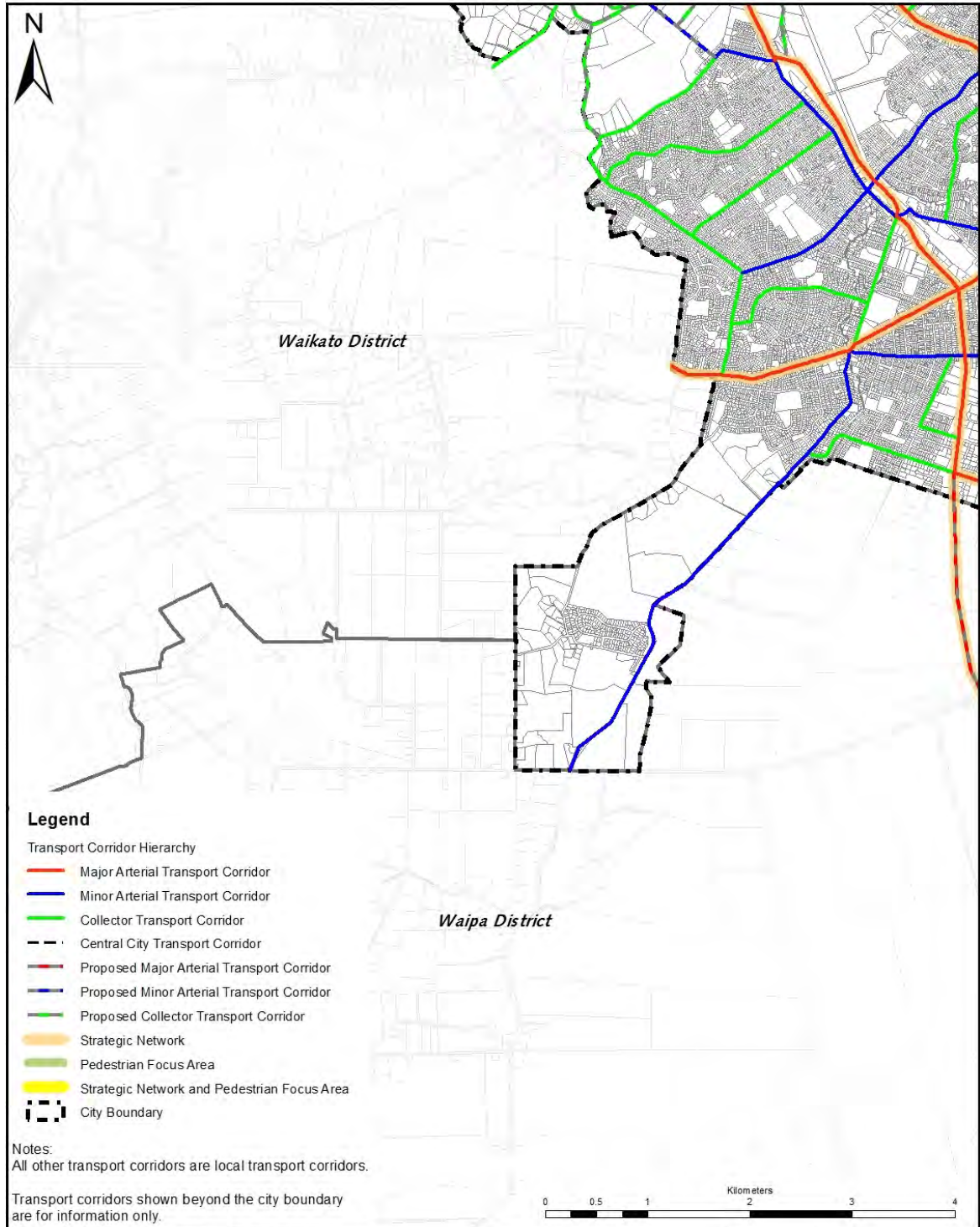
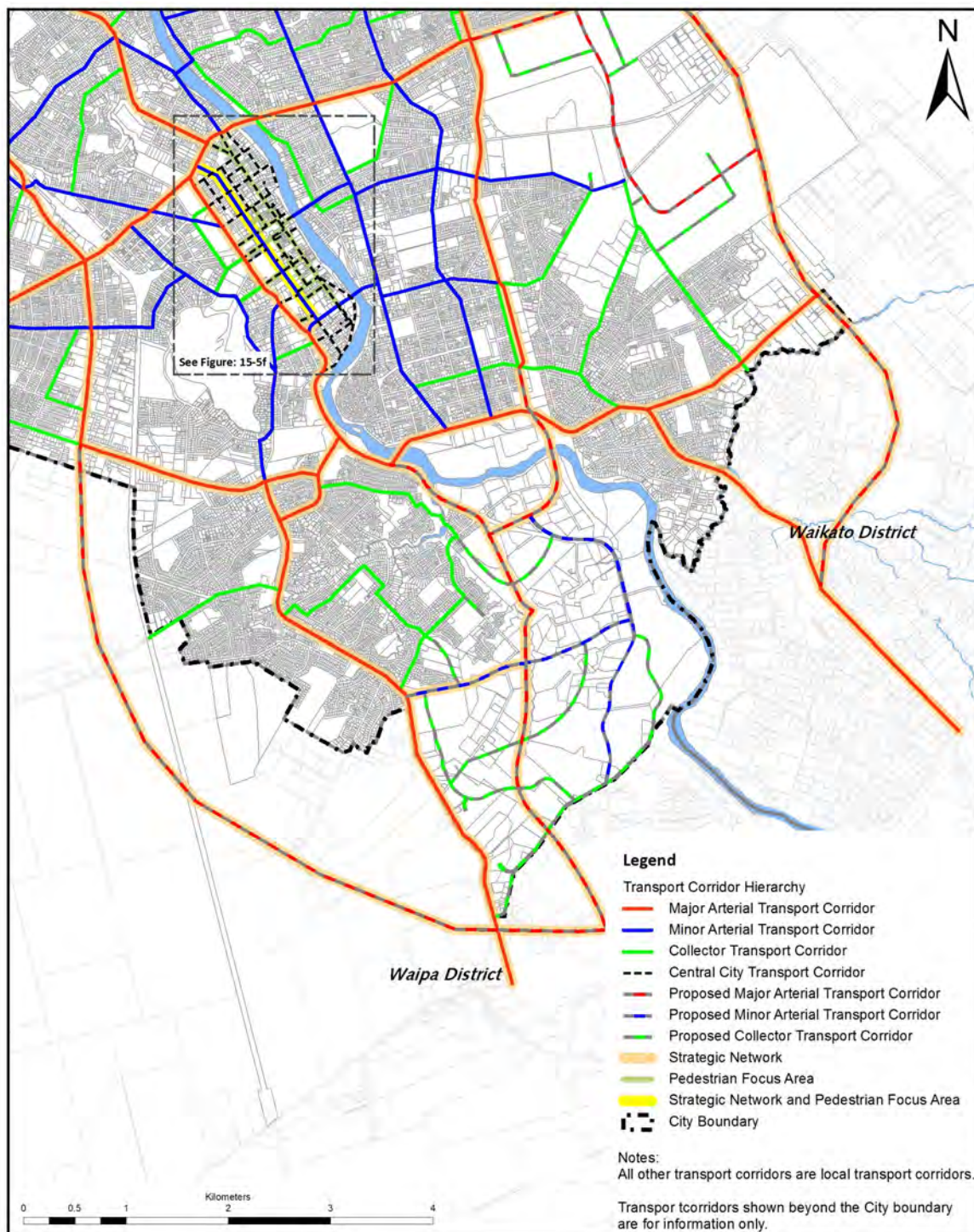

Figure 15-4e: Transport corridor hierarchy plan



15-5 Proposed Road Stopping

This appendix identifies land currently set aside for road but which Council intends to 'stop'. 'Stopping' means that it will cease to be road as defined by the Local Government Act. Road stopping is a process that can be undertaken under the Local Government Act 1974 or the Public Works Act 1981, and is separate to Resource Management Act processes, although sometimes they are run concurrently.

This appendix is for information purposes only and is not an exhaustive compilation of current or potential future road stopping. It is expected that road stopping processes, particularly the stopping of small parts of road, will arise and be processed without amendments being made to this appendix.

The areas shown are indicative and not surveyed. The final extent of any stopping will be determined as part of the formal stopping process.

Figure 15-5a

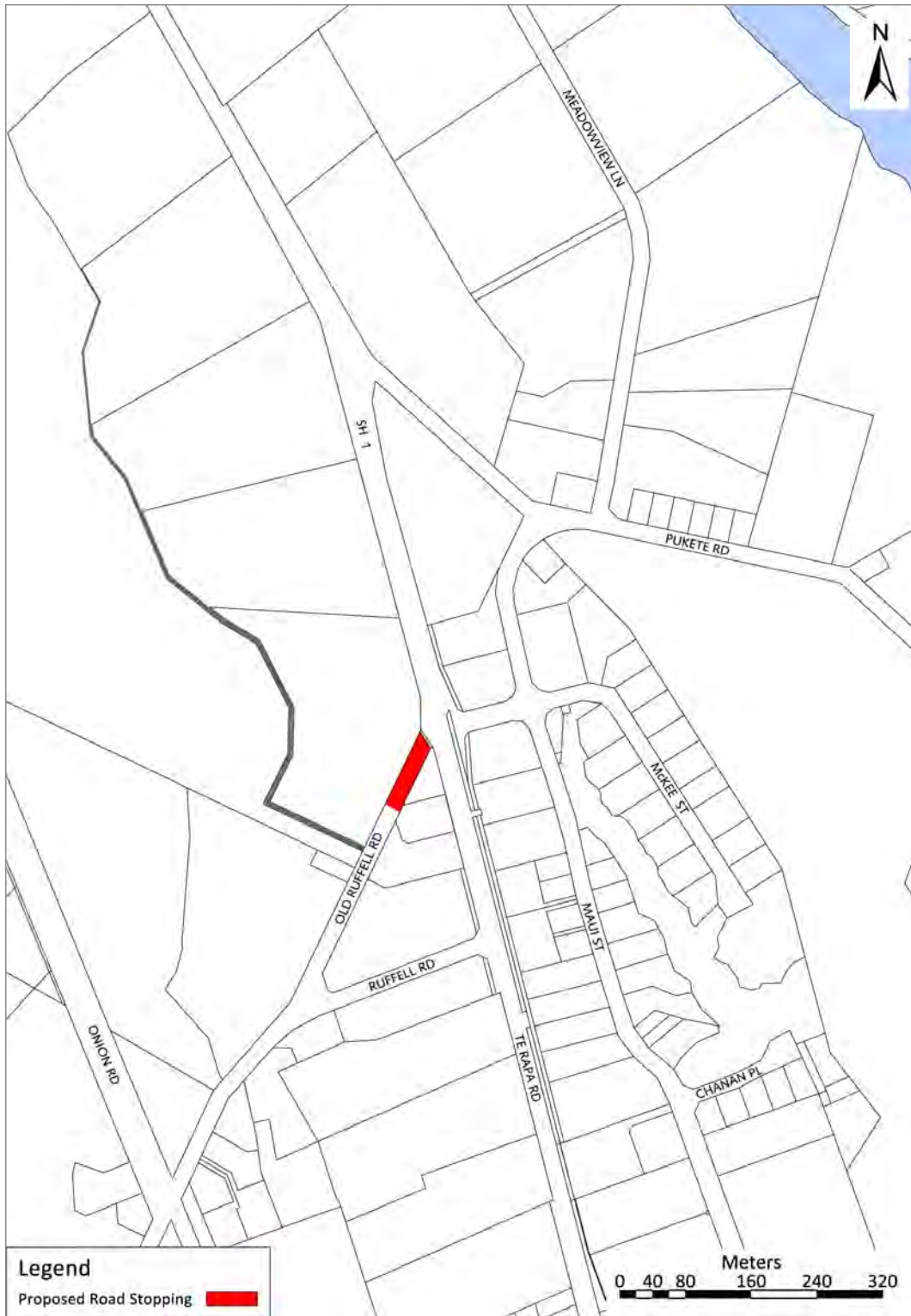

Figure 15-5b

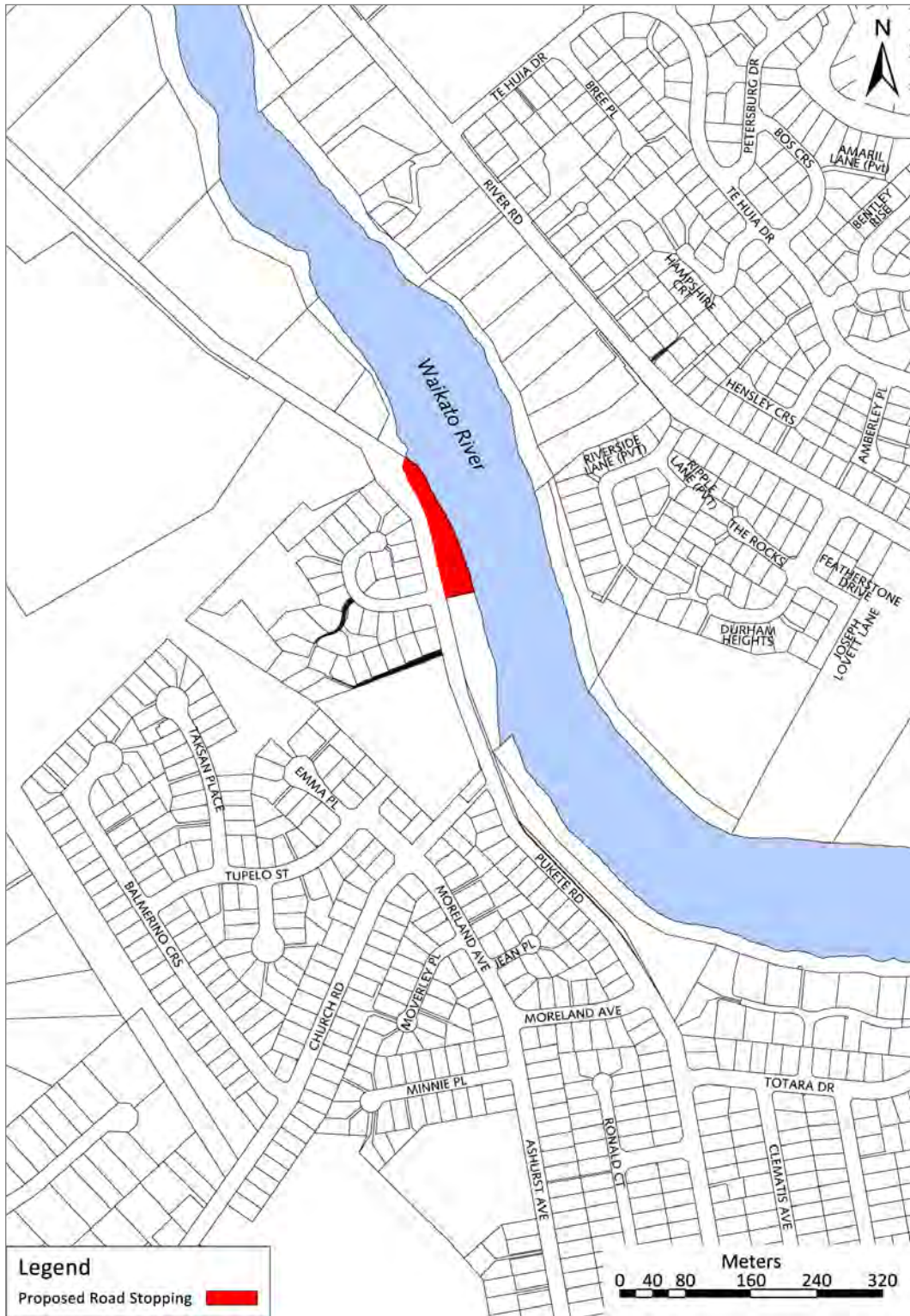

Figure 15-5c

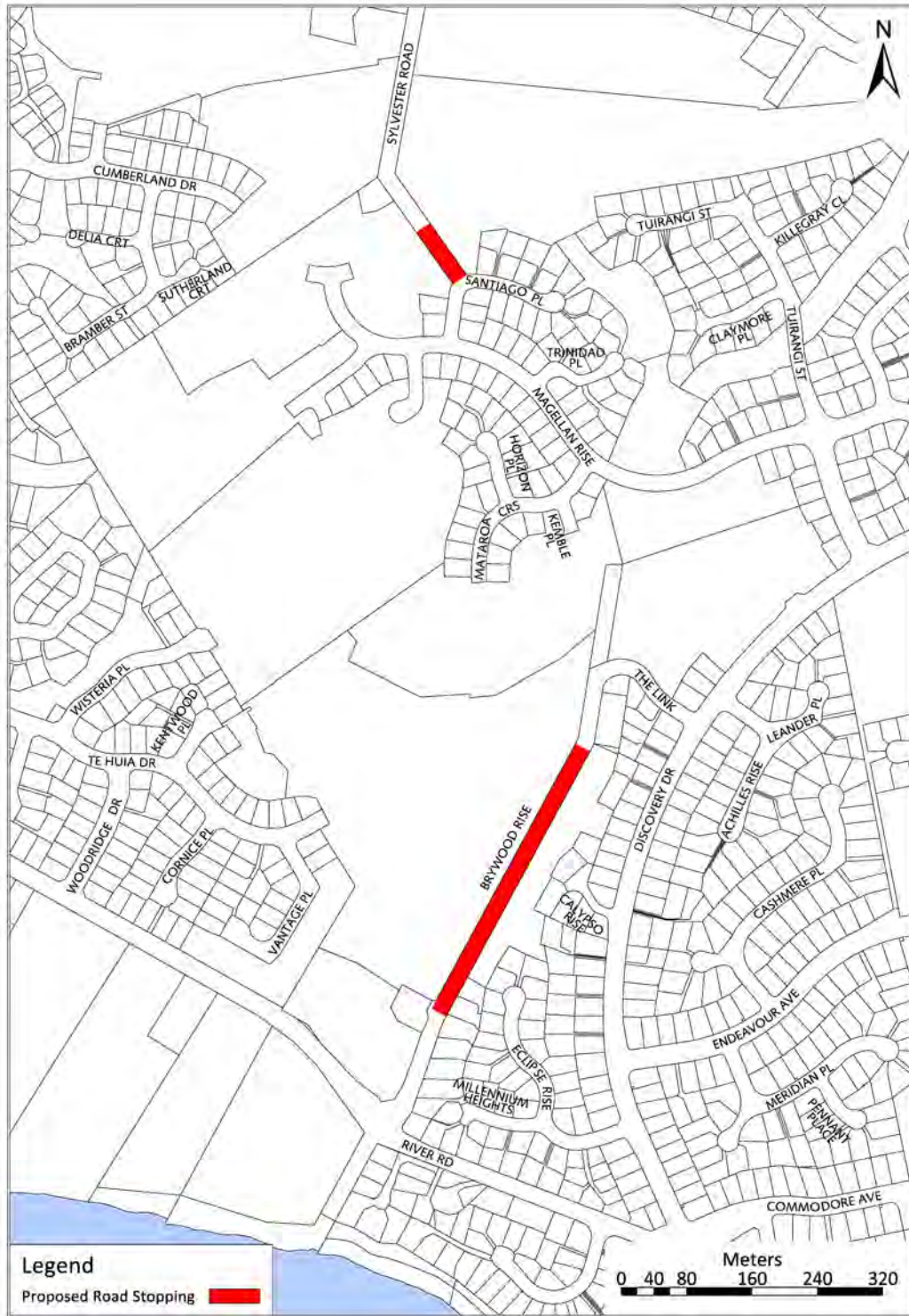

Figure 15-5d

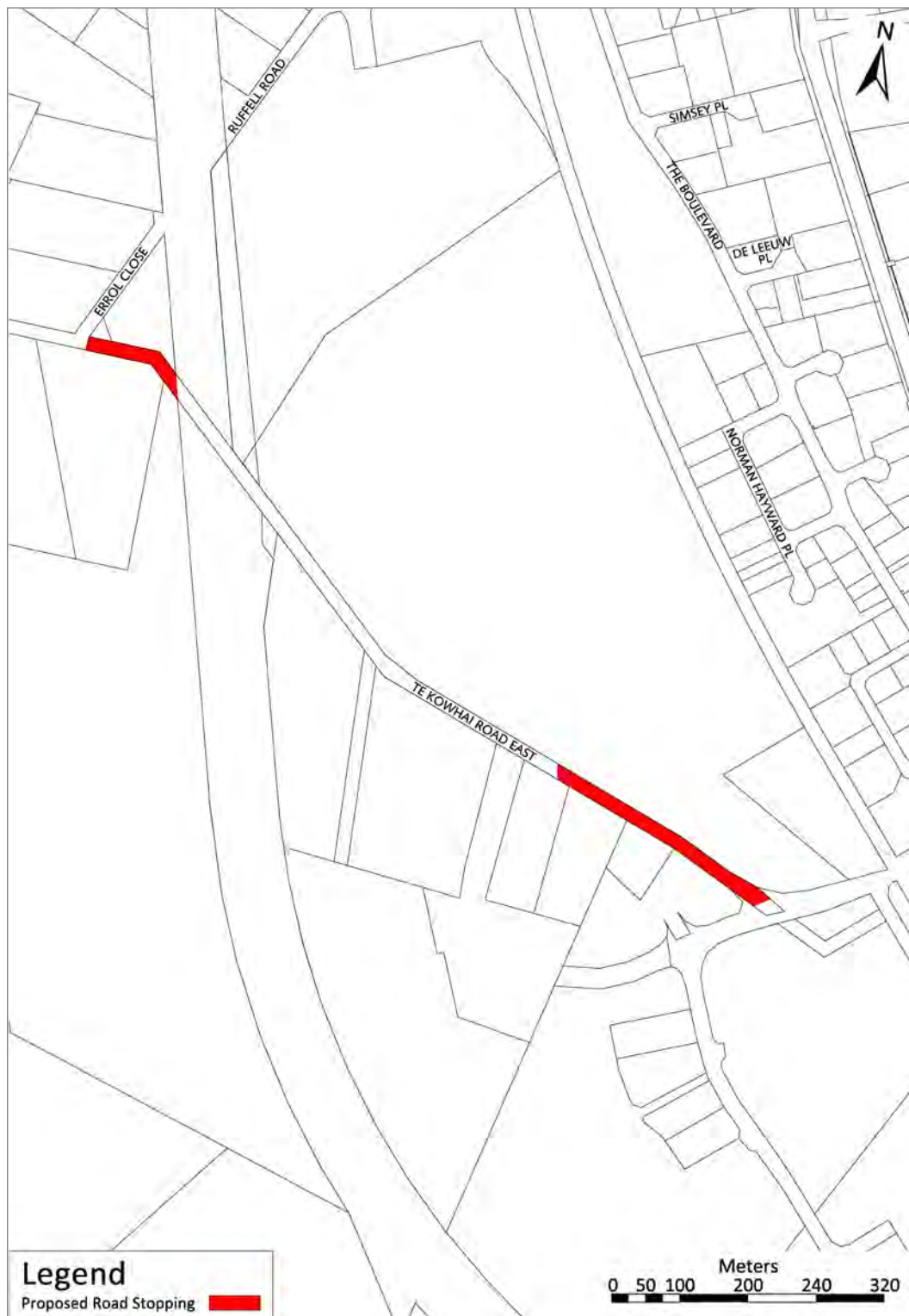

Figure 15-5e



Figure 15-5f



Figure 15-5g

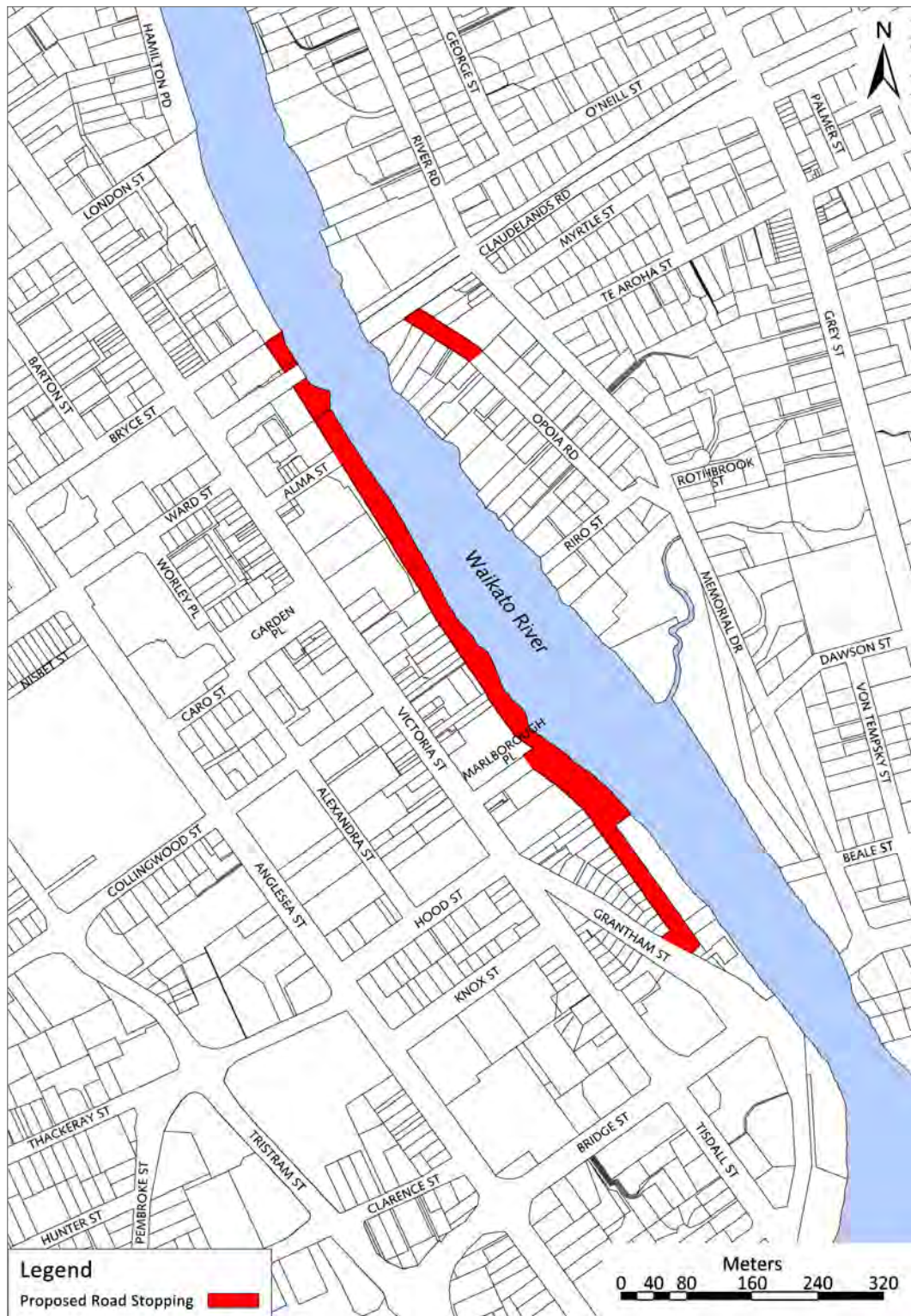

Figure 15-5h

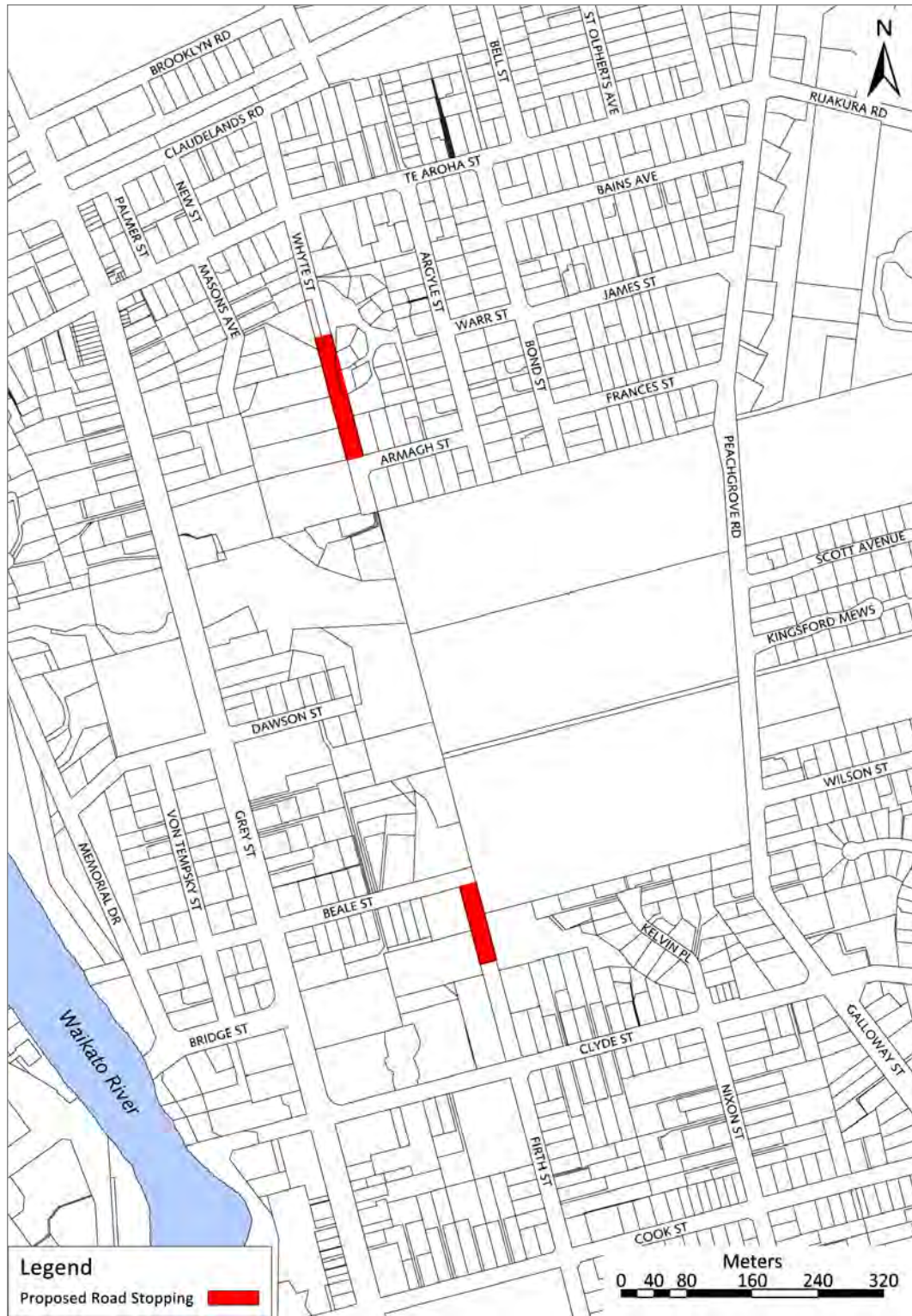

Figure 15-5i



Figure 15-5j

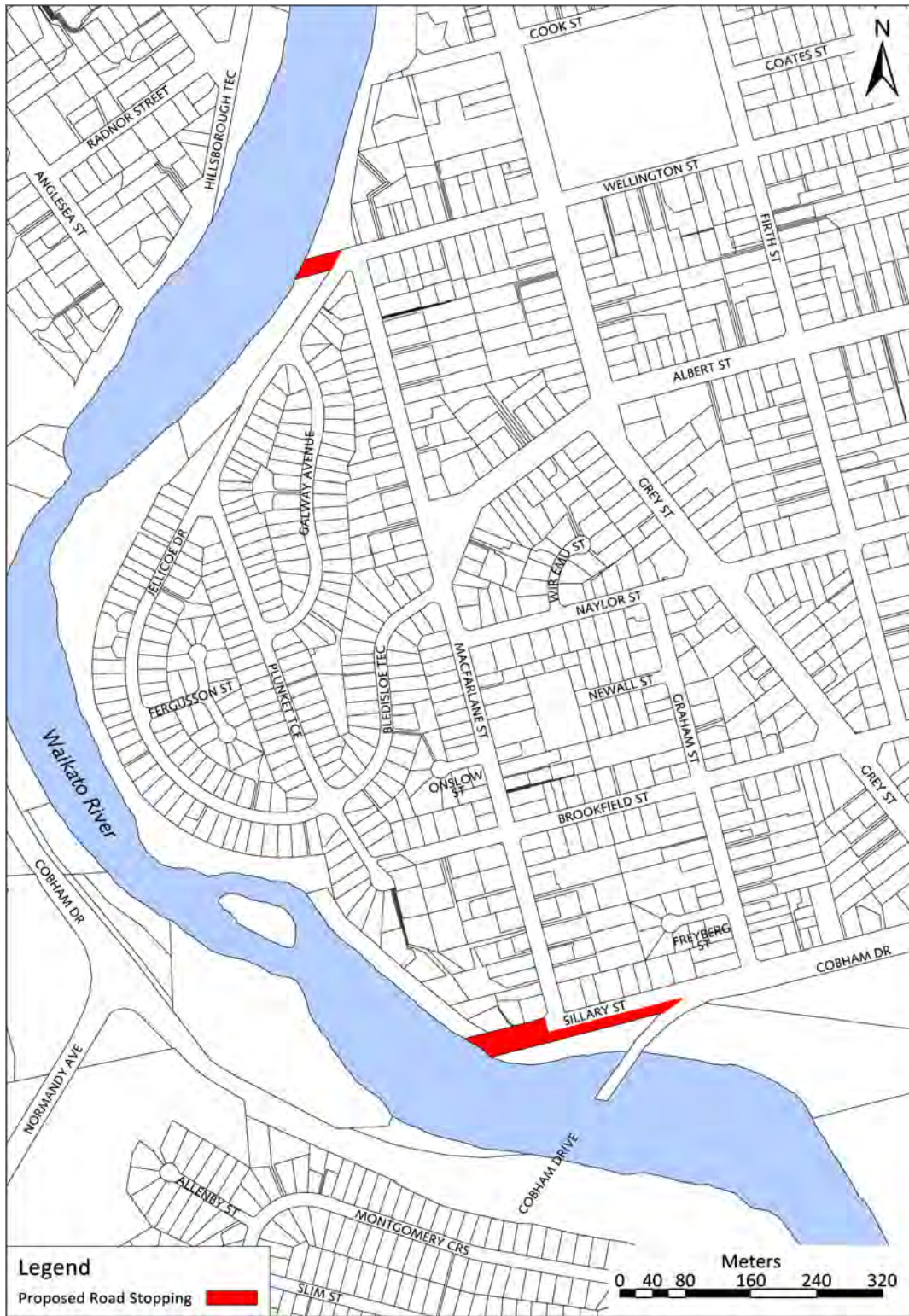

Figure 15-5k



15-6 Criteria for the Form of Transport Corridors and Internal Vehicle Access

For designations, new transport corridors, private ways and internal vehicle access the design elements in this table will be used as guidance.

For changes to existing transport corridors the design elements in this table are used to create a baseline within which new works are considered to be a permitted activity (refer to Chapter 18: Transport Corridor Zone).

The criteria on the following pages are based on the guidance contained in the Hamilton City Infrastructure Technical Specifications which can be referred to if necessary for clarification and interpretation.

Table 15-6a)i: Criteria for the form of Internal Vehicle Access

							Berm requirements ⁵				
Transport corridor type ¹	Land use environment ²	Design speed environment (max desirable)	Legal width (min desirable) ⁴ 5, 14	Carriageway width ³	Movement lane width ¹⁵	Berm requirements ⁵	On street parking requirements (min desirable)	Passenger transport requirements (min desirable) ¹¹	Footpath requirements (min desirable) ¹²	Cyclepath requirements (min desirable)	Service corridor (min desirable) ⁶
Residential Land Use Environment											
Private Way	Residential (serving 1-6 units)	10km/h	3.6m	3m	2-way flow, not marked	One side	None	None	Shared zone	Shared zone – no dedicated facility	One side
Private Way	Residential (serving 7-20 units – via common property under unit Titles Act) or, 7 – 9 units (where access is part of a fee simple subdivision)	10 to 20km/h	6m	5.5m	2-way flow, not marked	1.5m both sides	None	None	Shared zone	Shared zone – no dedicated facility	1.5m both sides

Table 15-6a)ii: Criteria for the form of Transport Corridors

Transport corridor type ¹	Land use environment ²	Design speed environment (max desirable)	Legal road width (min desirable) ^{4, 5, 14}	Carriageway width ³	Movement lane width ¹⁵	Berm requirements ⁵	Berm requirements ⁵				
							On street parking requirements (min desirable)	Passenger transport requirements (min desirable) ¹¹	Footpath requirements (min desirable) ¹²	Cyclepath requirements (min desirable)	Service corridor (min desirable) ⁶
Residential Land Use Environment											
Local (low volume)	Residential (serving 10-20 units via fee simple tenure)	40km/h	16m	6m	2 way flow, not marked	5m both sides	Recessed parallel parking bays (2m) on both sides	None	1.5m wide footpath, both sides	Cycling on road shared in movement lane	1.5m both sides
Local	Residential	40km/h	20m	6m	2 way flow, not marked	7m both sides	Recessed parallel parking bays (2m) on both sides	None	1.5m wide footpath, both sides	Cycling on road shared in movement lane	1.5m both sides
Collector	Residential	40 to 50km/h	23m	9m	2 @ 3m, marked	7m both sides	Recessed parallel parking bays (2m) on both sides	All bus stops to be kerbside ¹¹	2m wide footpath, both sides	1.5m on road marked cycle lane, both sides	2m both sides

Minor Arterial	Residential (Managed or limited direct access) ¹⁰	60km/h	Specific design ⁸	Specific design ⁸	2 @ 3.5m, marked, plus 3m flush median	Specific design ⁸	Recessed parallel parking bays (2m) on both sides	All bus stops to be kerbside. Potential for bus priority at intersections	3m shared off road footpath and cyclepath on both sides	2.5m both sides
Major Arterial	Residential (Limited or no direct access) ¹⁰	80km/h	Specific design ⁸	Specific design ⁸	4 @ 3.5m, marked, plus 3m solid median	Specific design ⁸	None	All bus stops to be recessed. Potential for bus priority at intersections	3m shared off road footpath and cyclepath on one side	Specific design ⁸

Industrial Land Use Environment											
Local	Industrial	40km/h	20m	9m	2 @ 4.5m, not marked	5.5m both sides	Recessed parallel parking bays (2m) on both sides	None	1.5m wide footpath, both sides	Cycling on road shared in movement lane	1.5m both sides
Collector	Industrial	40km/h	23m	11m	2 @ 4.5m, marked, plus 2m flush median	6m both sides	Recessed parallel parking bays (2m) on both sides	All bus stops to be kerbside	1.5m wide footpath, both sides	Cycling on road shared in movement lane	2m both sides
Minor Arterial	Industrial	60km/h	Specific design ⁸	12m Specific design ⁸	2 @ 4.5m, marked, plus 3m flush median	Specific design ⁸	Recessed parallel parking bays (2m) on both sides	All bus stops to be kerbside	3m shared off road footpath and cyclepath on one side and a 1.5m footpath on the other		2.5m both sides

Major Arterial	Industrial	80km/h	Specific design ⁸	Specific design ⁸	4 @ 3.5m, marked, plus 3m solid median	Specific design ⁸	None	All bus stops to be recessed	3m shared off road footpath and cyclepath on one side	Both sides (subject to specific design ⁸)	
Business Centres Land Use Environment											
Service Lane	Business Centres	10km/h	9m	5m	2 way flow, not marked	Specific design ⁸	None	None	Shared zone	Shared zone – no dedicated facility	1.5m both sides
Local	Business Centres	40km/h ⁷	Specific design ⁸	12m (subject to specific design ⁸)	2 @ 3m	Specific design ⁸	Parking one side only. May be recessed, parallel or angled	All bus stops to be kerbside	2 @ 3.5m (subject to specific design ⁸)	Cycling on road shared in movement lane (subject to specific design ⁸)	1.5m both sides (subject to specific design ⁸)

Table 15-6a)ii: Criteria for the form of Transport Corridors

Transport Corridor Type ¹	Land Use Environment ²	Design Speed Environment (max desirable)	Legal Road width (min desirable) ^{4, 5, 14}	Carriageway Width ³	Movement Lane Width ¹⁵	Berm Requirements ⁵	Berm Requirements ⁵				
							On street parking requirements (min desirable)	Passenger Transport requirements (min desirable) ¹¹	Footpath requirements (min desirable) ¹²	Cyclepath requirements (min desirable)	Service Corridor (min desirable) ⁶
Collector	Business Centres	40km/h ⁷	Specific design ⁸	Specific design ⁸	2 @ 3.5m plus median	Specific design ⁸	Specific design ⁸ . Parking and loading spaces recessed. Parking may be parallel or angled on both sides	All bus stops to be kerbside	2 @ 3.5m (subject to specific design ⁸)	Cycling on road shared in movement lane (subject to specific design ⁸)	2m both sides (subject to specific design ⁸)
Minor Arterial	Business Centres	60km/h ⁷	Specific design ⁸	Specific design ⁸	Specific design ⁸	Specific design ⁸	Specific design ⁸ . Typically recessed parallel parking bays (2m) on both sides	All bus stops to be kerbside	2 @ 3.5m (subject to specific design ⁸)	Cycling lanes both sides (subject to specific design ⁸)	2.5m both sides (subject to specific design ⁸)
Major Arterial	Business Centres	60km/h ⁷	Specific design ⁸	Specific design ⁸	Specific design ⁸	Specific design ⁸	Specific design ⁸ . Typically no on street parking provided	All bus stops to be kerbside. Potential for bus priority at intersections	3m, shared off road footpath and cyclepath, both sides		Both sides (subject to specific design ⁸)

Transport Corridor Type ¹	Land Use Environment ²	Design Speed Environment (max desirable)	Legal Road width (min desirable) ^{4, 5, 14}	Carriageway Width ³	Movement Lane Width ¹⁵	Berm Requirements ⁵	Berm Requirements ⁵				
							On street parking requirements (min desirable)	Passenger Transport requirements (min desirable) ¹¹	Footpath requirements (min desirable) ¹²	Cyclepath requirements (min desirable)	Service Corridor (min desirable) ⁶
Future Urban Land Use Environment											
Local	Future Urban ⁹	40km/h	Specific design ⁸ (no less than 20m)	8m	2 @ 3m plus 2 @ 1m shoulder	Specific design ⁸	None	None	1.5m wide footpath, both sides	Cycling on road shared in movement lane	Both sides
Collector	Future Urban ⁹	60 or 80km/h	Specific design ⁸ (no less than 23m)	9m	2 @ 3m plus 2 @ 1m shoulder	Specific design ⁸	None	All bus stops to be recessed	2.5m, shared off road footpath and cyclepath, both sides		Both sides
Minor Arterial	Future Urban ⁹	60km/h	Specific design ⁸	Specific design ⁸	Specific design ⁸	Specific design ⁸	Specific design ⁸	Specific design ⁸	Specific design ⁸	Specific design ⁸	Specific design ⁸
Major Arterial	Future Urban ⁹	80km/h	Specific design ⁸	Specific design ⁸	Specific design ⁸	Specific design ⁸	Specific design ⁸	Specific design ⁸	Specific design ⁸	Specific design ⁸	Specific design ⁸
Central City Land Use Environment											
Central City	Central City	30km/h	Specific design ⁸	Specific design ⁸	Specific design ⁸	Specific design ⁸	Parking and loading spaces to be separate and recessed	All bus stops to be kerbside	2 @ 4m (subject to specific design ⁸)	Cycling on road shared in movement lane	Both sides
Pedestrian Focus Area	Central City	30km/h	Specific design ⁸	Specific design ⁸	Specific design ⁸	Specific design ⁸	Parking and loading spaces to be separate and recessed	Specific design ⁸ . All bus stops to be kerbside	2 @ 4m (subject to specific design ⁸)	Cycling on road shared in movement lane	Both sides

Transport Corridor Type ¹	Land Use Environment ²	Design Speed Environment (max desirable)	Legal Road width (min desirable) ^{4, 5, 14}	Carriageway Width ³	Movement Lane Width ¹⁵	Berm Requirements ⁵	Berm Requirements ⁵				
							On street parking requirements (min desirable)	Passenger Transport requirements (min desirable) ¹¹	Footpath requirements (min desirable) ¹²	Cyclepath requirements (min desirable)	Service Corridor (min desirable) ⁶
Strategic Network and Pedestrian Focus Area (Anglesea St)	Central City	40km/h	Specific design ⁸	Specific design ⁸	Specific design ⁸	Specific design ⁸	Parking and loading spaces to be separate and recessed	Specific design ⁸ Potential for bus lanes and priority at intersections	Specific design ⁸	Specific design ⁸	Both sides
Strategic Network (Tristram St [Mill St to Bridge St] and Mill St)	Central City	60km/h	Specific design ⁸	Specific design ⁸	Specific design ⁸	Specific design ⁸	None	Potential for bus priority at intersections	Specific design ⁸	Specific design ⁸	Both sides
Strategic Network Overlay											
Strategic Network	All	60 or 80km/h	Specific design ⁸	Specific design ⁸	Specific design ⁸	Specific design ⁸	Specific design ⁸	Specific design ⁸ Potential for bus priority at intersections	Specific design ⁸	Specific design ⁸	Specific design ⁸

- ¹ New Major and Minor Arterial transport corridors are likely to be designated with the final design undertaken on a case by case basis. For work involving significant changes to existing transport corridors, local constraints, land use environment and network function requirements may require design compromises whereby the minimum desirable design criteria may not be able to be met. Refer to Figures 15-4b to 15-4f to identify the relevant transport corridor type.
- ² Refer to Table 15-4a for which zones form land use environments.
- ³ Measured from the face of the kerb to the face of the opposite kerb (excluding any recessed parking).
- ⁴ Full transport corridor width.
- ⁵ Measured from the property boundary to the face of the kerb. Berm width will vary in order to accommodate features as required, including: lighting, noise attenuation, landscaping, street trees, swale drains, footpaths, cyclepaths, recessed parking. Landscaping or street trees will require a minimum width of 2m and be incorporated into the legal road width (typically replacing indented parking or medians).
- ⁶ Location of services will be dependent upon the location of the footpath. The Hamilton City Infrastructure Technical Specifications contains relevant guidance on locating services.
- ⁷ If high pedestrian activity is expected then a 30km/h (or lower) design speed environment will be required. An Integrated Transport Assessment and safety audits will be necessary to ensure that the safety of vulnerable transport corridor users is achieved.
- ⁸ Specific design requires case by case consideration of the design elements in the local context. This must be undertaken with input from Council's City Infrastructure engineers.
- ⁹ The design of transport corridors in the Future Urban land use environments should be flexible enough to enable retrofitting to a lower design speed environment should zoning of the adjacent land use change.
- ¹⁰ The level of direct access (none, limited, managed) may vary along a corridor depending on network function requirements, topography and the availability of alternative access.
- ¹¹ For guidance on bus stop types refer to the Hamilton City Infrastructure Technical Specifications. The design of kerbside bus stops will result in the positioning of a stopped bus partially or fully within the cycle or movement lane. This may require kerb extensions to achieve. Bus stops are only necessary if part of a bus route.
- ¹² For guidance on pedestrian crossing facilities refer to the Hamilton City Infrastructure Technical Specifications.
- ¹³ Refer to 'Design Speed Environment' below for further guidance.
- ¹⁴ Stormwater management solutions may require additional legal road width and alter the arrangement of elements in this table (e.g. swales or space for treatment devices).
- ¹⁵ Excluding shoulders.

Figure 15-6b

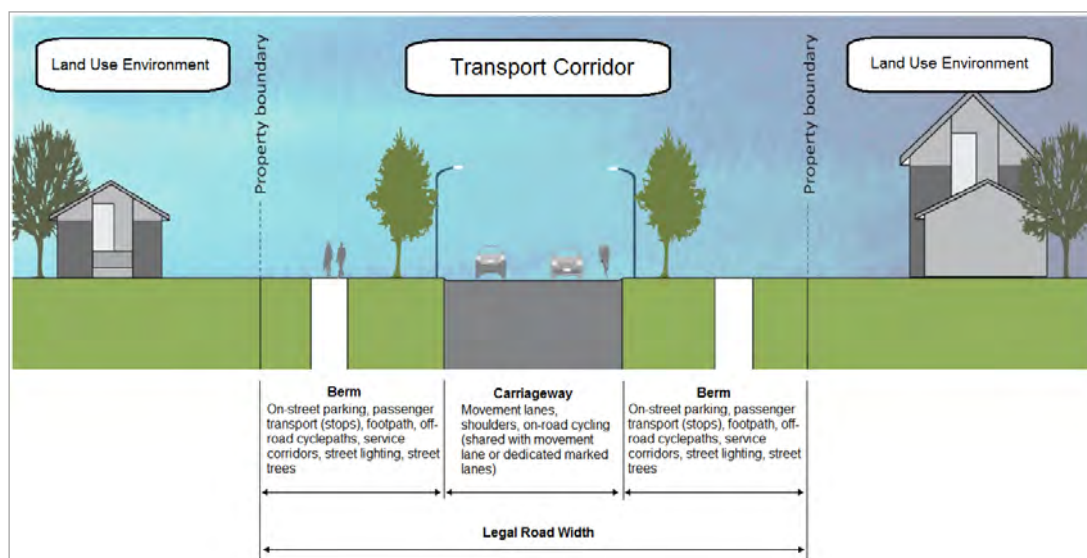

Design Speed Environment

Traffic management will need to be included in transport corridor designs to ensure that the design speed environment shown in Table 15-6a is achieved.

Speeds can be managed by physical and psychological devices such as narrowed movement lanes, reduced forward visibility, parking, slow points, build outs, leg lengths, chicanes, planting and landscaping, and street furniture and public art works.

Suitable guidance for designing to a design speed environment can be found in:

- The Austroads Guide to Road Design – Part 3: Geometric
- The Manual for streets (UK Department for Transport 2007)

The two key geometric factors that contribute to achieving the target operating speed are carriageway width and forward visibility. Figure 15-6c can be used to give an indication of the speed at which traffic will travel for a given carriageway width/forward visibility combination.

Figure 15-6c: Design speed environment – relationship between carriageway width and forward visibility

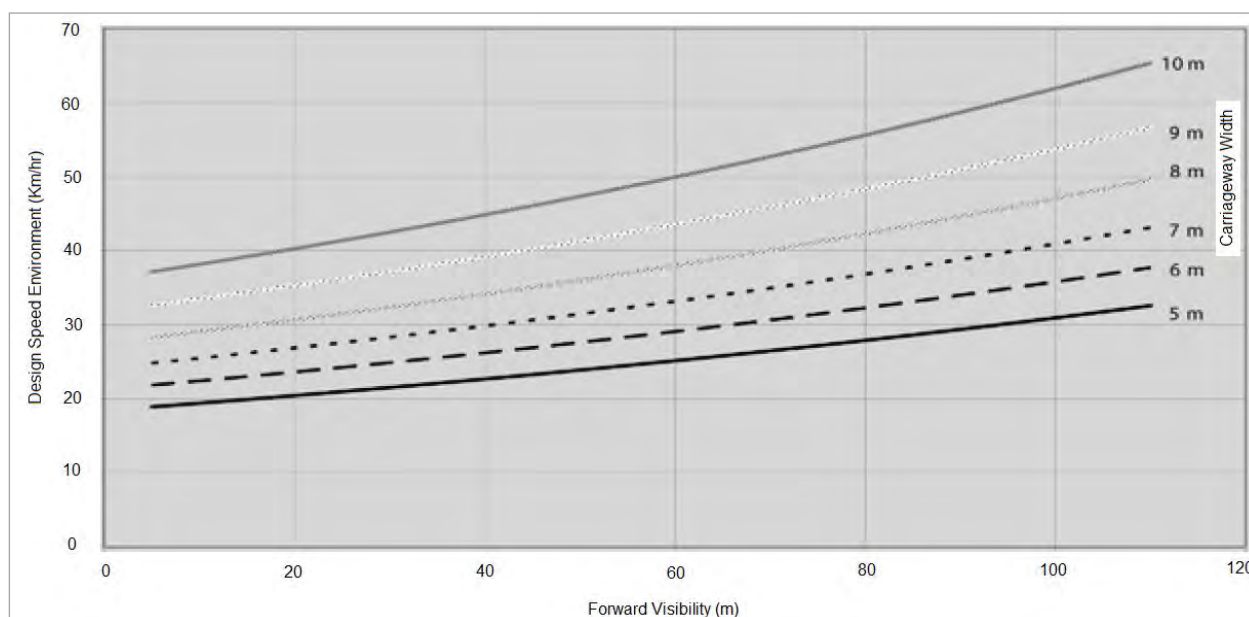

Source: Adapted from figure 7.16 of UK Department for Transport 'Manual for streets' and 'TRL661 - The manual for streets: evidence and research'

15-7 Area Specific ITA Requirement

Figure 15-7a

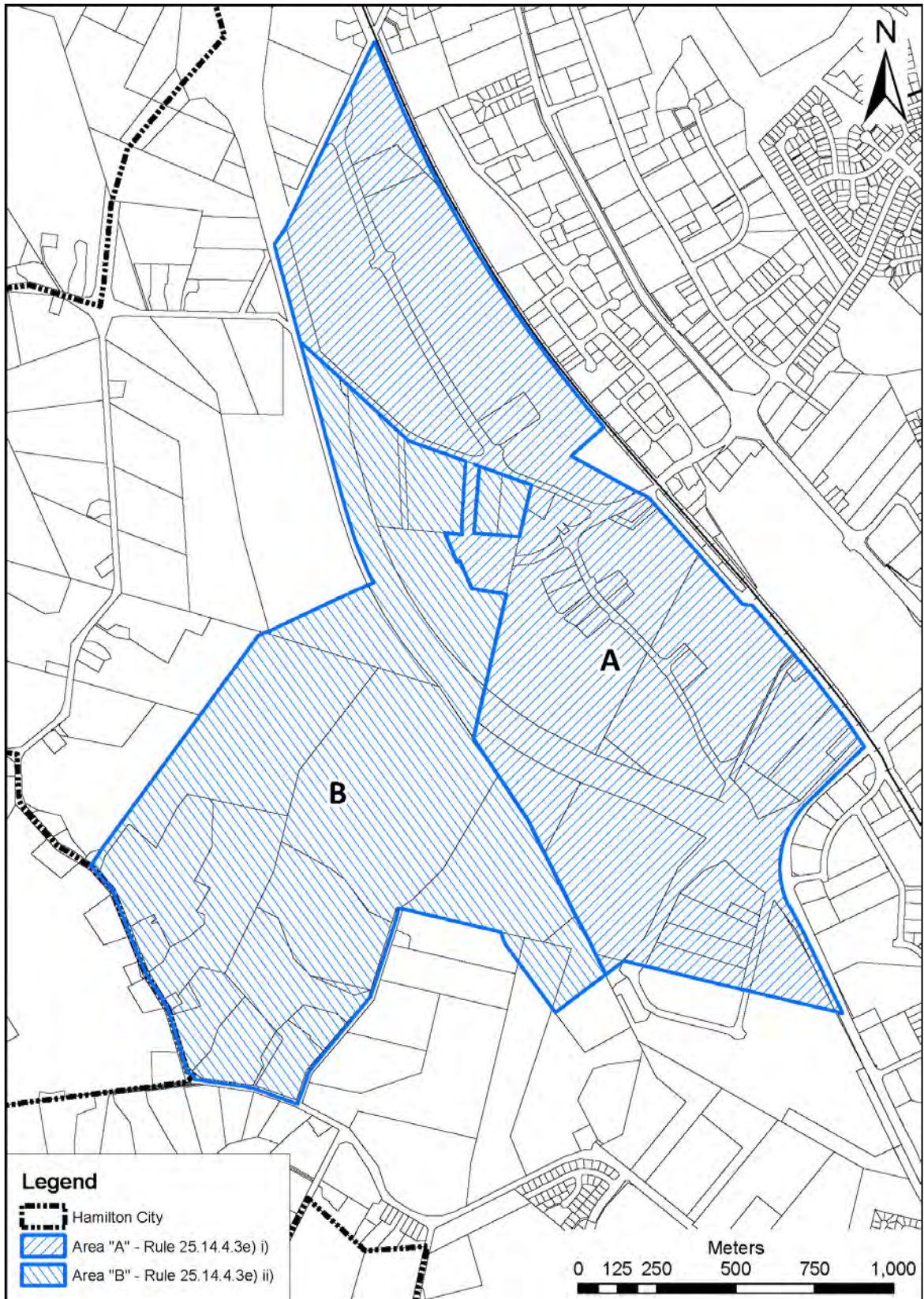

Figure 15-7b

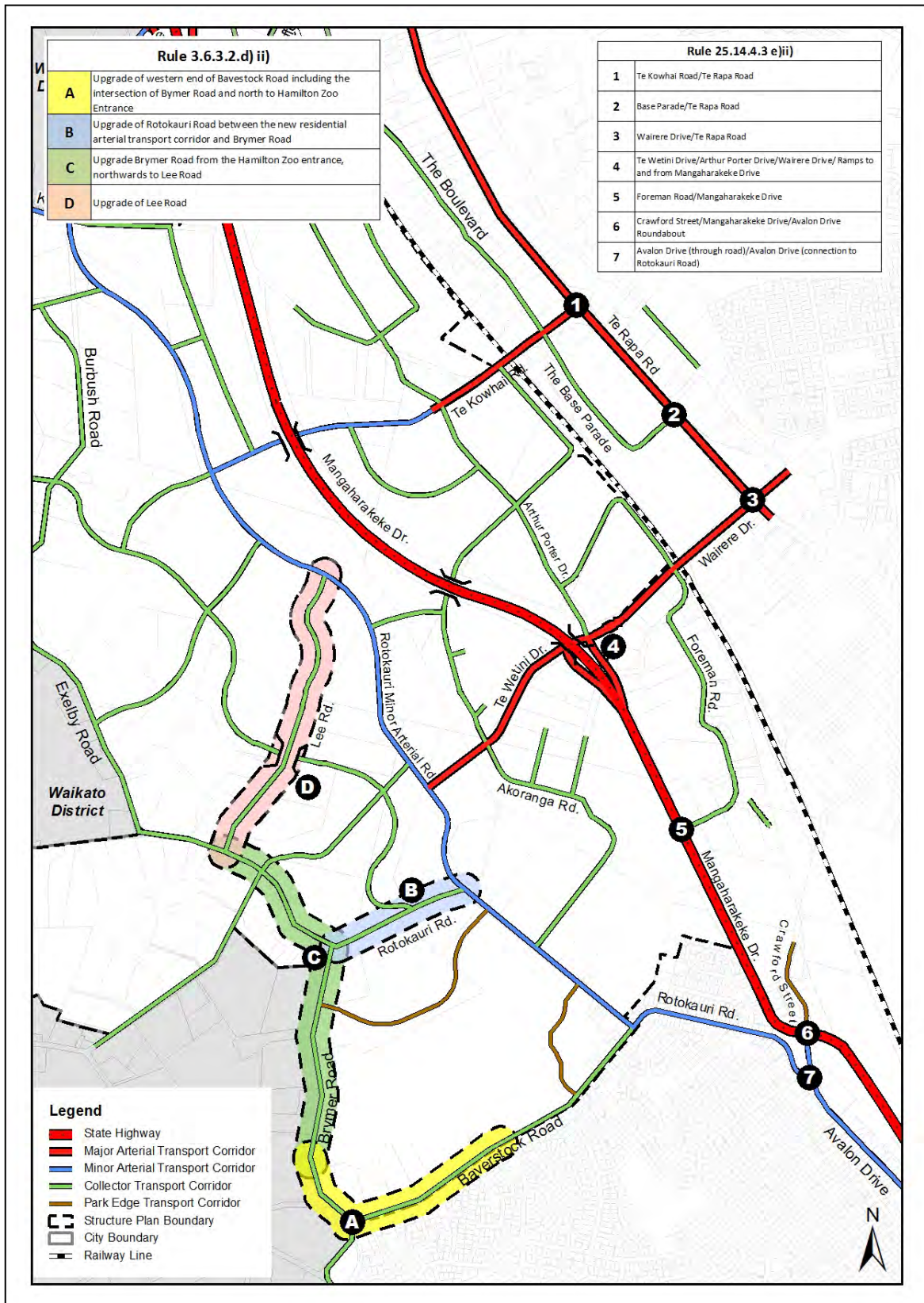

Figure 15-7c

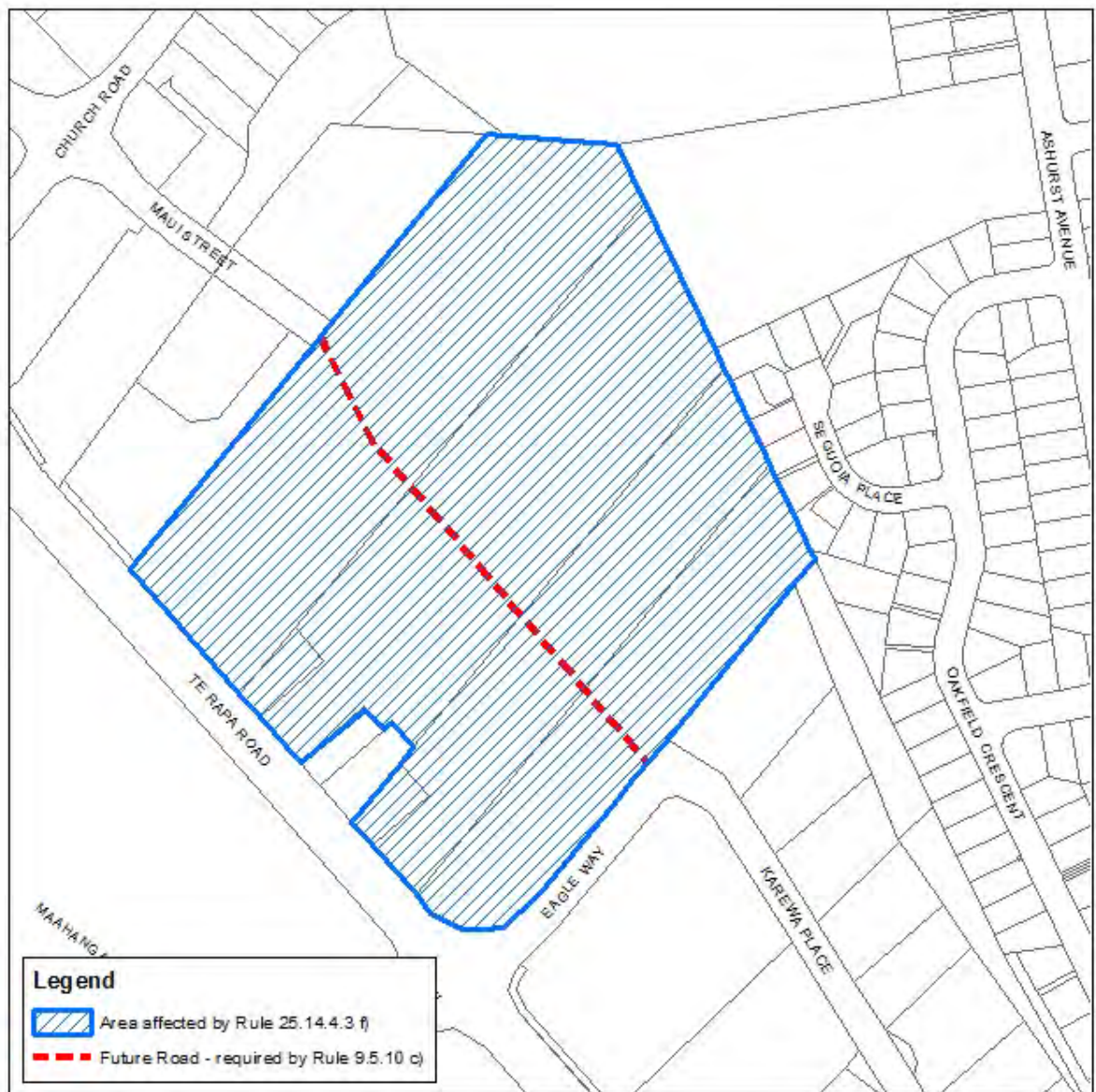

Figure 15-8: Sensitive transport network

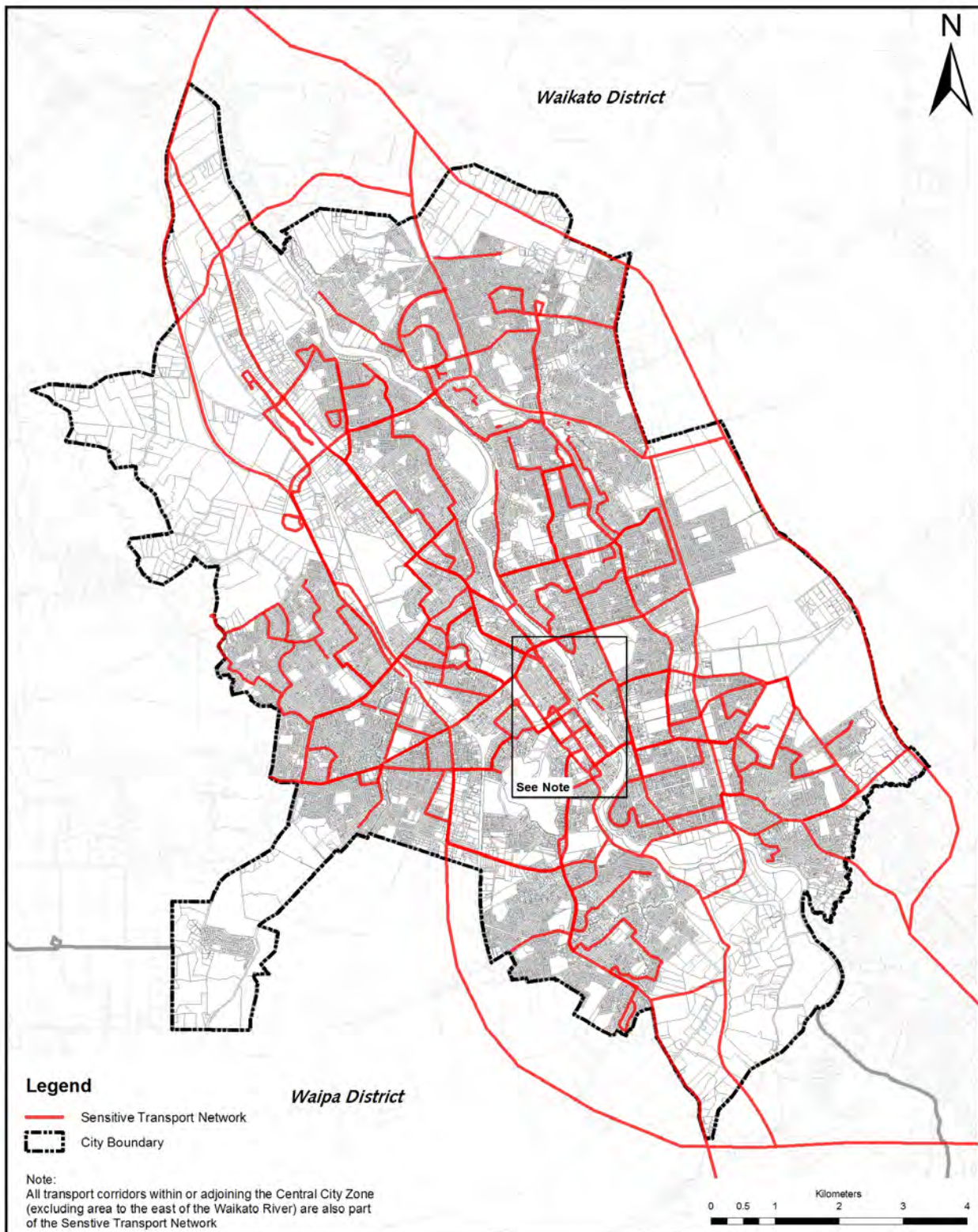

Figure 15-9: Airport protection overlay

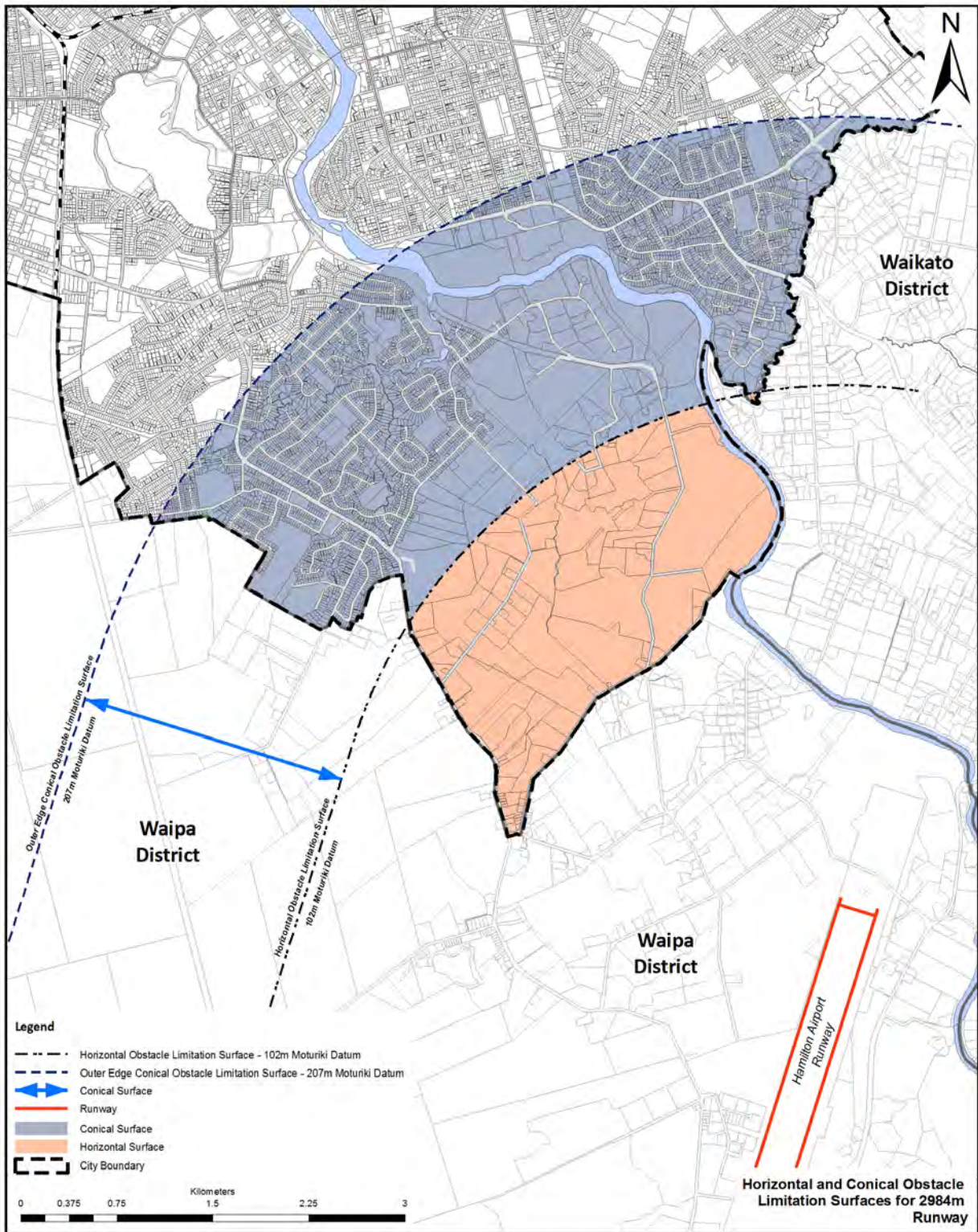

Figure 15-10: Rotokauri North – Transport Upgrades

[figure to be inserted based on final transport outcomes]