

SIEMENS

SINUMERIK

SINUMERIK 840D sl / 828D Milling

Operating Manual

Valid for:

Controller
SINUMERIK 840D sl / 840DE sl / 828D

Software version
CNC software for 840D sl / 840DE sl 4.5 SP2
SINUMERIK Operate for PCU/PC 4.5 SP2

03/2013



6FC5398-7CP40-3BA1

Preface	
Introduction	1
Setting up the machine	2
Execution in manual mode	3
Machining the workpiece	4
Simulating machining	5
Generating a G code program	6
Creating a ShopMill program	7
Programming technological functions (cycles)	8
Multi-channel view (only 840D sl)	9
Collision avoidance (only 840D sl)	10
Tool management	11
Managing programs	12
Alarm, error, and system messages	13
Working with Manual Machine	14
Teaching in a program	15
HT 8	16
Ctrl-Energy	17
Easy Message (828D only)	18
Easy Extend (828D only)	19
Service Planner (828D only)	20
Ladder Viewer and Ladder add-on (828D only)	21
Appendix	A

Legal information

Warning notice system

This manual contains notices you have to observe in order to ensure your personal safety, as well as to prevent damage to property. The notices referring to your personal safety are highlighted in the manual by a safety alert symbol, notices referring only to property damage have no safety alert symbol. These notices shown below are graded according to the degree of danger.

 DANGER
indicates that death or severe personal injury will result if proper precautions are not taken.
 WARNING
indicates that death or severe personal injury may result if proper precautions are not taken.
 CAUTION
indicates that minor personal injury can result if proper precautions are not taken.
NOTICE
indicates that property damage can result if proper precautions are not taken.

If more than one degree of danger is present, the warning notice representing the highest degree of danger will be used. A notice warning of injury to persons with a safety alert symbol may also include a warning relating to property damage.

Qualified Personnel

The product/system described in this documentation may be operated only by **personnel qualified** for the specific task in accordance with the relevant documentation, in particular its warning notices and safety instructions. Qualified personnel are those who, based on their training and experience, are capable of identifying risks and avoiding potential hazards when working with these products/systems.

Proper use of Siemens products

Note the following:

 WARNING
Siemens products may only be used for the applications described in the catalog and in the relevant technical documentation. If products and components from other manufacturers are used, these must be recommended or approved by Siemens. Proper transport, storage, installation, assembly, commissioning, operation and maintenance are required to ensure that the products operate safely and without any problems. The permissible ambient conditions must be complied with. The information in the relevant documentation must be observed.

Trademarks

All names identified by ® are registered trademarks of Siemens AG. The remaining trademarks in this publication may be trademarks whose use by third parties for their own purposes could violate the rights of the owner.

Disclaimer of Liability

We have reviewed the contents of this publication to ensure consistency with the hardware and software described. Since variance cannot be precluded entirely, we cannot guarantee full consistency. However, the information in this publication is reviewed regularly and any necessary corrections are included in subsequent editions.

Preface

SINUMERIK documentation

The SINUMERIK documentation is organized in the following categories:

- General documentation
- User documentation
- Manufacturer/service documentation

Additional information

You can find information on the following topics at www.siemens.com/motioncontrol/docu:

- Ordering documentation/overview of documentation
- Additional links to download documents
- Using documentation online (find and search in manuals/information)

Please send any questions about the technical documentation (e.g. suggestions for improvement, corrections) to the following address:

docu.motioncontrol@siemens.com

My Documentation Manager (MDM)

Under the following link you will find information to individually compile OEM-specific machine documentation based on the Siemens content:

www.siemens.com/mdm

Training

For information about the range of training courses, refer under:

- www.siemens.com/sitrain
SITRAIN - Siemens training for products, systems and solutions in automation technology
- www.siemens.com/sinustrain
SinuTrain - training software for SINUMERIK

FAQs

You can find Frequently Asked Questions in the Service&Support pages under Product Support. <http://support.automation.siemens.com>

SINUMERIK

You can find information on SINUMERIK under the following link:

www.siemens.com/sinumerik

Target group

This documentation is intended for users of milling machines running the SINUMERIK Operate software.

Benefits

The operating manual helps users familiarize themselves with the control elements and commands. Guided by the manual, users are capable of responding to problems and taking corrective action.

Standard scope

This documentation describes the functionality of the standard scope. Extensions or changes made by the machine manufacturer are documented by the machine manufacturer.

Other functions not described in this documentation might be executable in the control. However, no claim can be made regarding the availability of these functions when the equipment is first supplied or in the event of servicing.

Furthermore, for the sake of clarity, this documentation does not contain all detailed information about all types of the product and cannot cover every conceivable case of installation, operation or maintenance.

Terms

The meanings of some basic terms used in this documentation are given below.

Program

A program is a sequence of instructions to the CNC which combine to produce a specific workpiece on the machine.

Contour

The term contour refers generally to the outline of a workpiece. More specifically, it refers to the section of the program that defines the outline of a workpiece comprising individual elements.

Cycle

A cycle, e.g. milling a rectangular pocket, is a subprogram defined in SINUMERIK Operate for executing a frequently repeated machining operation.

Technical Support

You will find telephone numbers for other countries for technical support in the Internet under <http://www.siemens.com/automation/service&support>

Table of contents

	Preface	3
1	Introduction.....	19
1.1	Product overview	19
1.2	Operator panel fronts	20
1.2.1	Overview	20
1.2.2	Keys of the operator panel.....	21
1.3	Machine control panels	31
1.3.1	Overview	31
1.3.2	Controls on the machine control panel	31
1.4	User interface.....	34
1.4.1	Screen layout	34
1.4.2	Status display.....	35
1.4.3	Actual value window	38
1.4.4	T,F,S window	40
1.4.5	Current block display	42
1.4.6	Operation via softkeys and buttons	43
1.4.7	Entering or selecting parameters	44
1.4.8	Pocket calculator.....	47
1.4.9	Context menu.....	48
1.4.10	Touch operation	49
1.4.11	Changing the user interface language.....	49
1.4.12	Entering Asian characters.....	50
1.4.13	Protection levels.....	52
1.4.14	Online help in SINUMERIK Operate.....	54
2	Setting up the machine	59
2.1	Switching on and switching off.....	59
2.2	Approaching a reference point.....	60
2.2.1	Referencing axes	60
2.2.2	User agreement	61
2.3	Operating modes	63
2.3.1	General	63
2.3.2	Modes groups and channels.....	65
2.3.3	Channel switchover.....	65
2.4	Settings for the machine	67
2.4.1	Switching over the coordinate system (MCS/WCS)	67
2.4.2	Switching the unit of measurement.....	68
2.4.3	Setting the zero offset.....	69
2.5	Measuring the tool	71
2.5.1	Measuring a tool manually	71
2.5.2	Measuring the tool length with the workpiece as reference point.....	72
2.5.3	Measuring radius or diameter	73

2.5.4	Fixed point calibration	74
2.5.5	Measuring a tool with an electrical tool probe.....	75
2.5.6	Calibrating the electrical tool probe.....	77
2.6	Measuring the workpiece zero	78
2.6.1	Overview	78
2.6.2	Sequence of operations	83
2.6.3	Examples with manual swivel	84
2.6.4	Calibrating the electronic workpiece probe	85
2.6.5	Setting the edge	87
2.6.6	Edge measurement.....	89
2.6.7	Measuring a corner	91
2.6.8	Measuring a pocket and hole	95
2.6.9	Measuring a spigot.....	101
2.6.10	Aligning the plane.....	108
2.6.11	Defining the measurement function selection.....	110
2.6.12	Corrections after measurement of the zero point	111
2.7	Zero offsets	113
2.7.1	Display active zero offset	114
2.7.2	Displaying the zero offset "overview".....	115
2.7.3	Displaying and editing base zero offset	116
2.7.4	Displaying and editing settable zero offset	117
2.7.5	Displaying and editing details of the zero offsets.....	118
2.7.6	Deleting a zero offset	119
2.7.7	Measuring the workpiece zero	120
2.8	Monitoring axis and spindle data	121
2.8.1	Specify working area limitations.....	121
2.8.2	Editing spindle data	122
2.9	Displaying setting data lists.....	123
2.10	Handwheel assignment.....	123
2.11	MDA	126
2.11.1	Loading an MDA program from the Program Manager	126
2.11.2	Saving an MDA program.....	127
2.11.3	Executing an MDA program.....	128
2.11.4	Deleting an MDA program.....	128
3	Execution in manual mode.....	129
3.1	General.....	129
3.2	Selecting a tool and spindle	129
3.2.1	T, S, M windows.....	129
3.2.2	Selecting a tool.....	131
3.2.3	Starting and stopping a spindle manually	132
3.2.4	Position spindle	133
3.3	Traversing axes.....	134
3.3.1	Traverse axes by a defined increment.....	134
3.3.2	Traversing axes by a variable increment	135
3.4	Positioning axes	136
3.5	Swiveling	137

3.6	Manual retraction	142
3.7	Simple face milling of the workpiece.....	144
3.8	Default settings for manual mode	147
4	Machining the workpiece	149
4.1	Starting and stopping machining.....	149
4.2	Selecting a program.....	151
4.3	Testing a program.....	152
4.4	Displaying the current program block	153
4.4.1	Current block display	153
4.4.2	Displaying a basic block.....	154
4.4.3	Display program level	155
4.5	Correcting a program	156
4.6	Repositioning axes.....	157
4.7	Starting machining at a specific point	158
4.7.1	Use block search	158
4.7.2	Continuing program from search target	160
4.7.3	Simple search target definition.....	161
4.7.4	Defining an interruption point as search target.....	162
4.7.5	Entering the search target via search pointer.....	163
4.7.6	Parameters for block search in the search pointer	164
4.7.7	Block search mode	165
4.8	Controlling the program run	167
4.8.1	Program control.....	167
4.8.2	Skip blocks.....	168
4.9	Overstore	170
4.10	Editing a program.....	172
4.10.1	Searching in programs.....	173
4.10.2	Replacing program text.....	174
4.10.3	Copying/pasting/deleting a program block.....	176
4.10.4	Renumber program.....	177
4.10.5	Creating a program block.....	178
4.10.6	Opening additional programs.....	179
4.10.7	Editor settings	181
4.11	Display and edit user variables	183
4.11.1	Overview	183
4.11.2	R parameters	184
4.11.3	Displaying global user data (GUD)	185
4.11.4	Displaying channel GUDs	186
4.11.5	Displaying local user data (LUD)	187
4.11.6	Displaying program user data (PUD).....	188
4.11.7	Searching for user variables	189
4.12	Displaying G Functions and Auxiliary Functions.....	191
4.12.1	Selected G functions.....	191
4.12.2	All G functions.....	193
4.12.3	G functions for mold making	194

4.12.4	Auxiliary functions	196
4.13	Mold making view.....	198
4.13.1	Starting the mold making view	201
4.13.2	Specifically jump to the program block	202
4.13.3	Searching for program blocks	202
4.13.4	Changing the view.....	203
4.13.4.1	Enlarging or reducing the graphical representation	203
4.13.4.2	Modifying the viewport	204
4.14	Displaying the program runtime and counting workpieces	205
4.15	Setting for automatic mode	207
5	Simulating machining.....	209
5.1	Overview	209
5.2	Simulation before machining of the workpiece	216
5.3	Simultaneous recording before machining of the workpiece	217
5.4	Simultaneous recording during machining of the workpiece	218
5.5	Different views of the workpiece	219
5.5.1	Plan view.....	219
5.5.2	3D view.....	219
5.5.3	Side view.....	220
5.6	Editing the simulation display.....	221
5.6.1	Blank display.....	221
5.6.2	Showing and hiding the tool path.....	221
5.7	Program control during the simulation	222
5.7.1	Changing the feedrate.....	222
5.7.2	Simulating the program block by block	223
5.8	Changing and adapting a simulation graphic.....	224
5.8.1	Enlarging or reducing the graphical representation	224
5.8.2	Panning a graphical representation	225
5.8.3	Rotating the graphical representation	225
5.8.4	Modifying the viewport	226
5.8.5	Defining cutting planes.....	227
5.9	Displaying simulation alarms.....	228
6	Generating a G code program	229
6.1	Graphical programming.....	229
6.2	Program views	230
6.3	Program structure	233
6.4	Fundamentals	234
6.4.1	Machining planes	234
6.4.2	Current planes in cycles and input screens	235
6.4.3	Programming a tool (T)	235
6.5	Generating a G code program	237
6.6	Blank input	238

6.7	Machining plane, milling direction, retraction plane, safe clearance and feedrate (PL, RP, SC, F).....	240
6.8	Selection of the cycles via softkey	241
6.9	Calling technology functions	245
6.9.1	Hiding cycle parameters	245
6.9.2	Setting data for cycles.....	246
6.9.3	Checking cycle parameters.....	246
6.9.4	Programming variables	246
6.9.5	Changing a cycle call	247
6.9.6	Compatibility for cycle support.....	247
6.9.7	Additional functions in the input screens	248
6.10	Measuring cycle support.....	248
7	Creating a ShopMill program	249
7.1	Program views	250
7.2	Program structure	254
7.3	Fundamentals	255
7.3.1	Machining planes	255
7.3.2	Polar coordinates	256
7.3.3	Absolute and incremental dimensions	256
7.4	Creating a ShopMill program	258
7.5	Program header	259
7.6	Generating program blocks.....	261
7.7	Tool, offset value, feed and spindle speed (T, D, F, S, V).....	262
7.8	Defining machine functions.....	264
7.9	Call work offsets.....	266
7.10	Repeating program blocks	266
7.11	Specifying the number of workpieces	268
7.12	Changing program blocks	269
7.13	Changing program settings.....	270
7.13.1	Parameters.....	271
7.14	Selection of the cycles via softkey	273
7.15	Calling technology functions	277
7.15.1	Additional functions in the input screens	277
7.15.2	Programming variables	278
7.15.3	Checking input parameters.....	278
7.15.4	Setting data for technological functions	279
7.15.5	Changing a cycle call	279
7.15.6	Compatibility for cycle support.....	280
7.16	Measuring cycle support.....	280
7.17	Example, standard machining.....	281
7.17.1	Workpiece drawing	282
7.17.2	Programming.....	282

7.17.3	Results/simulation test	294
7.17.4	G code machining program.....	296
8	Programming technological functions (cycles).....	299
8.1	Drilling	299
8.1.1	General.....	299
8.1.2	Centering (CYCLE81)	300
8.1.2.1	Function.....	300
8.1.3	Drilling (CYCLE82).....	302
8.1.3.1	Function.....	302
8.1.4	Reaming (CYCLE85)	304
8.1.4.1	Function.....	304
8.1.5	Deep-hole drilling (CYCLE83).....	305
8.1.5.1	Function.....	305
8.1.6	Boring (CYCLE86)	309
8.1.6.1	Function.....	309
8.1.7	Tapping (CYCLE84, 840).....	311
8.1.7.1	Function.....	311
8.1.8	Drill and thread milling (CYCLE78)	317
8.1.8.1	Function.....	317
8.1.9	Positioning and position patterns	321
8.1.10	Arbitrary positions (CYCLE802).....	323
8.1.11	Position pattern line (HOLES1), grid or frame (CYCLE801).....	327
8.1.12	Circle position pattern (HOLES2).....	329
8.1.13	Displaying and hiding positions.....	331
8.1.14	Repeating positions.....	332
8.2	Milling	334
8.2.1	Face milling (CYCLE61).....	334
8.2.1.1	Function.....	334
8.2.2	Rectangular pocket (POCKET3).....	337
8.2.3	Circular pocket (POCKET4)	341
8.2.4	Rectangular spigot (CYCLE76).....	347
8.2.5	Circular spigot (CYCLE77).....	350
8.2.6	Multi-edge (CYCLE79).....	353
8.2.6.1	Parameter.....	354
8.2.7	Longitudinal groove (SLOT1).....	355
8.2.8	Circumferential groove (SLOT2)	360
8.2.9	Open groove (CYCLE899).....	363
8.2.10	Long hole (LONGHOLE) - only for G code programs	371
8.2.11	Thread milling (CYCLE70)	373
8.2.12	Engraving (CYCLE60).....	377
8.3	Contour milling	383
8.3.1	General.....	383
8.3.2	Representation of the contour.....	383
8.3.3	Creating a new contour	385
8.3.4	Creating contour elements	387
8.3.5	Changing the contour	392
8.3.6	Contour call (CYCLE62) - only for G code program	393
8.3.7	Path milling (CYCLE72)	394
8.3.8	Contour pocket/contour spigot (CYCLE63/64).....	398
8.3.9	Predrilling contour pocket (CYCLE64)	400

8.3.10	Milling contour pocket (CYCLE63).....	403
8.3.11	Residual material contour pocket (CYCLE63).....	406
8.3.12	Milling contour spigot (CYCLE63).....	408
8.3.13	Residual material contour spigot (CYCLE63).....	410
8.4	Turning - only for G code programs.....	412
8.4.1	General.....	412
8.4.2	Stock removal (CYCLE951).....	412
8.4.2.1	Function.....	412
8.4.3	Groove (CYCLE930).....	417
8.4.3.1	Function.....	417
8.4.4	Undercut form E and F (CYCLE940).....	422
8.4.4.1	Function.....	422
8.4.5	Thread undercut (CYCLE940).....	426
8.4.5.1	Function.....	426
8.4.6	Thread turning (CYCLE99).....	429
8.4.6.1	Function.....	429
8.4.7	Thread chain (CYCLE98).....	438
8.4.7.1	Function.....	438
8.4.8	Cut-off (CYCLE92).....	441
8.5	Contour turning- only for G code programs.....	443
8.5.1	General information.....	443
8.5.2	Representation of the contour.....	444
8.5.3	Creating a new contour.....	445
8.5.4	Creating contour elements.....	447
8.5.5	Changing the contour.....	453
8.5.6	Contour call (CYCLE62).....	454
8.5.6.1	Function.....	454
8.5.7	Stock removal (CYCLE952).....	455
8.5.7.1	Function.....	455
8.5.8	Stock removal residual (CYCLE952).....	461
8.5.8.1	Function.....	461
8.5.9	Grooving (CYCLE952).....	464
8.5.9.1	Function.....	464
8.5.10	Grooving residual material (CYCLE952).....	467
8.5.11	Plunge turning (CYCLE952).....	469
8.5.12	Plunge turning residual material (CYCLE952).....	472
8.6	Further cycles and functions.....	475
8.6.1	Swivel plane/tool (CYCLE800).....	475
8.6.2	Swiveling tool (CYCLE800).....	485
8.6.2.1	Swiveling tool/preloading milling tools - only for G code program (CYCLE800).....	485
8.6.2.2	Swiveling aligning tool - only for G code program (CYCLE800).....	487
8.6.3	High-speed settings (CYCLE832).....	488
8.6.4	Subroutines.....	491
8.7	Additional cycles and functions in ShopMill.....	493
8.7.1	Transformations.....	493
8.7.2	Translation.....	494
8.7.3	Rotation.....	495
8.7.4	Scaling.....	496
8.7.5	Mirroring.....	497
8.7.6	Cylinder surface transformation.....	498

8.7.6.1	General programming	499
8.7.7	Straight or circular machining.....	501
8.7.8	Programming a straight line	503
8.7.9	Programming a circle with known center point	504
8.7.10	Programming a circle with known radius	505
8.7.11	Helix	506
8.7.12	Polar coordinates	507
8.7.13	Straight polar	508
8.7.14	Circle polar	509
8.7.15	Obstacle	510
9	Multi-channel view (only 840D sl)	511
9.1	Multi-channel view.....	511
9.2	Multi-channel view in the "Machine" operating area	511
9.3	Multi-channel view for large operator panels	514
9.4	Setting the multi-channel view	516
10	Collision avoidance (only 840D sl).....	519
10.1	Collision monitoring in the machine operator area:	519
10.2	Switching the collision avoidance on and off	520
11	Tool management.....	523
11.1	Lists for the tool management.....	523
11.2	Magazine management.....	524
11.3	Tool types.....	525
11.4	Tool dimensioning	527
11.5	Tool list.....	534
11.5.1	Additional data	537
11.5.2	Creating a new tool	538
11.5.3	Measuring the tool.....	540
11.5.4	Managing several cutting edges	540
11.5.5	Delete tool	541
11.5.6	Loading and unloading tools	542
11.5.7	Selecting a magazine.....	544
11.5.8	Code carrier connection (only 840D sl).....	545
11.6	Tool wear.....	548
11.6.1	Reactivating a tool.....	551
11.7	Tool data OEM	552
11.8	Magazine.....	553
11.8.1	Positioning a magazine	555
11.8.2	Relocating a tool	555
11.8.3	Unload all tools.....	557
11.9	Graphic display	558
11.10	Sorting tool management lists.....	560
11.11	Filtering the tool management lists	561

11.12	Specific search in the tool management lists.....	563
11.13	Displaying tool details	564
11.14	Displaying all tool details.....	566
11.15	Changing a tool type	567
11.16	Settings for tool lists.....	568
12	Managing programs.....	571
12.1	Overview	571
12.1.1	NC memory.....	574
12.1.2	Local drive.....	575
12.1.3	USB drives	576
12.1.4	FTP drive.....	577
12.2	Opening and closing the program.....	578
12.3	Executing a program.....	580
12.4	Creating a directory / program / job list / program list.....	581
12.4.1	Creating a new directory	581
12.4.2	Creating a new workpiece.....	582
12.4.3	Creating a new G code program.....	583
12.4.4	Creating a new ShopMill program.....	584
12.4.5	Storing any new file.....	585
12.4.6	Creating a job list	586
12.4.7	Creating a program list.....	587
12.5	Creating templates.....	589
12.6	Searching directories and files.....	590
12.7	Displaying the program in the Preview.	591
12.8	Selecting several directories/programs.....	592
12.9	Copying and pasting a directory/program.....	594
12.10	Deleting a program/directory.....	596
12.10.1	Deleting a program/directory.....	596
12.11	Changing file and directory properties	597
12.12	Set up drives	599
12.12.1	Overview	599
12.12.2	Setting up drives	599
12.13	Viewing PDF documents.....	603
12.14	EXTCALL	604
12.15	Backing up data	607
12.15.1	Generating an archive in the Program Manager.....	607
12.15.2	Generating an archive via the system data	608
12.15.3	Reading in an archive in the Program Manager	610
12.15.4	Read in archive from system data	612
12.16	Setup data.....	613
12.16.1	Backing up setup data	613
12.16.2	Reading-in set-up data.....	616

12.17	RS-232-C	618
12.17.1	Reading-in and reading-out archives	618
12.17.2	Setting V24 in the program manager	620
12.18	Multiple clamping	622
12.18.1	Multiple clamping	622
12.18.2	Program header setting, "Clamping"	623
12.18.3	Creating a multiple clamping program	624
13	Alarm, error, and system messages	627
13.1	Displaying alarms	627
13.2	Displaying an alarm log	629
13.3	Displaying messages	630
13.4	Sorting, alarms, faults and messages	631
13.5	PLC and NC variables	632
13.5.1	Displaying and editing PLC and NC variables	632
13.5.2	Saving and loading screen forms	636
13.5.3	Load symbols	637
13.6	Version	638
13.6.1	Displaying version data	638
13.6.2	Save information	639
13.7	Logbook	640
13.7.1	Displaying and editing the logbook	641
13.7.2	Making a logbook entry	642
13.8	Creating screenshots	643
13.9	Remote diagnostics	644
13.9.1	Setting remote access	644
13.9.2	Permit modem	646
13.9.3	Request remote diagnostics	647
13.9.4	Exit remote diagnostics	648
14	Working with Manual Machine	649
14.1	Measuring the tool	650
14.2	Measuring the workpiece zero	650
14.3	Setting the zero offset	651
14.4	Set limit stop	652
14.5	Simple workpiece machining	653
14.5.1	Traversing axes	653
14.5.2	Angular milling	654
14.5.3	Straight and circular machining	655
14.5.3.1	Straight milling	655
14.5.3.2	Circular milling	657
14.6	More complex machining	658
14.6.1	Drilling with Manual Machine	660
14.6.2	Milling with Manual Machine	661
14.6.3	Contour milling with manual machine	662

14.7	Simulation and simultaneous recording.....	663
15	Teaching in a program.....	665
15.1	Overview	665
15.2	General sequence.....	665
15.3	Inserting a block.....	666
15.3.1	Input parameters for teach-in blocks	667
15.4	Teach-in via window	669
15.4.1	General	669
15.4.2	Teach in rapid traverse G0	670
15.4.3	Teach in straight G1.....	670
15.4.4	Teaching in circle intermediate and circle end point CIP.....	671
15.4.5	Teach-in A spline	671
15.5	Editing a block.....	673
15.6	Selecting a block.....	674
15.7	Deleting a block	675
16	HT 8.....	677
16.1	HT 8 overview	677
16.2	Traversing keys.....	680
16.3	Machine control panel menu.....	681
16.4	Virtual keyboard	682
16.5	Calibrating the touch panel	684
17	Ctrl-Energy	685
17.1	Overview	685
17.2	Displaying energy consumption	686
17.3	Measuring and saving the energy consumption	687
17.4	Long-term measurement of the energy consumption	688
17.5	Displaying measured curves.....	689
17.6	Using the energy-saving profile	690
18	Easy Message (828D only).....	693
18.1	Overview	693
18.2	Activating Easy Message.....	694
18.3	Creating/editing a user profile	695
18.4	Setting-up events	697
18.5	Logging an active user on and off.....	699
18.6	Displaying SMS logs	700
18.7	Making settings for Easy Message	701

19	Easy Extend (828D only)	703
19.1	Overview	703
19.2	Enabling a device	704
19.3	Activating and deactivating a device	704
19.4	Commissioning Easy Extend	705
20	Service Planner (828D only)	707
20.1	Performing and monitoring maintenance tasks	707
20.2	Set maintenance tasks	709
21	Ladder Viewer and Ladder add-on (828D only)	711
21.1	PLC diagnostics	711
21.2	Structure of the user interface	711
21.3	Control options	712
21.4	Displaying PLC properties	714
21.5	Displaying and editing NC/PLC variables	715
21.6	Displaying and editing PLC signals	716
21.7	Displaying information on the program blocks	717
21.8	Loading modified PLC user program	719
21.9	Editing the local variable table	720
21.10	Creating a new block	722
21.11	Editing block properties subsequently	723
21.12	Inserting and editing networks	724
21.13	Editing network properties	726
21.14	Displaying and editing symbol tables	727
21.15	Inserting/deleting a symbol table	728
21.16	Searching for operands	729
21.17	Displaying the network symbol information table	730
21.18	Displaying/canceling the access protection	731
21.19	Displaying cross references	731
A	Appendix	733
A.1	840D sl documentation overview	733
	Index	735

Introduction

1.1 Product overview

The SINUMERIK controller is a CNC (Computerized Numerical Controller) for machine tools.

You can use the CNC to implement the following basic functions in conjunction with a machine tool:

- Creation and adaptation of part programs
- Execution of part programs
- Manual control
- Access to internal and external data media
- Editing of data for programs
- Management of tools, zero points and further user data required in programs
- Diagnostics of controller and machine

Operating areas

The basic functions are grouped in the following operating areas in the controller:

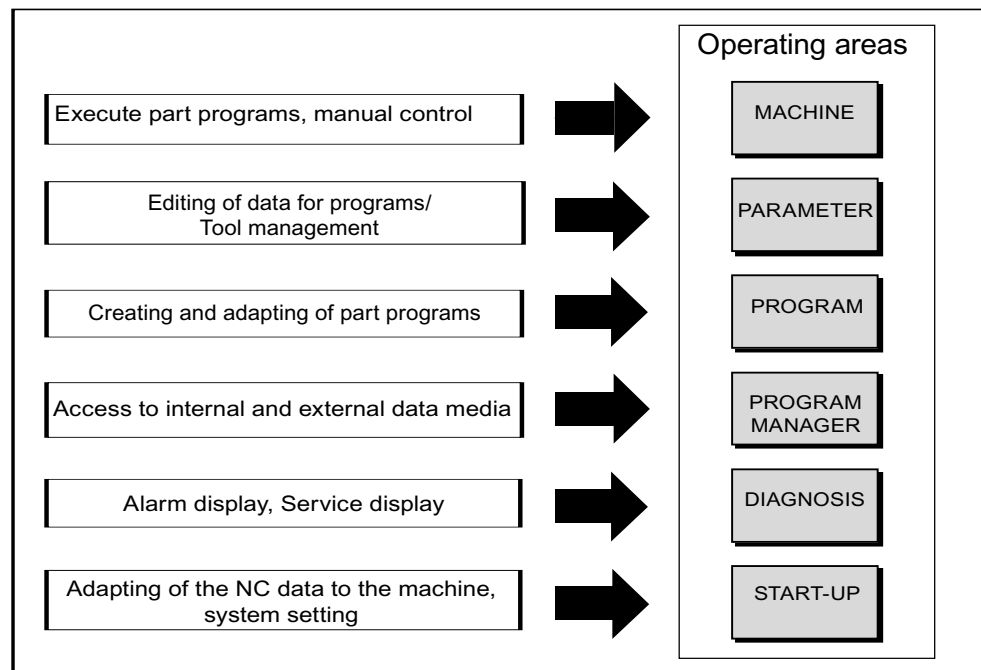

1.2 Operator panel fronts

1.2.1 Overview

Introduction

The display (screen) and operation (e.g. hardkeys and softkeys) of the SINUMERIK Operate user interface use the operator panel front.

In this example, the OP 010 operator panel front is used to illustrate the components that are available for operating the controller and machine tool.

Operator controls and indicators

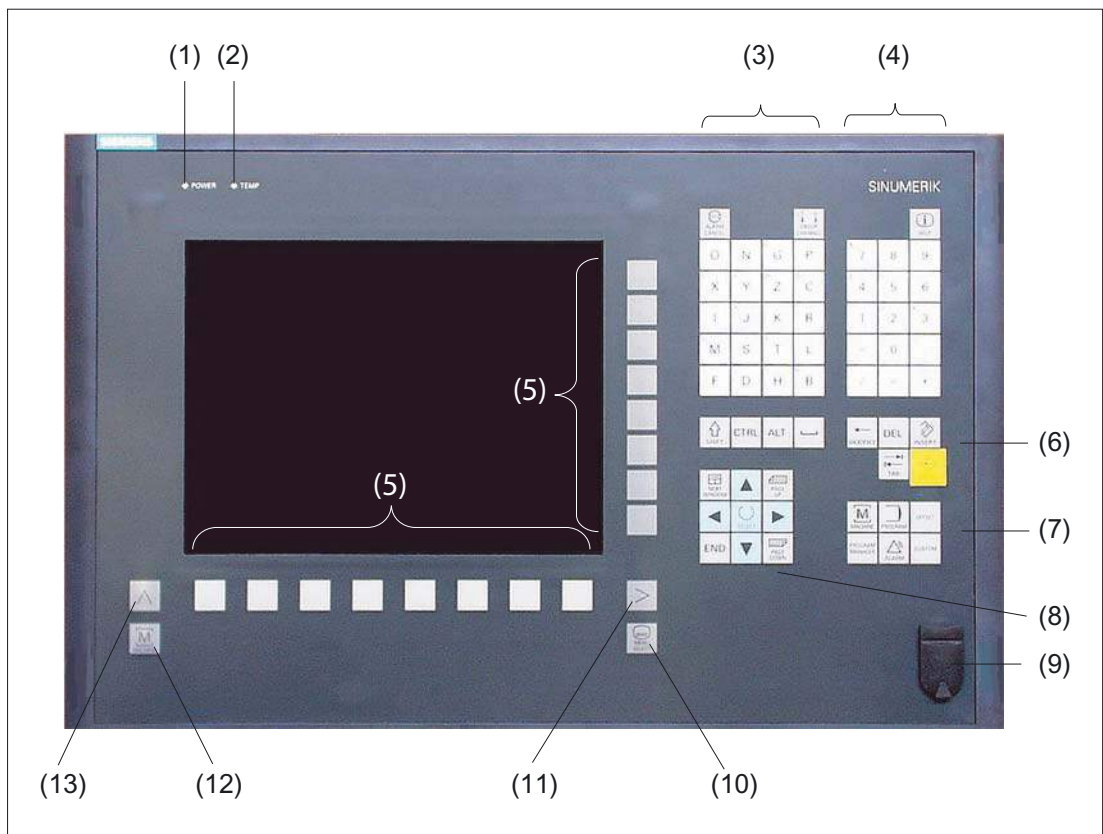

- 1 Status LED: POWER
- 2 Status LED: TEMP
(illuminated LEDs indicate increased wear)
- 3 Alphabetic key group
- 4 Numerical key group
- 5 Softkeys

- 6 Control key group
- 7 Hotkey group
- 8 Cursor key group
- 9 USB interface
- 10 Menu select key
- 11 Menu forward button
- 12 Machine area button
- 13 Menu back key

Figure 1-1 View of OP 010 operator panel front

References



A more precise description as well as a view of the other operator panel fronts that can be used may be found in the following reference:

Operator Components and Networking Manual; SINUMERIK 840D sl/840Di sl

1.2.2 Keys of the operator panel

The following keys and key combinations are available for operation of the controller and the machine tool.

Keys and key combinations

Key	Function
	<ALARM CANCEL> Cancels alarms and messages that are marked with this symbol.
	<CHANNEL> Advances for several channels.
	<HELP> Calls the context-sensitive online help for the selected window.



<NEXT WINDOW> *

- Toggles between the windows.
- For a multi-channel view or for a multi-channel functionality, switches within a channel gap between the upper and lower window.
- Selects the first entry in selection lists and in selection fields.
- Moves the cursor to the beginning of a text.

* on USB keyboards use the <Home> or <Pos 1> key

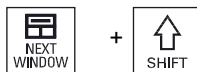

<NEXT WINDOW> + <SHIFT>

- Selects the first entry in selection lists and in selection fields.
- Moves the cursor to the beginning of a text.
- Selects a contiguous selection from the current cursor position up to the target position.
- Selects a contiguous selection from the current cursor position up to the beginning of a program block.

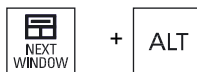

<NEXT WINDOW> + <ALT>

- Moves the cursor to the first object.
- Moves the cursor in the first column of a table row.
- Moves the cursor to the beginning of a program block.

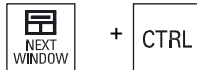

<NEXT WINDOW> + <CTRL>

- Moves the cursor to the beginning of a program.
- Moves the cursor in the first row of the current column.



<NEXT WINDOW> + <CTRL> + <SHIFT>

- Moves the cursor to the beginning of a program.
- Moves the cursor in the first row of the current column.
- Selects a contiguous selection from the current cursor position up to the target position.
- Selects a contiguous selection from the current cursor position up to the beginning of the program.



<PAGE UP>

Scrolls upwards by one page in a window.



<PAGE UP> + <SHIFT>

In the program manager and in the program editor from the cursor position, selects directories or program blocks up to the beginning of the window.

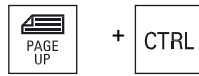
**<PAGE UP> + <CTRL>**

Positions the cursor to the topmost line of a window.

**<PAGE DOWN>**

Scrolls downwards by one page in a window.

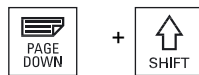
**<PAGE DOWN> + <SHIFT>**

In the program manager and in the program editor, from the cursor position, selects directories or program blocks up to the end of the window.

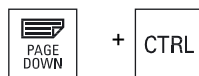
**<PAGE DOWN> + <CTRL>**

Positions the cursor to the lowest line of a window.

**<Cursor right>**

- Editing box
Opens a directory or program (e.g. cycle) in the editor.
- Navigation
Moves the cursor further to the right by one character.

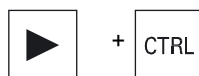
**<Cursor right> + <CTRL>**

- Editing box
Moves the cursor further to the right by one word.
- Navigation
Moves the cursor in a table to the next cell to the right.

**<Cursor left>**

- Editing box
Closes a directory or program (e.g. cycle) in the program editor. If you have made changes, then these are accepted.
- Navigation
Moves the cursor further to the left by one character.

**<Cursor left> + <CTRL>**

- Editing box
Moves the cursor further to the left by one word.
- Navigation
Moves the cursor in a table to the next cell to the left.

**<Cursor up>**

- Editing box
 - Moves the cursor into the next upper field.
- Navigation
 - Moves the cursor in a table to the next cell upwards.
 - Moves the cursor upwards in a menu screen.

**<Cursor up> + <CTRL>**

- Moves the cursor in a table to the beginning of the table.
- Moves the cursor to the beginning of a window.

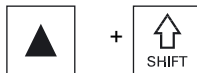
**<Cursor up> + <SHIFT>**

In the program manager and in the program editor, selects a contiguous selection of directories and program blocks.

**<Cursor down>**

- Editing box
 - Moves the cursor downwards.
- Navigation
 - Moves the cursor in a table to the next cell downwards.
 - Moves the cursor in a window downwards.

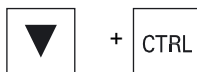
**<Cursor down> + <CTRL>**

- Navigation
 - Moves the cursor in a table to the end of the table.
 - Moves the cursor to the end of a window.
- Simulation
 - Reduces the override.

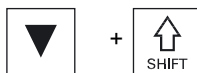
**<Cursor down> + <SHIFT>**

In the program manager and in the program editor, selects a contiguous selection of directories and program blocks.

**<SELECT>**

Switches between several specified options in selection drop-down list boxes and in selection boxes.

Activates checkboxes.

In the program editor and in the program manager, selects a program block or a program.

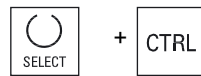

+ CTRL

<SELECT> + <CTRL>

When selecting table rows, switches between selected and not selected.

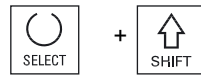

+ SHIFT

<SELECT> + <SHIFT>

Selects in selection lists and in selection fields the previous entry or the last entry.

**<END>**

Moves the cursor to the last entry field in a window, to the end of a table or a program block.

Selects the last entry in selection lists and in selection fields.

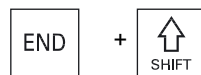

+ SHIFT

<END> + <SHIFT>

Moves the cursor to the last entry.

Selects a contiguous selection from the cursor position up to the end of a program block.

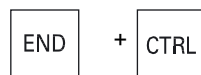

+ CTRL

<END> + <CTRL>

Moves the cursor to the last entry in the last line of the actual column or to the end of a program.



+ CTRL

**<END> + <CTRL> + <SHIFT>**

Moves the cursor to the last entry in the last line of the actual column or to the end of a program.

Selects a contiguous selection from the cursor position up to the end of a program block.

**<BACKSPACE>**

- Editing box

Deletes a character selected to the left of the cursor.

- Navigation

Deletes all of the selected characters to the left of the cursor.

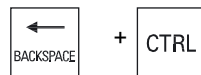

+ CTRL

<BACKSPACE> + <CTRL>

- Editing window

Deletes a word selected to the left of the cursor.

- Navigation

Deletes all of the selected characters to the left of the cursor.

**<TAB>**

- In the program editor, indents the cursor by one character.
- In the program manager, moves the cursor to the next entry to the right.

**<TAB> + <SHIFT>**

- In the program editor, indents the cursor by one character.
- In the program manager, moves the cursor to the next entry to the left.

**<TAB> + <CTRL>**

- In the program editor, indents the cursor by one character.
- In the program manager, moves the cursor to the next entry to the right.

**<TAB> + <SHIFT> + <CTRL>**

- In the program editor, indents the cursor by one character.
- In the program manager, moves the cursor to the next entry to the left.

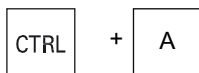
**<CTRL> + <A>**

In the actual window, selects all entries (only in the program editor and program manager).

**<CTRL> + <C>**

Copies the selected content.

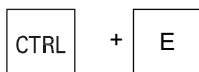
**<CTRL> + <E>**

Calls the "Ctrl Energy" function.

**<CTRL> + <F>**

Opens the search dialog in the machine data and setting data lists, when loading and saving in the MDI editor as well as in the program manager and in the system data.

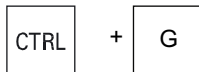



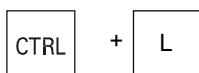















**<CTRL> + <G>**

- Switches in the program editor for ShopMill or ShopTurn programs between the work plan and the graphic view.
- Switches in the the parameter screen between the help display and the graphic view.

**<CTRL> + <L>**

Scrolls the actual user interface through all installed languages one after the other.

CTRL	+		+	L	<p><CTRL> + <SHIFT> + <L> Scrolls the actual user interface through all installed languages in the inverse sequence.</p>
CTRL	+	P	<p><CTRL> + <P> Generates a screenshot from the actual user interface and saves it as file.</p>		
CTRL	+	S	<p><CTRL> + <S> Switches the single block in or out in the simulation.</p>		
CTRL	+	V	<p><CTRL> + <V></p> <ul style="list-style-type: none"> • Pastes text from the clipboard at the actual cursor position. • Pastes text from the clipboard at the position of a selected text. 		
CTRL	+	X	<p><CTRL> + <X> Cuts out the selected text. The text is located in the clipboard.</p>		
CTRL	+	Y	<p><CTRL> + <Y> Reactivates changes that were undone (only in the program editor).</p>		
CTRL	+	Z	<p><CTRL> + <Z> Undoes the last action (only in the program editor).</p>		
CTRL	+	ALT	+	C	<p><CTRL> + <ALT> + <C> Creates a complete standard archive (.ARC) on an external data carrier (USB-FlashDrive) (for 840D sl / 828D).</p> <p>Note: Please refer to the machine manufacturer's specifications.</p>
CTRL	+	ALT	+	S	<p><CTRL> + <ALT> + <S> Creates a complete standard archive (.ARC) on an external data carrier (USB-FlashDrive) (for 840D sl). Creates a complete Easy Archive (.ARD) on an external data carrier (USB-FlashDrive) (for 828D).</p> <p>Note: Please refer to the machine manufacturer's specifications.</p>
CTRL	+	ALT	+	D	<p><CTRL> + <ALT> + <D> Backs up the log files on the USB-FlashDrive. If a USB-FlashDrive is not inserted, then the files are backed-up in the manufacturer's area of the CF card.</p>

 +  + 	<p><SHIFT> + <ALT> + <D> Backs up the log files on the USB-FlashDrive. If a USB-FlashDrive is not inserted, then the files are backed-up in the manufacturer's area of the CF card.</p>
 +  + 	<p><SHIFT> + <ALT> + <T> Starts "HMI Trace".</p>
 +  + 	<p><SHIFT> + <ALT> + <T> Exits "HMI Trace".</p>
 + 	<p><ALT> + <S> Opens the editor to enter Asian characters.</p>
 + 	<p><ALT> + <Cursor up> Moves the block start or block end up in the editor.</p>
 + 	<p><ALT> + <Cursor down> Moves the block start or block end down in the editor.</p>
	<p></p> <ul style="list-style-type: none"> • Editing box Deletes the first character to the right of the cursor. • Navigation Deletes all characters.
 + 	<p> + <CTRL></p> <ul style="list-style-type: none"> • Editing box Deletes the first word to the right of the cursor. • Navigation Deletes all characters.
	<p><Spacebar></p> <ul style="list-style-type: none"> • Editing window Inserts a space • Switches between several specified options in selection drop-down list boxes and in selection boxes.
	<p><Plus></p> <ul style="list-style-type: none"> • Opens a directory which contains the element. • Increases the size of the graphic view for simulation and traces.

**<Minus>**

- Closes a directory which contains the element.
- Reduces the size of the graphic view for simulation and traces.

**<Equals>**

Opens the calculator in the entry fields.

**<Asterisk>**

Opens a directory with all of the subdirectories.

**<Tilde>**

Changes the sign of a number between plus and minus.

**<INSERT>**

- Opens an editing window in the insert mode. Pressing the key again, exits the window and the entries are undone.
- Opens a selection box and shows the selection possibilities.
- In the machining step program, enters an empty line for G code.
- Changes into the double editor or into the multi-channel view from the edit mode into the operating mode. You can return to the edit mode by pressing the key again.

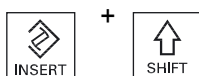
**<INSERT> + <SHIFT>**

For G code programming, for a cycle call activates or deactivates the edit mode.

**<INPUT>**

- Completes input of a value in the entry field.
- Opens a directory or a program.
- Inserts an empty program block if the cursor is positioned at the end of a program block.
- Inserts a character to select a new line and the program block is split up into two parts.
- In the G code, inserts a new line after the program block.
- In the machining step program, inserts a new line for G code e
- Changes into the double editor or into the multi-channel view from the edit mode into the operating mode. You can return to the edit mode by pressing the key again.



<ALARM> - only OP 010 and OP 010C

Calls the "Diagnosis" operating area.



<PROGRAM> - only OP 010 and OP 010C

Calls the "Program Manager" operating area.



<OFFSET> - only OP 010 and OP 010C

Calls the "Parameter" operating area.



<PROGRAM MANAGER> - only OP 010 and OP 010C

Calls the "Program Manager" operating area.



Menu forward key

Advances in the extended horizontal softkey bar.



Menu back key

Returns to the higher-level menu.



<MACHINE>

Calls the "Machine" operating area.



<MENU SELECT>

Calls the main menu to select the operating area.

1.3 Machine control panels

1.3.1 Overview

The machine tool can be equipped with a machine control panel by Siemens or with a specific machine control panel from the machine manufacturer.

You use the machine control panel to initiate actions on the machine tool such as traversing an axis or starting the machining of a workpiece.

1.3.2 Controls on the machine control panel

In this example, the MCP 483C IE machine control panel is used to illustrate the operator controls and displays of a Siemens machine control panel.

Overview

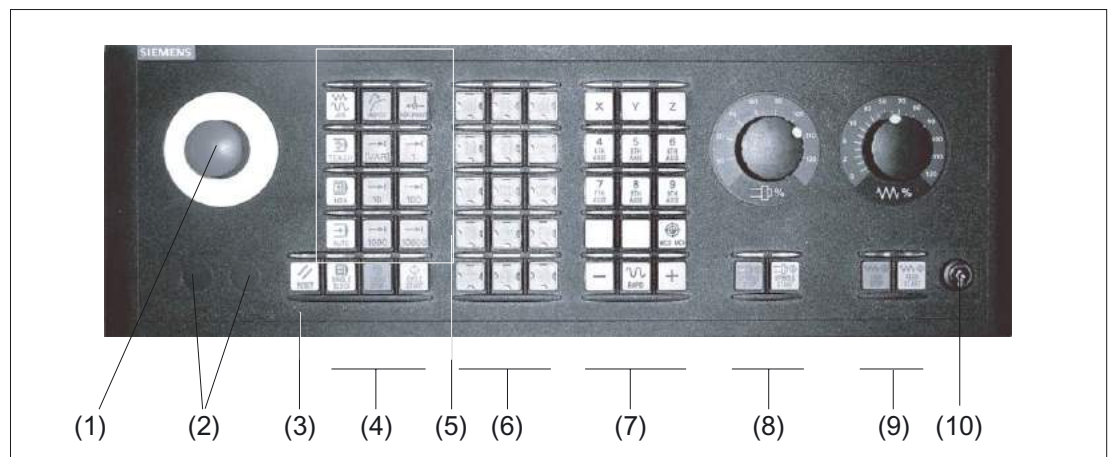

(1)

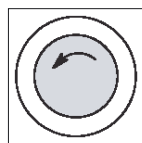















EMERGENCY STOP button

Activate the button in situations where

- life is at risk.
- there is the danger of a machine or workpiece being damaged.

All drives will be stopped with the greatest possible braking torque.

		Machine manufacturer
(2)		For additional responses to pressing the Emergency Stop button, please refer to the machine manufacturer's instructions.
(3)		Installation locations for control devices (d = 16 mm)
		RESET
		<ul style="list-style-type: none"> • Stop processing the current programs. The NCK control remains synchronized with the machine. It is in its initial state and ready for a new program run. • Cancel alarm.
(4)		Program control
		<SINGLE BLOCK>
		Single block mode on/off.
		<CYCLE START>
		The key is also referred to as NC Start. Execution of a program is started.
		<CYCLE STOP>
		The key is also referred to as NC Stop. Execution of a program is stopped.
(5)		Operating modes, machine functions
		<JOG>
		Select "JOG" mode.
		<TEACH IN>
		Select "Teach In" submode.
		<MDI>
		Select "MDI" mode.
		<AUTO>
		Select "AUTO" mode.
		<REPOS>
		Repositions, re-approaches the contour.
		<REF POINT>
		Approach reference point.
		Inc <VAR>(Incremental Feed Variable)
		Incremental mode with variable increment size.
		Inc (incremental feed)
		Incremental mode with predefined increment size of 1, ..., 10000 increments.
	...	
		











- (6)  **Machine manufacturer**
A machine data code defines how the increment value is interpreted.
- (7) **Customer keys**
T1 to T15
- Traversal axes with rapid traverse superposition and coordinate exchange**
- Axis keys**
Selects an axis.
- 
- ...
- 
- Direction keys**
Select the traversing direction.
- 
- ...
- 
- <RAPID>**
Traverse axis in rapid traverse while pressing the direction key.
- 
- <WCS MCS>**
Switches between the workpiece coordinate system (WCS) and machine coordinate system (MCS).
- 
- (8) **Spindle control with override switch**
- <SPINDLE STOP>**
Stop spindle.
- 
- <SPINDLE START>**
Spindle is enabled.
- 
- (9) **Feed control with override switch**
- <FEED STOP>**
Stops execution of the running program and shuts down axis drives.
- 
- <FEED START>**
Enable for program execution in the current block and enable for ramp-up to the feedrate value specified by the program.
- 
- (10) **Keyswitch (four positions)**

Figure 1-2 Front view of machine control panel (milling version)

1.4 User interface

1.4.1 Screen layout

Overview

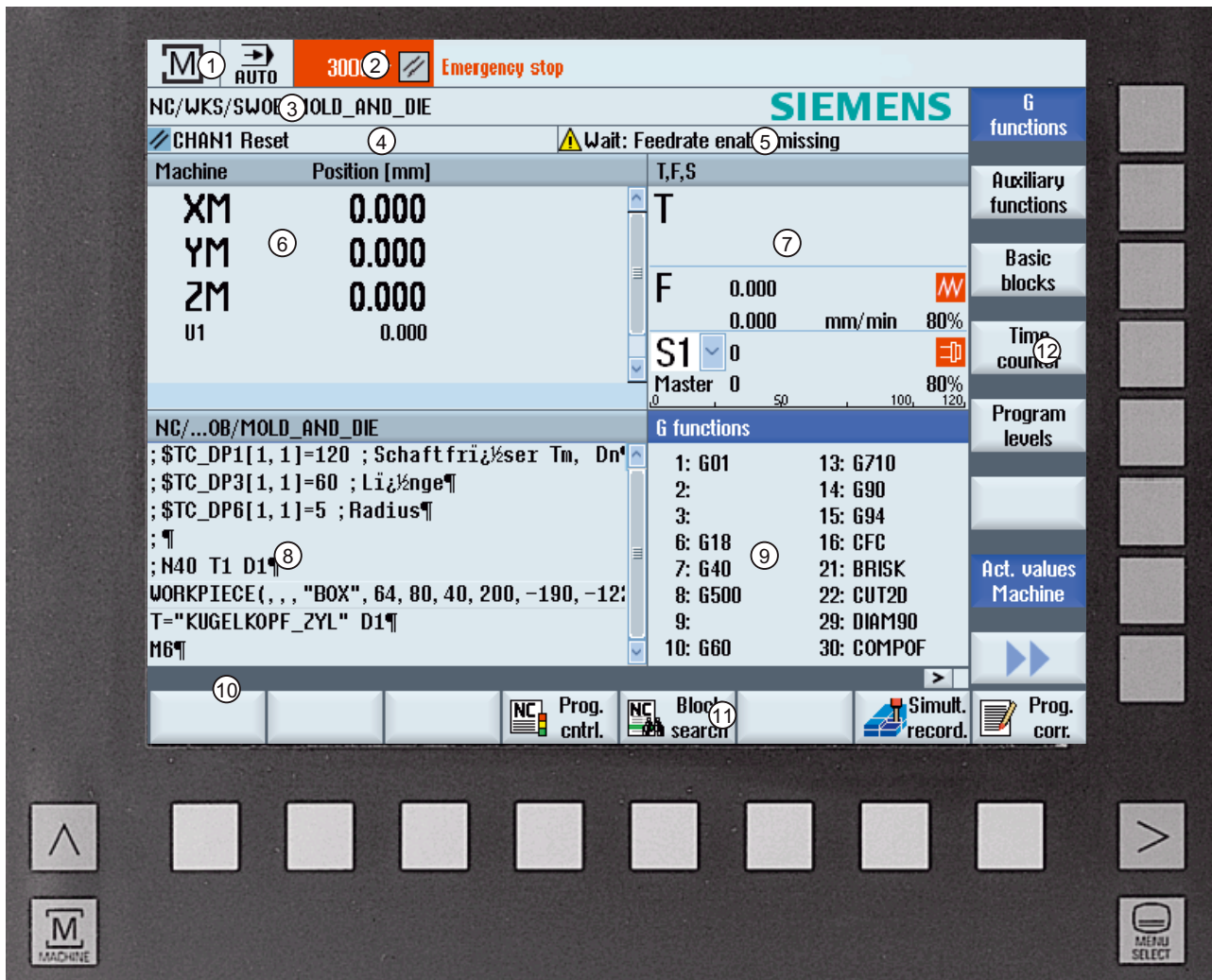

- 1 Active operating area and mode
- 2 Alarm/message line
- 3 Program name
- 4 Channel state and program control
- 5 Channel operational messages
- 6 Axis position display in actual value window

- 7 Display for
 - Active tool T
 - Current feedrate F
 - Active spindle with current status (S)
 - Spindle utilization rate in percent
 - Name of the active tool carrier with display of a rotation in space and plane
 - Name of the active kinematic transformation
- 8 Operating window with program block display
- 9 Display of active G functions, all G functions, auxiliary functions and input window for different functions (for example, skip blocks, program control).
- 10 Dialog line to provide additional user notes.
- 11 Horizontal softkey bar
- 12 Vertical softkey bar

Figure 1-3 User interface

1.4.2 Status display

The status display includes the most important information about the current machine status and the status of the NCK. It also shows alarms as well as NC and PLC messages.

Depending on your operating area, the status display is made up of several lines:

- Large status display

The status display is made up of three lines in the "Machine" operating area.













- Small status display

In the "Parameter", "Program", "Program Manager", "Diagnosis" and "Start-up" operating areas, the status display consists of the first line from the large display.

Status display of "Machine" operating area

First line

Display	Description
Active operating area	
	"Machine" operating area With touch operation, you can change the operating area here.

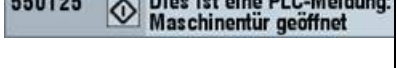
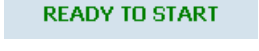
Display	Description
	"Parameter" operating area
	"Program" operating area
	"Program manager" operating area
	"Diagnosis" operating area
	"Start-up" operating area
Active mode or submode	
	"Jog" mode
	"MDA" mode
	"Auto" mode
	"Teach In" submode
	"Repos" submode
	"Ref Point" submode
Alarms and messages	
	<p>Alarm display</p> <p>The alarm numbers are displayed in white lettering on a red background. The associated alarm text is shown in red lettering.</p> <p>An arrow indicates that several alarms are active.</p> <p>An acknowledgment symbol indicates that the alarm can be acknowledged or canceled.</p>
	<p>NC or PLC message</p> <p>Message numbers and texts are shown in black lettering.</p> <p>An arrow indicates that several messages are active.</p>
	Messages from NC programs do not have numbers and appear in green lettering.

Second line

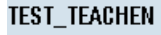
Display	Description
	Program path and program name







The displays in the second line can be configured.



Machine manufacturer

Please also refer to the machine manufacturer's instructions.

Third line

Display	Description
	<p>Display of channel status.</p> <p>If several channels are present on the machine, the channel name is also displayed.</p> <p>If only one channel is available, only the "Reset" channel status is displayed.</p> <p>With touch operation, you can change the channel here.</p>
  	<p>Display of channel status:</p> <p>The program was aborted with "Reset".</p> <p>The program is started.</p> <p>The program has been interrupted with "Stop".</p>
	<p>Display of active program controls:</p> <p>PRT: no axis motion</p> <p>DRY: Dry run feedrate</p> <p>RG0: reduced rapid traverse</p> <p>M01: programmed stop 1</p> <p>M101: programmed stop 2 (name varies)</p> <p>SB1: Single block, coarse (program stops only after blocks which perform a machine function)</p> <p>SB2: Data block (program stops after each block)</p> <p>SB3: Single block, fine (program also only stops after blocks which perform a machine function in cycles)</p>
 	<p>Channel operational messages:</p> <p>Stop: An operator action is usually required.</p> <p>Wait: No operator action is required.</p>

The machine manufacturer settings determine which program controls are displayed.



Machine manufacturer

Please also refer to the machine manufacturer's instructions.

1.4.3 Actual value window

The actual values of the axes and their positions are displayed.

Work/Machine

The displayed coordinates are based on either the machine coordinate system or the workpiece coordinate system. The machine coordinate system (Machine), in contrast to the workpiece coordinate system (Work), does not take any work offsets into consideration.

You can use the "Machine actual values" softkey to toggle between the machine coordinate system and the workpiece coordinate system.

The actual value display of the positions can also refer to the SZS coordinate system (settable zero system). However the positions are still output in the Work.

The ENS coordinate system corresponds to the Work coordinate system, reduced by certain components (\$P_TRAFRAME, \$P_PFRAME, \$P_ISO4FRAME, \$P_CYCFRAME), which are set by the system when machining and are then reset again. By using the ENS coordinate system, jumps into the actual value display are avoided that would otherwise be caused by the additional components.



Machine manufacturer

Please refer to the machine manufacturer's specifications.



Maximize display



Press the ">>" and "Zoom act.val." softkeys.



Overview of display

Display	Meaning	
Header columns		
Work/Machine	Display of axes in selected coordinate system.	
Position	Position of displayed axes.	
Display of distance-to-go	The distance-to-go for the current NC block is displayed while the program is running.	
Feed/override	The feed acting on the axes, as well as the override, are displayed in the full-screen version.	
Repos offset	The distances traversed in manual mode are displayed. This information is only displayed when you are in the "Repos" submode.	
Collision monitoring (only 840D sl)		The collision avoidance is switched on for the JOG and MDI or AUTOMATIC modes and at least one active collision pair is present.
		The collision avoidance is switched off for the JOG and MDI or AUTOMATIC modes or no active collision pair is present.
Footer	Display of active work offsets and transformations. The T, F, S values are also displayed in the full-screen version.	



See also

Overview (Page 78)
Zero offsets (Page 113)

1.4.4 T,F,S window

The most important data concerning the current tool, the feedrate (path feed or axis feed in JOG) and the spindle is displayed in the T, F, S window.

In addition to the "T, F, S" window name, the following information is also displayed:

Display	Meaning
BC (example)	Name of the tool carrier
Turning (example)	Name of the active kinematic transformation
	Active tool carrier rotated in the plane
	Active tool carrier swiveled in space





Tool data

Display	Meaning
T	
Tool name	Name of the current tool
Location	Location number of the current tool
D	Cutting edge of the current tool The tool is displayed with the associated tool type symbol corresponding to the actual coordinate system in the selected cutting edge position. If the tool is swiveled, then this is taken into account in the display of the cutting edge position. In DIN-ISO mode the H number is displayed instead of the cutting edge number.
H	H number (tool offset data record for DIN-ISO mode) If there is a valid D number, this is also displayed.
Ø	Diameter of the current tool
R	Radius of the current tool
Z	Z value of the current tool
X	X value of the current tool

Feed data

Display	Meaning
F	
	Feed disable
	Actual feed value If several axes traverse, is displayed for: <ul style="list-style-type: none"> • "JOG" mode: Axis feed for the traversing axis • "MDA" and "AUTO" mode: Programmed axis feed
Rapid traverse	G0 is active
0.000	No feed is active
Override	Display as a percentage

Spindle data

Display	Meaning
S	
S1	Spindle selection, identification with spindle number and main spindle
Speed	Actual value (when spindle turns, display increases) Setpoint (always displayed, also during positioning)
Symbol	Spindle status
	Spindle not enabled
	Spindle is turning clockwise
	Spindle is turning counterclockwise
	Spindle is stationary
Override	Display as a percentage
Spindle utilization rate	Display between 0 and 100% The upper limit value can be greater than 100%. See machine manufacturer's specifications.

Note

Display of logical spindles

If the spindle converter is active, logical spindles are displayed in the workpiece coordinate system. When switching over to the machine coordinate system, the physical spindles are displayed.



Machine manufacturer

Please refer to the machine manufacturer's specifications.

1.4.5 Current block display

The window of the current block display shows you the program blocks currently being executed.

Display of current program

The following information is displayed in the running program:

- The workpiece name or program name is entered in the title row.
- The program block which is just being processed appears colored.

Editing a program directly

In the Reset state, you can edit the current program directly.



1. Press the <INSERT> key.

2. Place the cursor at the relevant position and edit the program block.
Direct editing is only possible for G code blocks in the NC memory, not for external execution.



3. Press the <INSERT> key to exit the program and the edit mode again.

1.4.6 Operation via softkeys and buttons

Operating areas/operating modes

The user interface consists of different windows featuring eight horizontal and eight vertical softkeys.

You operate the softkeys with the keys next to the softkey bars.

You can display a new window or execute functions using the softkeys.

The operating software is sub-divided into six operating areas (machine, parameter, program, program manager, diagnosis, startup) and five operating modes or submodes (JOG, MDA, AUTO, TEACH IN, REF POINT, REPOS).

Changing the operating area



Press the <MENU SELECT> key and select the desired operating area using the horizontal softkey bar.

You can call the "Machine" operating area directly using the key on the operator panel.



Press the <MACHINE> key to select the "machine" operating area.

Changing the operating mode

You can select a mode or submode directly using the keys on the machine control panel or using the vertical softkeys in the main menu.

General keys and softkeys



When the  symbol appears to the right of the dialog line on the user interface, you can change the horizontal softkey bar within an operating area. To do so, press the menu forward key.

The  symbol indicates that you are in the expanded softkey bar. Pressing the key again will take you back to the original horizontal softkey bar.



Use the ">>" softkey to open a new vertical softkey bar.



Use the "<<" softkey to return to the previous vertical softkey bar.



Use the "Return" softkey to close an open window.



Use the "Cancel" softkey to exit a window without accepting the entered values and return to the next highest window.



When you have entered all the necessary parameters in the parameter screen form correctly, you can close the window and save the parameters using the "Accept" softkey. The values you entered are applied to a program.



Use the "OK" softkey to initiate an action immediately, e.g. to rename or delete a program.

1.4.7 Entering or selecting parameters

When setting up the machine and during programming, you must enter various parameter values in the entry fields. The background color of the fields provides information on the status of the entry field.

Orange background	The input field is selected
Light orange background	The input field is in edit mode
Pink background	The entered value is incorrect

Selecting parameters

Some parameters require you to select from a number of options in the input field. Fields of this type do not allow you to type in a value.

The selection symbol is displayed in the tooltip:

Associated selection fields

There are selection fields for various parameters:

- Selection of units
- Changeover between absolute and incremental dimensions

Procedure



1. Keep pressing the <SELECT> key until the required setting or unit is selected.

The <SELECT> key only works if there are several selection options available.

- OR -



Press the <INSERT> key.

The selection options are displayed in a list.



2. Select the required setting using the <Cursor down> and <Cursor up> keys.

3. If required, enter a value in the associated input field.



4. Press the <INPUT> key to complete the parameter input.

Changing or calculating parameters

If you only want to change individual characters in an input field rather than overwriting the entire entry, switch to insertion mode.

In this mode, you can also enter simple calculation expressions, without having to explicitly call the calculator. You can execute the four basic calculation types, work with expressions in brackets as well as generate square roots and squares.

Note

Generating square roots and squares

The extract roots and generate square functions is not available in the parameter screens of the cycles and functions in the "Program" operating area.



Press the <INSERT> key.

The insert mode is activated.



You can navigate within the input field using the <Cursor left> and <Cursor right> keys.



Use the <BACKSPACE> and key to delete individual characters.





+ <*>

Enter the multiplication characters using the <SHIFT> + <*> keys.



+ </>

Enter the division character using the <SHIFT> + </> keys.



Enter bracket expressions using the <SHIFT> + <(> and <SHIFT> + <)> keys.



+ <(>



+ <number> Enter "r" or "R" as well as the number x from which you would like to extract the root.



+ <number> Enter "s" or "S" as well as the number x for which you would like to generate the square.



Close the value entry using the <INPUT> key and the result is transferred into the field.

Accepting parameters

When you have correctly entered all necessary parameters, you can close the window and save your settings.

You cannot accept the parameters if they are incomplete or obviously erroneous. In this case, you can see from the dialog line which parameters are missing or were entered incorrectly.



Press the "OK" softkey.

- OR -



Press the "Accept" softkey.

1.4.8 Pocket calculator

You can use the calculator to quickly calculate parameter values during programming. If, for example, the diameter of a workpiece is only dimensioned indirectly in the workpiece drawing, i.e., the diameter must be derived from the sum of several other dimension specifications, you can calculate the diameter directly in the input field of this parameter.

Calculation methods

The following arithmetic operations are available:

- Addition
- Subtraction
- Multiplication
- Division
- Calculation with parentheses
- Square root of x
- x squared

You can input a maximum of 256 characters in a field.

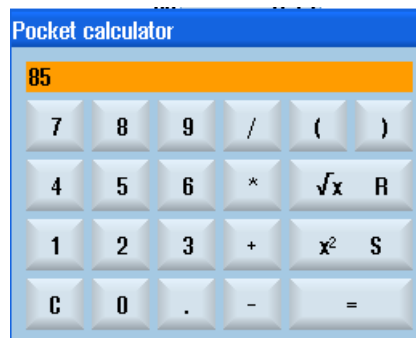

Procedure



1. Position the cursor on the desired entry field.
2. Press the <=> key.

The calculator is displayed.

3. Input the arithmetic statement.
You can use arithmetic symbols, numbers, and commas.
4. Press the equals symbol on the calculator.

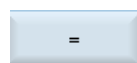

- OR -



Press the "Calculate" softkey.

- OR -



Press the <INPUT> key.

The new value is calculated and displayed in the entry field of the calculator.



5. Press the "Accept" softkey.

The calculated value is accepted and displayed in the entry field of the window.

Note

Input order for functions

When using the square root or squaring functions, make sure to press the "R" or "S" function keys, respectively, before entering a number.

1.4.9 Context menu

When you right-click, the context menu opens and provides the following functions:

- Cut
Cut Ctrl+X
- Copy
Copy Ctrl+C
- Paste
Paste Ctrl+V

Program editor

Additional functions are available in the editor

- Undo the last change
Undo Ctrl+Z
- Redo the changes that were undone
Redo Ctrl+Y

Up to 10 changes can be undone.

1.4.10 Touch operation

If you have an operator panel with a touch screen, you can perform the following functions with touch operation:

Operating area switchover



You can display the operating area menu by touching the display symbol for the active operating area in the status display.



Channel switchover



You can switch over to the next channel by touching the channel display in the status display.

1.4.11 Changing the user interface language

Procedure

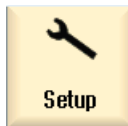

1. Select the "Start-up" operating area.



2. Press the "Change language" softkey.
The "Language selection" window opens. The language set last is selected.



3. Position the cursor on the desired language.
4. Press the "OK" softkey.

- OR -



Press the <INPUT> key.

The user interface changes to the selected language.

Note

Changing the language directly on the input screens

You can switch between the user interface languages available on the controller directly on the user interface by pressing the key combination <CTRL + L>.

1.4.12 Entering Asian characters

You have the possibility of entering Asian characters.

Note

Call the input editor with <Alt + S>

The input editor can only be called there where it is permissible to enter Asian characters.

You can select a character by using the Pinyin phonetic notation, which enables Chinese characters to be expressed by combining Latin letters.

The editor is available for the following Asian languages:

- Simplified Chinese
- Traditional Chinese
- Korean



Note

You require a special keyboard to enter Korean characters.

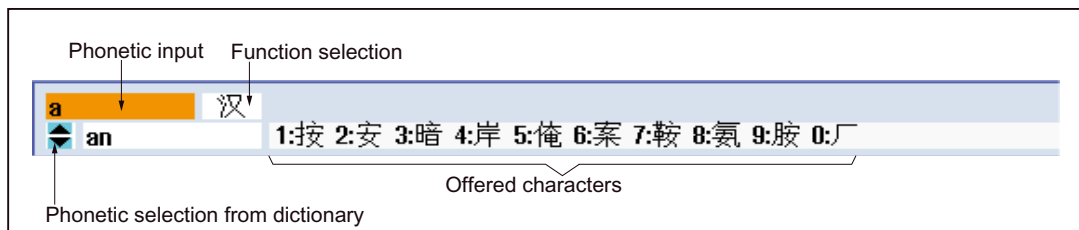
Structure of editor



Functions





-  Pinyin input
-  Editing of the dictionary
-  Input of Latin letters

Precondition

The control has been set to Chinese or Korean.

Procedure

Editing characters

1.  Open the screen form and position the cursor on the entry field and press the <Alt +S> keys.
The editor is displayed.
2.  Enter the desired phonetic notation.
3.  Click the <Cursor down> key to access the dictionary.
4. By keeping the <Cursor down> key pressed, displays all the entered phonetic notations and the associated selection characters.
5.  Press the <BACKSPACE> softkey to delete entered phonetic notations.
6. Press the number key to insert the associated character.
When a character is selected, the editor records the frequency with which it is selected for a specific phonetic notation and offers this character at the top of the list when the editor is next opened.

Editing the dictionary

1.  Select the dictionary editing function in the selection box.
The editor provides a further line in which the combined characters and phonetic notations are displayed.

2. Enter the desired phonetic notation in the phonetic input field.
Various characters are displayed for this phonetic notation, from which you can select a character by entering either of the appropriate number (1 to 9).



You can toggle the input cursor between the compound phonetic notations field and the phonetic input field by pressing the <TAB> key. Combined characters are cancelled via the <BACKSPACE> key.



3. Press the <SELECT> key to take a combined phonetic notation into the dictionary.

1.4.13 Protection levels

The input and modification of data in the control system is protected by passwords at sensitive places.

Access protection via protection levels

The input or modification of data for the following functions depends on the protection level setting:

- Tool offsets
- Zero offsets
- Setting data
- Program creation / program editing

Note

Configuring access levels for softkeys

You have the option of providing softkeys with protection levels or completely hiding them.

References





For additional information, please refer to the following documentation:





Commissioning Manual SINUMERIK Operate (IM9) / SINUMERIK 840D sl



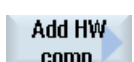

Softkeys

Machine operating area	Protection level
	End user (protection level 3)

Parameters operating area	Protection level
Tool management lists 	Keyswitch 3 (protection level 4)

Diagnostics operating area	Protection level
	Keyswitch 3 (protection level 4)
	User (protection level 3)
	User (protection level 3)
	Manufacturer (protection level 1)
	User (protection level 3)
	Service (protection level 2)

Start-up operating area	Protection levels
	End user (protection level 3)
	Keyswitch 3 (protection level 4)
 	Keyswitch 3 (protection level 4)

Start-up operating area	Protection levels
 Licenses	Keyswitch 3 (protection level 4)
 Set MD active (cf)	Keyswitch 3 (protection level 4)
 NCK	Service (protection level 2)
 Change password	End user (protection level 3)
 Delete password	End user (protection level 3)

1.4.14 Online help in SINUMERIK Operate

A comprehensive context-sensitive online help is stored in the control system.

- A brief description is provided for each window and, if required, step-by-step instructions for the operating sequences.
- A detailed help is provided in the editor for every entered G code. You can also display all G functions and take over a selected command directly from the help into the editor.
- A help page with all parameters is provided on the input screen in the cycle programming.
- Lists of the machine data
- Lists of the setting data
- Lists of the drive parameters
- List of all alarms

Procedure

Calling context-sensitive online help



1. You are in an arbitrary window of an operating area.
2. Press the <HELP> key or on an MF2 keyboard, the <F12> key.
The help page of the currently selected window is opened in a subscreen.



3. Press the "Full screen" softkey to use the entire user interface for the display of the online help.



Press the "Full screen" softkey again to return to the subscreen.



4. If further helps are offered for the function or associated topics, position the cursor on the desired link and press the "Follow reference" softkey.
The selected help page is displayed.

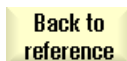

5. Press the "Back to reference" softkey to jump back to the previous help.

Calling a topic in the table of contents

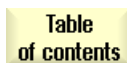

1. Press the "Table of contents" softkey.
Depending on which technology you are using, the Operating Manuals "Operator control Milling", "Operator control Turning" or "Operator control Universal" as well as the "Programming" Programming Manual are displayed.



2. Select the desired manual with the <Cursor down> and <Cursor up> keys.



3. Press the <Cursor right> or <INPUT> key or double-click to open the manual and the section.



4. Navigate to the desired topic with the "Cursor down" key.



5. Press the <Follow reference> softkey or the <INPUT> key to display the help page for the selected topic.





6. Press the "Current topic" softkey to return to the original help.

Searching for a topic



1. Press the "Search" softkey.
The "Search in Help for:" window is opened.

2. Activate the "Full text " checkbox to search in all help pages.
If the checkbox is not activated, a search is performed in the table of contents and in the index.

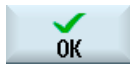

3. Enter the desired keyword in the "Text" field and press the "OK" softkey.
If you enter the search term on the operator panel, replace an umlaut (accented character) by an asterisk (*) as dummy.

All entered terms and sentences are sought with an AND operation. In this way, only documents and entries that satisfy all the search criteria are displayed.



4. Press the "Keyword index" softkey if you only want to display the index of the operating and programming manual.

Displaying alarm descriptions and machine data



1. If messages or alarms are pending in the "Alarms", "Messages" or "Alarm Log" window, position the cursor at the appropriate display and press the <HELP> or the <F12> key.

The associated alarm description is displayed.



2. If you are in the "Start-up" operating area in the windows for the display of the machine, setting and drive data, position the cursor on the desired machine data or drive parameter and press the <HELP> or the <F12> key.

The associated data description is displayed.

Displaying and inserting a G code command in the editor



1. A program is opened in the editor.
Position the cursor on the desired G code command and press the <HELP> or the <F12> key.

The associated G code description is displayed.



2. Press the "Display all G functions" softkey.



3. With the aid of the search function, select, for example, the desired G code command.



4. Press the "Transfer to editor" softkey.
The selected G function is taken into the program at the cursor position.

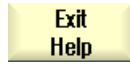

5. Press the "Exit help" softkey again to close the help.

See also

Additional functions in the input screens (Page 248)

Setting up the machine

2.1 Switching on and switching off

Start-up

Machine	Position [mm]	Feed/override
X1	0.000	0.000 mm/min 80%
Y1	0.000	0.000 mm/min 80%
Z1	0.000	0.000 mm/min 80%
SP1	0.000 °	0.000 °/min 80%

F=0.000

When the control starts up, the main screen opens according to the operating mode specified by the machine manufacturer. In general, this is the main screen for the "REF POINT" submode.



Machine manufacturer

Please also refer to the machine manufacturer's instructions.

2.2 Approaching a reference point

2.2.1 Referencing axes

Your machine tool can be equipped with an absolute or incremental path measuring system. An axis with incremental path measuring system must be referenced after the controller has been switched on – however, an absolute path measuring system does not have to be referenced.

For the incremental path measuring system, all the machine axes must therefore first approach a reference point, the coordinates of which are known to be relative to the machine zero-point.

Sequence

Prior to the approach, the axes must be in a position from where they can approach the reference point without a collision.

The axes can also all approach the reference point simultaneously, depending on the manufacturer's settings.



Machine manufacturer

Please refer to the machine manufacturer's specifications.

NOTICE

Risk of collision

If the axes are not in a collision-free position, you must first traverse them to safe positions in "JOG" or "MDI" mode.

You must follow the axis motions directly on the machine!

Ignore the actual value display until the axes have been referenced!

The software limit switches are not active!

Procedure



1. Press the <JOG> key.



2. Press the <REF. POINT> key.



3. Select the axis to be traversed.



4. Press the <-> or <+> key.

The selected axis moves to the reference point.



If you have pressed the wrong direction key, the action is not accepted and the axes do not move.



A symbol is shown next to the axis if it has been referenced.

The axis is referenced as soon as the reference point is reached. The actual value display is set to the reference point value.

From now on, path limits, such as software limit switches, are active.

End the function via the machine control panel by selecting operating mode "AUTO" or "JOG".

2.2.2 User agreement

If you are using Safety Integrated (SI) on your machine, you will need to confirm that the current displayed position of an axis corresponds to its actual position on the machine when you reference an axis. Your confirmation is the requirement for the availability of other Safety Integrated functions.

You can only give your user agreement for an axis after it has approached the reference point.

The displayed axis position always refers to the machine coordinate system (Machine).

Option

User agreement with Safety Integrated is only possible with a software option.

Procedure



1. Select the "Machine" operating area.



2. Press the <REF POINT> key.



3. Select the axis to be traversed.

4. Press the <-> or <+> key.

The selected axis moves to the reference point and stops. The coordinate of the reference point is displayed.

The axis is marked with

5. Press the "User enable" softkey.

The "User Agreement" window opens.

It shows a list of all machine axes with their current position and SI position.

5. Position the cursor in the "Acknowledgement" field for the axis in question.

6. Activate the acknowledgement with the <SELECT> key.

The selected axis is marked with an "x" meaning "safely referenced" in the "Acknowledgement" column.

By pressing the <SELECT> key again, you deactivate the acknowledgement again.

2.3 Operating modes

2.3.1 General

You can work in three different operating modes.

"JOG" mode

"JOG" mode is used for the following preparatory actions:

- Approach reference point, i.e. the machine axis is referenced
- Preparing a machine for executing a program in automatic mode, i.e. measuring tools, measuring the workpiece and, if necessary, defining the work offsets used in the program
- Traversing axes, e.g. during a program interruption
- Positioning axes

Select "JOG"



Press the <JOG> key.

"REF POINT" operating mode

The "REF POINT" operating mode is used to synchronize the control and the machine. For this purpose, you approach the reference point in "JOG" mode.

Selecting "REF POINT"



Press the <REF POINT> key.

"REPOS" operating mode

The "REPOS" operating mode is used for repositioning to a defined position. After a program interruption (e.g. to correct tool wear values) move the tool away from the contour in "JOG" mode.

The distances traversed in "JOG" mode are displayed in the actual value window as the "Repos" offset.

"REPOS" offsets can be displayed in the machine coordinate system (MCS) or workpiece coordinate system (WCS).

Selecting "Repos"



Press the <REPOS> key.

"MDI" mode (Manual Data Input)

In "MDI" mode, you can enter and execute G code commands non-modally to set up the machine or to perform a single action.

Selecting "MDI"



Press the <MDI> key.

"AUTO" mode

In automatic mode, you can execute a program completely or only partially.

Select "AUTO"



Press the <AUTO> key.

"TEACH IN" operating mode

"TEACH IN" is available in the "AUTO" and "MDI" operating modes.

There you may create, edit and execute part programs (main programs or subroutines) for motional sequences or simple workpieces by approaching and saving positions.

Selecting "Teach In"



Press the <TEACH IN> key.

2.3.2 Modes groups and channels

Every channel behaves like an independent NC. A maximum of one part program can be processed per channel.

- Control with 1 channel
One mode group exists.
- Control with several channels
Channels can be grouped to form several "mode groups."

Example

Control with 4 channels, where machining is carried out in 2 channels and 2 other channels are used to control the transport of the new workpieces.

Mode group 1 channel 1 (machining)

Channel 2 (transport)

Mode group 2 channel 3 (machining)

Channel 4 (transport)

Mode groups (MGs)

Technologically-related channels can be combined to form a mode group.

Axes and spindles of the same mode group can be controlled by one or more channels.

An operating mode group is in one of "Automatic", "JOG" or "MDI" operating modes, i.e., several channels of an operating mode group can never assume different operating modes.

2.3.3 Channel switchover

It is possible to switch between channels when several are in use. Since individual channels may be assigned to different mode groups, a channel switchover command is also an implicit mode switchover command.

When a channel menu is available, all of the channels are displayed on softkeys and can be switched over.

Changing the channel



Press the <CHANNEL> key.

The channel changes over to the next channel.

- OR -

If the channel menu is available, a softkey bar is displayed. The active channel is highlighted.

Another channel can be selected by pressing one of the other softkeys.

References

Commissioning Manual SINUMERIK Operate (IM9) / SINUMERIK 840D sl

Channel switchover via touch operation

On the HT 8 and when using a touch screen operator panel, you can switch to the next channel or display the channel menu via touch operation in the status display.

2.4 Settings for the machine

2.4.1 Switching over the coordinate system (MCS/WCS)

The coordinates in the actual value display are relative to either the machine coordinate system or the workpiece coordinate system.

By default, the workpiece coordinate system is set as a reference for the actual value display.

The machine coordinate system (MCS), in contrast to the workpiece coordinate system (WCS), does not take into account any zero offsets, tool offsets and coordinate rotation.

Procedure



1. Select the "Machine" operating area.



2. Press the <JOG> or <AUTO> key.



3. Press the "Act.vls. MCS" softkey.



The machine coordinate system is selected.
The title of the actual value window changes in the MCS.



Machine manufacturer

The softkey to changeover the coordinate system can be hidden. Please refer to the machine manufacturer's specifications.

2.4.2 Switching the unit of measurement

You can set millimeters or inches as the unit of measurement. Switching the unit of measurement always applies to the entire machine. All required information is automatically converted to the new unit of measurement, for example:

- Positions
- Tool offsets
- Work offsets



Machine manufacturer

Please also refer to the machine manufacturer's instructions.

Proceed as follows



1. Select <JOG> or <AUTO> mode in the "Machine" operating area.



2. Press the menu forward key and the "Settings" softkey.
A new vertical softkey bar appears.



3. Press the "Switch to inch" softkey.
A prompt asks you whether you really want to switch over the unit of measurement.



4. Press the "OK" softkey.

The softkey label changes to "Switch to metric".

The unit of measurement applies to the entire machine.



5. Press the "Switch to metric" softkey to set the unit of measurement of the machine to metric again.

2.4.3 Setting the zero offset

You can enter a new position value in the actual value display for individual axes when a settable zero offset is active.

The difference between the position value in the machine coordinate system MCS and the new position value in the workpiece coordinate system WCS is saved permanently in the currently active zero offset (e.g. G54).

Relative actual value

Further, you also have the possibility of entering position values in the relative coordinate system.

Note

The new actual value is only displayed. The relative actual value has no effect on the axis positions and the active zero offset.

Resetting the relative actual value



Press the "Delete REL" softkey.

The actual values are deleted.

The softkeys to set the zero point in the relative coordinate system are only available if the corresponding machine data is set.



Machine manufacturer

Please refer to the machine manufacturer's specifications.

Precondition

The controller is in the workpiece coordinate system.

The actual value is set in the reset state.

Note

Setting the ZO in the Stop state

If you enter the new actual value in the Stop state, the changes made are only visible and only take effect when the program is continued.

Procedure



1. Select the "JOG" mode in the "Machine" operating area.



2. Press the "Set ZO" softkey.

- OR -



Press the ">>", "REL act. vals" and "Set REL" softkeys to set position values in the relative coordinate system.



3. Enter the new required position value for X, Y or Z directly in the actual value display (you can toggle between the axes with the cursor keys) and press the "Input" key to confirm the entries.

- OR -

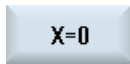

Press softkeys "X=0", "Y=0" or "Z=0" to set the relevant position to zero.

...

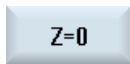

- OR -

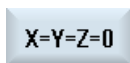

Press softkey "X=Y=Z=0" to set all axis positions to zero simultaneously.

Resetting the actual value



Press the "Delete active ZO" softkey.

The offset is deleted permanently.

Note

Irreversible active zero offset

The current active zero offset is irreversibly deleted by this action.

2.5 Measuring the tool

The geometries of the machining tool must be taken into consideration when executing a part program. These are stored as tool offset data in the tool list. Each time the tool is called, the control considers the tool offset data.

When programming the part program, you only need to enter the workpiece dimensions from the production drawing. After this, the controller independently calculates the individual tool path.

You can determine the tool offset data, i.e. the length and radius or diameter, either manually or automatically with tool probes.

See also

Tool dimensioning (Page 527)

Measuring the tool (Page 540)

2.5.1 Measuring a tool manually

For manual measurement, move the tool manually to a known reference point to determine the tool length and the radius or diameter. The control then calculates the tool offset data from the position of the tool carrier reference point and the reference point.

Reference point

When measuring the tool length you can either use the workpiece or a fixed point in the machine coordinate system, e.g. a mechanical test socket or a fixed point in combination with a distance gauge as the reference point.

When determining the radius/diameter, the workpiece is always used as the reference point

In the machine data, you define whether the radius or the diameter of the tool is to be measured.



Machine manufacturer

Please refer to the machine manufacturer's specifications.

Note

You can enter the position of the workpiece during measurement.

However, you must declare the position of the fixed point before the measurement.

See also

Fixed point calibration (Page 74)

2.5.2 Measuring the tool length with the workpiece as reference point

Procedure



1. Insert the tool you want to measure in the spindle.
2. Select "JOG" mode in the "Machine" operating area.
3. Press the "Meas. tool" and "Length manual" softkeys. The "Length Manual" window opens.
4. Select the cutting edge number D and the number of the replacement tool ST of the tool.
5. Approach the workpiece in the Z direction, scratch it with a turning spindle and enter the set position Z0 of the workpiece edge.
6. Press the "Set length" softkey. The tool length is calculated automatically and entered in the tool list.

Note

Tool measurement is only possible with an active tool.

2.5.3 Measuring radius or diameter

Procedure



1. Insert the tool you want to measure in the spindle.
Select "JOG" mode in the "Machine" operating area.
2. Press the "Meas. tool" softkey.
3. Press the "Radius manual" or "Diam. manual" softkey.
4. Select the cutting edge number D and the the number of the replacement tool ST.
5. Approach the workpiece in the X or Y direction and perform scratching with the spindle rotating in the opposite direction.
6. Specify the setpoint position X0 or Y0 of the workpiece edge.
7. Press the "Set radius" or "Set diam." softkey.
The tool radius or diameter is calculated automatically and entered in the tool list.

Note

Tool measurement is only possible with an active tool.

2.5.4 Fixed point calibration

If you want to use a fixed point as the reference point in manual measurement of the tool length, you must first determine the position of the fixed point relative to the machine zero.

Test socket

You can use a mechanical test socket as the fixed point, for example. Mount the test socket on the machine table in the machining space of the machine. Enter zero as the distance.

Distance gauge

However, you can also use any fixed point on the machine in combination with a distance gauge. Enter the thickness of the plate as "DZ".

To calibrate the fixed point, use either a tool whose length is known (i.e. the tool length must be entered in the tool list) or the spindle directly.

The position of the fixed point may have already been determined by the machine manufacturer.



Machine manufacturer

Please refer to the machine manufacturer's specifications.

Procedure



1. Traverse the tool or spindle to the fixed point.
2. Press the "Measure tool" softkey in the "JOG" mode.
3. Press the "Calibrate fixed point" softkey.
4. Enter a correction value for "DZ".
If you have used a distance gauge, enter the thickness of the plate used.
5. Press the "Calibrate" softkey.
6. The distance between machine zero and fixed point is calculated and entered in the machine data.

2.5.5 Measuring a tool with an electrical tool probe

For automatic measurement, you determine the length and radius or diameter of the tool with the aid of a tool probe (table contact system). The control uses the known positions of the toolholder reference point and tool probe to calculate the tool offset data.

Use the softkey to select whether you want to measure the length, the radius or the diameter of the tool.

The corresponding windows can be adapted to the measurement tasks in order to automatically measure tools.

Adapting the user interface to calibrating and measuring functions

The following selection options can be switched-in or switched-out:

- Calibration plane, measurement plane
- Probe
- Calibration feedrate (measuring feedrate)



Machine manufacturer

Please refer to the machine manufacturer's specifications.

Requirements

- No function-related settings are necessary after the measuring cycles have been installed.
- Before the actual measurement, enter approximate values for length and radius or diameter of the tool in the tool list.
- Calibrate the probe first.



Machine manufacturer

Please refer to the machine manufacturer's specifications.

Lateral/longitudinal offset

If the widest part of the tool is not at the outer edge of the tool or the longest part is not at the bottom edge of the tool, you can store this difference in the offset.









If measuring shows that the length of the tool diameter is greater than the probe diameter, measurement is automatically performed with rotating spindle.

Tooth break monitoring

Before or after machining you can check if any cutting edges of the milling tool have broken off.

If it is noticed during the check of the cutting edges that not all cutting edges or teeth are present, you will receive a corresponding message.

Procedure

1. Insert the tool that you want to measure.
2. Select "JOG" mode in the "Machine" operating area.

3. Press the "Meas. tool" softkey.

4. Press the "Length auto" softkey if you want to measure the length of the tool.

- OR -
Press the "Radius auto" or "Diam. Auto", if you wish to measure the radius or diameter of the tool.

5. Select the cutting edge number D and the number of the replacement tool ST.

6. If you wish to check the cutting edges of the milling tool, then click "Yes" under "Check teeth individually".

7. If necessary, enter the lateral offset V.
8. Press the <CYCLE START> key.

This starts the automatic measuring process. When you measure the tool radius or diameter, measurement is performed with a spindle rotating in the opposite direction.
The tool length, radius, and diameter are calculated automatically and entered in the tool list.

Note

Tool measurement is only possible with an active tool.

2.5.6 Calibrating the electrical tool probe

If you want to measure your tools automatically, you must first determine the position of the tool probe on the machine table with reference to the machine zero.

Tool probes are typically shaped like a cube or a cylindrical disk. Install the tool probe in the working area of the machine (e.g. on the machine table) and align it relative to the machining axes.

You must use a mill-type calibration tool to calibrate the tool probe. You must enter the length and radius/diameter of the calibration tool in the tool list beforehand.

Calibration of a tool probe with rotation

To compensate radial eccentricity of the spindle or position deviations of the calibrating tool when calibrating the tool probe, you have the option to calibrate the tool probe with rotation. This entails more exact calibration values of the tool probe and thus more exact measuring values.

During calibration, the probe is withdrawn after the first scanning operation, the spindle is rotated by 180° and again the scanning operation is performed. A mean value of two values is then determined and entered.

Note

Setting the protection level

The "Calibrate probe" function is only available if an adequate level of protection is set.

Please refer to the machine manufacturer's specifications.

Procedure



1. Move the calibration tool until it is approximately over the center of the measuring surface of the tool probe.
2. Select operating mode "JOG" in the "Machine" operating area and press the "Measure tool" softkey.
3. Press the "Calibrate probe" softkey.
4. Choose whether you want to calibrate the length only, or the length and the diameter.



5. Click in the selection field "Spindle rotation" entry "Yes" if you want to perform the "Calibration with rotation".



6. Press the <CYCLE START> key.
Calibration is automatically executed at the measuring feedrate. The distance measurements between the machine zero and tool probe are calculated and stored in an internal data area.

2.6 Measuring the workpiece zero

2.6.1 Overview

The reference point for programming a workpiece is always the workpiece zero. You can determine the workpiece zero on the following workpiece elements:

- Edges, (Page 89)
- Corner (Page 91)
- Pocket and hole (Page 95)
- Spigot (Page 101)

Measuring methods

You can measure the workpiece zero either manually or automatically.

Manual measurement

To measure the zero point manually, you need to traverse your tool manually up to the workpiece. You can use edge probes, sensing probes, or dial gauges with known radii and lengths. You can also use any other tool of which you know the radius and length.

The tools used for measuring must not be electronic probes.

Automatic measurement

For automatic measurements, only use the electronic workpiece probe, tool type 710/712. You must first calibrate the electronic workpiece probe.

In the case of automatic measuring, first position the workpiece probe manually. After starting using the <CYCLE START> key, the workpiece probe is automatically extended to the workpiece with the measuring feedrate. Retraction motion from the measuring point is realized as a function of the setting data with the rapid traverse velocity or a user-specific positioning velocity.

Measuring with rotation

Under the function "Measuring with rotation" you have the option to measure without prior calibration and without entry of a calibration dataset to be used.

To do this, you will need a positionable spindle as well as an electronic 3D workpiece probe. The radius of the probe ball of the electrical probe must be determined once by calibration and entered in the tool data.

Spindle orientation of the probe in the measuring direction

In order to obtain extremely precise measurement results, you have the option to orientate the electronic 3D probe in the measuring direction to avoid deviations regarding the rotation-symmetric shifting characteristics. Orienting the probe is performed by positioning the working spindle into which the probe is clamped.

To do this, you will need a positionable spindle as well as an electronic 3D workpiece probe.

Probe in a machining spindle that cannot be positioned or fixed at the machine

Also at machines without SPOS-capable spindle, you have the possibility of measuring workpieces using electronic probes.

To do this, you will need a 3D probe (multi probe type 710). This measurement method requires that the measuring task does not require that the spindle is positioned.

Adapting the user interface to calibrating and measuring functions

Activate the following selection options using setting data:

- Calibration plane, measurement plane
- Calibration feedrate (measuring feedrate)
- Work offset as basis for the measuring process
- Number of the probe calibration data set
- Offset target, adjustable work offset
- Offset target, basis reference
- Offset target, global basis work offset
- Offset target, channel-specific basis work offset
- Standard measuring method
- Measuring with spindle reversal
- Align probe
- The measurement method depends on the probe



Machine manufacturer

Please refer to the machine manufacturer's specifications.

Note

"Measuring only" for automatic measuring

If "Measuring only" is selected as offset target, then instead of the "Set WO" softkey, the "Calculate" softkey is displayed.

The measuring versions "Set edge", "Rectangular pocket", "Rectangular spigot", "1 circular spigot" and "1 hole" are an exception. For these single-point measurements, for "Measuring only" neither the "Set WO" softkey nor the "Calculate" softkey is listed.

Preconditions

- The automatic measurement in the JOG mode is completely installed and functional in the default setting of the control.
- When tool type 710/712 is active, the automatic measuring functions are always executed in the JOG mode.
- You specify user-specific settings (e.g. positioning velocity in the working plane or tool axis, length of the measuring distance) using the appropriate parameters.



Machine manufacturer

Please refer to the machine manufacturer's specifications.

References

Information on user-specific settings is provided in the Chapter "Measuring in the JOG mode".

Commissioning Manual SINUMERIK Operate (IM9) / SINUMERIK 840D sl

Selecting the measuring plane

The measuring plane (G17,18,19) can be selected to flexibly adapt to measuring tasks. If the measuring plane selection is not activated, then the measurement is performed based on the currently active measuring plane.

Selecting the probe number and the calibration data set number

Workpiece probe calibration data fields can be selected using this function. For different measuring situations, in order to guarantee a high measuring accuracy, it may be necessary to save the corresponding calibration data in different data fields, which can then be selected for the measuring tasks.

If the probe number selection is not activated, then probe number "one" is always used.

Entering the calibration feedrate

The actual calibration feedrate can be entered into this entry field. The calibration feedrate is stored in the calibration data and is used for the measurements.

If the entry field does not exist, then the calibration feedrate from a central parameter is used.

Selecting the work offset as basis for the measurement

A work offset can be selected as measurement basis to flexibly adapt to the measuring tasks.

If the work offset selection as measurement basis is not activated, then the measurement refers to the currently active work offset.

Measuring sequence

To obtain the desired measuring results, you must keep to the measuring point sequence shown in the help displays.

You can reject measuring points and then measure them again. This is done by pressing the softkey that is currently active (measured value).

Measuring only

If you "only" want to measure the workpiece zero, the measured values are calculated and displayed without changing the coordinate system.

Work offset

You usually store the measured workpiece zero in a work offset. The HMI allows rotations and offsets to be measured.

Zero point

The measurement values for the offsets are stored in the coarse offset and the relevant fine offsets are deleted. If the zero point is stored in a non-active work offset, an activation window is displayed in which you can activate this work offset directly.



Machine manufacturer

Please refer to the machine manufacturer's specifications.

Aligning

Alignment can be performed either by rotating the coordinate system or by rotating the workpiece with a rotary axis. If your machine is equipped with two rotary axes and the "swivel" function is set up, you can also align an inclined plane.

Rotary axes

If your machine has rotary axes, you can include these rotary axes in the measurement and setup procedure. If you store the workpiece zero in a work offset, rotary axis positioning may be necessary in the following cases.

- Correcting the work offset requires you to position the rotary axes to align the workpiece parallel with the coordinate system, e.g. with "Align edge".
- Correcting the work offset rotates the workpiece coordinate system, which should align the tool perpendicular to the plane, e.g. for "Align plane".

You are supported by one or two activation windows when you position the rotary axes (see Corrections after measuring the zero point (Page 111)).

You can only select "Rotary axis <name of rotary axis>" for the "Angle corr." parameter, if your machine has rotary axes.

They must also be assigned to geometry axes via the machine data.



Machine manufacturer

Please refer to the machine manufacturer's specifications.

2.6.2 Sequence of operations

To measure the workpiece zero, the workpiece probe must always be located or set perpendicular to the measuring plane (machining plane) (e.g. using "Align plane").

For the measuring versions "Set edge", "Distance 2 edges", "Rectangular pocket" and "Rectangular spigot", the workpiece must first be aligned parallel to the coordinate system.

To do this, it may be necessary to perform the measuring process in several steps.

Possible step sequences

1. "Align plane" (to align the workpiece probe perpendicular to the plane)
2. "Align edge" (to align the workpiece parallel to the coordinate system)
3. "Set edge" or "Distance 2 edges" or "Rectangular pocket" or "Rectangular spigot", to define the workpiece zero.

- OR -

1. "Align plane" (to align the workpiece probe perpendicular to the plane)
2. "Corner" or "2 holes" or "2 spigots", to align the the coordinate system parallel to the workpiece and to determine the workpiece zero)

Pre-positioning

If you want to preposition a rotary axis before measuring with "Align edge", move the rotary axis so that your workpiece is approximately parallel to the coordinate system.

Set the relevant rotary axis angle to zero with "Set WO". Measurement with "Align edge" will then correct the value for rotary axis offset or include it in the coordinate rotation and align the workpiece edge precisely.

If you want to preposition your workpiece with "Align plane" prior to measurement, you can set the required angular values under "Manual swivel". With "Set zero plane" you transfer the resulting rotations into the active work offset.

The measurement with "Align plane" will then correct the value for the coordinate rotations and precisely align the workpiece.

If the function "Swivel Manual" is set up on your machine, we recommend that you perform swivel to zero before starting measurement. In that way, you will ensure that the rotary axis positions match the actual coordinate system.

2.6.3 Examples with manual swivel

Two typical examples demonstrate the interaction and the use of "Measure workpiece" and "Manual swivel" when measuring and aligning workpieces.

First example

The following steps are required when remachining a cylinder head with 2 holes on an inclined plane.

1. Clamp the workpiece
2. T,S,M
Load the probe and activate the desired work offset.
3. Pre-position the workpiece
Manually rotate the rotary axes until the inclined surface is almost perpendicular to the tool axis.
4. Manual swivel
Select "direct" swivel, press the "Teach rotary axes" softkey and press <CYCLE START> key.
5. Manual swivel
Apply "Set zero plane" to store the resulting rotations in the work zero.
6. Measure workpiece
Apply "Align plane" to correct the alignment of the workpiece.
7. Measure workpiece
Apply "2 holes" to define the rotation and offset in the XY plane.
8. Measure workpiece
Apply "Set edge Z" to define the offset in Z.
9. Start part program to remachine under AUTO.
Start the program with swivel zero.

Second example

Measuring workpieces in swiveled states. The workpiece is to be probed in the X direction even though the probe cannot approach the workpiece in the X direction because of an obstructing edge (e.g. due to clamping elements). However, with a swivel movement, the measurement in the X direction can be replaced by a measurement in the Z direction.

1. Clamp the workpiece.

2. T,S,M

Load the probe and activate the desired work offset.

3. Manual swivel

With "direct" swiveling enter the required rotary axis positions or with "axis by axis" the required rotations (e.g. Y=-90) and <CYCLE START>.

4. Measure workpiece

Apply "Set edge Z": The measured offset in Z is converted and entered as an X value in the chosen work offset.

2.6.4 Calibrating the electronic workpiece probe

When the electronic probes are attached to the spindle, clamping tolerances usually occur. This can lead to measurement errors.

In addition, you need to determine the trigger points of the probe relative to the spindle center (trigger points).

Therefore, you need to calibrate the electronic probe. The radius is calibrated in a setting ring (calibration ring) or a hole, the length is calibrated on a surface. The diameter of the setting ring and the dimension of the surface in the Z direction (for G17) must be precisely known and this is entered into the corresponding entry field when calibrating the probe. The diameter of the workpiece probe ball and its length 1 must be stored in the tool list.

Procedure

1. Load the workpiece probe into the spindle.
2. Enter the approximate length and radius in the tool data.

Calibrating a radius

3. Move the workpiece probe into the hole and position it in the approximate center of the hole.
4. Select the "JOG" mode in the "Machine" operating area.





5. Press the "Workpiece zero" and "Probe calibration" softkeys.
The window "Calibration: Probe" is opened.

6. Press the "Radius" softkey.

7. In \varnothing , enter the calibration bore corresponding to the diameter.

8. Press the <CYCLE START> key.

The calibration starts.

When calibrating the radius, the exact hole center point is determined first. Then the four trigger points on the inside wall of the hole are approached.

This procedure is carried out automatically twice: First with 180° (to the starting position of the working spindle) and then in its starting position.

Calibrating a length

9. Move the workpiece probe over the surface.

10. Select operating mode "JOG" in the "Machine operating area" and press the "Workpiece zero" and "Probe calibration" softkeys.

The "Calibrate Probe" window opens.



11. Press the "Length" softkey.

12. Specify reference point Z0 of the surface, e.g. of the workpiece or the machine table.

13. Press the <CYCLE START> key.

The calibration starts.

When the length is calibrated, the length of the workpiece probe is calculated and entered in the tool list.



Note

User-specific defaults

- "Setting ring diameter"
For the entry field "Diameter setting ring" (diameter, reference piece), fixed values can be separately entered at parameters for each probe number (calibration data set number). If these parameters are assigned, the values saved there are displayed in the entry field "Diameter setting ring"; however, they can no longer be changed there.
- "Height of the reference surface in the infeed axis"
For the entry field "Height of the reference surface" fixed values can be separately entered at parameters for each probe number (calibration data set number). If these parameters are assigned, the values saved there are displayed in the entry field "Height of the reference surface"; however, they can no longer be changed there.

Please refer to the machine manufacturer's specifications.

2.6.5 Setting the edge

The workpiece lies parallel to the coordinate system on the work table. You measure one reference point in one of the axes (X, Y, Z).

Requirement

You can insert any tool in the spindle for scratching when measuring the workpiece zero manually.

- OR -

An electronic workpiece probe is inserted in the spindle and activated when measuring the workpiece zero automatically.

Procedure



1. Select the "Machine" operating area and press the <JOG> key.



2.6 Measuring the workpiece zero



- 2. Press the "Workpiece zero" and "Set edge" softkeys.
The "Set Edge" window opens.

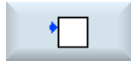

- 3. Select "Measuring only" if you only want to display the measured values.

- OR -



- 4. In the selection box, select the desired zero offset in which you want to store the zero point.

- OR -



Press the "Select ZO" softkey to select an settable zero offset.



In the window "Zero Offset – G54 ... G599", select a zero offset, in which the zero point should be saved and press the "In manual" softkey.

You return to the measurement window.



- 5. Use the softkeys to select in which axis direction you want to approach the workpiece first.

...

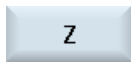

- 6. Select the measuring direction (+ or -) you want to approach the workpiece in.

For Z0, the workpiece is always approached in the Z minus direction.

- 7. In X0, Y0, or Z0, specify the setpoint position of the workpiece edge.
The setpoint position corresponds, e.g. to the dimension specifications of the workpiece edge from the workpiece drawing.



- 8. Traverse the workpiece probe close to the workpiece edge that you wish to measure and press the <CYCLE START> key in order to measure the workpiece zero automatically.

Note

Settable zero offsets

The labeling of the softkeys for the settable zero offsets varies, i.e. the settable zero offsets configured on the machine are displayed (examples: G54...G57, G54...G505, G54...G599).

Please refer to the machine manufacturer's specifications.

2.6.6 Edge measurement

The following options are available to you when measuring an edge:

Aligning the edge

The workpiece lies in any direction, i.e. not parallel to the coordinate system on the work table. By measuring two points on the workpiece reference edge that you have selected, you determine the angle to the coordinate system.

Distance between 2 edges

The workpiece lies parallel to the coordinate system on the work table. You measure distance L of two parallel workpiece edges in one of the axes (X, Y, or Z) and determine its center.

Requirement

You can insert any tool in the spindle for scratching when measuring the workpiece zero manually.

- OR -

An electronic workpiece probe is inserted in the spindle and activated when measuring the workpiece zero automatically.

Procedure



1. Select the "Machine" operating area and press the <JOG> key.



2. Press the "Workpiece zero" softkey.



3. Press the "Align edge" softkey.

- OR -

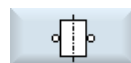

Press the "Distance between 2 edges" softkey.

- OR -



If these softkeys are not listed, press any vertical softkey (with the exception of "Set edge") and in the drop-down list, select the desired measurement version.

2.6 Measuring the workpiece zero



4. Select "Measuring only" if you only want to display the measured values.

- OR -



5. In the selection box, select the desired zero offset in which you want to store the zero point.

- OR -



Press the "Select ZO" softkey to select an settable zero offset.



In the window "Zero Offset – G54 ... G599", select a zero offset, in which the zero point should be saved and press the "In manual" softkey.



You return to the measurement window.



6. Under "Measuring axis", select the axis in which you want to approach the workpiece, and the measuring direction (+ or -).

7. Enter the setpoint angle between the workpiece edge and the reference axis.

8. Traverse the tool to the workpiece edge.



9. Press the "Save P1" softkey.



10. Reposition the tool and repeat the measuring procedure (step 7) to measure the second point, and then press the "Save P2" softkey.



11. Press the "Calculate" softkey.

The angle between the workpiece edge and reference axis is calculated and displayed.

- OR -



Press the "Set ZO" softkey.

With "Set ZO", the workpiece edge now corresponds to the setpoint angle.

The calculated rotation is stored in the zero offset.





Note

Settable zero offsets

The labeling of the softkeys for the settable zero offsets varies, i.e. the settable zero offsets configured on the machine are displayed (examples: G54...G57, G54...G505, G54...G599).

Please refer to the machine manufacturer's specifications.

Automatic measurement

1. Prepare the measurement (see steps 1 to 5 above).
2. Traverse the workpiece probe close to the workpiece edge on which you wish to measure and press the <CYCLE START> key.
 This starts the automatic measuring process. The position of measuring point 1 is measured and stored.
The "P1 stored" softkey becomes active.
3. Repeat the operation to measure and store P2.

4. Press the "Calculate" softkey.
 The angle between the workpiece edge and reference axis is calculated and displayed.
- OR -
Press the "Set ZO" softkey.
 With "Set ZO", the workpiece edge now corresponds to the setpoint angle.
The calculated rotation is stored in the correction target that you have selected.

2.6.7 Measuring a corner

You have the option to measure workpiece corners, which are defined by a right angle (90°) or any inner angle.

Measuring a right-angled corner

The workpiece corner to be measured has a 90° inner angle and is clamped to the worktable in any position. By measuring 3 points you can determine the corner point (point of intersection of the angle side) in the working plane and angle α between the workpiece reference edge (line through P1 and P2) and the reference axis in the working plane (1st geometry axis of the working plane).

Measuring any corner

The workpiece corner to be measured has any (not right-angled) inner angle and is clamped at any position on the worktable. By measuring four points you can determine the corner point (point of intersection of the angle sides) in the working plane and angle α between the workpiece reference edge (line through P1 and P2) and the reference axis in the working plane (1st geometry axis of the working plane) and inner angle β of the corner.

Note

The coordinate system shown in the help displays is always in relation to the currently set workpiece coordinate system.

Please be aware of this if you have swiveled or changed the WCS in any other form.

Requirement

You can insert any tool in the spindle for scratching when measuring the workpiece zero manually.

- OR -

An electronic workpiece probe is inserted in the spindle and activated when measuring the workpiece zero automatically.

Procedure



1. Select the "Machine" operating area and press the <JOG> key.



2. Press the "Workpiece zero" softkey.



3. Press the "Right-angled corner" softkey if the workpiece has a right-angled corner.

- OR -



Press the "Any corner" softkey, if you want to measure a corner not equal to 90°.

- OR -



If these softkeys are not listed, press any vertical softkey (with the exception of "Set edge") and in the drop-down list, select the desired measurement version.



4. Select "Measuring only" if you only want to display the measured values.

- OR -



5. In the selection box, select the desired zero offset in which you want to store the zero point.

- OR -



Press the "Select ZO" softkey to select a settable zero offset.



In the window "Zero Offset – G54 ... G599", select a zero offset, in which the zero point should be saved and press the "In manual" softkey.



You return to the measurement window.



6. Select the corner (inside corner or outside corner) that you wish to measure and its position (position 1... position 4).

The position of the measuring points appear in the help display.

7. Specify the setpoint of the workpiece corner (Z0, X0) you want to measure.

8. Traverse the tool (acc. to help display) to the first measuring point P1 if you are measuring manually.



9. Press the "Save P1" softkey.

The coordinates of the first measuring point are measured and stored.



10. Reposition the spindle holding the tool each time, approach measuring points P2 and P3 and press the "Save P2" and "Save P3" softkeys.



11. Repeat the procedure to measure the fourth measuring point when you measure any corner.



12. Press the "Calculate" softkey.

The corner point and angle α are calculated and displayed.

- OR -



13. Press the "Set ZO" softkey.

The corner point now corresponds to the setpoint position. The calculated offset is stored in the zero offset.

Note

Settable zero offsets

The labeling of the softkeys for the settable zero offsets varies, i.e. the settable zero offsets configured on the machine are displayed (examples: G54...G57, G54...G505, G54...G599).

Please refer to the machine manufacturer's specifications.

Automatic measurement



1. Prepare the measurement (see steps 1 to 6 above).
2. Approach measuring point P1 with the workpiece probe and press the <CYCLE START> key.

This starts the automatic measuring process. The position of measuring point 1 is measured and stored.

The "P1 stored" softkey becomes active.



3. Repeat the operation to measure and store points P2 and P3.

If you are measuring a corner not equal to 90°, repeat the procedure to measure and store point P4.



4. Press the "Calculate" softkey.

The corner point and angle α are calculated and displayed.

- OR -

Press the "Set ZO" softkey.



The corner point now corresponds to the setpoint position. The calculated offset is stored in the offset target that you have selected.

2.6.8 Measuring a pocket and hole

You can measure rectangular pockets and one or more holes and then align the workpiece.

Measuring a rectangular pocket

The rectangular pocket must be aligned at right-angles to the coordinate system. By automatically measuring four points inside the pocket, its length, width and center point can be determined.

Measuring one hole

The workpiece with the hole to be measured is clamped to the work table in any position. In the hole, four points are automatically measured, and from this measurement, the diameter and center point of the hole are determined.

Measuring two holes

The workpiece with the two holes to be measured is clamped to the work table in any position. Four points are automatically measured in both holes and the hole centers are calculated from them. Angle α is calculated from the connecting line between both center points and the reference axis, and the new zero point that corresponds to the center point of the 1st hole is determined.

Measuring three holes

The workpiece with the three holes to be measured is clamped to the work table in any position. Four points are automatically measured in the three holes and the hole centers are calculated from them. A circle is placed through the three center points. The center point and the diameter are determined from this circle. This center point represents the new workpiece zero to be determined. When an angular offset is selected, the base angle of rotation α can also be determined.

Measuring four holes

The workpiece with the four holes to be measured is clamped to the work table in any position. Four points are automatically measured in the four holes and the hole centers are calculated from them. Two hole center points are diagonally connected in each case. The point of intersection is determined from the two lines that are obtained. This point of intersection represents the new workpiece zero to be determined. When an angular offset is selected, the base angle of rotation α can also be determined.

Note

"Measuring only" for automatic measuring

If "Measuring only" is selected as offset target, then instead of the "Set ZO" softkey, the "Calculate" softkey is displayed.

The measuring versions "Rectangular pocket" and "1 hole" are an exception. For these single-point measurements, for "Measuring only" neither the "Set ZO" softkey nor the "Calculate" softkey is listed.

Note

You can only measure 2, 3, and 4 holes automatically.

Requirement

You can insert any tool in the spindle for scratching when measuring the workpiece zero manually.

- OR -

An electronic workpiece probe is inserted in the spindle and activated when measuring the workpiece zero automatically.

Procedure



1. Select the "Machine" operating area and press the <JOG> key.



2. Press the "Workpiece zero" softkey.



3. Press the "Rectangular pocket" softkey.

- OR -



Press the "1 hole" softkey.

- OR -



If these softkeys are not listed, press any vertical softkey (with the exception of "Set edge") and in the drop-down list, select the desired measurement version.



4. Select "Measuring only" if you only want to display the measured values.

- OR -



5. In the selection box, select the desired zero offset in which you want to store the zero point.

- OR -



Press the "Select ZO" softkey to select an settable zero offset.



In the window "Zero Offset – G54 ... G599", select a zero offset, in which the zero point should be saved and press the "In manual" softkey.

You return to the measurement window.



6. Specify the position setpoints (X0/Y0) of the pocket center point or hole center point.

7. Traverse the tool to the first/next measuring point if you are measuring manually.



8. Press the "Save P1" softkey.

The point is measured and stored.



9. Repeat steps 6 and 7 to measure and store measuring points P2, P3 and P4.

...

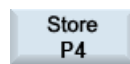

10. Press the "Calculate" softkey.

The length, width, and center point of the rectangular pocket or diameter and center point of the hole are calculated and displayed.

- OR -



Press the "Set ZO" softkey.

The setpoint position of the center point is stored as a new zero point with "Set ZO". The tool radius is automatically included in the calculation.

Note

Settable zero offsets

The labeling of the softkeys for the settable zero offsets varies, i.e. the settable zero offsets configured on the machine are displayed (examples: G54...G57, G54...G505, G54...G599).

Please refer to the machine manufacturer's specifications.

Automatic measurement



1. Select the "Measure workpiece zero" function (see steps 1 and 2 above).
2. Press the "Rectangular pocket" softkey.

- OR -

Press the "1 hole" softkey.

- OR -

Press the "2 holes" softkey.

- OR -

Press the "3 holes" softkey.

- OR -

Press the "4 holes" softkey.

- OR -

If these softkeys are not listed, press any vertical softkey (with the exception of "Set edge") and in the drop-down list, select the desired measurement version.

3. Traverse the workpiece probe to approximately the center above the rectangular pocket or the hole or for several, above the first hole to be measured.
4. Specify whether you want "Measurement only" or in which zero offset you want to store the zero point.

Rectangular pocket

5.
 - If you do make any entry in the entry field "L" length (1st geometry axis of the working plane) or "W" width (2nd geometry axis of the working plane) of the pocket, then the axis moves with the measuring feedrate from the starting point.
If the measuring stroke does not reach the edge, then this data must be approximately entered. However, the measuring sequence is then also shortened as part of the measuring distance is moved with rapid traverse.

- OR -

- 1 hole**
- If you do not make any entry in the entry field "Øhole", then the axis moves with the measuring feedrate from the starting point. If the measuring stroke does not reach the edge of the hole, then the approximate diameter must be entered. However, the measuring sequence is then also shortened as part of the measuring distance is moved with rapid traverse.
 - Enter an angle in "Probe angle". With the probe angle you can turn the traversing direction of the probe through any angle.
- OR -
- 2 holes**
- If you do not make any entry in the entry field "Øhole", then the axis moves with the measuring feed from the starting point. If the measuring stroke does not reach the edge of the hole, then the approximate diameter must be entered. However, the measuring sequence is then also shortened as part of the measuring distance is moved with rapid traverse.
 - In "Angle offs.", select entry "Coord. rotation".
- OR -
- In "Angle offs.", select the "Rotary axis A, B, C" entry.
- Enter the setpoint angle.
 - Specify the position setpoints (X1/Y1) for the center point of the first hole.
- X1 and Y1 are only active, if the "Coor. rotation" entry is selected.
- OR -
- 3 holes**
- If you do not make any entry in the entry field "Øhole", then the axis moves with the measuring feed from the starting point. If the measuring stroke does not reach the edge of the hole, then the approximate diameter must be entered. However, the measuring sequence is then also shortened as part of the measuring distance is moved with rapid traverse.
 - In "Angle offs." select entry "No".
- OR -
- In "Angle offs." select entry "Yes" if you want alignment to be performed with coordinate rotation.
- Enter the setpoint angle.
- The angle entered here refers to the 1st axis of the working plane (X/Y plane). This input field only appears if you specified "Yes" for "Angle offs."
- Specify setpoint positions X0 and Y0.
- These determine the center point of the circle on which the center points of the three holes are to lie.
- OR -

4 holes

- If you do not make any entry in the entry field "Øhole", then the axis moves with the measuring feed from the starting point. If the measuring stroke does not reach the edge of the hole, then the approximate diameter must be entered. However, the measuring sequence is then also shortened as part of the measuring distance is moved with rapid traverse.
- In "Angle offs." select entry "No".
- OR -
- In "Angle offs." select entry "Yes" if you want alignment to be performed with coordinate rotation.
- Enter the setpoint angle.
The angle entered here refers to the 1st axis of the working plane (X/Y plane). This input field only appears if you specified "Yes" for "Angle offs."
- Specify setpoint positions X0 and Y0.

These determine the point of intersection of the lines connecting the hole center points.



7. Press the <CYCLE START> key.

The tool automatically probes four points of the inner sides of the pocket or hole in succession.

After the measurement has been successfully completed, the "P1 stored" softkey becomes active.



8. Then move the tool approximately to the center of the second, third, and fourth hole and press the <CYCLE START> key.

After measuring points P2, P3, and P4 have been successfully measured, the "P2 stored", "P3 stored", and "P4 stored" softkeys become active.



9. Press the "Calculate" or "Set ZO" softkey.



Rectangular pocket

The length, width, and center point of the rectangular pocket are calculated and displayed.

For "Set ZO", the setpoint position of the center point is stored as new zero point.

1 hole

The diameter and center point of the hole are calculated and displayed.

The tool automatically probes four points of the inside wall of the hole one after the other and the setpoint position of the center point is stored as the new zero point.

2 holes	<p>The tool automatically probes four points of the inside wall of the first hole successively and after pressing <CYCLE START> again probes the four points of the inside wall of the second hole.</p> <p>The angle between the line connecting the center points and the reference axis is calculated and displayed.</p> <p>With "Set ZO", the center point of the first hole now corresponds to the position setpoint. The calculated rotation is stored in the zero offset.</p>
3 holes	<p>The tool automatically probes four points of the inside wall of the first hole successively and after pressing <CYCLE START> again, then the four points of the inside wall of the second or third hole are successively probed.</p> <p>The center point and the diameter of the circle on which the three hole center points lie are calculated and displayed. If you selected entry "Yes" for "Angle offs.", the angle α is additionally calculated and displayed.</p> <p>With "Set ZO", the center point of the first hole now corresponds to the position setpoint. The calculated rotation is stored in the zero offset.</p>
4 holes	<p>The tool automatically probes four points of the inside wall of the first hole successively. After pressing <CYCLE START> again, the tool automatically probes the four points of the inside wall of the second, third and fourth holes.</p> <p>The hole center points are connected diagonally and the intersection point of the two connecting lines calculated and displayed. If you selected entry "Yes" for "Angle offs.", the angle α is additionally calculated and displayed.</p> <p>With "Set ZO", the intersection point now corresponds to the position setpoint. The calculated rotation is stored in the zero offset.</p>

2.6.9 Measuring a spigot

You have the option to measure and align rectangular spigots, and one or more circular spigots.

Measuring a rectangular spigot

The rectangular spigot should be aligned at right-angles to the coordinate system. By measuring four points at the spigot you can determine the length, width, and center point of the spigot.

Please note that the straight lines between points P1 and P2 or P3 and P4 must intersect with one another, in order that a measurement result is displayed.

Measuring one circular spigot

The workpiece is located anywhere on the work table and has a circular spigot. You can determine the diameter and center point of the spigot with four measuring points.

Measuring two circular spigots

The workpiece is located anywhere on the work table and has 2 spigots. Four points are automatically measured at the two spigots and the spigot centers are calculated from them. The angle α is calculated from the connecting line between both center points and the reference axis, and the new zero point that corresponds to the center point of the first spigot is determined.

Measuring three circular spigots

The workpiece is located anywhere on the work table and has three spigots. Four points are automatically measured at the three spigots and the spigot centers are calculated from them. A circle is placed through the three center points and the circle center and circle diameter are determined.

When an angular offset is selected, the base angle of rotation α can also be determined.

Measuring four circular spigots

The workpiece is located anywhere on the work table and has four spigots. four points are automatically measured at the four spigots and the spigot centers are calculated from them. Two spigot center points are each connected diagonally and the intersection point of the two lines is then determined. When an angular offset is selected, the base angle of rotation α can also be determined.

Note

"Measuring only" for automatic measuring

If "Measuring only" is selected as offset target, then instead of the "Set ZO" softkey, the "Calculate" softkey is displayed.

The measuring versions "Rectangular spigot" and "1 circular spigot" are an exception. For these single-point measurements, for "Measuring only" neither the "Set ZO" softkey nor the "Calculate" softkey is listed.

Note

You can only measure 2, 3, and 4 circular spigots automatically.

Requirement

You can insert any tool in the spindle for scratching when measuring the workpiece zero manually.

An electronic workpiece probe is inserted in the spindle and activated when measuring the workpiece zero automatically.

Procedure



1. Select the "Machine" operating area and press the <JOG> key.



2. Press the "Workpiece zero" softkey.

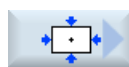

3. Press the "Rectangular spigot" softkey.

- OR -

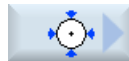

Press the "1 circular spigot" softkey.

- OR -



If these softkeys are not listed, press any vertical softkey (with the exception of "Set edge") and in the drop-down list, select the desired measurement version.



4. Select "Measuring only" if you only want to display the measured values.

- OR -



Select the desired zero offset in which you want to store the zero point (e.g. basis reference).

- OR -



Press the "Select ZO" softkey and select the zero offset in which the zero point is to be saved in the "Zero Offset – G54 ... G599" window and press the "In manual" softkey.



You return to the "1 Circular Spigot" window.

The selection of zero offsets can differ.



Please refer to the machine manufacturer's specifications.







5. Specify the position setpoints (X0/Y0) of the spigot center point P0.

6. Traverse the tool to the first measuring point.

7. Press the "Save P1" softkey.

The point is measured and stored.

2.6 Measuring the workpiece zero

-  8. Repeat steps 6 and 7 to measure and store measuring points P2, P3 and P4.
- 
-  9. Press the "Calculate" softkey.
The diameter and center point of the spigot are calculated and displayed.
- OR -
-  Press the "Set ZO" softkey.
The setpoint position of the center point is stored as a new zero point with "Set ZO". The tool radius is automatically included in the calculation.





Note

Settable zero offsets

The labeling of the softkeys for the settable zero offsets varies, i.e. the settable zero offsets configured on the machine are displayed (examples: G54...G57, G54...G505, G54...G599).

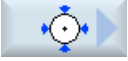
Please refer to the machine manufacturer's specifications.

Automatic measurement

- 1. Select the "Measure workpiece zero" function (see steps 1 and 2 above).
-  2. Press the "Rectangular spigot" softkey.
- OR -
-  Press the "1 circular spigot" softkey.
- OR -
-  Press the "2 circular spigots" softkey.
- OR -
-  Press the "3 circular spigots" softkey.
- OR -
-  Press the "4 circular spigots" softkey.
- OR -



If these softkeys are not listed, press any vertical softkey (with the exception of "Set edge") and in the drop-down list, select the desired measurement version.

3. Traverse the workpiece probe to approximately the center above the rectangular or circular spigot, or for several, above the first spigot to be measured.

4. Specify whether you want "Measurement only" or in which zero offset you want to store the zero point.

**Rectangular
spigot**

5.

- Enter the infeed value in "DY" to determine the measuring depth.
- In field "L" enter the length (1st geometry axis of the working plane) and in field "W" the width (2nd geometry axis of the working plane) of the spigot.

- OR -

**1 circular
spigot**

- Enter the approximate diameter of the spigot into "Øspigot".
- Enter an angle in "Probe angle". With the probe angle you can turn the traversing direction of the probe through any angle.

- OR -

**2 circular
spigots**

- Enter the approximate diameter of the spigot into "Øspigot".
- Enter the infeed value in "DY" to determine the measuring depth.
- In "Angle offs.", select entry "Coor. rotation" or "Rotary axis A, B, C".
- Enter the setpoint angle.
- Enter the position setpoints (Z0/X0) for the center point of the first spigot.

The setpoint angle refers to the 1st axis of the working plane (X/Y plane).

The input fields for the setpoint positions are only active if you selected the angle offset via coordinate rotation.

- OR -

3 circular spigots

- Enter the approximate diameter of the spigot into "Øspigot".
- Enter the infeed value in "DY" to determine the measuring depth.
- In "Angle offs.", select entry "No", or in "Angle offs." select entry "Yes" if you want to align using coordinate rotation.
- Specify the setpoint angle if you selected entry "Yes" for "Angle offs."
- Enter the setpoint positions Z0 and X0 to determine the center point of the circuit on which the center points of three spigots lie.

The setpoint angle refers to the 1st axis of the working plane (X/Y plane). This input field only appears if you specified "Yes" for "Angle offs."

- OR -

4 circular spigots

- Enter the approximate diameter of the spigot into "Øspigot".
- Enter the infeed value in "DZ" to determine the measuring depth.
- In "Angle offs.", select entry "Yes" if you want to align using coordinate rotation or select in "Angle offs." the entry "No".
- Enter the setpoint angle.
- Enter the setpoint positions X0 and Y0 to determine the point of intersection of the connecting lines between the spigot center points.

The setpoint angle refers to the 1st axis of the working plane (X/Y plane). This input field only appears if you specified "Yes" for "Angle offs."



4. Press the <CYCLE START> key.

This starts the automatic measuring process. The tool automatically probes four points in succession of the rectangular or spigot outer wall or the outer wall of the first spigot if several spigots are to be measured. After the measurement has been successfully completed, the center of the spigot is determined and the "P1 stored" softkey becomes active.



5. If you are measuring several spigots, then move the tool approximately to the center of the second, third, and fourth spigot and press the <CYCLE START> key.



...



After the measurement has been successfully completed, P2, P3 and P4 are stored and the softkeys "P2 stored", "P3 stored", and "P4 stored" become active.

6. Press the or "Calculate" or "Set ZO" softkey.

Rectangular spigot

The length, width, and center point of the rectangular spigot are calculated and displayed.

For "Set ZO", the setpoint position of the center point is stored as new zero point. The tool radius is automatically included in the calculation.

1 spigot

The diameter and center point of the spigot are calculated and displayed.

For "Set ZO", the setpoint position of the center point is stored as new zero point. The tool radius is automatically included in the calculation.

2 spigots

The angle between the line connecting the center points and the reference axis is calculated and displayed.

For "Set ZO", the center point of the first spigot now corresponds to the position setpoint. The calculated rotation is stored in the zero offset.

3 spigots

The center point and the diameter of the circle on which the three spigot center points lie are calculated and displayed. If you selected entry "Yes" in "Coor. rotation", then angle α is additionally calculated and displayed.

For "Set ZO", the center point of the circle now corresponds to the position setpoint. The calculated rotation is stored in the zero offset.

4 spigots

The spigot center points are connected diagonally and the intersection point of the two connecting lines calculated and displayed. If you selected entry "Yes" in "Coor. rotation", then angle α is additionally calculated and displayed.

For "Set ZO", the intersection point now corresponds to the position setpoint. The calculated rotation is stored in the zero offset.

2.6.10 Aligning the plane

You can measure an inclined plane of a workpiece in space and determine rotation angles α and β . By subsequently performing coordinate rotation, you can align the tool axis perpendicular to the workpiece plane.

In order to determine the position of the plane in space, three different points are measured along the tool axis. To vertically align the tool axis, the "Swivel" function or the 5 axis transformation (TRAORI) must be set-up at the machine.

In order to be able to measure the plane, the surface must be flat.

Requirement

You can insert any tool in the spindle for scratching when measuring the workpiece zero manually.

An electronic workpiece probe is inserted in the spindle and activated when measuring the workpiece zero automatically.

Procedure



1. Select the "Machine" operating area and press the <JOG> key.



2. Press the "Workpiece zero" and "Align plane" softkeys. The "Align plane" window opens.



3. Select "Measuring only" if you only want to display the measured values.

- OR -



Select the desired zero offset in which you want to store the zero point (e.g. basis reference).

- OR -

Work
offset

G54...
G599

In
manual

Press the "Select ZO" softkey and select the zero offset in which the zero point is to be saved in the "Zero Offset – G54 ... G599" window and press the "In manual" softkey.

You return to the appropriate measurement window.

You return to the "Align plane" window.

The selection of zero offsets can differ.

Please refer to the machine manufacturer's specifications.

4. Traverse the tool to the first measuring point that you want to determine.
5. Press the "Save P1" softkey.
6. Then traverse the tool to the second and third measuring point and press the "Save P2" and "Save P3" softkeys.
7. Press the "Set ZO" or "Calculate" softkey.
Angles α and β are calculated and displayed.
For "Set ZO" the angle offset is stored in the zero offset.

Store
P1

Store
P2

Store
P3

Set
ZO

Calculate

See also

Corrections after measurement of the zero point (Page 111)

2.6.11 Defining the measurement function selection

The measurement versions "Set edge", "Align edge", "Right-angled corner", "1 hole" and "1 circular spigot" are listed in the "Measure workpiece zero" in the associated vertical softkey bar.

You have the option of replacing these by softkeys with other measurement versions.

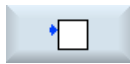

"Set edge" softkey

The "Set edge" softkey cannot be assigned the softkey of another measurement version.



Software option

You require the "Extended operator function" option for the measurement function selection (only for 828D).

Procedure



1. The "Measure workpiece zero" function is selected.



2. Press the softkey that you wish to assign to a new measurement version, e.g. "1 circular spigot".

The "1 Circular Spigot" window opens.



3. Open the list of measurement versions, select the desired measurement version using the <Cursor down> and the <Input> keys.



- OR -



3. Using the <Select> key, in the drop down list box, select the desired measurement version, e.g. "Align plane".

The "Align plane" window opens.

4. Enter the required parameter in order to make the measurement as usual.

- OR -



Press the "Back" softkey.



The selected softkey is assigned the new measurement version, in this case, "Align plane".

2.6.12 Corrections after measurement of the zero point

If you store the workpiece zero in a work offset, changes to the coordinate system or axis positions might be necessary in the following cases.

- Correcting the work offset causes the workpiece coordinate system to rotate, after which the tool can be aligned perpendicularly to the plane.
- Correcting the work offset necessitates positioning of the rotary axis in order to align the workpiece parallel with the coordinate system

Activation windows help you to adapt the coordinate system and the axis positions.

Procedure

Activating work offset

You stored the workpiece zero in a work offset that was not active during measurement.



1. When you press the "Set WO" softkey, the activation window opens asking whether you want to "Activate work offset Gxxx now?".



2. Press the "OK" softkey to activate the corrected work offset.

Aligning and retracting the tool (for aligning the plane)

Rotating the workpiece coordinate system makes it necessary to realign the tool to the plane.

The activation window asking whether you want to "Position measuring probe perpendicular to plane?" is displayed.



1. Select "Yes" if you want to swivel into the plane.

The query "Positioning by swiveling! Retract?" is displayed.



2. Select the retraction method you want to use.



3. Press the <CYCLE START> key.
When the axis has been retracted the tool is realigned with the help of the swivel cycle.
You can now measure again.

Positioning a rotary axis and entering a feedrate

Once you have measured the workpiece zero you must reposition the rotary axis.

Note:

Retract the probe to a safe position before the rotary axis should move. The activation window asking whether you want to "Position rotary axis X to align?" is displayed.



1. Select "Yes" if you want to position the rotary axis.
An input field for the feedrate and the softkey "Rapid traverse" are displayed.



2. Press the "Rapid traverse" softkey to enter the feedrate in rapid traverse.

- OR -

Enter the desired feedrate into input field "F".



3. Press the <CYCLE START> key.
The rotary axis is repositioned.

2.7 Zero offsets

Following reference point approach, the actual value display for the axis coordinates is based on the machine zero (M) of the machine coordinate system (Machine). The program for machining the workpiece, however, is based on the workpiece zero (W) of the workpiece coordinate system (Work). The machine zero and workpiece zero are not necessarily identical. The distance between the machine zero and the workpiece zero depends on the workpiece type and how it is clamped. This zero offset is taken into account during execution of the program and can be a combination of different offsets.

Following reference point approach, the actual value display for the axis coordinates is based on the machine zero of the machine coordinate system (Machine).

The actual value display of the positions can also refer to the SZS coordinate system (settable zero system). The position of the active tool relative to the workpiece zero is displayed.

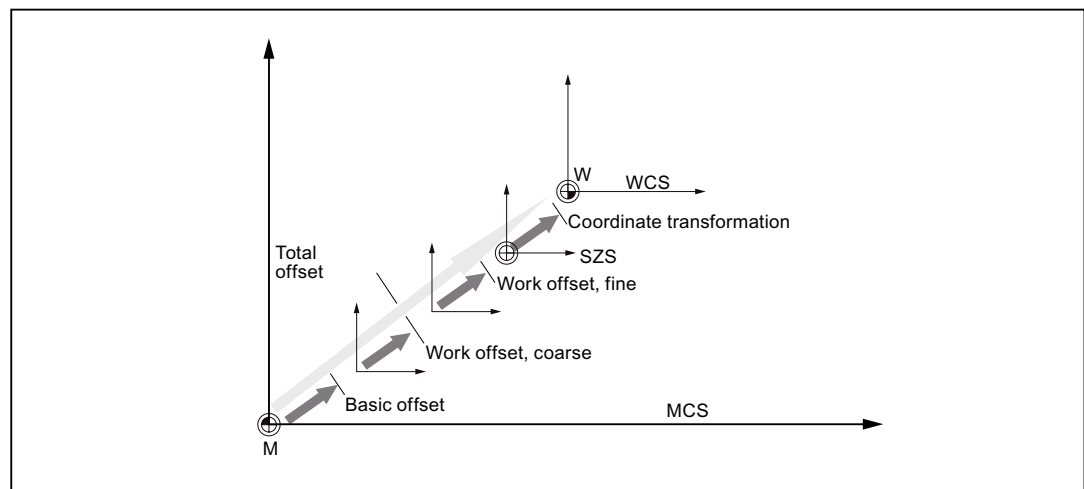

Figure 2-1 Zero offsets

When the machine zero is not identical to the workpiece zero, at least one offset (base offset or zero offset) exists in which the position of the workpiece zero is saved.

Base offset

The base offset is a zero offset that is always active. If you have not defined a base offset, its value will be zero. The base offset is specified in the "Zero Offset - Base" window.

Coarse and fine offsets

Every zero offset (G54 to G57, G505 to G599) consists of a coarse offset and a fine offset. You can call the zero offsets from any program (coarse and fine offsets are added together).

2.7 Zero offsets

You can save the workpiece zero, for example, in the coarse offset, and then store the offset that occurs when a new workpiece is clamped between the old and the new workpiece zero in the fine offset.

Note

Deselect fine offset (only 840D sl)

You have the option of deselecting the fine offset using machine data MD18600 \$MN_MM_FRAME_FINE_TRANS

See also

Actual value window (Page 38)

2.7.1 Display active zero offset

The following zero offsets are displayed in the "Zero Offset - Active" window:

- Zero offsets, for which active offsets are included, or for which values are entered.
- Settable zero offsets
- Total zero offset

This window is generally used only for monitoring.

The availability of the offsets depends on the setting.



Machine manufacturer

Please refer to the machine manufacturer's specifications.

Procedure



1. Select the "Parameter" operating area.

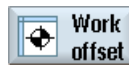

2. Press the "Zero offset" softkey.
The "Zero Offset - Active" window is opened.



Note

Further details on zero offsets

If you would like to see further details about the specified offsets or if you would like to change values for the rotation, scaling or mirroring, press the "Details" softkey.

2.7.2 Displaying the zero offset "overview"

The active offsets or system offsets are displayed for all set-up axes in the "Zero Offset - Overview" window.

In addition to the offset (course and fine), the rotation, scaling and mirroring defined using this are also displayed.

This window is generally used only for monitoring.

Display of active zero offsets

Zero offsets	
DRF	Displays the handwheel axis offset.
Basic reference	Displays the additional zero offsets programmed with \$P_SETFRAME. Access to the system offsets is protected via a keyswitch.
External ZO frame	Displays the additional zero offsets programmed with \$P_EXTFRAME.
Total base ZO	Displays all effective basis offsets.
G500	Displays the zero offsets activated with G54 - G599. Under certain circumstances, you can change the data using "Set ZO", i.e. you can correct a zero point that has been set.

Zero offsets	
Tool reference	Displays the additional zero offsets programmed with \$P_TOOLFRAME.
Workpiece reference	Displays the additional zero offsets programmed with \$P_WPFRAME.
Programmed ZO	Displays the additional zero offsets programmed with \$P_PFRAME.
Cycle reference	Displays the additional zero offsets programmed with \$P_CYCFRAME.
Total ZO	Displays the active zero offset, resulting from the total of all zero offsets.

Procedure

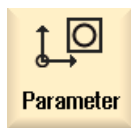

1. Select the "Parameter" operating area.



2. Press the "Zero offset" and "Overview" softkeys.
The "Zero Offsets - Overview" window opens.



2.7.3 Displaying and editing base zero offset

The defined channel-specific and global base offsets, divided into coarse and fine offsets, are displayed for all set-up axes in the "Zero offset - Base" window.



Machine manufacturer

Please refer to the machine manufacturer's specifications.

Procedure

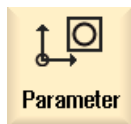

1. Select the "Parameter" operating area.

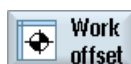

2. Press the "Zero offset" softkey.



3. Press the "Base" softkey.
The "Zero Offset - Base" window is opened.
4. You can edit the values directly in the table.

Note**Activate base offsets**

The offsets specified here are immediately active.

2.7.4 Displaying and editing settable zero offset

All settable offsets, divided into coarse and fine offsets, are displayed in the "Zero Offset - G54..G599" window.

Rotation, scaling and mirroring are displayed.

Procedure

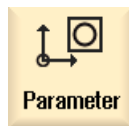

1. Select the "Parameter" operating area.



2. Press the "Zero offset" softkey.

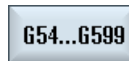

3. Press the "G54...G599" softkey.
The "Zero Offset - G54..G599" window is opened.

Note

The labeling of the softkeys for the settable zero offsets varies, i.e. the settable zero offsets configured on the machine are displayed (examples: G54...G57, G54...G505, G54...G599).

Please observe the machine manufacturer's specifications.

4. You can edit the values directly in the table.

Note**Activate settable zero offsets**

The settable zero offsets must first be selected in the program before they have an impact.

2.7.5 Displaying and editing details of the zero offsets

For each zero offset, you can display and edit all data for all axes. You can also delete zero offsets.

For every axis, values for the following data will be displayed:

- Coarse and fine offsets
- Rotation
- Scaling
- Mirroring



Machine manufacturer

Please refer to the machine manufacturer's specifications.

Note

Settings for rotation, scaling and mirroring are specified here and can only be changed here.

Procedure



1. Select the "Parameter" operating area.

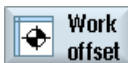

2. Press the "Zero offset" softkey.



3. Press the "Active", "Base" or "G54...G599" softkey.
The corresponding window appears.

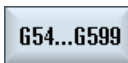

4. Place the cursor on the desired zero offset to view its details.



5. Press the "Details" softkey.

A window opens, depending on the selected zero offset, e.g. "Zero Offset - Details: G54 to G599".

6. You can edit the values directly in the table.

- OR -



Press the "Clear offset" softkey to reset all entered values.



...



Press the "ZO +" or "ZO -" softkey to select the next or previous offset, respectively, within the selected area ("Active", "Base", "G54 to G599") without first having to switch to the overview window.

If you have reached the end of the range (e.g. G599), you will switch automatically to the beginning of the range (e.g. G54).

These value changes are available in the part program immediately or after "Reset".



Machine manufacturer

Please refer to the machine manufacturer's specifications.



Press the "Back" softkey to close the window.

2.7.6 Deleting a zero offset

You have the option of deleting zero offsets. This resets the entered values.

Procedure



1. Select the "Parameter" operating area.

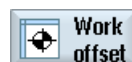

2. Press the "Zero offset" softkey.



3. Press the "Active", "Base" or "G54...G599" softkey.

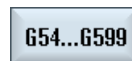

4. Press the "Details" softkey.



5. Position the cursor on the zero offset you would like to delete.
6. Press the "Clear offset" softkey.

2.7.7 Measuring the workpiece zero

Procedure



1. Select the "Parameters" operating area and press the "Zero offset" softkey.

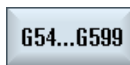

2. Press the "G54...G599" softkey and select the zero offset in which the zero point is to be saved.



3. Press the "Workpiece zero" softkey.



You change to the "Set Edge" window in the "JOG" mode.



4. Use the softkeys to select in which axis direction you want to approach the workpiece first.

...



5. Select the measuring direction (+ or -) you want to approach the workpiece in.
The measuring direction cannot be selected for Z0.
6. In X0, Y0, or Z0, specify the setpoint position of the workpiece edge you are approaching.



Traverse the tool up to the workpiece edge and press the "Set ZO" softkey to measure the workpiece zero.

2.8 Monitoring axis and spindle data

2.8.1 Specify working area limitations

The "Working area limitation" function can be used to limit the range within which a tool can traverse in all channel axes. These commands allow you to set up protection zones in the working area which are out of bounds for tool movements.

In this way, you are able to restrict the traversing range of the axes in addition to the limit switches.

Requirements

You can only make changes in "AUTO" mode when in the RESET condition. These changes are then immediate.

You can make changes in "JOG" mode at any time. These changes, however, only become active at the start of a new motion.

Procedure



1. Select the "Parameter" operating area.



2. Press the "Setting data" softkey.

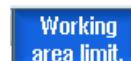

The "Working Area Limitation" window appears.

3. Place the cursor in the required field and enter the new values via the numeric keyboard.

The upper or lower limit of the protection zone changes according to your inputs.

4. Click the "active" checkbox to activate the protection zone.

Note

You will find all of the setting data in the "Start-up" operating area under "Machine data" via the menu forward key.

2.8.2 Editing spindle data

The speed limits set for the spindles that must not be under- or overshoot are displayed in the "Spindles" window.

You can limit the spindle speeds in fields "Minimum" and "Maximum" within the limit values defined in the relevant machine data.

Spindle speed limitation at constant cutting rate

In field "Spindle speed limitation at G96", the programmed spindle speed limitation at constant cutting speed is displayed together with the permanently active limitations.

This speed limitation, for example, prevents the spindle from accelerating to the max. spindle speed of the current gear stage (G96) when performing tapping operations or machining very small diameters.

Note

The "Spindle data" softkey only appears if a spindle is configured.

Procedure

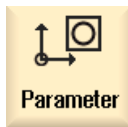

1. Select the "Parameter" operating area.



2. Press the "Setting data" and "Spindle data" softkeys.
The "Spindles" window opens.



3. If you want to change the spindle speed, place the cursor on the "Maximum", "Minimum", or "Spindle speed limitation at G96" and enter a new value.

2.9 Displaying setting data lists

You can display lists with configured setting data.



Machine manufacturer

Please refer to the machine manufacturer's specifications.

Procedure

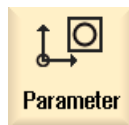

Parameter

1. Select the "Parameter" operating area.



2. Press the "Setting data" and "Data lists" softkeys.
The "Setting Data Lists" window opens.

3. Press the "Select data list" softkey and in the "View" list, select the required list with setting data.

2.10 Handwheel assignment

You can traverse the axes in the machine coordinate system (Machine) or in the workpiece coordinate system (Work) via the handwheel.



Software option

You require the "Extended operator functions" option for the handwheel offset (only for 828D).

All axes are provided in the following order for handwheel assignment:

- Geometry axes

When traversing, the geometry axes taken into account the actual machine status (e.g. rotations, transformations). All channel machine axes, which are currently assigned to the geometry axis, are in this case simultaneously traversed.

- Channel machine axes

Channel machine axes are assigned to the particular channel. They can only be individually traversed, i.e. the actual machine state has no influence.

The also applies to channel machine axes, that are declared as geometry axes.



Machine manufacturer

Please refer to the machine manufacturer's specifications.

Procedure



1. Select the "Machine" operating area.



Press the <JOG>, <AUTO> or <MDI> key.



2. Press the menu forward key and the "Handwheel" softkey.
The "Handwheel" window appears.



A field for axis assignment will be offered for every connected handwheel.

3. Position the cursor in the field next to the handwheel with which you wish to assign the axis (e.g. No. 1).

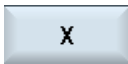

4. Press the corresponding softkey to select the desired axis (e.g. "X").

- OR -



Open the "Axis" selection box using the <INSERT> key, navigate to the desired axis, and press the <INPUT> key.



Selecting an axis also activates the handwheel (e.g., "X" is assigned to handwheel no. 1 and is activated immediately).



5. Press the "Handwheel" softkey again.

- OR -



Press the "Back" softkey.

The "Handwheel" window closes.

Deactivate handwheel

1. Position the cursor on the handwheel whose assignment you wish to cancel (e.g. No. 1).
2. Press the softkey for the assigned axis again (e.g. "X").



- OR -

Open the "Axis" selection box using the <INSERT> key, navigate to the empty field, and press the <INPUT> key.

Clearing an axis selection also clears the handwheel selection (e.g., "X" is cleared for handwheel no. 1 and is no longer active).



2.11 MDA

In "MDA" mode (Manual Data Automatic mode), you can enter G-code commands block-by-block and immediately execute them for setting up the machine.

You can load an MDA program straight from the Program Manager into the MDA buffer. You may also store programs which were rendered or changed in the MDA operating window into any directory of the Program Manager.



Software option

You require the "Extended operator functions" option to load and save MDA programs (for 828D).

2.11.1 Loading an MDA program from the Program Manager

Procedure



1. Select the "Machine" operating area.



2. Press the <MDI> key.

The MDI editor opens.



3. Press the "Load MDI" softkey.

A changeover is made into the Program Manager.

The "Load in MDI" window opens. It shows you a view of the program manager.



4. Position the cursor to the corresponding storage location, press the "Search" softkey and enter the required search term in the search dialog if you wish to search for a specific file.

Note: The place holders "*" (replaces any character string) and "?" (replaces any character) make it easier for you to perform a search.

5. Select the program that you would like to edit or execute in the MDI window.



6. Press the "OK" softkey.

The window closes and the program is ready for operation.

2.11.2 Saving an MDA program

Procedure



1. Select the "Machine" operating area.



2. Press the <MDI> key.

The MDI editor opens.

3. Create the MDI program by entering the G-code commands using the operator's keyboard.



4. Press the "Store MDI" softkey.

The "Save from MDI: Select storage location" window opens. It shows you a view of the program manager.

5. Select the drive to which you want to save the MDI program you created, and place the cursor on the directory in which the program is to be stored.

- OR -



Position the cursor to the required storage location, press the "Search" softkey and enter the required search term in the search dialog if you wish to search for a specific directory or subdirectory.

Note: The place holders "*" (replaces any character string) and "?" (replaces any character) make it easier for you to perform a search.



6. Press the "OK" softkey.

When you place the cursor on a folder, a window opens which prompts you to assign a name.

- OR -

When you place the cursor on a program, you are asked whether the file should be overwritten.



7. Enter the name for the rendered program and press the "OK" softkey.

The program will be saved under the specified name in the selected directory.

2.11.3 Executing an MDA program

Proceed as follows



1. Select the "Machine" operating area.



2. Press the <MDA> key.
The MDA editor opens.



3. Input the desired G-code commands using the operator's keyboard.
4. Press the <CYCLE START> key.

The control executes the input blocks.

When executing the G-code commands, you can control the sequence as follows:

- Executing the program block-by-block
- Testing the program
Settings under program control
- Setting the test-run feedrate
Settings under program control

2.11.4 Deleting an MDA program

Precondition

The MDA editor contains a program that you created in the MDI window or loaded from the program manager.

Procedure



Press the "Delete blocks" softkey.

The program blocks displayed in the program window are deleted.

Execution in manual mode

3.1 General

Always use "JOG" mode when you want to set up the machine for the execution of a program or to carry out simple traversing movements on the machine:

- Synchronize the measuring system of the controller with the machine (reference point approach)
- Set up the machine, i.e. activate manually-controlled motions on the machine using the keys and handwheels provided on the machine control panel.
- You can activate manually controlled motions on the machine using the keys and handwheels provided on the machine control panel while a part program is interrupted.

3.2 Selecting a tool and spindle

3.2.1 T, S, M windows

For the preparatory actions in manual mode, tool selection and spindle control are both performed centrally in a screen form.

In manual mode, you can select a tool either by its name or its location number. If you enter a number, a search is performed for a name first, followed by a location number. This means that if you enter "5", for example, and no tool with the name "5" exists, the tool is selected from location number "5".

Note





Using the location number, you can thus swing around an empty space into the machining position and then comfortably install a new tool.



Machine manufacturer

Please refer to the machine manufacturer's specifications.

3.2 Selecting a tool and spindle

Display	Meaning
T	Input of the tool (name or location number) You can select a tool from the tool list using the "Select tool" softkey.
D	Cutting edge number of the tool (1 - 9)
Spindle	Spindle selection, identification with spindle number
Spindle M function	
	
	
	
Other M functions	Input of machine functions Refer to the machine manufacturer's table for the correlation between the meaning and number of the function.
G work offset	Selection of the work offset (basic reference, G54 - 57) You can select work offsets from the tool list of settable work offsets via the "Work offset" softkey.
Unit of measurement	Selection of the unit of measurement (inch, mm) The setting made here has an effect on the programming.
Machining plane	Selection of the machining plane (G17(XY), G18 (ZX), G19 (YZ))
Gear stage	Specification of the gear stage (auto, I - V)
Stop position	Input of the spindle position in degrees

Note

Spindle positioning

You can use this function to position the spindle at a specific angle, e.g. during a tool change.

- A stationary spindle is positioned via the shortest possible route.
- A rotating spindle is positioned as it continues to turn in the same direction.

3.2.2 Selecting a tool

Procedure

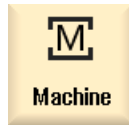

1. Select the "JOG" operating mode.



2. Press the "T, S, M" softkey.



3. Enter the name or the number of the tool T in the input field.

- OR -

Press the "Select tool" softkey to open the tool list, position the cursor on the desired tool and press the "In Manual" softkey.

The tool is transferred to the "T, S, M... window" and displayed in the field of tool parameter "T".



4. Select tool edge D or enter the number directly in field "D".



5. Press the <CYCLE START> key.
The tool is loaded into the spindle.

3.2.3 Starting and stopping a spindle manually

Procedure



1. Select the "JOG" operating mode.



2. Press the "T, S, M" softkey.

3. Select the desired spindle (e.g. S1) and enter the desired spindle speed (rpm) in the adjacent input field.
The spindle remains stationary.



4. If the machine has a gearbox for the spindle, set the gear stage (e.g. auto).



5. Select a spindle direction of rotation (clockwise or counterclockwise) in the "Spindle M function" field.



6. Press the <CYCLE START> key.
The spindle rotates.



7. Select the "Stop" setting in the "Spindle M function" field.



Press the <CYCLE START> key.
The spindle stops.

Note

Changing the spindle speed

If you enter the speed in the "Spindle" field while the spindle is rotating, the new speed is applied.

3.2.4 Position spindle

Procedure



1. Select the "JOG" operating mode.



2. Press the "T, S, M" softkey.



3. Select the "Stop Pos." setting in the "Spindle M function" field.
The "Stop Pos." entry field appears.

4. Enter the desired spindle stop position.
The spindle position is specified in degrees.



5. Press the <CYCLE START> key.

The spindle is moved to the desired position.

Note

You can use this function to position the spindle at a specific angle, e.g. during a tool change.

- A stationary spindle is positioned via the shortest possible route.
 - A rotating spindle is positioned as it continues to turn in the same direction.
-

3.3 Traversing axes

You can traverse the axes in manual mode via the Increment or Axis keys or handwheels.

During a traverse initiated from the keyboard, the selected axis moves at the programmed setup feedrate. During an incremental traverse, the selected axis traverses a specified increment.

Set the default feedrate

Specify the feedrate to be used for axis traversal in the set-up, in the "Settings for Manual Operation" window.

3.3.1 Traverse axes by a defined increment

You can traverse the axes in manual mode via the Increment and Axis keys or handwheels.

Procedure



1. Select the "Machine" operating area.



2. Press the <JOG> key.



3. Press keys 1, 10, etc. up to 10000 in order to move the axis in a defined increment.

The numbers on the keys indicate the traverse path in micrometers or microinches.

Example: Press the "100" button for a desired increment of 100 μm (= 0.1 mm).



4. Select the axis to be traversed.



5. Press the <+> or <-> key.

Each time you press the key the selected axis is traversed by the defined increment.

Feedrate and rapid traverse override switches can be operative.

Note

When the controller is switched on, the axes can be traversed right up to the limits of the machine as the reference points have not yet been approached and the axes referenced. Emergency limit switches might be triggered as a result.

The software limit switches and the working area limitation are not yet operative!

The feed enable signal must be set.

**Machine manufacturer**

Please refer to the machine manufacturer's specifications.

3.3.2 Traversing axes by a variable increment

Procedure

Machine

1. Select the "Machine" operating area.



Press the <JOG> key.



2. Press the "Settings" softkey.
The "Settings for Manual Operation" window is opened.

3. Enter the desired value for the "Variable increment" parameter.
Example: Enter 500 for a desired increment of 500 μm (0.5 mm).



4. Press the <Inc VAR> key.

5. Select the axis to be traversed.



6. Press the <+> or <-> key.

Each time you press the key the selected axis is traversed by the set increment.



Feedrate and rapid traverse override switches can be operative.

3.4 Positioning axes

In manual mode, you can traverse individual or several axes to certain positions in order to implement simple machining sequences.

The feedrate / rapid traverse override is active during traversing.

Procedure



1. If required, select a tool.
2. Select the "JOG" operating mode.



3. Press the "Positions" softkey.



4. Specify the desired value for the feedrate F.
- OR -

Press the "Rapid traverse" softkey.

The rapid traverse is displayed in field "F".

5. Enter the target position or target angle for the axis or axes to be traversed.



6. Press the <CYCLE START> key.

The axis is traversed to the specified target position.

If target positions were specified for several axes, the axes are traversed simultaneously.

3.5 Swiveling

Manual swivel in the JOG mode provides functions that make it far easier to setup, measure, and machine workpieces with swiveled surfaces.

If you want to create or correct an inclined position, the required rotations of the workpiece coordinate system around the geometry axes (X, Y, Z) are automatically converted into suitable positions of the machine kinematics.

Alternatively, you can program the swivel axes of the machine "directly" and generate a matching workpiece coordinate system for those swivel axis positions. After swiveling, the tool axis (for G17 Z) is always perpendicular to the working plane (for G17 XY).

The swiveled coordinates are maintained in the Reset status and after Power On, if the machine manufacturer has correspondingly set the machine data. With these settings, after a program interrupt, e.g. as a result of a retraction in the +Z direction, you can retract from an inclined hole.



Machine manufacturer

Please refer to the machine manufacturer's specifications.

Important parameters

- **TC - name of swivel data record**

Here you can select the swivel data record.

- **Retraction**

Before swiveling the axes you can move the tool to a safe retraction position. The retraction methods available to you are defined in the "Retraction position" parameter during set-up of the swivel data record.

"Retraction" corresponds to Parameter `_FR` of CYCLE800.



Machine manufacturer

Please refer to the machine manufacturer's specifications. Due to additional swivel data records (e.g. for tool change) additional retraction versions can be enabled.

WARNING

Select a retraction position so that no collision can occur between the tool and workpiece when swiveling.

3.5 Swiveling

- **Swivel plane**

You can start the swivel plane as "new" or "additive" to a swivel plane that is already active.

- **Swivel mode**

Swiveling can be axis by axis or direct.

- Axis-by-axis swiveling is based on the coordinate system of the workpiece (X, Y, Z). The coordinate axis sequence can be selected freely. Rotations are applied in the selected sequence. The rotation of the two rotary axes (A, B or C) is calculated from this.
- For direct swiveling, the required positions of the rotary axes are specified. A suitable new coordinate system is calculated based on those values. The tool axis is aligned in the Z direction. You can derive the resulting direction of the X and Y axis by traversing the axes.

Note

The positive direction of each rotation for the different swivel methods is shown in the help displays.

- **Direction**

"Direction" corresponds to the parameter `_DIR` of CYCLE800.

For swivel systems with 2 rotary axes, a particular plane can be reached in two different ways. You can choose between these two different positions in the "Direction" parameter. The +/- corresponds to the larger or smaller value of a rotary axis. This may affect the working area.

When the swivel data record is set up, the entries in the "Direction" parameter determine for which rotary axis you can select each of the two settings.

If one of the two positions cannot be reached for mechanical reasons, the alternative position is automatically selected irrespective of the setting of the "Direction" parameter.



Machine manufacturer

Please refer to the machine manufacturer's specifications.

- **Correcting tool**

"Tool" corresponds to the Parameter `_ST=1x` (correct tool tip) of CYCLE800.

To avoid collisions, you can use the 5-axis transformation (software option) to retain the position of the tool tip during swiveling.

When machine manufacturer commissions the function "Swivel Manually", "Track Tool" must be enabled.

**Machine manufacturer**

Please refer to the machine manufacturer's specifications.

• Zero plane

The zero plane corresponds to the tool plane (G17, G18, G19) including the active zero offset (G500, G54, ...). Rotations of the active zero offset and the rotary axes are taken into account for manual swiveling.

The "Swivel Manually" function only writes rotations either in the workpiece reference (\$_WPFRAME) or in the active zero offset.

You can use the "Swivel Manually" function not only for machining, but also for setting-up.

- You can bring the machine into the initial position using the "Basic setting" softkey and the <CYCLE START> key. If the actual zero offset does not include a rotation, then the rotary axes of the swivel data record are moved to zero. The tool is located vertically to the machining plane.

If you want to use the actual swiveled plane as the reference plane for setting up your workpiece, you must define this plane as the zero plane.

- With "Set zero plane" the actual swivel plane in the active zero offset is stored as the zero plane. As a result, the rotations in the active zero offset are overwritten.
- With "Delete zero plane", the rotations in the active zero offset are set to zero.

Note

The overall coordinate system does not change with "Set zero plane" or "Delete zero plane".

**Machine manufacturer**

Basic setting of the machine kinematics for "Swivel Manually" and "5-axis transformation".

Please refer to the machine manufacturer's specifications.

3.5 Swiveling

Procedure



1. Select the "Machine" operating area.



2. Press the <JOG> key



3. Press the "Swivel" softkey.



4. Enter the desired value for the parameter and press the <CYCLE START> key.

The "Swivel" cycle is started.



Press the "Basic setting" softkey and the <CYCLE START> key to move the machine into the initial position.

If the actual zero offset does not include a rotation, then the rotary axes of the swivel data record are moved to zero. The tool is located vertically to the machining plane.

This is done, for example, to swivel the coordinate system back to its original orientation.





Press the "Set zero plane" softkey to set the actual swivel plane to the new zero plane.



Press the "Delete zero plane" softkey to delete the actual swivel plane.

Parameter	Description	Unit
TC	Name of the swivel data record 0: Remove the swivel head, deselect the swivel data record No entry: No change to the set swivel data record	
Retraction 	<ul style="list-style-type: none"> No: No retraction before swiveling Fixed point 1: Retraction in the direction of machine axis Z to the fixed point of machine axis Z defined by the machine manufacturer Z. Fixed point 2: Retraction in the direction of machine axis Z and then in X,Y to the fixed points defined by the machine manufacturer Retraction, maximum in the tool direction up to the software end position Retraction, incremental in the tool direction up to a maximum of the software end position. The retraction path is entered into parameter ZR. 	
Swivel plane 	<ul style="list-style-type: none"> New: New swivel plane Additive: Additive swivel plane 	

Parameter	Description	Unit
Swivel mode 	<ul style="list-style-type: none"> Axis by axis: Rotate coordinate system axis-by-axis Direct: Directly position rotary axes Positions the rotary axes of the active swivel data record Angle of rotation in the plane around the tool axes	
Z	Angle of rotation in the plane (direct swivel)	Degrees
Axis sequence 	Sequence of the axes which are rotated around: XYZ, XZY, YXZ, YZX, ZXY, ZYX	
X	Rotation around X	Degrees
Y	Rotation around Y	Degrees
Z	Rotation around Z	Degrees
Name of rotary axis 1	Axis angle for swivel, direct	Degrees
Name of rotary axis 2	Axis angle for swivel, direct	Degrees
Direction	Preferred direction of rotation for two alternatives (swiveling axis-by-axis) +: Larger angle of the axis on the scale of the swivel head / swivel table -: Smaller angle of the axis on the scale of the swivel head / swivel table	
Tool	Correction: The position of the tool tip is maintained during swiveling No correction: The position of the tool tip changes during swiveling	

3.6 Manual retraction

After an interruption of a tapping operation (G33/G331/G332) or a general drilling operation (tools 200 to 299) due to power loss or a RESET at the machine control panel, you have the possibility to retract the tool in the JOG mode in the tool direction without damaging the tool or the workpiece.

The retraction function is especially useful when the coordinate system is swiveled, i.e. the infeed axis is not in the vertical position.

Note

Tapping

In the case of tapping, the form fit between the tap and the workpiece is taken into account and the spindle moved according to the thread.

The Z axis as well as the spindle can be used for retraction at the thread.

The "Retraction" function must be set up by the machine manufacturer.



Machine manufacturer

Please refer to the machine manufacturer's specifications.

Procedure



1. <RESET> interrupts the power supply to the machine and any running part program.
2. After a power supply interruption, switch on the controller.
3. Select the JOG operating mode.
4. Press the Menu forward key.
5. Press the "Retract" softkey.
The "Retract Tool" window opens.
The softkey is available only when an active tool and retraction data are present.
6. Select the "WCS" coordinate system on the machine control panel.



7. Select the required axis in the "Retraction axis" selection box.

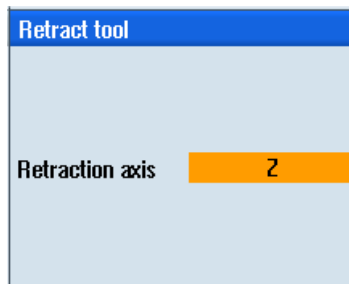

8. Use the traversing keys (e.g. Z +) to traverse the tool from the workpiece according to the retraction axis selected in the "Retract Tool" window.



9. To exit the window, press the "Retract" softkey again when the tool is at the desired position.

3.7 Simple face milling of the workpiece

You can use this cycle to face mill any workpiece. A rectangular surface is always machined.

Selecting the machining direction

In the "Direction" field, using the SELECT key, select the desired machining direction:

- Same direction of machining
- Alternating direction of machining

Selecting limits

You can select the limits using the appropriate softkeys:

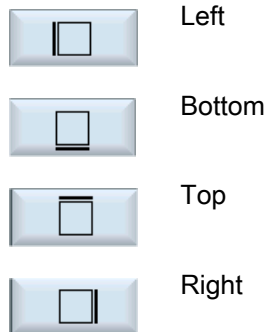

Retraction plane / safety clearance

The retraction plane and safety clearance are set using the machine data \$SCS_MAJOG_SAFETY_CLEARANCE or \$SCS_MAJOG_RELEASE_PLANE.



Machine manufacturer

Please refer to the machine manufacturer's specifications.

Direction of spindle rotation

If the "ShopTurn/ShopMill" option is activated, the direction of spindle rotation is taken from the tool parameters entered in the tool list.

If the "ShopTurn/ShopMill" option is not set, select the direction of spindle rotation in the input screen.

See also

Face milling (CYCLE61) (Page 334)

Precondition

To carry out simple stock removal of a workpiece in manual mode, a measured tool must be in the machining position.

Procedure



1. Select the "Machine" operating area.



2. Press the <JOG> key.



3. Press the <Face milling> softkey.



4. Press the relevant softkey to specify the lateral limitations of the workpiece.



5. Select the machining type (e.g. roughing) in the "Machining" field.



6. Select the machining direction in the "Direction" field.

7. Enter all other parameters in the input screen.



8. Press the "OK" softkey.
The parameter screen is closed.

















9. Press the <CYCLE START> key.
The face milling cycle is started.
You can return to the parameter screen at any time to check and correct the inputs.

Note

You cannot use the "Repos" function while face milling.

3.7 Simple face milling of the workpiece

Parameter	Description	Unit
T	Tool name	
D	Cutting edge number	
F 	Feedrate	mm/min mm/rev
S / V	Spindle speed or constant cutting rate	rpm m/min
Spindle M function	Direction of spindle rotation (only when ShopMill is not active) <ul style="list-style-type: none">   	
Machining 	The following machining operations can be selected: <ul style="list-style-type: none">  (roughing)  (finishing) 	
Direction 	Same direction of machining <ul style="list-style-type: none">   Alternating direction of machining <ul style="list-style-type: none">   	
X0	Corner point 1 of surface in X direction (abs. or inc.)	mm
Y0	Corner point 1 of surface in Y direction (abs. or inc.)	mm
Z0	Height of blank (abs. or inc.)	mm
X1 	Corner point 2 of surface in X direction (abs. or inc.)	mm
Y1 	Corner point 2 of surface in Y direction (abs. or inc.)	mm
Z1 	Height of finished part (abs. or inc.)	mm
DXY	Max. infeed in the XY plane (dependent on milling cutter diameter) Alternatively, you can specify the plane infeed as a %, as a ratio → plane infeed (mm) to milling cutter diameter (mm).	mm %
DZ	Max. infeed in Z direction - (only for roughing)	mm
UZ	Finishing allowance, depth	mm

Note

The same finishing allowance must be entered for both roughing and finishing. The finishing allowance is used to position the tool for retraction.

See also

Tool, offset value, feed and spindle speed (T, D, F, S, V) (Page 262)

3.8 Default settings for manual mode

Specify the configurations for manual mode in the "Settings for manual operation" window.

Presettings

Settings	Description
Type of feedrate	Here, you select the type of feedrate.
	<ul style="list-style-type: none"> • G94: Axis feedrate/linear feedrate • G95: Rev. feedrate
Default feedrate G94	Enter the desired feedrate in mm/min.
Default feedrate G95	Enter the desired feedrate in mm/r.
Variable increment	Enter the desired increment for axis traversal by variable increments.
Spindle speed	Enter the desired spindle speed in rpm.

Proceed as follows



1. Select the "Machine" operating area.



2. Press the <JOG> key.



3. Press the menu forward key and the "Settings" softkey.
The "Settings for manual operation" window is opened.



Machining the workpiece

4.1 Starting and stopping machining

During execution of a program, the workpiece is machined in accordance with the programming on the machine. After the program is started in automatic mode, workpiece machining is performed automatically.

Requirements

The following requirements must be met before executing a program:

- The measuring system of the controller is referenced with the machine.
- The necessary tool offsets and zero offsets have been entered.
- The necessary safety interlocks implemented by the machine manufacturer are activated.

General sequence



1. Use the Program manager to select the desired program.



Select the desired program under "NC", "Local drive", "USB" or set-up network drives.



3. Press the "Select" softkey.
The program is selected for execution and automatically switched to the "Machine" operating area.



4. Press the <CYCLE START> key.
The program is started and executed.

Note

Starting the program in any operating area

If the controller is in "AUTO" mode, you can also start the selected program when you are in any operating area.

Stopping machining



Press the <CYCLE STOP> key.

Machining stops immediately. Individual program blocks are not executed to the end. On the next start, machining is resumed from the point where it left off.

Canceling machining



Press the <RESET> key.

Execution of the program is interrupted. On the next start, machining will start from the beginning.



Machine manufacturer

Please refer to the machine manufacturer's specifications.

4.2 Selecting a program

Procedure



1. Select the "Program manager" operating area.
The directory overview is opened.



2. Place the cursor on the directory containing the program that you want to select.
3. Press the <INPUT> key

- OR -



Press the <Cursor right> key.

The directory contents are displayed.



4. Place the cursor on the desired program.
5. Press the "Select" softkey.

The program is selected.

When the program has been successfully selected, an automatic changeover to the "Machine" operating area occurs.

4.3 Testing a program

When testing a program, the system can interrupt the machining of the workpiece after each program block, which triggers a movement or auxiliary function on the machine. In this way, you can control the machining result block-by-block during the initial execution of a program on the machine.

Note

Settings for the automatic mode

Rapid traverse reduction and dry run feed rate are available to run-in or to test a program.

Move by single block

In "Program control" you may select from among several types of block processing:

SB mode	Scope
SB1 Single block, coarse	The machining stops after every machine block (except for cycles)
SB2 Data block	The machining stops after every block, i.e. also for data blocks (except for cycles)
SB3 Single block, fine	The machining stops after every machine block (also in cycles)

Precondition

A program must be selected for execution in "AUTO" or "MDA" mode.

Procedure



1. Press the "Prog. ctrl." softkey and select the desired variant in the "SBL" field.



2. Press the <SINGLE BLOCK> key.



3. Press the <CYCLE START> key.
Depending on the execution variant, the first block will be executed. Then the machining stops.

In the channel status line, the text "Stop: Block in single block ended" appears.



4. Press the <CYCLE START> key.
Depending on the mode, the program will continue executing until the next stop.



5. Press the <SINGLE BLOCK> key again, if the machining is not supposed to run block-by-block.

The key is deselected again.



If you now press the <CYCLE START> key again, the program is executed to the end without interruption.

4.4 Displaying the current program block

4.4.1 Current block display

The window of the current block display shows you the program blocks currently being executed.

Display of current program

The following information is displayed in the running program:

- The workpiece name or program name is entered in the title row.
- The program block which is just being processed appears colored.

Editing a program directly

In the Reset state, you can edit the current program directly.



1. Press the <INSERT> key.

2. Place the cursor at the relevant position and edit the program block.
Direct editing is only possible for G code blocks in the NC memory, not for external execution.



3. Press the <INSERT> key to exit the program and the edit mode again.

4.4.2 Displaying a basic block

If you want precise information about axis positions and important G functions during testing or program execution, you can call up the basic block display. This is how you can check, when using cycles, for example, whether the machine is actually traversing.

Positions programmed by means of variables or R parameters are resolved in the basic block display and replaced by the variable value.

You can use the basic block display both in test mode and when machining the workpiece on the machine. All G code commands that initiate a function on the machine are displayed in the "Basic Blocks" window for the currently active program block:

- Absolute axis positions
- G functions for the first G group
- Other modal G functions
- Other programmed addresses
- M functions



Machine manufacturer

Please refer to the machine manufacturer's specifications.

Procedure



1. A program is selected for execution and has been opened in the "Machine" operating area.
2. Press the "Basic blocks" softkey.
The "Basic Blocks" window opens.
3. Press the <SINGLE BLOCK> key if you wish to execute the program block-by-block.
4. Press the <CYCLE START> key to start the program execution.
The axis positions to be approached, modal G functions, etc., are displayed in the "Basic Blocks" window for the currently active program block.
5. Press the "Basic blocks" softkey once again to hide the window again.

4.4.3 Display program level

You can display the current program level during the execution of a large program with several subprograms.

Several program run throughs

If you have programmed several program run throughs, i.e. subprograms are run through several times one after the other by specifying the additional parameter P, then during processing, the program runs still to be executed are displayed in the "Program Levels" window.

Program example

N10 subprogram P25

If, in at least one program level, a program is run through several times, a horizontal scroll bar is displayed that allows the run through counter P to be viewed in the righthand window section. The scroll bar disappears if multiple run-through is no longer applicable.

Display of program level

The following information will be displayed:

- Level number
- Program name
- Block number, or line number
- Remain program run throughs (only for several program run throughs)

Precondition

A program must be selected for execution in "AUTO" mode.

Procedure



Press the "Program levels" softkey.
The "Program levels" window appears.

4.5 Correcting a program

As soon as a syntax error in the part program is detected by the controller, program execution is interrupted and the syntax error is displayed in the alarm line.

Correction possibilities

Depending on the state of the control system, you can make the following corrections using the Program editing function.

- Stop mode
Only program lines that have not yet been executed can be edited.
- Reset mode
All program lines can be edited.

Note

The "program correction" function is also available for execute from external; however, when making program changes, the NC channel must be brought into the reset state.

Requirement

A program must be selected for execution in "AUTO" mode.

Procedure



1. The program to be corrected is in the Stop or Reset mode.
2. Press the "Prog. corr." softkey

The program is opened in the editor.

The program preprocessing and the current block are displayed. The current block is also updated in the running program, but not the displayed program section, i.e. the current block moves out of the displayed program section.

If a subprogram is executed, it is not opened automatically.

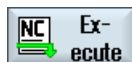

3. Make the necessary corrections.
4. Press the "NC Execute" softkey.

The system switches back to the "Machine" operating area and selects "AUTO" mode.



5. Press the <CYCLE START> key to resume program execution.

Note

Exit the editor using the "Close" softkey to return to the "Program manager" operating area.

4.6 Repositioning axes

After a program interruption in automatic mode (e.g. after a tool breaks) you can move the tool away from the contour in manual mode.

The coordinates of the interrupt position will be saved. The distances traversed in manual mode are displayed in the actual value window. This path difference is called "Repos-offset".

Resuming program execution

Using the "Repos" function, you can return the tool to the contour in order to continue executing the program.

You cannot traverse the interrupt position, because it is blocked by the control system.

The feedrate/rapid traverse override is in effect

NOTICE

Risk of collision

When repositioning, the axes move with the programmed feedrate and linear interpolation, i.e. in a straight line from the current position to the interrupt point. Therefore, you must first move the axes to a safe position in order to avoid collisions.

If you do not use the "Repos" function and subsequently move the axes in manual mode after a program interrupt, the control automatically moves the axes during the switch to automatic mode and the subsequent start of the machining process in a straight line back to the point of interruption.
--

Precondition

The following prerequisites must be met when repositioning the axes:

- The program execution was interrupted using <CYCLE STOP>.
- The axes were moved from the interrupt point to another position in manual mode.

Procedure



1. Press the <REPOS> key.



2. Select the axes to be traversed one after the other.



3. Press the <+> or <-> key for the relevant direction.
The axes are moved to the interrupt position.



4.7 Starting machining at a specific point

4.7.1 Use block search

If you would only like to perform a certain section of a program on the machine, then you need not start the program from the beginning. You can also start the program from a specified program block.

Applications

- Stopping or interrupting program execution
- Specify a target position, e.g. during remachining

Determining a search target

- User-friendly search target definition (search positions)
 - Direct specification of the search target by positioning the cursor in the selected program (main program)
 - Search target via text search
 - The search target is the interruption point (main program and subprogram)

The function is only available if there is an interruption point. After a program interruption (CYCLE STOP or RESET), the controller saves the coordinates of the interruption point.
 - The search target is the higher program level of the interruption point (main program and subprogram)

The level can only be changed if it was previously possible to select an interruption point in a subprogram. It is then possible to change the program level up to the main program level and back to the level of the interruption point.
- Search pointer
 - Direct entry of the program path

Note

You can search for a specific point in subprograms with the search pointer if there is no interruption point.



Software option

You require the "Extended operator functions" option for the "Search pointer" function (only for 828D).

Cascaded search

You can start another search from the "Search target found" state. The cascading can be continued any number of times after every search target found.

Note

Another cascaded block search can be started from the stopped program execution only if the search target has been found.

References

Function Manual Basic Functions; Block Search

Preconditions

1. You have selected the desired program.
2. The controller is in the reset state.
3. The desired search mode is selected.

NOTICE
Risk of collision Pay attention to a collision-free start position and appropriate active tools and other technological values. If necessary, manually approach a collision-free start position. Select the target block considering the selected block search type.

toggling between search pointer and search positions



Press the "Search pointer" softkey again to exit the "Search Pointer" window and return to the "Program" window to define search positions.

- OR -



Press the "Back" softkey.

You have now exited the block search function.

See also

Selecting a program (Page 151)

4.7.2 Continuing program from search target

To continue the program at the desired position, press the <CYCLE START> key twice.

- The first CYCLE START outputs the auxiliary functions collected during the search. The program is then in the Stop state.
- Before the second CYCLE START, you can use the "Overstore" function to create states that are required, but not yet available, for the further program execution.

By changing to the JOG REPOS mode, you can also manually traverse the tool from the current position to the setpoint position, if the setpoint position is not to be automatically approached after the program start

4.7.3 Simple search target definition

Requirement

The program is selected and the controller is in Reset mode.

Procedure



1. Press the "Block search" softkey.

2. Place the cursor on a particular program block.

- OR -



Press the "Find text" softkey, select the search direction, enter the search text and confirm with "OK".

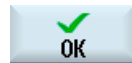

3. Press the "Start search" softkey.

The search starts. Your specified search mode will be taken into account.

The current block will be displayed in the "Program" window as soon as the target is found.



4. If the located target (for example, when searching via text) does not correspond to the program block, press the "Start search" softkey again until you find your target.

Press the <CYCLE START> key twice.

Processing is continued from the defined position.

4.7.4 Defining an interruption point as search target

Requirement

A program was selected in "AUTO" mode and interrupted during execution through CYCLE STOP or RESET.



Software option

You require the "Extended operator functions" option (only for 828D).

Procedure



1. Press the "Block search" softkey.



2. Press the "Interrupt point" softkey.
The interruption point is loaded.



3. If the "Higher level" and "Lower level" softkeys are available, use these to change the program level.



4. Press the "Start search" softkey.

The search starts. Your specified search mode will be taken into account.

The search screen closes.

The current block will be displayed in the "Program" window as soon as the target is found.



5. Press the <CYCLE START> key twice.

The execution will continue from the interruption point.

4.7.5 Entering the search target via search pointer

Enter the program point which you would like to proceed to in the "Search Pointer" window.



Software option

You require the "Extended operator functions" option for the "Search pointer" function (only for 828D).

Requirement

The program is selected and the controller is in the reset state.

Screen form

Each line represents one program level. The actual number of levels in the program depends on the nesting depth of the program.

Level 1 always corresponds to the main program and all other levels correspond to subprograms.

You must enter the target in the line of the window corresponding to the program level in which the target is located.

For example, if the target is located in the subprogram called directly from the main program, you must enter the target in program level 2.

The specified target must always be unambiguous. This means, for example, that if the subprogram is called in the main program in two different places, you must also specify a target in program level 1 (main program).

Procedure



1. Press the "Block search" softkey.



2. Press the "Search pointer" softkey.

3. Enter the full path of the program as well as the subprograms, if required, in the input fields.



4. Press the "Start search" softkey.

The search starts. Your specified search mode will be taken into account.

4.7 Starting machining at a specific point

The Search window closes. The current block will be displayed in the "Program" window as soon as the target is found.



5. Press the <CYCLE START> key twice.
Processing is continued from the defined location.

Note

Interruption point

You can load the interruption point in search pointer mode.

4.7.6 Parameters for block search in the search pointer

Parameter	Meaning
	Number of program level
Program:	The name of the main program is automatically entered
Ext:	File extension
P:	Pass counter If a program section is performed several times, you can enter the number of the pass here at which processing is to be continued
Line:	Is automatically filled for an interruption point
Type	" " search target is ignored on this level N no. Block number Label Jump label Text string Subprg. Subprogram call Line Line number
Search target	Point in the program at which machining is to start

4.7.7 Block search mode

Set the desired search variant in the "Search Mode" window.

The set mode is retained when the the controller is shut down. When you activate the "Search" function after restarting the controller, the current search mode is displayed in the title row.

Search variants

Block search mode	Meaning
With calculation - without approach	It is used in order to be able to approach a target position in any circumstance (e.g. tool change position). The end position of the target block or the next programmed position is approached using the type of interpolation valid in the target block. Only the axes programmed in the target block are moved. Note: If machine data 11450.1=1 is set, the rotary axes of the active swivel data record are pre-positioned after the block search.
With calculation - with approach	It is used to be able to approach the contour in any circumstance. The end position of the block prior to the target block is found with <CYCLE START>. The program runs in the same way as in normal program processing.
With calculation - skip extcall	This is used to speed-up a search with calculation when using EXTCALL programs: EXTCALL programs are not taken into account. Notice: Important information, e.g. modal functions, which are located in the EXTCALL program, are not taken into account. In this case, after the search target has been found, the program is not able to be executed. Information such as this should be programmed in the main program.
Without calculation	For a quick search in the main program. Calculations will not be performed during the block search, i.e. the calculation is skipped up to the target block. All settings required for execution have to be programmed from the target block (e.g. feedrate, spindle speed, etc.).
With program test	Multi-channel block search with calculation (SERUPRO). All blocks are calculated during the block search. Absolutely no axis motion is executed, however, all auxiliary functions are output. The NC starts the selected program in the program test mode. If the NC reaches the specified target block in the actual channel, it stops at the beginning of the target block and deselects program test mode again. After continuing the program with NC start (after REPOS motion) the auxiliary functions of the target block are output. For single-channel systems, the coordination is supported with events running in parallel, e.g. synchronized actions. Note The search speed depends on MD settings.

Note

Search mode for the ShopMill and ShopTurn programs

The search variant for the ShopMill/ShopTurn machining step programs can be specified via MD 51024. This applies only to the ShopMill/ShopTurn single-channel view.



Machine manufacturer

Please refer to the machine manufacturer's specifications.

References

For additional information, please refer to the following documentation:

Commissioning Manual SINUMERIK Operate (IM9) / SINUMERIK 840D sl

Procedure



1. Select the "Machine" operating area.



2. Press the <AUTO> key.



3. Press the "Block search" and "Block search mode" softkeys. The "Search Mode" window appears.



4.8 Controlling the program run

4.8.1 Program control

You can change the program sequence in the "AUTO" and "MDI" modes.

Abbreviation/program control	Mode of operation
PRT no axis motion	The program is started and executed with auxiliary function outputs and dwell times. In this mode, the axes are not traversed. The programmed axis positions and the auxiliary function outputs are controlled this way. Note: Program processing without axis motion can also be activated with the function "Dry run feedrate".
DRY Dry run feedrate	The traversing velocities programmed in conjunction with G1, G2, G3, CIP and CT are replaced by a defined dry run feedrate. The dry run feedrate also applies instead of the programmed revolutional feedrate. Caution: Workpieces must not be machined when "Dry run feedrate" is active because the altered feedrates might cause the permissible tool cutting rates to be exceeded and the workpiece or machine tool could be damaged.
RG0 Reduced rapid traverse	In the rapid traverse mode, the traversing speed of the axes is reduced to the percentage value entered in RG0. Note: You define the reduced rapid traverse in the settings for automatic operation.
M01 Programmed stop 1	The processing of the program stops at every block in which supplementary function M01 is programmed. In this way you can check the already obtained result during the processing of a workpiece. Note: In order to continue executing the program, press the <CYCLE START> key again.
Programmed stop 2 (e.g. M101)	The processing of the program stops at every block in which the "Cycle end" is programmed (e.g. with M101). Note: In order to continue executing the program, press the <CYCLE START> key again. Note: The display can be changed. Please refer to the machine manufacturer's specifications.
DRF Handwheel offset	Enables an additional incremental zero offset while processing in automatic mode with an electronic handwheel. This function can be used to compensate for tool wear within a programmed block. Note: You require the "Extended operator functions" option to use the handwheel offset (for 828D).
SB	Individual blocks are configured as follows. Single block, coarse: The program stops only after blocks which perform a machine function. Data block: The program stops after each block. Single block, fine: The program also only stops after blocks which perform a machine function in cycles. Select the desired setting using the <SELECT> key.
SKP	Skip blocks are skipped during machining.
GCC	When executing a jobshop program, it is converted into a G-code program.

Activating program control

You can control the program sequence however you wish by selecting and clearing the relevant checkboxes.

Display / response of active program controls:

If a program control is activated, the abbreviation of the corresponding function appears in the status display as response.

Procedure



1. Select the "Machine" operating area.



2. Press the <AUTO> or <MDI> key.



3. Press the "Prog. ctrl." softkey.
The "Program Control" window appears.

4.8.2 Skip blocks

It is possible to skip program blocks, which are not to be executed every time the program runs.

The skip blocks are identified by placing a "/" (forward slash) or "/x (x = number of skip level) character in front of the block number. Several consecutive blocks can also be skipped.

The statements in the skipped blocks are not executed, i.e. the program continues with the next block, which is not skipped.

The number of skip levels that can be used depends on a machine datum.



Machine manufacturer

Please refer to the machine manufacturer's specifications.



Software option

In order to have more than two skip levels, for 828D you require the "Extended operator functions" option.

Skip levels, activate

Select the corresponding checkbox to activate the desired skip level.

Note

The "Program Control - Skip Blocks" window is only available when more than one skip level is set up.

Procedure



1. Select the "Machine" operating area.



2. Press the <AUTO> or <MDA> key.



3. Press the "Prog. ctrl." and "Skip blocks" softkeys.
The "Program Control" window appears and shows a list of skip levels.

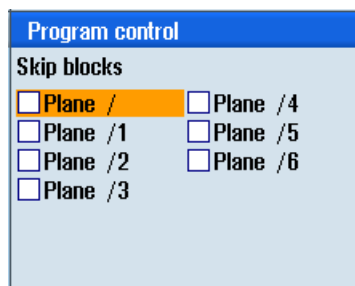

4.9 Overstore

With overstore, you have the option of executing technological parameters (for example, auxiliary functions, axis feed, spindle speed, programmable instructions, etc.) before the program is actually started. The program instructions act as if they are located in a normal part program. These program instructions are, however, only valid for one program run. The part program is not permanently changed. When next started, the program will be executed as originally programmed.

After a block search, the machine can be brought into another state with overstore (e.g. M function, tool, feed, speed, axis positions etc.), in which the normal part program can be successfully continued.



Software option

You require the "Extended operator functions" option for the overstore function (for 828D).

Precondition

The program to be corrected is in the Stop or Reset mode.

Procedure



1. Open the program in the "AUTO" mode.



2. Press the "Overstore" softkey.
The "Overstore" window opens.

3. Enter the required data and NC block.



4. Press the <CYCLE START> key.

The blocks you have entered are stored. You can observe execution in the "Overstore" window.

After the entered blocks have been executed, you can append blocks again.

You cannot change the operating mode while you are in overstore mode.



5. Press the "Back" softkey.
The "Overstore" window closes.



6. Press the <CYCLE START> key again.
The program selected before overstore continues to run.

Note

Block-by-block execution

The <SINGLE BLOCK> key is also active in the overstore mode. If several blocks are entered in the overstore buffer, then these are executed block-by-block after each NC start

Deleting blocks



Press the "Delete blocks" softkey to delete program blocks you have entered.

4.10 Editing a program

With the editor, you are able to render, supplement, or change part programs.

Note

Maximum block length

The maximum block length is 512 characters.

Calling the editor

- The editor is started via the "Program correction" function in the "Machine" operating area and with the <INSERT> key.
- The editor is called via the "Open" softkey as well as with the <INPUT> or <Cursor right> key in the "Program manager" operating area.
- The editor opens in the "Program" operating area with the last executed part program, if this was not explicitly exited via the "Close" softkey.

Note

Please note that the changes to programs stored in the NC memory take immediate effect. You can exit the editor only after you have saved the changes.

If you are editing on a local drive or external drives, you can also exit the editor without saving, depending on the setting.

Exit the program correction mode using the "Close" softkey to return to the "Program manager" operating area.

See also

Editor settings (Page 181)

Opening and closing the program (Page 578)

Correcting a program (Page 156)

Generating a G code program (Page 237)

4.10.1 Searching in programs

You can use the search function to quickly arrive at points where you would like to make changes, e.g. in very large programs.

Various search options are available that enable selective searching.

Search options

- Whole words

Activate this option and enter a search term if you want to search for texts/terms that are present as words in precisely this form.

If, for example, you enter the search term "Finishing tool", only single "Finishing tool" terms are displayed.

- Exact expression

Activate this option if you want to search for place holders in program lines (e.g. "*" or "?") that you want to replace.

Note

Search with place holders

When searching for specific program locations, you have the option of using place holders:

- "*": Replaces any character string
 - "?": Replaces any character
-

Requirement

The desired program is opened in the editor.

Procedure



1. Press the "Search" softkey.
A new vertical softkey bar appears.
The "Search" window opens at the same time.
2. Enter the desired search term in the "Text" field.
3. Select "Whole words" if you want to search for whole words only.
- OR -
Activate the "Exact expression" checkbox if, for example, you want to search for place holders ("*", "?") in program lines.
4. Position the cursor in the "Direction" field and choose the search direction (forward, backward) with the <SELECT> key.





5. Press the "OK" softkey to start the search.

If the text you are searching for is found, the corresponding line is highlighted.





6. Press the "Continue search" softkey if the text located during the search does not correspond to the point you are looking for.

- OR -



Press the "Cancel" softkey when you want to cancel the search.

Further search options

Softkey	Function
	The cursor is set to the first character in the program.
	The cursor is set to the last character in the program.

4.10.2 Replacing program text

You can find and replace text in one step.

Requirement

The desired program is opened in the editor.

Procedure



1. Press the "Search" softkey.
A new vertical softkey bar appears.



2. Press the "Find and replace" softkey.
The "Find and Replace" window appears.

3. In the "Text" field, enter the term you are looking for and in the "Replace with" field, enter the text you would like to insert automatically during the search.



4. Position the cursor in the "Direction" field and choose the search direction (forward, backward) with the <SELECT> key.

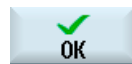

5. Press the "OK" softkey to start the search.
If the text you are searching for is found, the corresponding line is highlighted.



6. Press the "Replace" softkey to replace the text.

- OR -



Press the "Replace all" softkey to replace all text in the file that corresponds to the search term.

- OR -



Press the "Continue search" softkey if the text located during the search should not be replaced.

- OR -



Press the "Cancel" softkey when you want to cancel the search.

Note

Replacing texts

- Read-only lines (;*RO*)
If hits are found, the texts are not replaced.
 - Contour lines (;*GP*)
If hits are found, the texts are replaced as long as the lines are not read-only.
 - Hidden lines (;*HD*)
If hidden lines are displayed in the editor and hits are found, the texts are replaced as long as the lines are not read-only. Hidden lines that are not displayed, are not replaced.
-

See also

Editor settings (Page 181)

4.10.3 Copying/pasting/deleting a program block

Requirement

The program is opened in the editor.

Procedure



1. Press the "Mark" softkey.

- OR -



Press the <SELECT> key.



2. Select the desired program blocks with the cursor or mouse.

3. Press the "Copy" softkey in order to copy the selection to the buffer memory.



4. Place the cursor on the desired insertion point in the program and press the "Paste" softkey.

The content of the buffer memory is pasted.

- OR -



Press the "Cut" softkey to delete the selected program blocks.

Note: When editing a program, you cannot copy or cut more than 1024 lines. While a program that is not on the NC is opened (progress display less than 100%), you cannot copy or cut more than 10 lines or insert more than 1024 characters.

Note

The buffer memory contents are retained even after the editor is closed, enabling you to paste the contents in another program, as well.

Note

Copy/cut current line

To copy and cut the current line where the cursor is positioned, it is not necessary to mark or select it. You have the option of making the "Cut" softkey only operable for marked program sections via editor settings.

See also

Opening additional programs (Page 179)

4.10.4 Renumber program

You can modify the block numbering of programs opened in the editor at a later point in time.

Requirement

The program is opened in the editor.

Procedure



1. Press the ">>" softkey.
A new vertical softkey bar appears.



2. Press the "Renumber" softkey.
The "Renumbering" window appears.

3. Enter the values for the first block number and the increment to be used for numbering.



4. Press the "OK" softkey.
The program is renumbered.

Note

If you only want to renumber a section, select the program blocks whose block numbering you want to edit.

4.10.5 Creating a program block

In order to structure programs to achieve a higher degree of transparency, you have the option of combining several blocks (G-code and/or ShopMill machining steps) to form program blocks.

You then have the option of opening and closing these blocks depending on your requirement.

Display	Meaning
Text	Block designation
Spindle	<ul style="list-style-type: none"> • S1 • S2 <p>Spindle assignment. Defines at which spindle a program block is to be executed.</p>
Addit. run-in code	<ul style="list-style-type: none"> • Yes • No <p>If the block is not executed because the specified spindle should not be processed, it is possible to temporarily activate a so-called "Addit. run-in code".</p>
Automat. retraction	<ul style="list-style-type: none"> • Yes • No <p>Block start and block end are moved to the tool change point, i.e. the tool is brought into a safe range.</p>

Structuring programs

- Before generating the actual program, generate a program frame using empty blocks.
- By forming blocks, structure existing G code or ShopMill programs.

Procedure



1. Select the "Program manager" operating area.



2. Select the storage location and create a program or open a program. The program editor opens.



3. Select the required program blocks that you wish to combine to form a block.



4. Press the "Build group" softkey.
The "Build New Group" window opens.



5. Enter a designation for the block, assign the spindle, if required, select the Addit. run-in code and the automatic retraction and then press the "OK" softkey.

Opening and closing blocks



6. Press the ">>" and "View" softkeys.



7. Press the "Open blocks" softkey if you wish to display the program with all blocks.



8. Press the "Close blocks" softkey if you wish to display the program again in a structured form.

4.10.6 Opening additional programs

You have the option of viewing and editing two programs simultaneously in the editor.

For instance, you can copy program blocks or machining steps of a program and paste them into another program.

Opening several programs

You have the option of opening up to ten program blocks.



1. In the program manager, select the programs that you wish to open and view in the multiple editor and then press on the "Open" softkey.
The editor is opened and the first two programs are displayed.



2. Press the <NEXT WINDOW> key to change to the next opened program.

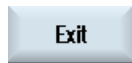

3. Press the "Close" softkey to close the actual program.

Note

Pasting program blocks

JobShop machining steps cannot be copied into a G code program.

Requirement

You have opened a program in the editor.

Procedure



1. Press the ">>" and "Open additional program" softkeys.



The "Select Additional Program" window is opened.

2. Select the program or programs that you wish to display in addition to the already opened program.

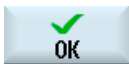

3. Press the "OK" softkey.

The editor opens and displays both programs next to each another.

See also

Copying/pasting/deleting a program block (Page 176)

4.10.7 Editor settings

Enter the default settings in the "Settings" window that are to take effect automatically when the editor is opened.

Defaults

Setting	Meaning
Number automatically	<ul style="list-style-type: none"> • Yes: A new block number will automatically be assigned after every line change. In this case, the specifications provided under "First block number" and "Increment" are applicable. • No: No automatic numbering.
First block number	Specifies the starting block number of a newly created program. The field is only editable when "Yes" is displayed under "Number automatically".
Increment	Defines the increment used for the block numbers. The field is only editable when "Yes" is displayed under "Number automatically".
Display hidden lines	<ul style="list-style-type: none"> • Yes: Hidden lines marked with "**HD" (hidden) will be displayed. • No: Lines marked with ";*HD*" will not be displayed. <p>Note: Only visible program lines are taken into account with the "Search" and "Search and Replace" functions.</p>
Display block end a symbol	The "CFLF" (line feed) symbol ¶ is displayed at the block end.
Scroll horizontally	Yes: A horizontal scrollbar is displayed. In this way, you can scroll horizontally to the end of long lines that would otherwise wrap.
Automatic save (only local and external drives)	<ul style="list-style-type: none"> • Yes: The changes are saved automatically when you change to another operating area. • No: You are prompted to save when changing to another operating area. Save or reject the changes with the "Yes" and "No" softkeys.
Visible programs	<ul style="list-style-type: none"> • 1 - 10 <p>Select how many programs can be displayed next to one another in the editor.</p> <ul style="list-style-type: none"> • Auto <p>Specifies that the number of programs entered in a job list or up to 10 selected programs will be displayed next to each other.</p>

Setting	Meaning
Width of the program with focus	Here, you enter the width of the program that has the input focus in the editor as a percentage of the window width.
Cut only after selecting	<ul style="list-style-type: none">• Yes: The cutting of program sections is possible only when program lines have been selected, i.e. the "Cut" softkey only then is active.• No: The "Cut" softkey is available by default.

Note

All entries that you make here are effective immediately.

Procedure

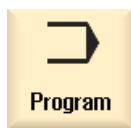

1. Select the "Program" operating area.

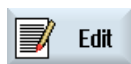

You have activated the editor.



2. Press the ">>" and "Settings" softkeys.
The "Settings" window opens.



3. Make the desired changes here and press the "OK" softkey to confirm your settings.

See also

Replacing program text (Page 174)

4.11 Display and edit user variables

4.11.1 Overview

The defined user data may be displayed in lists.

The following variables can be defined:

- Data parameters (R parameters)
- Global user data (GUD) is valid in all programs
- Local user data (LUD) is valid in one program
- Program-global user data (PUD) is valid in one program and the called subroutines.

Channel-specific user data can be defined with a different value for each channel.

Entering and displaying parameter values

Up to 15 positions (including decimal places) are evaluated. If you enter a number with more than 15 places, it will be written in exponential notation (15 places + EXXX).

LUD or PUD

Only local or program-global user data can be displayed at one time.

Whether the user data are available as LUD or PUD depends on the current control configuration.



Machine manufacturer

Please also refer to the machine manufacturer's instructions.

Note

Reading and writing variables protected

Reading and writing of user data are protected via a keyswitch and protection levels.

Searching for user data

You may search for user data within the lists using any character string.

Refer to the "Defining and activating user data" section to learn how to edit displayed user data.

4.11.2 R parameters

R parameters (arithmetic parameters) are channel-specific variables that you can use within a G code program. G code programs can read and write R parameters.

These values are retained after the controller is switched off.

Number of channel-specific R parameters

The number of channel-specific R parameters is defined in a machine data element.

Range: R0-R999 (dependent on machine data).

There are no gaps in the numbering within the range.



Machine manufacturer

Please refer to the machine manufacturer's specifications.

Procedure



1. Select the "Parameter" operating area.



2. Press the "User variable" softkey.



3. Press the "R variables" softkey.
The "R Parameters" window appears.

Delete R variables



1. Press the ">>" and "Delete" softkeys.
The "Delete R parameters" window appears.

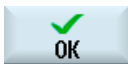

2. Enter the R parameter(s) whose channel-specific values you would like to delete and press the "OK" softkey.

A value of 0 is assigned to the selected R parameters or to all R parameters.

4.11.3 Displaying global user data (GUD)

Global user variables

Global GUDs are NC global user data (**Global User Data**) that remains available after switching the machine off.

GUDs apply in all programs.

Definition

A GUD variable is defined with the following:

- Keyword DEF
- Range of validity NCK
- Data type (INT, REAL,)
- Variable names
- Value assignment (optional)

Example

```
DEF NCK INT ZAEHLER1 = 10
```

GUDs are defined in files with the ending DEF. The following file names are reserved for this purpose:

File name	Meaning
MGUD.DEF	Definitions for global machine manufacturer data
UGUD.DEF	Definitions for global user data
GUD4.DEF	User-definable data
GUD8.DEF, GUD9.DEF	User-definable data

Procedure

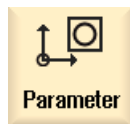

1. Select the "Parameter" operating area.



2. Press the "User variable" softkey.



3. Press the "Global GUD" softkeys.

The "Global User Variables" window is displayed. A list of the defined UGUD variables will be displayed.

- OR -



Press the "GUD selection" softkey and the "SGUD" to "GUD6" softkeys if you wish to display SGUD, MGUD, UGUD as well as GUD4 to GUD 6 of the global user variables.

- OR -



Press the "GUD selection" and ">>" softkeys as well as the "GUD7" to "GUD9" softkeys if you want to display GUD 7 to GUD 9 of the global user variables.

Note

After each start-up, a list with the defined UGUD variables is displayed in the "Global User Variables" window.

4.11.4 Displaying channel GUDs

Channel-specific user variables

Like the GUDs, channel-specific user variables are applicable in all programs for each channel. However, unlike GUDs, they have specific values.

Definition

A channel-specific GUD variable is defined with the following:

- Keyword DEF
- Range of validity CHAN
- Data type
- Variable names
- Value assignment (optional)

Example

```
DEF CHAN REAL X_POS = 100.5
```

Procedure



1. Select the "Parameter" operating area.



2. Press the "User variable" softkey.



3. Press the "Channel GUD" and "GUD selection" softkeys.



A new vertical softkey bar appears.



4. Press the "SGUD" ... "GUD6" softkeys if you want to display the SGUD, MGUD, UGUD as well as GUD4 to GUD 6 of the channel-specific user variables.



- OR -



Press the "Continue" softkey and the "GUD7" to "GUD9" softkeys if you want to display GUD 7 to GUD 9 of the channel-specific user variables.



4.11.5 Displaying local user data (LUD)

Local user variables

LUDs are only valid in the program or subprogram in which they were defined.

The controller displays the LUDs after the start of program processing. The display is available until the end of program processing.

Definition

A local user variable is defined with the following:

- Keyword DEF
- Data type
- Variable names
- Value assignment (optional)

Procedure

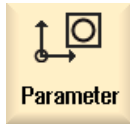

1. Select the "Parameter" operating area.



2. Press the "User variable" softkey.



3. Press the "Local LUD" softkey.

4.11.6 Displaying program user data (PUD)

Program-global user variables

PUDs are global part program variables (**Program User Data**). PUDs are valid in all main programs and subprograms, where they can also be written and read.



Machine manufacturer

Please refer to the machine manufacturer's specifications.

Procedure



1. Select the "Parameter" operating area.



2. Press the "User variable" softkey.



3. Press the "Program PUD" softkey.

4.11.7 Searching for user variables

You can search for R parameters and user variables.

Procedure

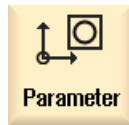

1. Select the "Parameter" operating area.



2. Press the "R parameters", "Global GUD", "Channel GUD", "Local GUD" or "Program PUD" softkeys to select the list in which you would like to search for user variables.



3. Press the "Search" softkey.
The "Search for R Parameters" or "Search for User Variables" window opens.



4. Enter the desired search term and press "OK".

The cursor is automatically positioned on the R parameter or user variables you are searching for, if they exist.

By editing a DEF/MAC file, you can alter or delete existing definition/macro files or add new ones.

Procedure

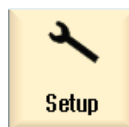

1. Select the "Start-up" operating area.



2. Press the "System data" softkey.
3. In the data tree, select the "NC data" folder and then open the "Definitions" folder.
4. Select the file you want to edit.
5. Double-click the file.



- OR -
Press the "Open" softkey.

- OR -



Press the <INPUT> key.

- OR -



Press the <Cursor right> key.

The selected file is opened in the editor and can be edited there.

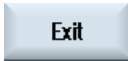

6. Define the desired user variable.
7. Press the "Exit" softkey to close the editor.

Activating user variables



1. Press the "Activate" softkey.

A prompt is displayed.

2. Select whether the current values in the definition files should be retained

- OR -

Select whether the current values in the definition files should be deleted.

This will overwrite the definition files with the initial values.



3. Press the "OK" softkey to continue the process.

4.12 Displaying G Functions and Auxiliary Functions

4.12.1 Selected G functions

16 selected G groups are displayed in the "G Function" window.

Within a G group, the G function currently active in the controller is displayed.

Some G codes (e.g. G17, G18, G19) are immediately active after switching the machine control on.

Which G codes are always active depends on the settings.



Machine manufacturer

Please refer to the machine manufacturer's specifications.

G groups displayed by default

Group	Meaning
G group 1	Modally active motion commands (e.g. G0, G1, G2, G3)
G group 2	Non-modally active motion commands, dwell time (e.g. G4, G74, G75)
G group 3	Programmable offsets, working area limitations and pole programming (e.g. TRANS, ROT, G25, G110)
G group 6	Plane selection (e.g. G17, G18)
G group 7	Tool radius compensation (e.g. G40, G42)
G group 8	Settable work offset (e.g. G54, G57, G500)
G group 9	Offset suppression (e.g. SUPA, G53)
G group 10	Exact stop - continuous-path mode (e.g. G60, G641)
G group 13	Workpiece dimensioning inches/metric (e.g. G70, G700)
G group 14	Workpiece dimensioning absolute/incremental (G90)
G group 15	Feedrate type (e.g. G93, G961, G972)
G group 16	Feedrate override on inside and outside curvature (e.g. CFC)
G group 21	Acceleration profile (e.g. SOFT, DRIVE)
G group 22	Tool offset types (e.g. CUT2D, CUT2DF)
G group 29	Radius/diameter programming (e.g. DIAMOF, DIAMCYCOF)
G group 30	Compressor ON/OFF (e.g. COMPOF)

G groups displayed by default (ISO code)

Group	Meaning
G group 1	Modally active motion commands (e.g. G0, G1, G2, G3)
G group 2	Non-modally active motion commands, dwell time (e.g. G4, G74, G75)
G group 3	Programmable offsets, working area limitations and pole programming (e.g. TRANS, ROT, G25, G110)
G group 6	Plane selection (e.g. G17, G18)
G group 7	Tool radius compensation (e.g. G40, G42)
G group 8	Settable work offset (e.g. G54, G57, G500)
G group 9	Offset suppression (e.g. SUPA, G53)
G group 10	Exact stop - continuous-path mode (e.g. G60, G641)
G group 13	Workpiece dimensioning inches/metric (e.g. G70, G700)
G group 14	Workpiece dimensioning absolute/incremental (G90)
G group 15	Feedrate type (e.g. G93, G961, G972)
G group 16	Feedrate override on inside and outside curvature (e.g. CFC)
G group 21	Acceleration profile (e.g. SOFT, DRIVE)
G group 22	Tool offset types (e.g. CUT2D, CUT2DF)
G group 29	Radius/diameter programming (e.g. DIAMOF, DIAMCYCOF)
G group 30	Compressor ON/OFF (e.g. COMPOF)

Procedure



1. Select the "Machine" operating area.



2. Press the <JOG>, <MDA> or <AUTO> key.

...



3. Press the "G functions" softkey.
The "G Functions" window is opened.



4. Press the "G functions" softkey again to hide the window.

The G groups selection displayed in the "G Functions" window may differ.

**Machine manufacturer**

Please refer to the machine manufacturer's specifications.

References

For more information about configuring the displayed G groups, refer to the following document:

SINUMERIK Operate (IM9) / SINUMERIK 840D sl Commissioning Manual

4.12.2 All G functions

All G groups and their group numbers are listed in the "G Functions" window.

Within a G group, only the G function currently active in the controller is displayed.

Additional information in the footer

The following additional information is displayed in the footer:

- Current transformations

Display	Meaning
TRANSMIT	Polar transformation active
TRACYL	Cylinder surface transformation active
TRAORI	Orientation transformation active
TRAANG	Inclined axis transformation active
TRACON	Cascaded transformation active For TRACON, two transformations (TRAANG and TRACYL or TRAANG and TRANSMIT) are activated in succession.

- Current zero offsets
- Spindle speed
- Path feedrate
- Active tool

Procedure



1. Select the "Machine" operating area.



2. Press the <JOG>, <MDA> or <AUTO> key.

...



3. Press the ">>" and "All G functions" softkeys.
The "G Functions" window is opened.



4.12.3 G functions for mold making

In the window "G functions", important information for machining free-form surfaces can be displayed using the "High Speed Settings" function (CYCLE832).



Software option

You require the "Advanced Surface" software option in order to use this function.

High-speed cutting information

In addition to the information that is provided in the "All G functions" window, the following programmed values of the following specific information is also displayed:

- CTOL
- OTOL
- STOLF

The tolerances for G0 are only displayed if they are active.

Particularly important G groups are highlighted.

You have the option to configure which G functions are highlighted.

References

- Additional information is available in the following references:
Function Manual, Basic Functions; Chapter, "Contour/orientation tolerance"
- For information about configuring the displayed G groups, refer to the following document:
Commissioning Manual SINUMERIK Operate (IM9) / SINUMERIK 840D sl

Procedure



1. Select the "Machine" operating area



2. Press the <JOG>, <MDI> or <AUTO> key.



3. Press the ">>" and "All G functions" softkeys.
The "G Functions" window is opened.

4.12.4 Auxiliary functions

Auxiliary functions include M and H functions preprogrammed by the machine manufacturer, which transfer parameters to the PLC to trigger reactions defined by the manufacturer.

Displayed auxiliary functions

Up to five current M functions and three H functions are displayed in the "Auxiliary Functions" window.

Procedure



1. Select the "Machine" operating area.



2. Press the <JOG>, <MDA> or <AUTO> key.



3. Press the "H functions" softkey.
The "Auxiliary Functions" window opens.



4. Press the "H functions" softkey again to hide the window again.

You can display status information for diagnosing synchronized actions in the "Synchronized Actions" window.

You get a list with all currently active synchronized actions.

In this list, the synchronized action programming is displayed in the same form as in the part program.

References

Programming Guide Job Planning (PGA) Chapter: Motion-synchronous actions

Status of synchronized actions

You can see the status of the synchronized actions in the "Status" column.

- Waiting
- Active
- Blocked

Non-modal synchronized actions can only be identified by their status display. They are only displayed during execution.

Synchronization types

Synchronization types	Meaning
ID=n	Modal synchronized actions in the automatic mode up to the end of program, local to program; n = 1... 254
IDS=n	Static synchronized actions, modally effective in every operating type, also beyond the end of program; n = 1... 254
Without ID/IDS	Non-modal synchronized actions in automatic mode

Note

Numbers ranging from 1 to 254 can only be assigned once, irrespective of the identification number.

Display of synchronized actions

Using softkeys, you have the option of restricting the display to activated synchronized actions.

Procedure



1. Select the "Machine" operating area.



2. Press the <AUTO>, <MDA> or <JOG> key.





...



3. Press the menu forward key and the "Synchron." softkey.
The "Synchronized Actions" window appears.
You obtain a display of all activated synchronized actions.

4. Press the "ID" softkey if you wish to hide the modal synchronized actions in the automatic mode.

- AND / OR -

Press the "IDS" softkey if you wish to hide static synchronized actions.

- AND / OR -

Press the "Blockwise" softkey if you wish to hide the non-modal synchronized actions in the automatic mode.

5. Press the "ID", "IDS" or "Blockwise" softkeys to re-display the corresponding synchronized actions.

4.13 Mold making view

For large mold making programs, as provided by CAD systems, you have the option, using a fast view, to display the machining paths. This allows you to obtain a fast overview of the program and possibly correct it.

Checking the program

For instance, you can check whether

- The programmed workpiece has the correct form (shape)
- Whether there are large traversing errors
- If yes, which block must be corrected
- How the approach and retraction are performed

Simultaneous view of the program and mold making view

In the editor, next to the program block display, switch-in the graphic view.

At the left in the editor, if you set the cursor to an NC block with position data, then this NC block is selected in the graphic view.

If you select a point to the right in the graphic view - then the NC block is selected in the left-hand part of the editor - i.e. in the other direction. This is how you jump directly to a position in the program in order to edit a program block for example.

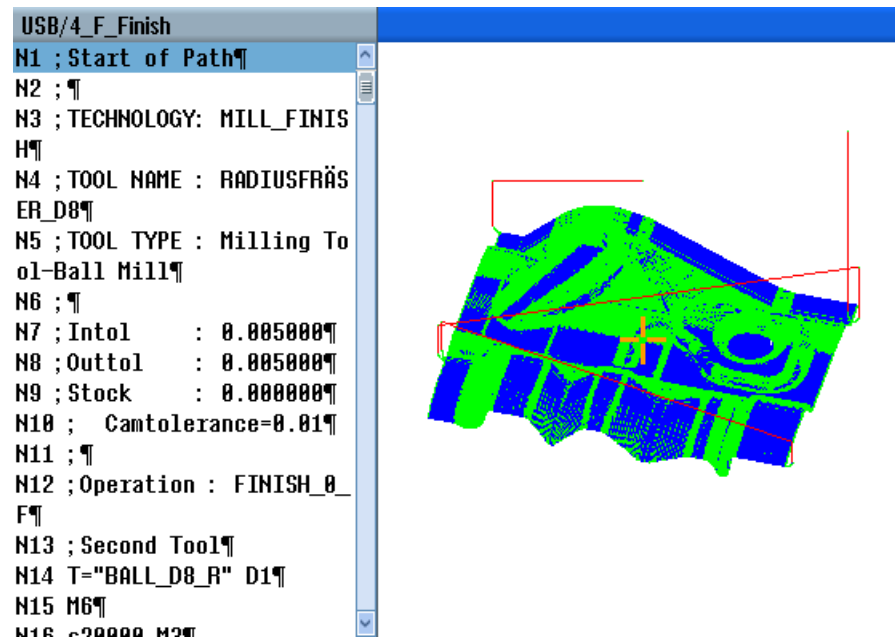

NC blocks that can be interpreted

Following NC blocks are supported for the mold building view.

- Types
 - Lines
G0, G1 with X Y Z
 - Circles
G2, G3 with center point I, J, K or radius CR, depending on the working plane G17, G18, G19, CIP with circular point I1, J1, K1 or radius CR
 - Polynomial
POLY with X, Y, Z or PO[X] PO[Y] PO[Z]
 - B-splines
BSPLINE with degree SD (SD < 6) node PL weights PW
 - Absolute data AC and incremental data IC are possible
 - For G2, G3 and different radii at the start and end, an Archimedes spiral is used
- Orientation
 - Rotary axis programming with ORIAXES or ORIVECT using ABC for G0, G1, G2, G3, CIP, POLY
 - Rotary axis programming with ORIAXES or ORIVECT using PO[A] POS[b] PO[C] for POLY
 - Orientation vector programming with ORIVECT using A3, B3, C3 for G0, G1, G2, G3, CIP
 - Orientation curve with ORICURVE using XH, YH, ZH, for G0, G1, G2, G3, CIP, POLY, BSPLINE
 - Orientation curve with ORICURVE using PO[XH] PO[YH] PO[ZH] for POLY
 - Rotary axes can be specified using DC
- G codes
 - Working planes (for circle definition G2, G3): G17 G18 G19
 - Incremental or absolute data: G90 G91

Following NC blocks are **not** supported for the mold making view.

- Helix programming
- Rational polynomials
- Other G codes or language commands

All blocks that cannot be interpreted are simply ignored

Changing and adapting the mold making view

Just the same as for simulation and simultaneous recording, you have the option of changing and adapting the simulation graphical representation in order to achieve the optimum view.

- Increasing or reducing the size of the graphic
- Moving the graphic
- Rotating the graphic
- Changing the section

4.13.1 Starting the mold making view

Procedure



1. Select the "Program manager" operating area.



2. Select the desired storage location and position the cursor on the program that you would like to display in the mold making view.



3. Press the "Open" softkey.
The program is opened in the editor.



4. Press the ">>" and "Mold making view" softkeys.
The editor splits up into two areas.

The G code blocks are displayed in the left half of the editor.

The workpiece graphic is displayed in the right half of the editor.

All of the points and paths programmed in the part program are shown in the graphical representation.



5. Press the "Graphic" softkey in order to hide the graphic and to view the program as usual in the editor

- OR -



Press the "NC blocks" softkey in order to hide the G code blocks and therefore only to display the graphic.

4.13.2 Specifically jump to the program block

If you notice anything peculiar in the graphic or identify an error, then from this location, you can directly jump to the program block involved to possibly edit the program.

Preconditions

- The required program is opened in the mold making view.
- The "Graphic" softkey is active.

Procedure



1. Press the ">>" and "Select point" softkeys.
Cross-hairs for selecting a point is shown in the diagram.



2. Using the cursor keys, move the cross-hairs to the appropriate position in the graphic.



3. Press the "Select NC block" softkey.
The cursor jumps to the associated program block in the editor.

4.13.3 Searching for program blocks

Using the "Search" function, you can search for specific program blocks as well as edit programs; you can do this in one step by replacing the text that you are searching for by a new text.

Precondition

- The required program is opened in the mold making view.
- The "NC blocks" softkey is active.

Procedure



1. Press the "Search" softkey.
A new vertical softkey bar appears.

See also

- Searching in programs (Page 173)
- Replacing program text (Page 174)

4.13.4 Changing the view

4.13.4.1 Enlarging or reducing the graphical representation

Precondition

- The mold making view has been started.
- The "Graphic" softkey is active.

Procedure



...



1. Press the <+> and <-> keys if you wish to enlarge or reduce the graphic display.
The graphic display enlarged or reduced from the center.



- OR -

Press the "Details" and "Zoom +" softkeys if you wish to increase the size of the segment.



- OR -

Press the "Details" and "Zoom -" softkeys if you wish to decrease the size of the segment.



- OR -

Press the "Details" and "Auto zoom" softkeys if you wish to automatically adapt the segment to the size of the window.

The automatic scaling function "Fit to size" takes account of the largest expansion of the workpiece in the individual axes.

Note

Selected section

The selected sections and size changes are kept as long as the program is selected.

4.13.4.2 Modifying the viewport

Use the magnifying glass if you would like to move, increase or reduce the size of the section of the mold making view, e.g. to view details or display the complete workpiece.

Using the magnifying glass, you can define your own segment and then increase or decrease its size.

Precondition

- The mold making view has been started.
- The "Graphic" softkey is active.

Procedure



1. Press the "Details" softkey.



2. Press the "Zoom" softkey.

A magnifying glass in the shape of a rectangular frame appears.



3. Press the "Magnify +" or <+> softkey to enlarge the frame.

- OR -



Press the "Magnify -" or <-> softkey to reduce the frame.

- OR -



Press one of the cursor keys to move the frame up, down, left or right.



4. Press the "Accept" softkey to accept the section.

4.14 Displaying the program runtime and counting workpieces

To gain an overview of the program runtime and the number of machined workpieces, open the "Times, Counter" window.



Machine manufacturer

Please refer to the machine manufacturer's specifications.

Displayed times

- Program
Pressing the softkey the first time shows how long the program has already been running.
At every further start of the program, the time required to run the entire program the first time is displayed.
If the program or the feedrate is changed, the new program runtime is corrected after the first run.
- Program remainder
Here you can see how long the current program still has to run. In addition, you can track how much of the current program has been completed as a percentage by using the progress bar.
The display only appears when the program is run a second time.
If you are executing the program from an external location, the program loading progress is displayed here.
- Influencing the time measurement
The time measurement is started with the start of the program and ends with the end of the program (M30) or with an agreed M function.
When the program is running, the time measurement is interrupted with CYCLE STOP and continued with CYCLE START.
The time measurement starts at the beginning with RESET and subsequent CYCLE START.
The time measurement stops with CYCLE STOP or a feedrate override = 0.

Counting workpieces

You can also display program repetitions and the number of completed workpieces. For the workpiece count, enter the actual and planned workpiece numbers.

Workpiece count

Completed workpieces can be counted via the end of program command (M30) or an M command.

Procedure



1. Select the "Machine" operating area.



2. Press the <AUTO> key.



3. Press the "Times, Counter" softkey.
The "Times, Counter" window opens.



4. Select "Yes" under "Count workpieces" if you want to count completed workpieces.

5. Enter the number of workpieces needed in the "Desired workpieces" field.

The number of workpieces already finished is displayed in "Actual workpieces". This value can be corrected if necessary.

After the defined number of workpieces is reached, the current workpieces display is automatically reset to zero.

See also

Specifying the number of workpieces (Page 268)

4.15 Setting for automatic mode

Before machining a workpiece, you can test the program in order to identify programming errors early on. Use the dry run feedrate for this purpose.

In addition, you have the option of additionally limiting the traversing speed for rapid traverse so that when running-in a new program with rapid traverse, no undesirable high traversing speeds occur.

Dry run feedrate

The feedrate defined here replaces the programmed feedrate during execution if you have selected "DRY run feedrate" under program control.

Reduced rapid traverse

This value entered here reduces the rapid traverse to the entered percentage value if you selected "RG0 reduced rapid traverse" under program control.

Displaying measurement results

Using an MMC command, you can display measurement results in a part program:

You can define the following settings:

- When it reaches the command, the control automatically jumps to the "Machine" operating area and the window with the measurement results is displayed
- The window with the measurement results is opened by pressing the "Measurement result" softkey.

Procedure



1. Select the "Machine" operating area.



2. Press the <AUTO> key.



3. Press the menu forward key and the "Settings" softkey.
The "Settings for Automatic Operation" window is opened.



4. In "DRY run feedrate," enter the desired dry run speed.



5. Enter the desired percentage in the "Reduced rapid traverse RG0" field. RG0 has not effect if you do not change the specified amount of 100%.
6. Enter "Automatic" in the "Display measurement result" box if the measurement result window should be automatically opened, or "Manual", if the measurement result window should be opened by pressing the "Measurement result" softkey.

References

Programming Manual Measuring Cycles / 840D sl/828D

Note

The feedrate can be changed while the operation is running.

Machine references

The simulation is implemented as workpiece simulation. This means that it is not assumed that the zero offset has already been precisely scratched or is known.

In spite of this, unavoidable machine references are in the programming, such as for example, the tool change point in the machine, the retraction position when swiveling and the table components of a swivel kinematic. Depending on the actual zero offset - in the worst case - these machine references can mean that collisions are shown in the simulation that would not occur for a realistic zero offset - or vice versa, collisions are not shown, which could occur for a realistic zero offset.

Programmable frames

All frames and zero offsets are taken into account in the simulation.

Note

Manually swiveled axes

Note that swivel movement in simulation and during simultaneous recording is also displayed when the axes are swiveled manually at the start.

Simulation display

You can choose one of the following types of display:

- Material removal simulation

During simulation or simultaneous recording you can follow stock removal from the defined blank.

- Path display

You have the option of including the display of the path. The programmed tool path is displayed.

Note

Tool display in the simulation and for simultaneous recording

In order that workpiece simulation is also possible for tools that have either not been measured or have been incompletely entered, certain assumptions are made regarding the tool geometry.

For instance, the length of a miller or drill is set to a value proportional to the tool radius so that cutting can be simulated.

Note

Thread turns not displayed

For thread and drill thread milling, the thread turns are not displayed in the simulation and for simultaneous recording.

Display variants

You can choose between three variants of graphical display:

- Simulation before machining of the workpiece
Before machining the workpiece on the machine, you can perform a quick run-through in order to graphically display how the program will be executed.
- Simultaneous recording before machining of the workpiece
Before machining the workpiece on the machine, you can graphically display how the program will be executed during the program test and dry run feedrate. The machine axes do not move if you have selected "no axis motion".
- Simultaneous recording during machining of the workpiece
You can follow machining of the workpiece on the screen while the program is being executed on the machine.

Views

The following views are available for all three variants:

- Top view
- 3D view
- Side views

Status display

The current axis coordinates, the override, the current tool with cutting edge, the current program block, the feedrate and the machining time are displayed.

In all views, a clock is displayed during graphical processing. The machining time is displayed in hours, minutes and seconds. It is approximately equal to the time that the program requires for processing including the tool change.



Software options

You require the option "3D simulation of the finished part" for the 3D view.

You require the option "Simultaneous recording (real-time simulation)" for the "Simultaneous recording" function.

Determining the program runtime

The program runtime is determined when executing the simulation. The program runtime is temporarily displayed in the editor at the end of the program.

Properties of simultaneous recording and simulation

Traversing paths

For the simulation, the displayed traversing paths are saved in a ring buffer. If this buffer is full, then the oldest traversing path is deleted with each new traversing path.

Optimum display

If simultaneous machining is stopped or has been completed, then the display is again converted into a high-resolution screen. In some cases this is not possible. In this case, the following message is output: "High-resolution image cannot be generated".

Working zone limitation

No working zone limits and software limit switches are effective in the tool simulation.

Start position for simulation and simultaneous recording

During simulation, the start position is converted via the zero offset to the workpiece coordinate system.

The simultaneous recording starts at the position at which the machine is currently located.

Restrictions

- Traori: 5-axis motion is linearly interpolated. More complex motion cannot be displayed.
- Referencing: G74 from a program run does not function.
- Alarm 15110 "REORG block not possible" is not displayed.
- Compile cycles are only partly supported.
- No PLC support.
- Axis containers are not supported.

Supplementary conditions

- All of the existing data records (Toolcarrier / TRAORI, TRACYL) are evaluated and must be correctly commissioned for correct simulation.
- Transformations with swiveled linear axis (TRAORI 64 - 69) as well as OEM transformations (TRAORI 4096 - 4098) are not supported.
- Changes to the toolcarrier or transformation data only become effective after Power On.
- Transformation change and swivel data record change are supported. However, a real kinematic change is not supported, where a swivel head is physically changed.
- The simulation of mold making programs with extremely short block change times can take longer than machining, as the computation time distribution for this application is dimensioned in favor of the machining and to the detriment of simulation.

Examples

Several examples for machine types that are supported:

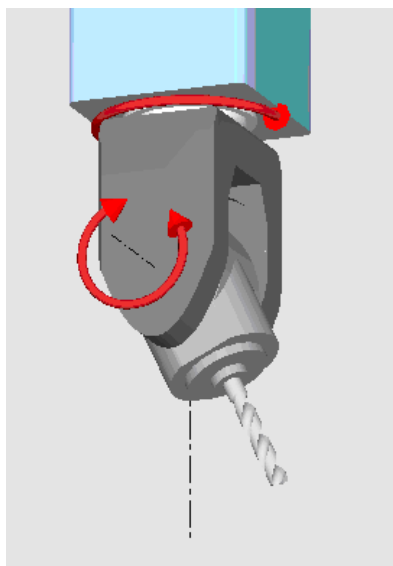

Swivel head 90°/90°

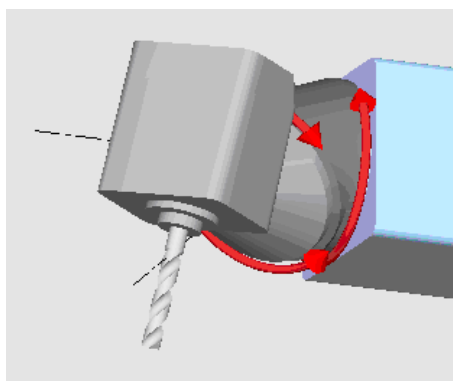

Swivel head 90°/45°

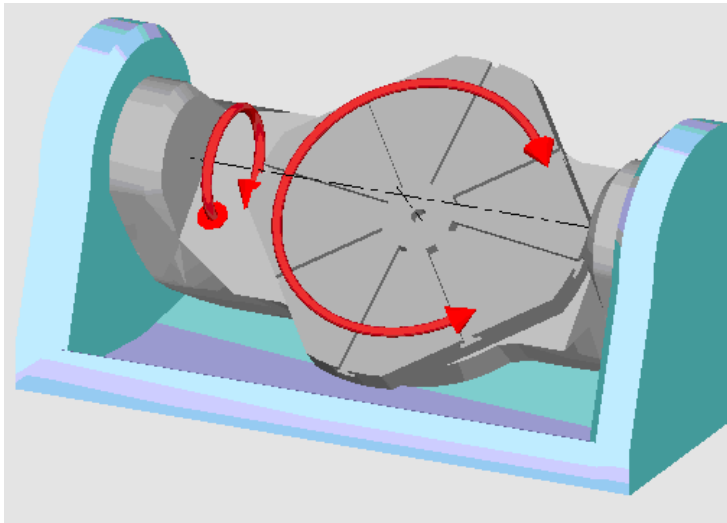

Swivel table 90°/90°

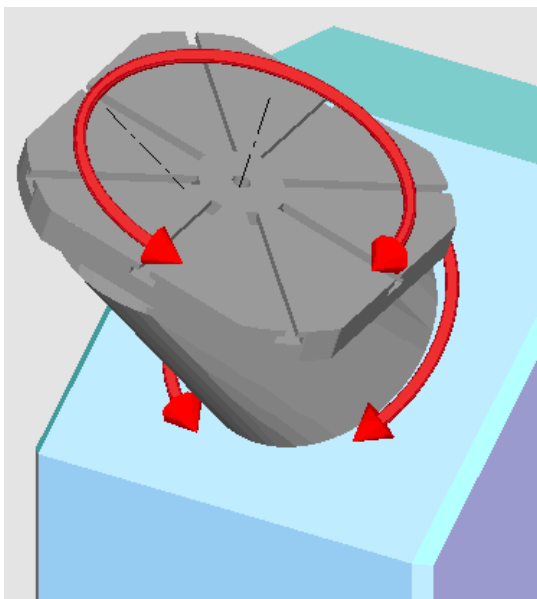

Swivel table 90°/45°

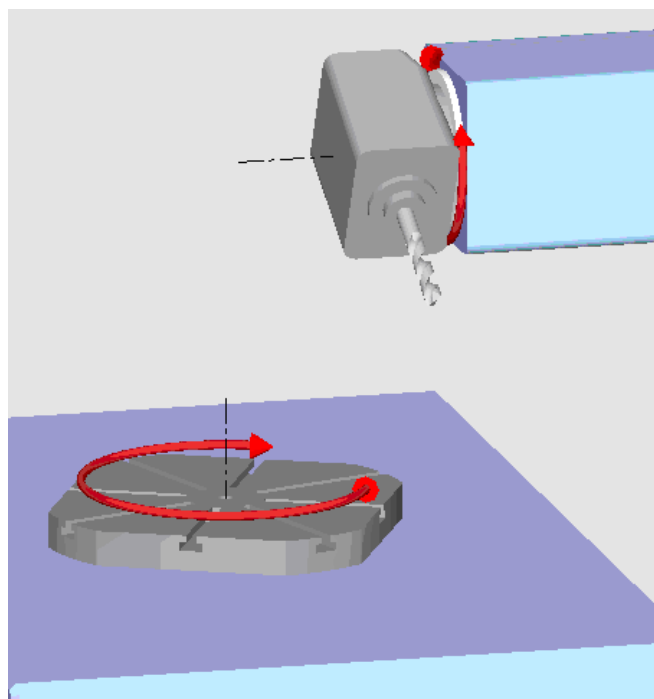

Swivel combination 90°/90°

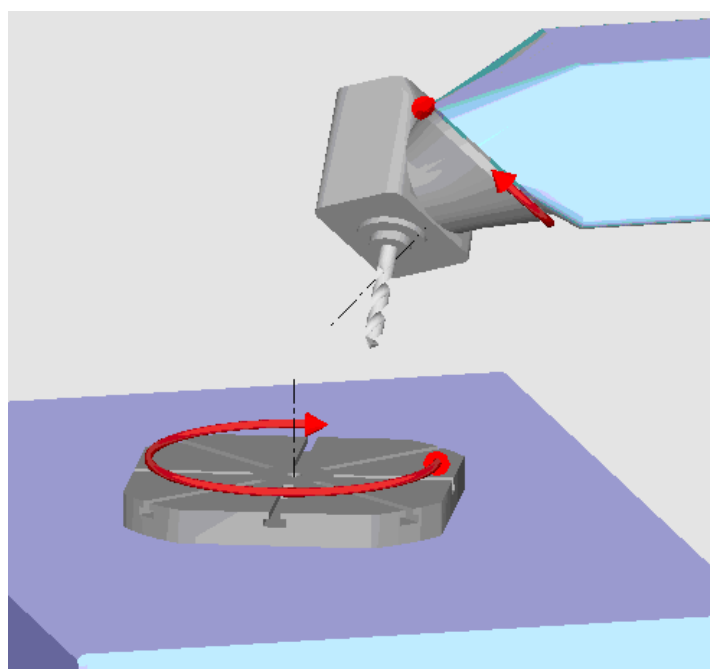

Swivel combination 45°/90°

5.2 Simulation before machining of the workpiece

Before machining the workpiece on the machine, you have the option of performing a quick run-through in order to graphically display how the program will be executed. This provides a simple way of checking the result of the programming.

Feedrate override

Feedrate override is also active during simulation.

You can change the feedrate during the simulation via the user interface.

0 %: The simulation stops.

100 %: The program is executed as quickly as possible.

Procedure



1. Select the "Program Manager" operating area.



2. Select the storage location and position the cursor on the program to be simulated.
3. Press the <INPUT> or <Cursor right> key.



- OR -

Double-click the program.

The selected program is opened in the "Program" operating area.



4. Press the "Simulation" softkey.

The program execution is displayed graphically on the screen. The machine axes do not move.



5. Press the "Stop" softkey if you wish to stop the simulation.

- OR -

Press the "Reset" softkey to cancel the simulation.



6. Press the "Start" softkey to restart or continue the simulation.



Note**Operating area switchover**

The simulation is exited if you switch into another operating area. If you restart the simulation, then this starts again at the beginning of the program.

5.3 Simultaneous recording before machining of the workpiece

Before machining the workpiece on the machine, you can graphically display the execution of the program on the screen to monitor the result of the programming.

**Software option**

You require the option "Simultaneous recording (real-time simulation)" for the simultaneous recording.

You can replace the programmed feedrate with a dry run feedrate to influence the speed of execution and select the program test to disable axis motion.

If you would like to view the current program blocks again instead of the graphical display, you can switch to the program view.

Procedure

1. Load a program in the "AUTO" mode.
2. Press the "Prog. ctrl." softkey and activate the checkboxes "PRT no axis movement" and "DRY run feedrate".

The program is executed without axis movement. The programmed feedrate is replaced by a dry run feedrate.



3. Press the "Sim. rec." softkey.



4. Press the <CYCLE START> key.

The program execution is displayed graphically on the screen.



5. Press the "Sim. rec." softkey again to stop the recording.

5.4 Simultaneous recording during machining of the workpiece

If the view of the work space is blocked by coolant, for example, while the workpiece is being machined, you can also track the program execution on the screen.



Software option

You require the option "Simultaneous recording (real-time simulation)" for the simultaneous recording.

Procedure



1. Load a program in the "AUTO" mode.
2. Press the "Sim. rec." softkey.



3. Press the <CYCLE START> key.
The machining of the workpiece is started and graphically displayed on the screen.



4. Press the "Sim. rec." softkey again to stop the recording.

Note

- If you switch-on simultaneous recording after the unmachined part information has already been processed in the program, only traversing paths and tool are displayed.
 - If you switch-off simultaneous recording during machining and then switch-on the function again at a later time, then the traversing paths generated in the intermediate time will not be displayed.
-

5.5 Different views of the workpiece

In the graphical display, you can choose between different views so that you constantly have the best view of the current workpiece machining, or in order to display details or the overall view of the finished workpiece.

The following views are available:

- Top view
- 3D view
- Side views

5.5.1 Plan view



1. Start the simulation.
2. Press the "Top view" softkey.
The workpiece is shown from above in the top view.

Changing the display

You can increase or decrease the size of the simulation graphic and move it, as well as change the segment.

5.5.2 3D view



1. Start the simulation.
2. Press the "Other views" and "3D view" softkeys.



Software option

You require the option "3D simulation (finished part)" for the simulation.

Changing the display

You can increase or decrease the size of the simulation graphic, move it, turn it, or change the segment.

Displaying and moving cutting planes

You can display and move cutting planes X, Y, and Z.

See also

Defining cutting planes (Page 227)

5.5.3 Side view



1. Starting the simulation.
2. Press the "Other views" softkey.



3. Press the "From front" softkey if you wish to view the workpiece from the front.

- OR -



Press the "From rear" softkey if you wish to view the workpiece from the rear.

- OR -



Press the "From left" softkey if you wish to view the workpiece from the left.

- OR -



Press the "From right" softkey if you wish to view the workpiece from the right.

Changing the display

You can increase or decrease the size of the simulation graphic and move it, as well as change the segment.

5.6 Editing the simulation display

5.6.1 Blank display

You have the option of replacing the blank defined in the program or to define a blank for programs in which a blank definition cannot be inserted.

Note

The unmachined part can only be entered if simulation or simultaneous recording is in the reset state.

Procedure



1. The simulation or the simultaneous recording is started.
2. Press the ">>" and "Blank" softkeys.
The "Blank Input" windows opens and displays the pre-assigned values.
3. Enter the desired values for the dimensions.
4. Press the "Accept" softkey to confirm your entries. The newly defined workpiece is displayed.

5.6.2 Showing and hiding the tool path

The path display follows the programmed tool path of the selected program. The path is continuously updated as a function of the tool movement. The tool paths can be shown or hidden as required.

Procedure



1. The simulation or the simultaneous recording is started.
2. Press the ">>" softkey.
The tool paths are displayed in the active view.
3. Press the softkey to hide the tool paths.
The tool paths are still generated in the background and can be shown again by pressing the softkey again.
4. Press the "Delete tool path" softkey.
All of the tool paths recorded up until now are deleted.

5.7 Program control during the simulation

5.7.1 Changing the feedrate



You can change the feedrate at any time during the simulation.

You can track the changes in the status line.

Note

If you are working with the "Simultaneous recording" function, the rotary switch (override) on the control panel is used.

Procedure



1. Simulation is started.
2. Press the "Program control" softkey.

3. Press the "Override +" or "Override -" softkey to increase or decrease the feedrate by 5%.



- OR -
Press the "Override 100%" softkey to set the feedrate to the maximum value.

- OR -
Press the "<<" softkey to return to the main screen and perform the simulation with changed feedrate.

Note







Toggle between "Override +" and "Override -"

-  Press the <CTRL> and <Cursor down> or <Cursor up> keys to toggle between the "Override +" and "Override -" softkeys.
-  

5.7.2 Simulating the program block by block



You can control the program execution during simulation, i.e. execute a program block by block, as when executing a program.

Procedure

- | | |
|---|--|
| | 1. Simulation is started. |
|  | 2. Press the "Program control" and "Single block" softkeys. |
|  | |
|  | 3. Press the "Back" and "Start SBL" softkeys. |
|  | The pending block of the program is simulated and then stops. |
|  | 4. Press "Start SBL" as many times as you want to simulate a single program block. |
|  | 5. Press the "Program control" and the "Single block" softkeys to exist the single block mode. |
|  | |

Note

Enabling/disabling single block

- | | |
|---|---|
|  | Press the <CTRL> and <S> keys simultaneously to enable and disable the single block mode. |
| + | |
|  | |

5.8 Changing and adapting a simulation graphic

5.8.1 Enlarging or reducing the graphical representation

Precondition

The simulation or the simultaneous recording is started.

Procedure



...



1. Press the <+> and <-> keys if you wish to enlarge or reduce the graphic display.
The graphic display enlarged or reduced from the center.

- OR -



Press the "Details" and "Zoom +" softkeys if you wish to increase the size of the segment.

- OR -



Press the "Details" and "Zoom -" softkeys if you wish to decrease the size of the segment.

- OR -



Press the "Details" and "Auto zoom" softkeys if you wish to automatically adapt the segment to the size of the window.

The automatic scaling function "Fit to size" takes account of the largest expansion of the workpiece in the individual axes.

Note

Selected section

The selected sections and size changes are kept as long as the program is selected.

5.8.2 Panning a graphical representation

Precondition

The simulation or the simultaneous recording is started.

Procedure



1. Press a cursor key if you wish to move the graphic up, down, left, or right.



5.8.3 Rotating the graphical representation

In the 3D view you can rotate the position of the workpiece to view it from all sides.

Precondition

Simulation has been started and the 3D view is selected.

Procedure



1. Press the "Details" softkey.



2. Press the "Rotate view" softkey.



...



...



2. Press the "Arrow right", "Arrow left", "Arrow up", "Arrow down", "Arrow clockwise" and "Arrow counterclockwise" softkeys to change the position of the workpiece.

- OR -

Keep the <Shift> key pressed and then turn the workpiece in the desired direction using the appropriate cursor keys.

5.8.4 Modifying the viewport

If you would like to move, enlarge or decrease the size of the segment of the graphical display, e.g. to view details or display the complete workpiece, use the magnifying glass.

Using the magnifying glass, you can define your own segment and then increase or decrease its size.

Precondition

The simulation or the simultaneous recording is started.

Procedure



1. Press the "Details" softkey.
2. Press the "Magnifying glass" softkey. A magnifying glass in the shape of a rectangular frame appears.
3. Press the "Magnify +" or <+> softkey to enlarge the frame.

- OR -

Press the "Magnify -" or <-> softkey to reduce the frame.

- OR -



Press one of the cursor keys to move the frame up, down, left or right.

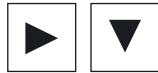

4. Press the "Accept" softkey to accept the section.

5.8.5 Defining cutting planes

In the 3D view, you have the option of "cutting" the workpiece and therefore displaying certain views in order to show hidden contours.

Precondition

The simulation or the simultaneous recording is started.

Procedure



1. Press the "Details" softkey.



2. Press the "Cut" softkey.



The workpiece is displayed in the cut state.

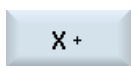

3. Press the corresponding softkey to shift the cutting plane in the required direction.

...

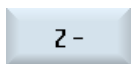

5.9 Displaying simulation alarms

Alarms might occur during simulation. If an alarm occurs during a simulation run, a window opens in the operating window to display it.

The alarm overview contains the following information:

- Date and time
- Deletion criterion
Specifies with which softkey the alarm is acknowledged
- Alarm number
- Alarm text

Precondition

Simulation is running and an alarm is active.

Procedure



1. Press the "Program control" and "Alarm" softkeys.
The "Simulation Alarms" window is opened and a list of all pending alarms is displayed.

Press the "Acknowledge alarm" softkey to reset the simulation alarms indicated by the Reset or Cancel symbol.
The simulation can be continued.
- OR -
Press the "Simulation Power On" softkey to reset a simulation alarm indicated by the Power On symbol.

Generating a G code program

6.1 Graphical programming

Functions

The following functionality is available:

- Technology-oriented program step selection (cycles) using softkeys
- Input windows for parameter assignment with animated help screens
- Context-sensitive online help for every input window
- Support with contour input (geometry processor)

Call and return conditions

- The G functions active before the cycle call and the programmable frame remain active beyond the cycle.
- The starting position must be approached in the higher-level program before the cycle is called. The coordinates are programmed in a clockwise coordinate system.

6.2 Program views

You can display a G code program in various ways.

- Program view
- Parameter screen, either with help screen or graphic view

Program view

The program view in the editor provides an overview of the individual machining steps of a program.

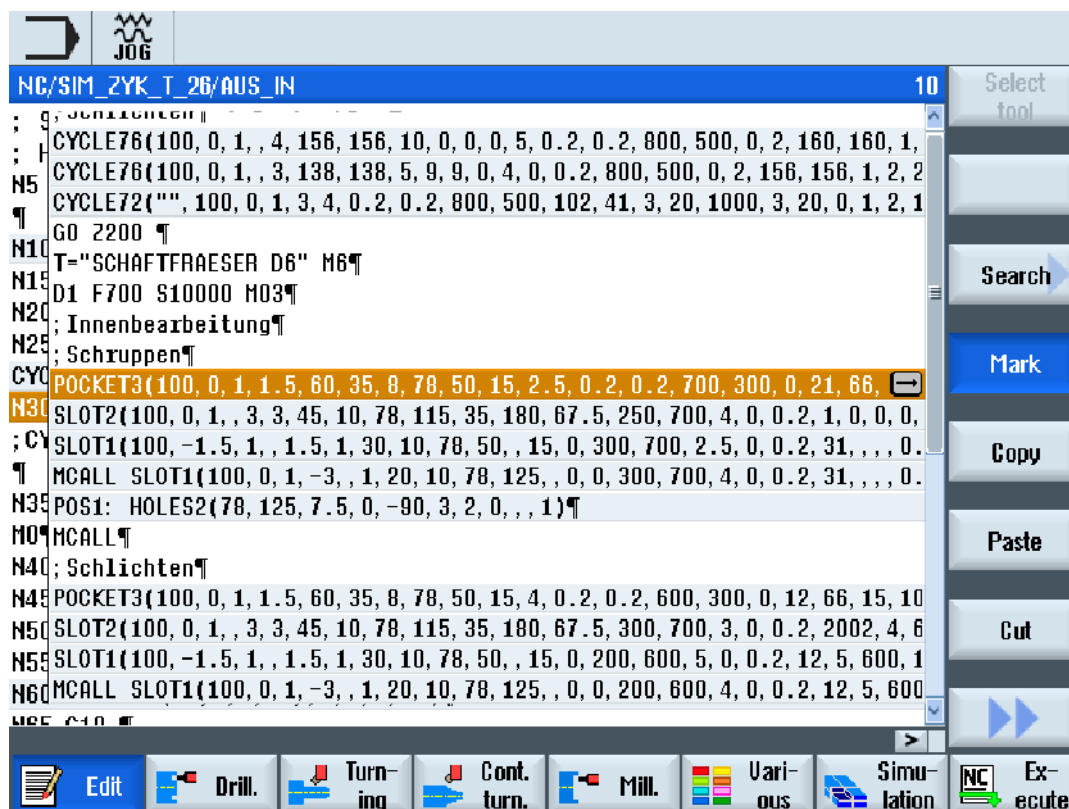

Figure 6-1 Program view of a G code program



In the program view, you can move between the program blocks using the <Cursor up> and <Cursor down> keys.



Parameter screen with help display



Press the <Cursor right> key to open a selected program block or cycle in the program view.

The associated parameter screen with help screen is then displayed.

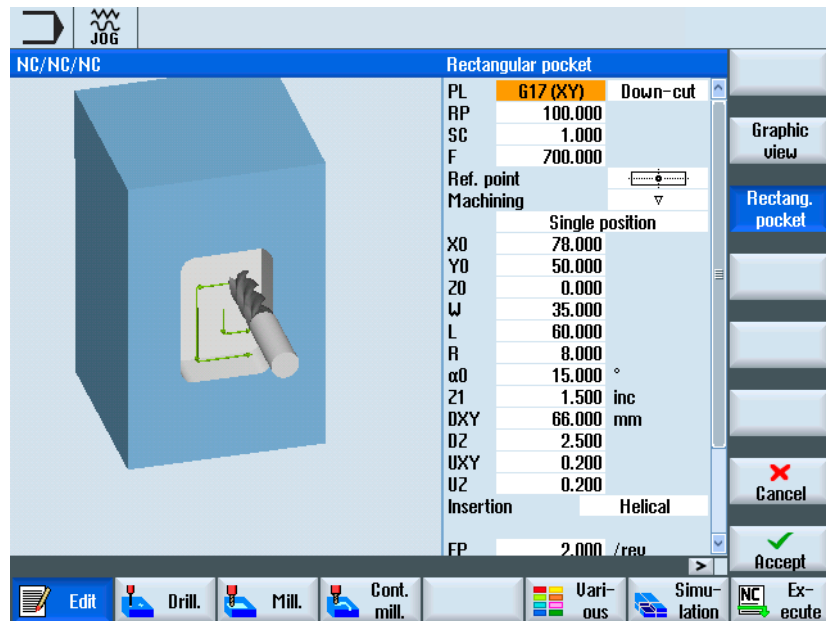

Figure 6-2 Parameter screen with help display

The animated help displays are always displayed with the correct orientation to the selected coordinate system. The parameters are dynamically displayed in the graphic. The selected parameter is displayed highlighted in the graphic.

The color symbols

Red arrow = tool traverses in rapid traverse

Green arrow = tool moves with the machining feedrate

Parameter screen with graphic view



Using the "Graphic view" softkey, you can toggle between the help screen and the graphic view in the screen.

Note

Switching between the help screen and the graphic view

The key combination <CTRL> + <G> is also available for the switchover between the help screen and the graphic view.

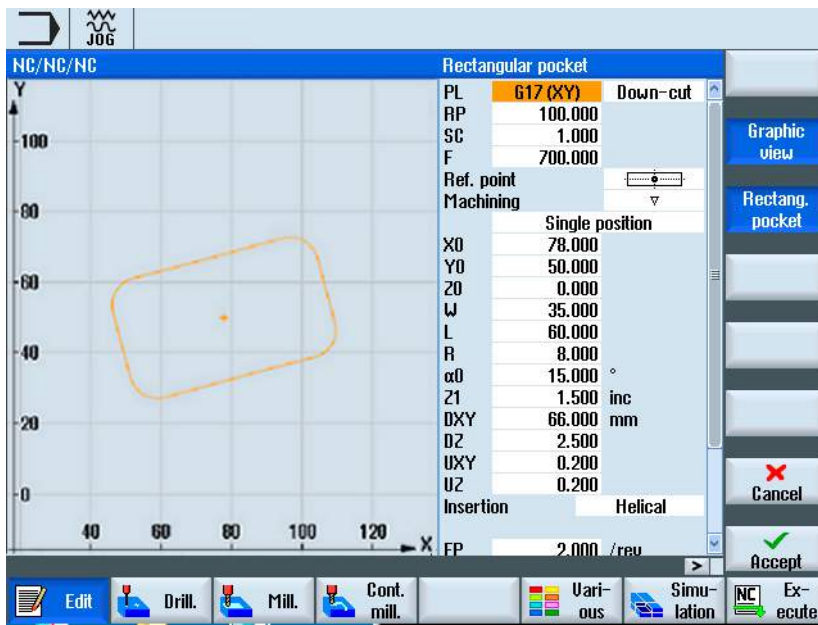

Figure 6-3 Parameter screen with a graphical view of a G code program block

6.3 Program structure

G_code programs can always be freely programmed. The most important commands that are included in the rule:

- Set a machining plane
- Call a tool (T and D)
- Call a work offset
- Technology values such as feedrate (F), feedrate type (G94, G95,...), speed and direction of rotation of the spindle (S and M)
- Positions and calls, technology functions (cycles)
- End of program

For G code programs, before calling cycles, a tool must be selected and the required technology values F, S programmed.

A blank can be specified for simulation.

See also

Blank input (Page 238)

6.4 Fundamentals

6.4.1 Machining planes

A plane is defined by means of two coordinate axes. The third coordinate axis (tool axis) is perpendicular to this plane and determines the infeed direction of the tool (e.g. for 2½-D machining).

When programming, it is necessary to specify the working plane so that the control system can calculate the tool offset values correctly. The plane is also relevant to certain types of circular programming and polar coordinates.

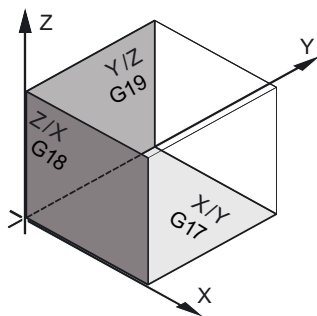

Working planes

Working planes are defined as follows:

Plane		Tool axis
X/Y	G17	Z
Z/X	G18	Y
Y/Z	G19	X

6.4.2 Current planes in cycles and input screens

Each input screen has a selection box for the planes, if the planes have not been specified by NC machine data.

- Empty (for compatibility reasons to screen forms without plane)
- G17 (XY)
- G18 (ZX)
- G19 (YZ)

There are parameters in the cycle screens whose names depend on this plane setting. These are usually parameters that refer to positions of the axes, such as reference point of a position pattern in the plane or depth specification when drilling in the tool axis.

For G17, reference points in the plane are called X0 Y0, for G18 they are called Z0 X0 - and for G19, they are called Y0 Z0. The depth specification in the tool axis for G17 is called Z1, for G18, Y1 and for G19, X1.

If the entry field remains empty, the parameters, the help screens and the broken-line graphics are displayed in the default plane (can be set via machine data):



- Turning: G18 (ZX)
- Milling: G17 (XY)

The plane is transferred to the cycles as new parameter. The plane is output in the cycle, i.e. the cycle runs in the entered plane. It is also possible to leave the plane fields empty and thus create a plane-independent program.

The entered plane only applies for this cycle (not modal)! At the end of the cycle, the plane from the main program applies again. In this way, a new cycle can be inserted in a program without having to change the plane for the remaining program.

6.4.3 Programming a tool (T)

Calling a tool

1. You are in a part program
2. Press the "Select tool" softkey.
 The "Tool selection" window is opened.
3. Position the cursor on the desired tool and press the "To program" softkey.
 The selected tool is loaded into the G code editor. Text such as the following is displayed at the current cursor position in the G code editor:
 T="ROUGHINGTOOL100"
 - OR -



4. Press the "Tool list" and "New tool" softkeys.
5. Then select the required tool using the softkeys on the vertical softkey bar, parameterize it and then press the softkey "To program".
The selected tool is loaded into the G code editor.
6. Then program the tool change (M6), the spindle direction (M3/M4), the spindle speed (S...), the feedrate (F), the feedrate type (G94, G95,...), the coolant (M7/M8) and, if required, further tool-specific functions.

6.5 Generating a G code program

Create a separate program for each new workpiece that you would like to produce. The program contains the individual machining steps that must be performed to produce the workpiece.

Part programs in the G code can be created under the "Workpiece" folder or under the "Part programs" folder.

Procedure



1. Select the "Program Manager" operating area.



2. Select the required archiving location.

Creating a new part program



3. Position the cursor on the folder "Part programs" and press the "New" softkey.



The "New G Code Program" window opens.



4. Enter the required name and press the "OK" softkey.
The name can contain up to 28 characters (name + dot + 3-character extension). You can use any letters (except accented), digits or the underscore symbol (_).

The program type (MPF) is set by default.

The project is created and opened in the Editor.

Creating a new part program for a workpiece



5. Position the cursor on the folder "Workpieces" and press the "New" softkey.



The "New G Code Program" window opens.



6. Select the file type (MPF or SPF), enter the desired name of the program and press the "OK" softkey.

The project is created and opened in the Editor.

7. Enter the desired G code commands.

See also

Changing a cycle call (Page 247)

Creating a new workpiece (Page 582)

6.6 Blank input

Function

The blank is used for the simulation and the simultaneous recording. A useful simulation can only be achieved with a blank that is as close as possible to the real blank.

Create a separate program for each new workpiece that you would like to produce. The program contains the individual machining steps that are performed to produce the workpiece.

For the blank of the workpiece, define the shape (cuboid, tube, cylinder, polygon or centered cuboid) and your dimensions.

Manually reclamping the blank

If the blank is to be manually reclamped from the main spindle to the counterspindle for example, then delete the blank.

Example

- Blank, main spindle, cylinder
- Machining
- M0 ; Manually reclamping the blank
- Blank, main spindle, delete
- Blank, counterspindle, cylinder
- Machining

The blank entry always refers to the work offset currently effective at the position in the program.

Note

Swiveling

For programs that use "Swiveling", a 0 swivel must first be made and then the blank defined.

Procedure









1. Select the "Program" operating area.





2. Press the "Misc." and "Blank" softkeys.
The "Blank Input" window opens.



Parameters	Description	Unit
Data for	Selection of the spindle for blank <ul style="list-style-type: none"> • Main spindle • Counterspindle Note: If the machine does not have a counterspindle, then the entry field "Data for" is not applicable.	
Blank 	Selecting the blank <ul style="list-style-type: none"> • Cuboid • Tube • Cylinder • Polygon • Centered cuboid • Delete 	
X0	1. Rectangular point X - (only for cuboid)	
Y0	1. Rectangular point Y - (only for cuboid)	
X1 	2. Rectangular point X (abs) or 2nd rectangular point X referred to X0 (inc) - (only for cuboid)	
Y1 	2. Rectangular point Y (abs) or 2nd rectangular point Y referred to Y0 (inc) - (only for cuboid)	
ZA	Initial dimension	
ZI 	Final dimension (abs) or final dimension in relation to ZA (inc)	
ZB 	Machining dimension (abs) or machining dimension in relation to ZA (inc)	
XA	Outside diameter – (only for tube and cylinder)	mm
XI 	Inside diameter (abs) or wall thickness (inc) – (only for tube)	mm
N	Number of edges – (only for polygon)	
SW or L 	Width across flats or edge length – (only for polygon)	
W	Width of the blank - (only for centered cuboid)	mm
L	Length of the blank - (only for centered cuboid)	mm

6.7 Machining plane, milling direction, retraction plane, safe clearance and feedrate (PL, RP, SC, F)

In the program header, cycle input screens have general parameters that are always repeated. You will find the following parameters in every input screen for a cycle in a G code program.

Parameter	Description	Unit
PL 	Each input screen has a selection box for the planes, if the planes have not been specified by NC machine data. Machining plane: <ul style="list-style-type: none"> • G17 (XY) • G18 (ZX) • G19 (YZ) 	
Milling direction 	When milling, the machining direction of rotation (climbing or conventional) and the spindle direction of rotation in the tool list are taken into consideration. The pocket is then machined in a clockwise or counterclockwise direction. During path milling, the programmed contour direction determines the machining direction.	
RP	Retraction plane (abs) During machining the tool travels in rapid traverse from the tool change point to the return plane and then to the safety clearance. The machining feedrate is activated at this level. When the machining operation is finished, the tool travels at the machining feedrate away from the workpiece to the safety clearance level. It travels from the safety clearance to the retraction plane and then to the tool change point in rapid traverse. The retraction plane is entered as an absolute value. Normally, reference point Z0 and retraction plane RP have different values. The cycle assumes that the retraction plane is in front of the reference point.	mm
SC 	Safety clearance (inc) Acts in relation to the reference point. The direction in which the safety clearance is effective is automatically determined by the cycle. The safety clearance must be entered as an incremental value (without sign).	mm
F	Feedrate The feedrate F (also referred to as the machining feedrate) specifies the speed at which the axes move during machining of the workpiece. The unit of the feedrate (mm/min, mm/rev, mm/tooth etc.) always refers to the feedrate type programmed before the cycle call. The maximum feedrate is determined via machine data.	

6.8 Selection of the cycles via softkey

Overview of machining steps

The following softkey bars are available to insert machining steps.

All of the cycles/functions available in the control are shown in this display. However, at a specific system, only the steps possible corresponding to the selected technology can be selected.

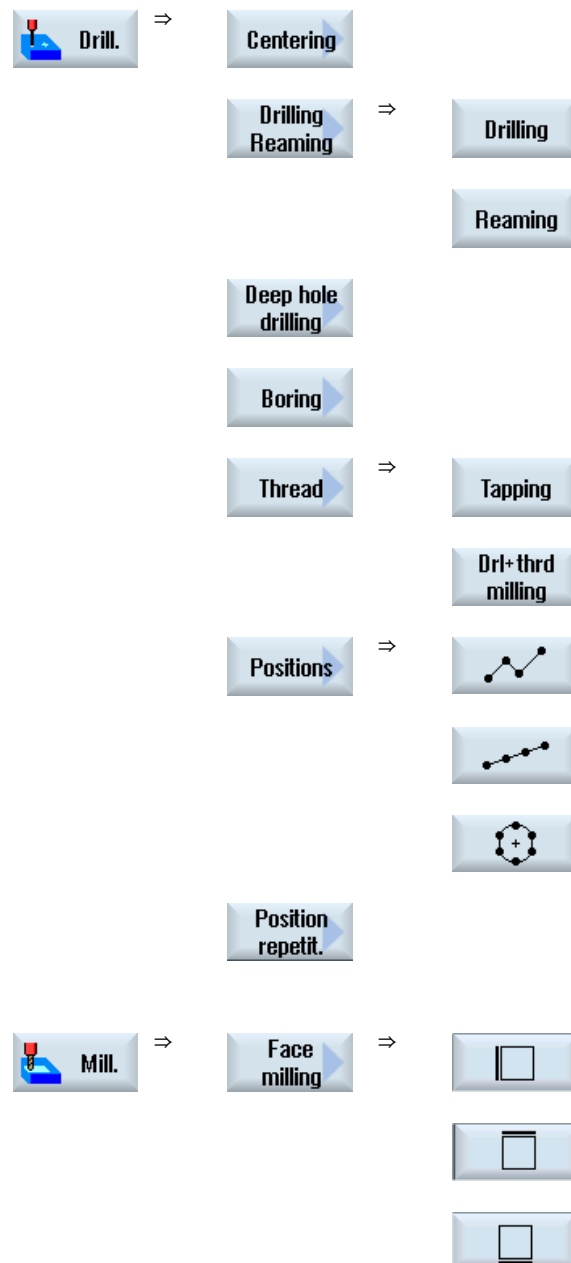

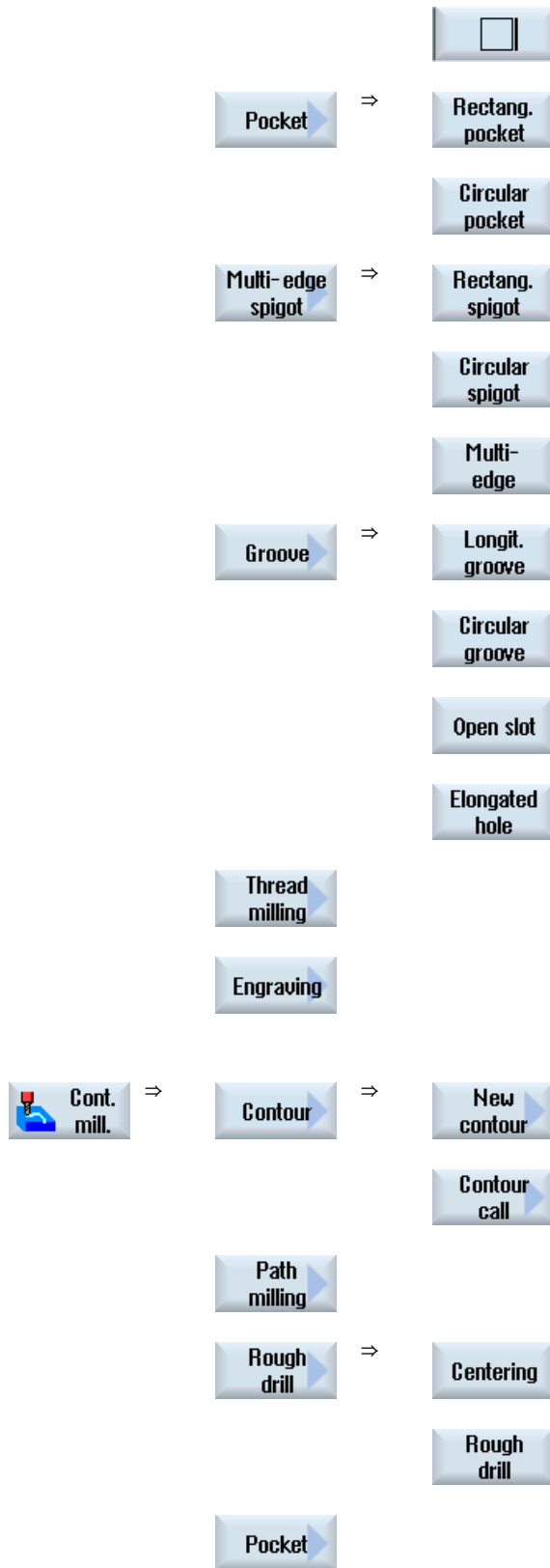

Pocket
res.mat.

Multi-edge
spigot

Spigot
res. mat.

Turning cycles only for milling/turning machine

Turning



Stock
removal



Groove



Undercut



Undercut
form E

Undercut
form F

Undercut
thrd DIN

Undercut
thread

Thread



Thread
long.

Thread
taper

Thread
face

Thread
chain

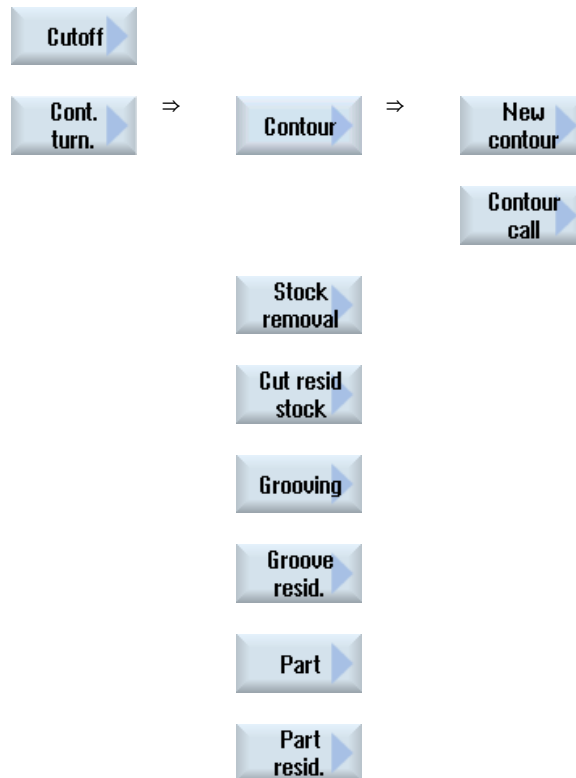

Note:

Please refer to the machine manufacturer's specifications.

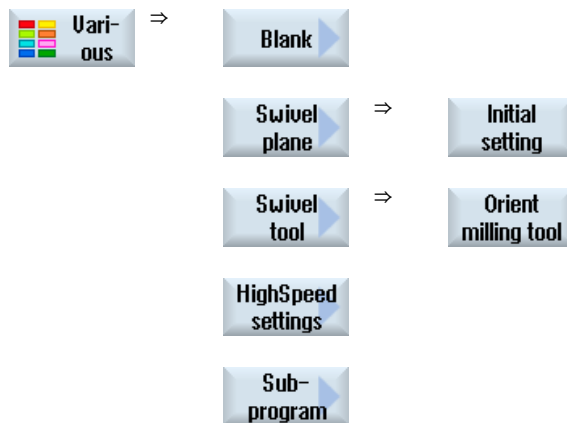



⇒ A menu tree with all of the available measuring versions of the measuring cycle function "Measure workpiece" can be found in the following reference:

Programming Manual Measuring cycles / SINUMERIK 840D sl/828D



⇒ A menu tree with all of the available measuring versions of the measuring cycle function "Measure tool" can be found in the following reference:

Programming Manual Measuring cycles / SINUMERIK 840D sl/828D

6.9 Calling technology functions

6.9.1 Hiding cycle parameters

The documentation describes all the possible input parameters for each cycle. Depending on the settings of the machine manufacturer, certain parameters can be hidden in the screens, i.e. not displayed. These are then generated with the appropriate default values when the cycles are called.

For additional information, please refer to the following documentation:

Commissioning Manual SINUMERIK Operate / SINUMERIK 840D sl

Cycle support

Example



1. Use the softkeys to select whether you want support for programming contours, drilling or milling cycles.



2. Select the desired cycle via the softkey.



3. Enter the parameters and press the "Accept" key.

The cycle is transferred to the editor as G code.

6.9.2 Setting data for cycles

Cycle functions can be influenced and configured using machine and setting data.

For additional information, please refer to the following documentation:

Commissioning Manual SINUMERIK Operate / SINUMERIK 840D sl

6.9.3 Checking cycle parameters

The entered parameters are already checked during the program creation in order to avoid faulty entries.

If a parameter is assigned an illegal value, this is indicated in the input screen and is designated as follows:

- The entry field has a colored background (background color, pink).
- A note is displayed in the comment line.
- If the parameter input field is selected using the cursor, the note is also displayed as tooltip.

The programming can only be completed after the incorrect value has been corrected.

Faulty parameter values are also monitored with alarms during the cycle runtime.

6.9.4 Programming variables

In principle, variables or expressions can also be used in the input fields of the screen forms instead of specific numeric values. In this way, programs can be created very flexibly.

Input of variables

Please note the following points when using variables:

- Values of variables and expressions are not checked since the values are not known at the time of programming.
- Variables and expressions cannot be used in fields in which a text is expected (e.g. tool name).

An exception is the "Engraving" function, in which you can assign the desired text in the text field via a variable as "Variable text".

- Selection fields generally cannot be programmed with variables.

Examples

VAR_A

VAR_A+2*VAR_B

SIN(VAR_C)

6.9.5 Changing a cycle call

You have called the desired cycle via softkey in the program editor, entered the parameters and confirmed with "Accept".

Procedure



1. Select the desired cycle call and press the <Cursor right> key.
The associated input screen of the selected cycle call is opened.

- OR -

Press the <SHIFT + INSERT> key combination.



This starts the edit mode for this cycle call and you can edit it like a normal NC block. This means that it is possible to generate an empty block before the cycle is called. For instance, to insert something before a cycle that is located at the beginning of the program.

Note: In edit mode, the cycle call can be changed in such a way that it can no longer be recompiled in the parameter screen.

You exit the edit mode by pressing the <SHIFT + INSERT> key combination.



- OR -

You are in the edit mode and press the <INPUT> key.

A new line is created after the cursor position.



See also

Generating a G code program (Page 237)

6.9.6 Compatibility for cycle support

The cycle support is generally upwards compatible. This means that cycle calls in NC programs can always be recompiled with a higher software version, changed and then run again.

When transferring NC programs to a machine with a lower software version, it cannot be guaranteed, however, that the program will be able to be changed by recompiling cycle calls.

6.9.7 Additional functions in the input screens

Selection of units

-  If, for example, the unit can be switched in a field, this is highlighted as soon as the cursor is positioned on the element. In this way, the operator recognizes the dependency.
The selection symbol is also displayed in the tooltip.

Display of abs or inc

The abbreviations "abs" and "inc" for absolute and incremental values are displayed behind the entry fields when a switchover is possible for the field.

Help screens

2D and 3D graphics or sectional views are displayed for the parameterization of the cycles.

Online help

If you wish to obtain more detailed information about certain G code commands or cycle parameters, then you can call a context-sensitive online help.

6.10 Measuring cycle support

Measuring cycles are general subroutines designed to solve specific measurement tasks. They can be adapted to specific problems via parameter settings.



Software option

You require the "Measuring cycles" option to use "Measuring cycles".

References

You will find a more detailed description on how to use measuring cycles in:
Programming Manual Measuring cycles / SINUMERIK 840D sl/828D

Creating a ShopMill program

The program editor offers graphic programming to generate machining step programs that you can directly generate at the machine.



Software option

You require the "ShopMill/ShopTurn" option to generate ShopMill machining step programs.

Program loops

When you open a ShopMill program a program test is always executed. For larger program loops or nested program loops, this can result in performance problems in the editor. Therefore, always program program repetitions in the program end block.

Functions

The following functionality is available:

- Technology-oriented program step selection (cycles) using softkeys
- Input windows for parameter assignment with animated help screens
- Context-sensitive online help for every input window
- Support with contour input (geometry processor)

See also

Repeating program blocks (Page 266)

7.1 Program views

You can display a ShopMill program in various views:

- Work plan
- Graphic view
- Parameter screen, either with help screen or graphic view

Work plan

The work plan in the editor provides an overview of the individual machining steps of a program.

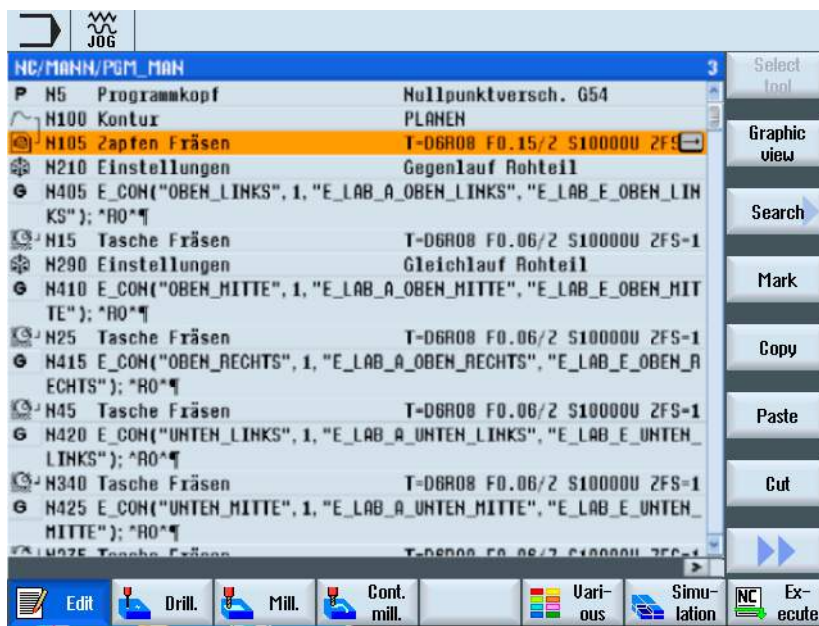

Figure 7-1 Work plan of a ShopMill program



1. You can move between the program blocks in the work plan using the <Cursor up> and <Cursor down> keys.



2. Press the ">>" and "Graphic view" softkeys to display the graphic view.



Note

Switching between the help screen and the graphic view

The key combination <CTRL> + <G> is also available for the switchover between the help screen and the graphic view.

Graphic view

The graphic view shows the contour of the workpiece as a dynamic graphic with broken lines. The program block selected in the work plan is highlighted in color in the graphic view.

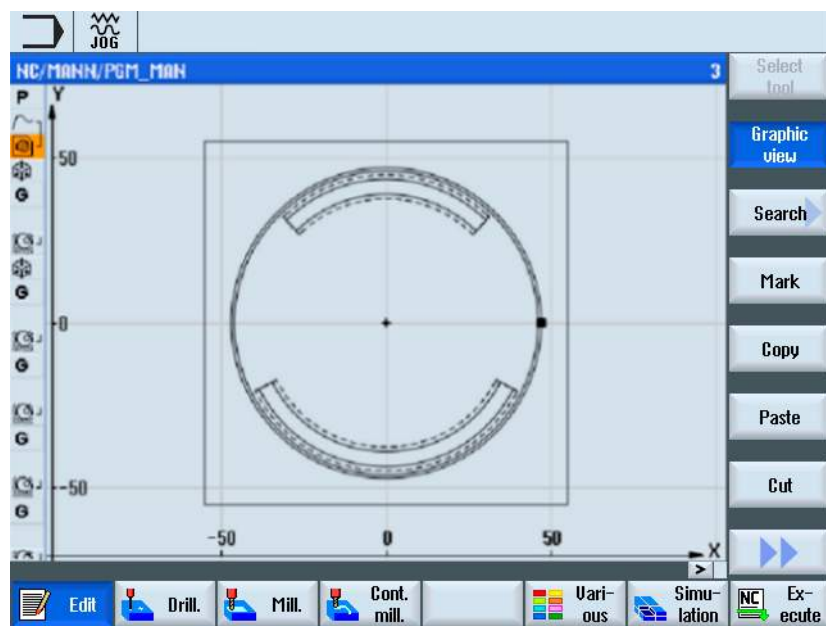

Figure 7-2 Graphic view of a ShopMill program

Parameter screen with help display



Press the <Cursor right> key to open a selected program block or cycle in the work plan.

The associated parameter screen with help screen is then displayed.

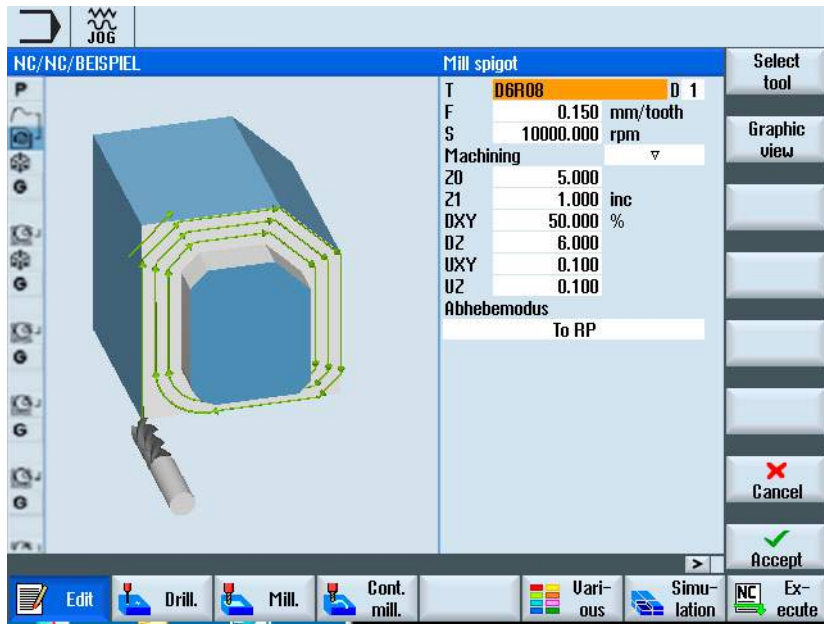

Figure 7-3 Parameter screen with help display

The animated help displays are always displayed with the correct orientation to the selected coordinate system. The parameters are dynamically displayed in the graphic. The selected parameter is displayed highlighted in the graphic.

The color symbols

Red arrow = tool traverses in rapid traverse

Green arrow = tool moves with the machining feedrate

Parameter screen with graphic view



Using the "Graphic view" softkey, you can toggle between the help screen and the graphic view in the screen.

Note

Switching between the help screen and the graphic view

The key combination <CTRL> + <G> is also available for the switchover between the help screen and the graphic view.

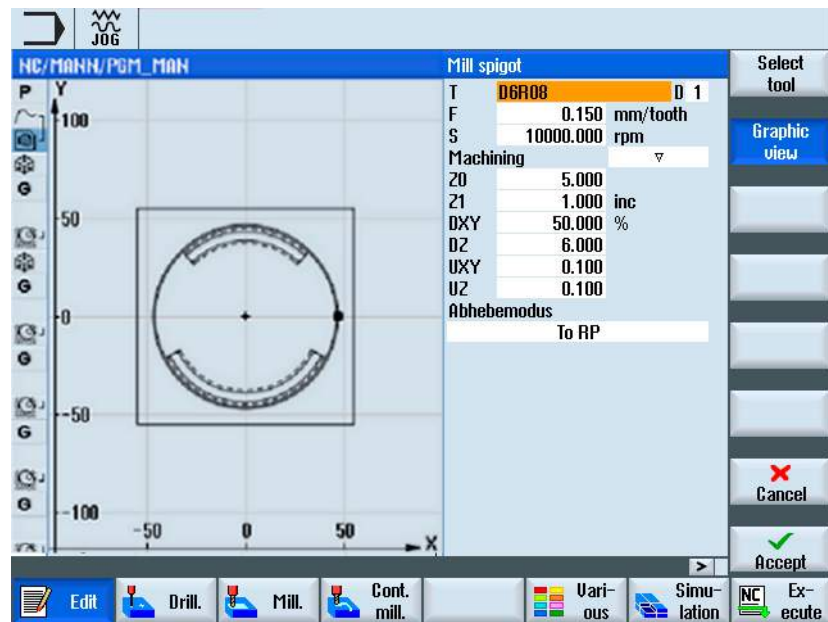

Figure 7-4 Parameter screen with graphic view

7.2 Program structure

A machining step program is divided into three sub-areas:

- Program header
- Program blocks
- End of program

These sub-areas form a work plan.

Program header

The program header contains parameters that affect the entire program, such as blank dimensions or retraction planes.

Program blocks

You determine the individual machining steps in the program blocks. In doing this, you specify the technology data and positions, among other things.

Linked blocks

For the "Contour milling", "Milling", and "Drilling" functions, program the technology blocks and contours or positioning blocks separately. These program blocks are automatically linked by the control and connected by brackets in the work plan.

In the technology blocks, you specify how and in what form the machining should take place, e.g. centering first, and then drilling. In the positioning blocks, you define the positions for drilling or milling operations.

End of program

End of program signals to the machine that the machining of the workpiece has ended. Further, here you set whether program execute should be repeated.

Note

Number of workpieces

You can enter the number of required workpieces using the "Times, counters" window.

7.3 Fundamentals

7.3.1 Machining planes

A plane is defined by means of two coordinate axes. The third coordinate axis (tool axis) is perpendicular to this plane and determines the infeed direction of the tool (e.g. for 2½-D machining).

When programming, it is necessary to specify the working plane so that the control system can calculate the tool offset values correctly. The plane is also relevant to certain types of circular programming and polar coordinates.

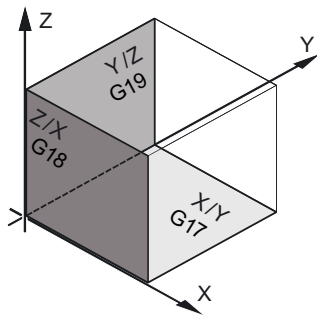

Working planes

Working planes are defined as follows:

Plane		Tool axis
X/Y	G17	Z
Z/X	G18	Y
Y/Z	G19	X

7.3.2 Polar coordinates

The rectangular coordinate system is suitable in cases where dimensions in the production drawing are orthogonal. For workpieces dimensioned with arcs or angles, it is better to define positions using polar coordinates. This is possible if you are programming a straight line or a circle.

Polar coordinates have their zero point at the "pole".

Example

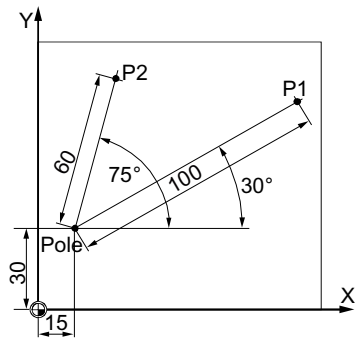

Points P1 and P2 can then be described – with reference to the pole – as follows:

P1: Radius =100 / angle =30°

P2: Radius =60 / angle =75°

7.3.3 Absolute and incremental dimensions

Absolute dimensions

With absolute dimensions, all the position specifications refer to the currently valid zero point. Applied to tool movement this means: The absolute dimension data defines the position, to which the tool is to travel.

Example

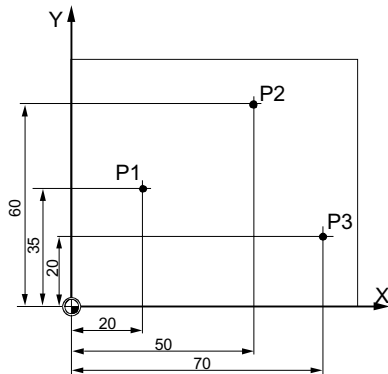

The position data points P1 to P3 in absolute dimensions relative to the zero point are the following:

P1: X20 Y35

P2: X50 Y60

P3: X70 Y20

Incremental dimensions

In the case of production drawings in which dimensions refer to some other point on the workpiece rather than the zero point, it is possible to enter an incremental dimension.

When incremental dimensions are entered, each item of position data refers to a point programmed beforehand.

Example

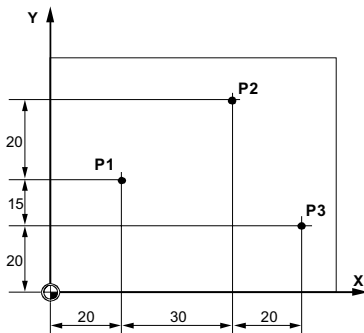

The position data for points P1 to P3 in incremental dimensions are:

P1: X20 Y35 ;(referred to the zero point)

P2: X30 Y20 ;(referred to P1)

P3: X20 Y-35 ;(referred to P2)

7.4 Creating a ShopMill program

Create a separate program for each new workpiece that you would like to produce. The program contains the individual machining steps that must be performed to produce the workpiece.

If you create a new program, a program header and program end are automatically generated.

ShopMill programs can be created in a new workpiece or under the folder "Part programs".

Procedure



1. Select the "Program Manager" operating area.



2. Select the desired storage location and position the cursor on the folder "Part programs" or under the folder "Workpieces" on the workpiece for which you wish to create a program.



3. Press the "New" and "ShopMill" softkeys. The "New machining step programming" window opens.



4. Enter the required name and press the "OK" softkey. The name can contain up to 28 characters (name + dot + 3-character extension). You can use any letters (except accented), digits or the underscore symbol (_). The "ShopMill" program type is selected. The editor is opened and the "Program header" parameter screen is displayed.

Filling out the program header



5. Select a zero offset and enter the dimensions of the blank and the parameters, which are effective over the complete program, e.g. dimension units in mm or inch, tool axis, retraction plane, safety clearance and machining direction.



6. Press the "Accept" softkey. The work plan is displayed. Program header and end of program are created as program blocks. The end of program is automatically defined.









See also





Changing program settings (Page 270)

Creating a new workpiece (Page 582)

7.5 Program header

In the program header, set the following parameters, which are effective for the complete program.

Parameter	Description	Unit
Dimension unit 	The dimension unit (mm or inch) set in the program header only refers to the position data in the actual program. All other data, such as feedrate or tool offsets, is entered in the dimension unit that you have set for the entire machine.	mm inch
Work offset 	The work offset in which the workpiece zero is saved. You can also delete the pre-setting of the parameter if you do not want to specify a work offset.	
Clamping 	Selecting the clamping location of the blank for multiple clamping <ul style="list-style-type: none"> Table All clampings are mounted on a table Note: No turning cycles can be used in the program with the "Table" selection C1 ... All clampings are mounted on a rotary axis Note: Please refer to the machine manufacturer's specifications. 	
Blank 	Define the form and dimensions of the workpiece	
	<ul style="list-style-type: none"> Cylinder 	
∅A	Outer diameter ∅	mm
	<ul style="list-style-type: none"> Polygon 	
N	Number of edges	
SW / L 	Width across flats Edge length	mm
	<ul style="list-style-type: none"> Centered cuboid 	
W	Width of blank	mm
L	Length of blank	mm
	<ul style="list-style-type: none"> Cuboid 	
X0	1. 1st corner point X	mm
Y0	1. 1st corner point Y	mm
X1 	2. 2nd corner point X (abs) or 2nd corner point X referred to X0 (inc)	mm
Y1 	2. 2nd corner point Y (abs) or 2nd corner point Y referred to Y0 (inc)	mm
ZA	Initial dimension	
ZI 	Final dimension (abs) or final dimension in relation to ZA (inc)	
	<ul style="list-style-type: none"> Tube 	
∅A	Outer diameter ∅	mm
∅I 	Inner diameter ∅ (abs) or wall thickness (inc)	mm
	<ul style="list-style-type: none"> Without Without blank use 	

Parameter	Description	Unit
HA - not for "Cuboid" and "Without" blanks	Initial dimension	mm
HI  - not for "Cuboid" and "Without" blanks	Final dimension (abs) or final dimension in relation to HA (inc)	mm
PL 	Machining plane G17 (XY) G18 (ZX) G19 (YZ) Note: The plane settings can already be defined. Ask the machine manufacturer in order that the selection box is available.	
Retraction plane RP Safety clearance SC:	Planes above the workpiece. During machining, the tool travels in rapid traverse from the tool change point to the return plane (RP) and then to the safety clearance (SC). The machining feedrate is activated at this height. When the machining operation is finished, the tool traverses at the machining feedrate away from the workpiece to the safety clearance height. It traverses from the safety clearance to the retraction plane and then to the tool change point in rapid traverse. The retraction plane is entered as an absolute value. The safety clearance must be entered as an incremental value (without sign).	
Machining direction 	When machining a pocket, a longitudinal slot or a spigot, ShopMill takes the machining direction (down-cut or up-cut) and the spindle direction in the tool list into account. The pocket is then machined in a clockwise or counterclockwise direction. During path milling, the programmed contour direction determines the machining direction.	
Retraction position pattern 	<ul style="list-style-type: none"> • Optimized When machining with optimized retraction, the tool travels across the workpiece at the machining feedrate depending on the contour and with a safety clearance (SC). • To RP When retracting to RP, the tool is retracted to the retraction plane when the machining step is complete and infeeds at the new position. Collisions with workpiece obstacles are thus prevented when the tool is retracted and fed in, e.g. when holes in pockets or grooves are machined at different levels and positions. 	

See also

Program header setting, "Clamping" (Page 623)

7.6 Generating program blocks

After a new program is created and the program header is filled out, define the individual machining steps in program blocks that are necessary to machine the workpiece.

You can only create the program blocks between the program header and the program end.

Procedure

Selecting a technological function

1. Position the cursor in the work plan on the line behind which a new program block is to be inserted.
2. Using the softkeys, select the desired function. The associated parameter screen is displayed.



...



3. First, program the tool, offset value, feedrate and spindle speed (T, D, F, S, V) and then enter the values for the other parameters.

Selecting a tool from the tool list



4. Press the "Select tools" softkey if you wish to select the tool for parameter "T".

The "Tool selection" window is opened.



5. Position the cursor on the tool that you wish to use for machining and press the "To program" softkey.

The selected tool is accepted into the parameter screen form.

- OR -



Press the "Tool list" and "New tool" softkeys.



Using the softkeys on the vertical softkey bar, select the required tool with the data and press the "To program" softkey.

The selected tool is accepted into the parameter screen form.

The process plan is displayed and the newly generated program block is marked.

7.7 Tool, offset value, feed and spindle speed (T, D, F, S, V)

Generally, the following parameters are entered for a program block.

Tool (T)

Each time a workpiece is machined, you must program a tool. Tools are selected by name, and the selection is integrated in all parameter screen forms of the machining cycles (with the exception of the straight line/circle).

The tool length offsets become active as soon as the tool is changed.

Tool selection is modal for the straight line/circle, i.e. if the same tool is used to perform several machining steps occur in succession, you only have to program one tool for the first straight line/circle.

Cutting edge (D)

In the case of tools with several cutting edges, there is a separate set of individual tool offset data for each edge. For these tools, you must select or specify the number of the cutting edge that you would like to use for machining.

NOTICE

Risk of collision

Collisions may occur if you specify the wrong cutting edge number for some tools (e.g. a flat chamfering drill with guide spigot or step drill) and then traverse the tool. Always ensure that you enter the correct cutting edge number.

Tool length compensation





Tool length compensation takes effect as soon as the tool is loaded into the spindle. Different tool offsets can be assigned to each tool with multiple cutting edges.

The tool length compensation of the spindle tool remains active even after the program has been executed (RESET).

Radius compensation

The tool radius compensation is automatically included in the machining cycles except for path milling.

For path milling and straight line/circle, you have the option of programming the machining with or without radius compensation. The tool radius compensation is modal for straight lines/circles, i.e. you have to deselect the radius compensation if you want to traverse without radius compensation.

-  Radius compensation to right of contour
-  Radius compensation to left of contour
-  Radius compensation off
-  Radius compensation remains as previously set

Feedrate (F)

The feedrate F (also referred to as the machining feedrate) specifies the speed at which the tool moves when machining the workpiece. The machining feedrate is entered in mm/min, mm/rev or in mm/tooth. The feedrate for milling cycles is automatically converted when switching from mm/min to mm/rev and vice versa.

It is only possible to enter the feedrate in mm/tooth during milling; this ensures that each cutting edge of the milling cutter is cutting under the best possible conditions. The feedrate per tooth corresponds to the linear path traversed by the milling cutter when a tooth is engaged.

With milling cycles, the feedrate for rough cutting is relative to the milling tool center point. This also applies to finish cutting, with the exception of concave curves where the feedrate is relative to the contact point between the tool and workpiece.

The maximum feedrate is determined via machine data.

Converting the feedrate (F) for drilling and milling

The feedrate entered for drilling cycles is automatically converted when switching from mm/min to mm/rev and vice versa using the selected tool diameter.

The feedrate entered for milling cycles is automatically converted when switching from mm/Z to mm/min and vice versa using the selected tool diameter.

Spindle speed (S) / cutting rate (V)

You have the option of either programming the spindle speed (S) or the cutting rate (V). You can toggle between them using the <SELECT> key.

In the milling cycles, the spindle speed is automatically converted to the cutting rate and vice versa.

- Spindle speed and cutting rate remain valid until you program a new tool.
- Spindle speeds are programmed in rpm.
- Cutting rates are programmed in m/min
- You can set the direction of rotation of a tool in the tool list.

Converting the spindle speed (S) / cutting rate (V) when milling.

7.8 Defining machine functions

You can switch-on the coolant or stop machining between the individual machining steps.



Machine manufacturer

Please refer to the machine manufacturer's specifications.

You have the option of defining machine functions as well as your own texts in the "Machine functions" window.

References

A description of the configuration options is provided in Commissioning Manual SINUMERIK Operate / SINUMERIK 840D sl

Procedure

1. The ShopMill program to be edited has been created and you are in the editor.
2. Press the menu forward key and the "Straight Circle" softkey.















3. Press the "Machine functions" softkey. The "Machine functions" window opens.
4. Enter the desired parameters.
5. Press the "Accept" softkey.



See also

Starting and stopping a spindle manually (Page 132)

Parameter	Description	Unit
	Spindle M function, defines the spindle direction of rotation or spindle position  <ul style="list-style-type: none"> • Spindle off •  Spindle rotates clockwise •  Spindle rotates counterclockwise •  Spindle positions 	
Stop position	Spindle stop position - (only for spindle M function SPOS)	Degrees
Other M function	Machine functions, e.g. "Close door" that are additionally provided by the machine manufacturer.	
Coolant 1 	Selects coolant (switches coolant 1 on or off) <ul style="list-style-type: none"> • with • without 	
Coolant 2 	Selects coolant (switches coolant 2 on or off) <ul style="list-style-type: none"> • with • without 	
Tool-spec. function 1 	User machine functions on/off	
Tool-spec. function 2 	User machine functions on/off	
Tool-spec. function 3 	User machine functions on/off	
Tool-spec. function 4 	User machine functions on/off	
DT	Dwell time in seconds Time after which machining is continued.	s
Programmed stop 	Programmed stop on Stops machining at the machine if, under Machine in the "Program control" window, the check box "Programmed stop" was activated.	
Stop 	Stop on Stops machining at the machine.	

7.9 Call work offsets

You can call work offsets (G54, etc.) from any program.

You define work offsets in work offset lists. You can also view the coordinates of the selected offset here.

Procedure



1. Press the "Various", "Transformations" and "Work offset" softkeys. The "Work offset" window opens.
2. Select the desired work offset (e.g. G54).
3. Press the "Accept" softkey. The work offset is transferred into the work plan.

7.10 Repeating program blocks

If certain steps when machining a workpiece have to be executed more than once, it is only necessary to program these steps once. You have the option of repeating program blocks.

Note

Machining several workpieces

The program repeat function is not suitable to program repeat machining of parts.

In order to repeatedly machine the same workpieces (Page 268) program this using end of program.

Start and end marker











You must mark the program blocks that you want to repeat with a start and end marker. You can then call these program blocks up to 200 times within a program. The markers must be unique, i.e. they must have different names. No names used in the NCK can be used.

You can also set markers and repeats after creating the program, but not within linked program blocks.

Note

You can use one and the same marker as end marker for preceding program blocks and as start marker for following program blocks.

Procedure

1. Position the cursor at the program block, behind which a program block that will be repeated should follow.
2. Press the "Various" softkey.

3. Press the ">>" and "Repeat progr." softkeys.

3. Press the "Set marker" and "Accept" softkeys.
A start marker is inserted behind the actual block.

4. Enter the program blocks that you want to repeat later.
5. Press the "Set marker" and "Accept" softkeys again.
An end marker is inserted after the actual block.

6. Continue programming up to the point where you want to repeat the program blocks.
7. Press the "Various" and "Repeat progr." softkeys.

8. Enter the names of the start and end markers and the number of times the blocks are to be repeated.
9. Press the "Accept" softkey.
The marked program blocks are repeated.

7.11 Specifying the number of workpieces

If you wish to produce a certain quantity of the same workpiece, then at the end of the program, specify that you wish to repeat the program.

Control the numbers of times that the program is repeated using the "Times, counters" window. Enter the number of required workpieces using the target number. You can track the number of machined and completed workpieces in the actual counter window.

Controlling program repetition

End of program: Repeat	Times, counter: Counts the workpieces	
No	No	A CYCLE START is required for each workpiece.
No	Yes	A CYCLE START is required for each workpiece. The workpieces are counted.
Yes	Yes	The program is repeated without a new CYCLE START until the required number of workpieces have been machined.
Yes	No	Without a new CYCLE START, the program is repeated an infinite number of times. You can interrupt program execution with <RESET>.

Procedure

1. Open the "Program end" program block, if you want to machine more than one workpiece.
2. In the "Repeat" field, enter "Yes".
3. Press the "Accept" softkey.



If you start the program later, program execution is repeated.

Depending on the settings in the "Times, counters" window, the program is repeated until the set number of workpieces has been machined.

See also

Displaying the program runtime and counting workpieces (Page 205)

7.12 Changing program blocks

You can subsequently optimize the parameters in the programmed blocks or adapt them to new situations, e.g. if you want to increase the feedrate or shift a position. In this case, you can directly change all the parameters in every program block in the associated parameter screen form.

Procedure



1. Select the program that you wish to change in the "Program Manager" operating area.



2. Press the <Cursor right> or <INPUT> key.
The work plan of the program is displayed.



3. Position the cursor in the work plan at the desired program block and press the <Cursor right> key.



The parameter screen for the selected program block is displayed.

4. Make the desired changes.



5. Press the "Accept" softkey.

- OR -



Press the <Cursor left> key.

The changes are accepted in the program.

7.13 Changing program settings

Function

All parameters defined in the program header, with the exception of the dimension unit, can be changed at any location in the program.

The settings in the program header are modal, i.e. they remain active until they are changed.

For the simulation and the simultaneous recording use a blank. A useful simulation can only be achieved with a blank that is as close as possible to the real blank.

For the blank of the workpiece, define the shape (cuboid, tube, cylinder, polygon or centered cuboid) and your dimensions.

The blank entry always refers to the work offset currently effective at the position in the program.

Define a new blank, e.g. in the machining step program, if you want to change the visible section during simulation.

This is useful for the work offset, coordinate transformation, cylinder peripheral surface transformation and swiveling functions. First program the functions listed above and then define a new blank.

Procedure



1. Select the "Program" operating area.











2. Press the "Various" and "Settings" softkeys. The "Settings" input window opens.



7.13.1 Parameters

Table 7- 1

Parameter	Description	Unit
Clamping 	<p>Selecting the clamping location of the blank for multiple clamping</p> <ul style="list-style-type: none"> • Table All clampings are mounted on a table <p>Note: No turning cycles can be used in the program with the "Table" selection.</p> <ul style="list-style-type: none"> • C1 ... All clampings are mounted on a rotary axis <p>Note: Please refer to the machine manufacturer's specifications.</p>	
Blank 	<p>Selecting the blank:</p> <ul style="list-style-type: none"> • Cylinder • Tube • Centered cuboid • Cuboid • Polygon • Without 	
	<ul style="list-style-type: none"> • Cylinder 	
∅A	Outer diameter ∅	mm
	<ul style="list-style-type: none"> • Tube 	
∅A	Outer diameter ∅	mm
∅I 	Inner diameter ∅ (abs) or wall thickness (inc)	mm
	<ul style="list-style-type: none"> • Centered cuboid 	
W	Width of blank	mm
L	Length of blank	mm
	<ul style="list-style-type: none"> • Cuboid 	
X0	1st corner point X	mm
Y0	1st corner point Y	mm
X1	2nd corner point X (abs) or 2nd corner point X referred to X0 (inc)	mm
Y1	2nd corner point X (abs) or 2nd corner point X referred to X0 (inc)	mm
ZA	Initial dimension	mm
ZI 	Final dimension (abs) or final dimension in relation to ZA (inc)	mm
	<ul style="list-style-type: none"> • Polygon 	
N	Number of edges	
SW	Width across flats	mm
L	Edge length	
		

Parameter	Description	Unit
	<ul style="list-style-type: none"> Without <p>No blank use</p>	
HA	Initial dimension	mm
HI 	Final dimension (abs) or final dimension in relation to HA (inc)	mm
PL 	Machining plane <ul style="list-style-type: none"> G17 (XY) G18 (ZX) G19 (YZ) 	
RP	Retraction plane (abs)	mm
SC	Safety clearance (inc) Acts in relation to the reference point. The direction in which the safety clearance is effective is automatically determined by the cycle.	mm
Machining direction 	Milling direction <ul style="list-style-type: none"> Down-cut Up-cut 	
Retraction position pattern 	Lift mode before new infeed <ul style="list-style-type: none"> To RP Optimized 	mm

7.14 Selection of the cycles via softkey

Overview of machining steps

The following machining steps are available for insertion.

All of the cycles/functions available in the control are shown in this display. However, at a specific system, only the steps possible corresponding to the selected technology can be selected.

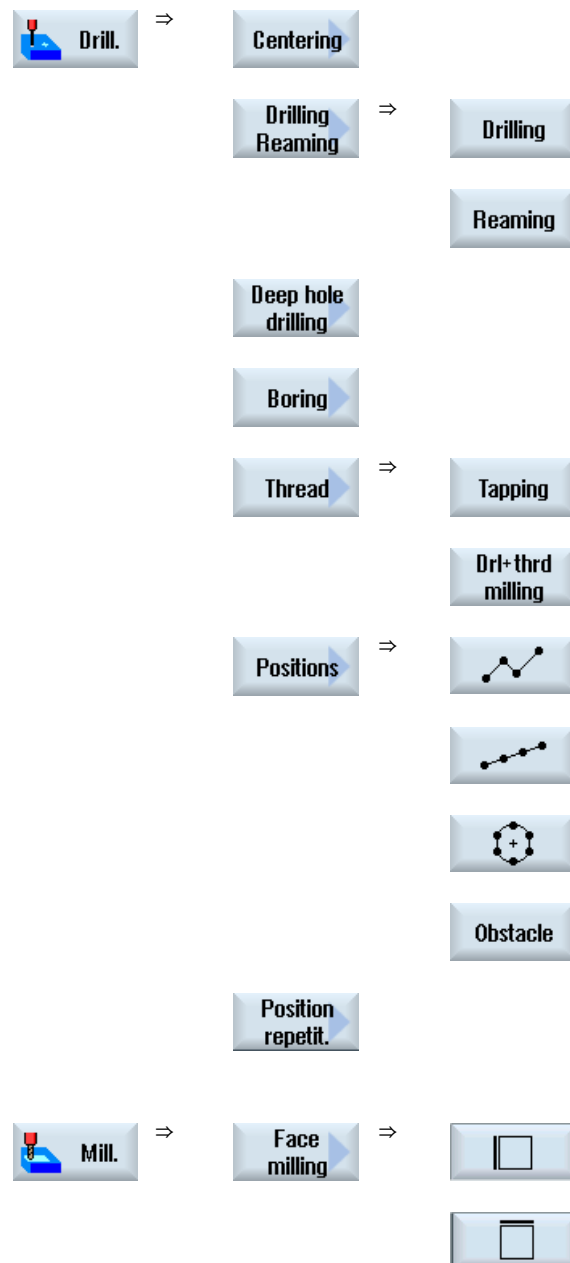

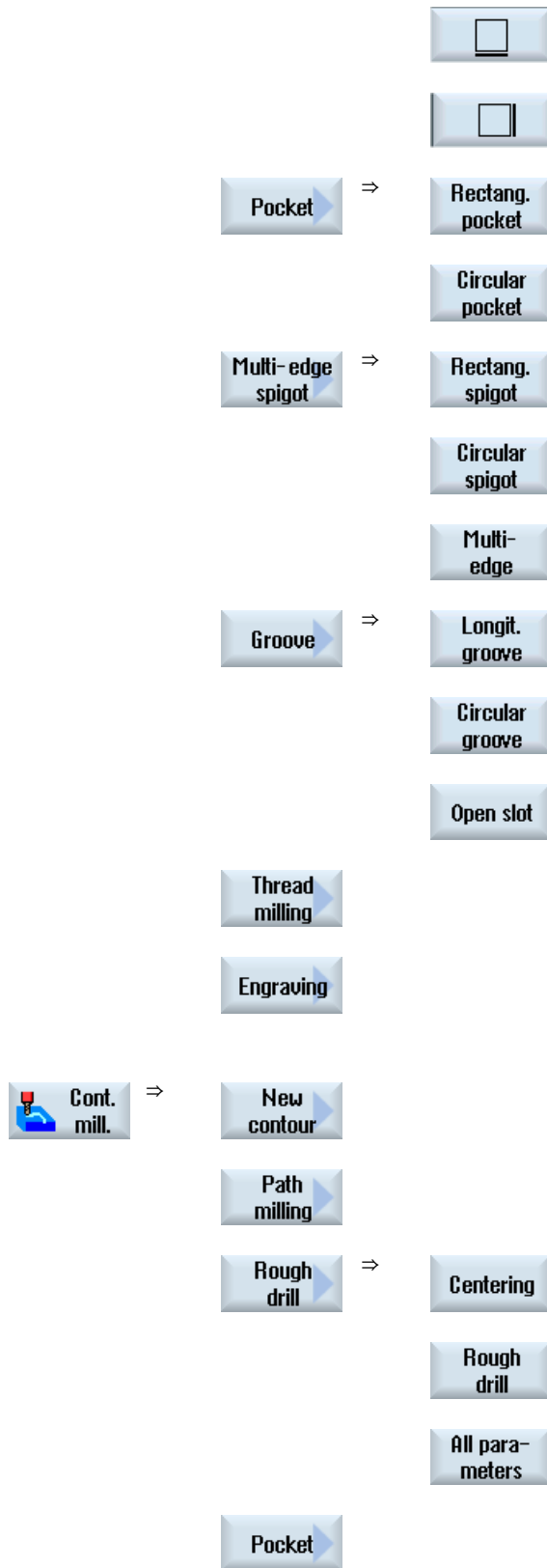

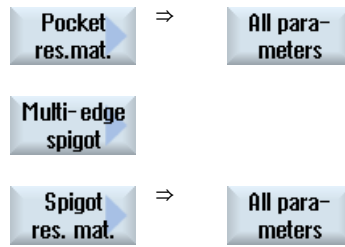

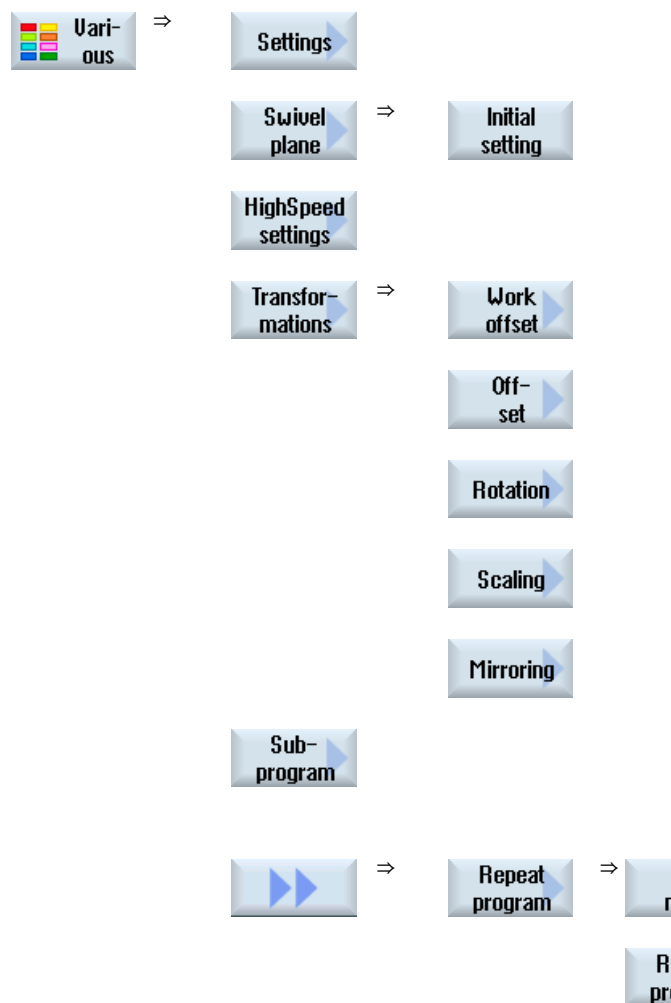

Note:

Please refer to the machine manufacturer's specifications.

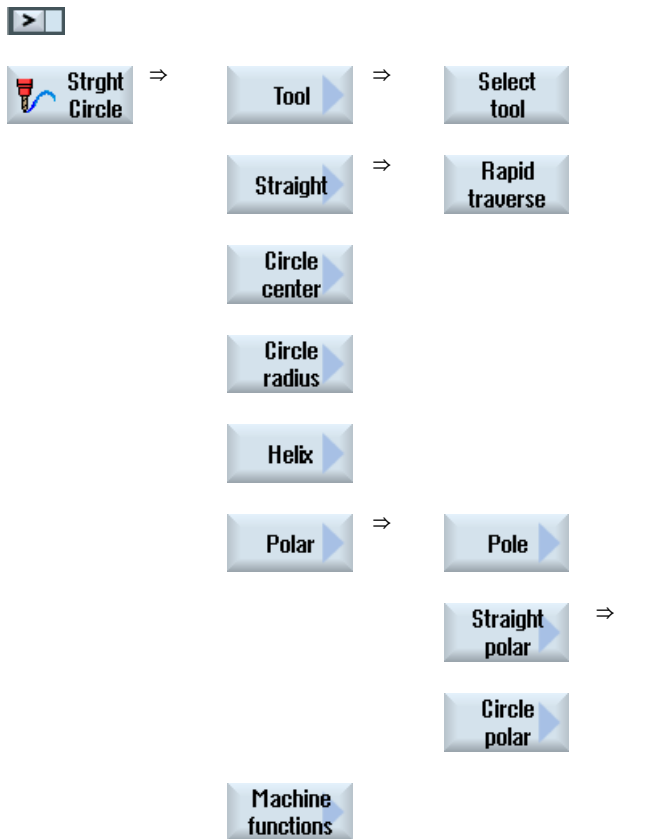



 => A menu tree with all of the available measuring versions of the measuring cycle function "Measure workpiece" can be found in the following reference:

Programming Manual Measuring cycles / SINUMERIK 840D sl/828D

 => A menu tree with all of the available measuring versions of the measuring cycle function "Measure tool" can be found in the following reference:

Programming Manual Measuring cycles / SINUMERIK 840D sl/828D

7.15 Calling technology functions

7.15.1 Additional functions in the input screens

Selection of units

-  If, for example, the unit can be switched in a field, this is highlighted as soon as the cursor is positioned on the element. In this way, the operator recognizes the dependency.

The selection symbol is also displayed in the tooltip.

Display of abs or inc

The abbreviations "abs" and "inc" for absolute and incremental values are displayed behind the entry fields when a switchover is possible for the field.

Help screens

2D and 3D graphics or sectional views are displayed for the parameterization of the cycles.

Online help

If you wish to obtain more detailed information about certain G code commands or cycle parameters, then you can call a context-sensitive online help.

7.15.2 Programming variables

In principle, variables or expressions can also be used in the input fields of the screen forms instead of specific numeric values. In this way, programs can be created very flexibly.

Input of variables

Please note the following points when using variables:

- Values of variables and expressions are not checked since the values are not known at the time of programming.
- Variables and expressions cannot be used in fields in which a text is expected (e.g. tool name).

An exception is the "Engraving" function, in which you can assign the desired text in the text field via a variable as "Variable text".

- Selection fields generally cannot be programmed with variables.

Examples

VAR_A

VAR_A+2*VAR_B

SIN(VAR_C)

7.15.3 Checking input parameters

When generating the program, the parameters that are entered are already checked in order to avoid making incorrect entries.

If a parameter is assigned an illegal value, this is indicated in the input screen and is designated as follows:

- The entry field has a colored background (background color, pink).
- A note is displayed in the comment line.
- If the parameter input field is selected using the cursor, the note is also displayed as tooltip.

The programming can only be completed after the incorrect value has been corrected.

Incorrect parameter values are also monitored with alarms during the cycle runtime.

7.15.4 Setting data for technological functions

Technological functions can be influenced and corrected using machine or setting data.

For additional information, please refer to the following documentation:

Commissioning Manual SINUMERIK Operate / SINUMERIK 840D sl

7.15.5 Changing a cycle call

You have called the desired cycle via softkey in the program editor, entered the parameters and confirmed with "Accept".

Procedure



1. Select the desired cycle call and press the <Cursor right> key.
The associated input screen of the selected cycle call is opened.

- OR -



Press the <SHIFT + INSERT> key combination.

This starts the edit mode for this cycle call and you can edit it like a normal NC block. This means that it is possible to generate an empty block before the cycle is called. For instance, to insert something before a cycle that is located at the beginning of the program.

Note: In edit mode, the cycle call can be changed in such a way that it can no longer be recompiled in the parameter screen.

You exit the edit mode by pressing the <SHIFT + INSERT> key combination.



- OR -



You are in the edit mode and press the <INPUT> key.

A new line is created after the cursor position.

7.15.6 Compatibility for cycle support

The cycle support is generally upwards compatible. This means that cycle calls in NC programs can always be recompiled with a higher software version, changed and then run again.

When transferring NC programs to a machine with a lower software version, it cannot be guaranteed, however, that the program will be able to be changed by recompiling cycle calls.

7.16 Measuring cycle support

Measuring cycles are general subroutines designed to solve specific measurement tasks. They can be adapted to specific problems via parameter settings.



Software option

You require the "Measuring cycles" option to use "Measuring cycles".

References

You will find a more detailed description on how to use measuring cycles in:
Programming Manual Measuring cycles / SINUMERIK 840D sl/828D

7.17 Example, standard machining

General

The following example is described in detail as ShopMill program. A G code program is generated in the same way; however, some differences must be observed.

If you copy the G code program listed below, read it into the control and open it in the editor, then you can track the individual program steps.



Machine manufacturer

Under all circumstances, observe the machine manufacturer's instructions.

Tools

The following tools are saved in the tool manager:

Tool name	Tool diameter	Cutting materials	Number of teeth
Face miller	D80 mm	HM	Z = 8
End mill	D20 mm	HM	Z = 3
End mill	D10 mm	HM	Z = 3
End mill	D8 mm	HM	Z = 3
Centering tool (NC spotdrill)	D10 mm	HM	-
Twist drill	D10 mm	HSS	-

The correction (compensation) values for length and radius as well as the tip angle for drills and number of teeth for milling tools should be entered into the tool list. If you are working with ShopMill, in addition, enter the spindle direction of rotation and coolant.

Adapt the cutting data to the tools used and the specific application conditions.

Blank

Dimensions: 185 x 185 x 50

Material: Aluminum

ZI -50abs
PL G17 (XY) Plane selection, if MD 52005 = 0
RP 100
SC 1
Machining direction Climbing
Retraction position pattern Optimized



- Press the "Accept" softkey.
The work plan is displayed. Program header and end of program are created as program blocks.
The end of program is automatically defined.

2. Rectangular spigots, face milling



- Press the "Milling" and "Face milling" softkeys.
- Enter the following technology parameters:
T Facing tool_80mm **D1** **F** 0.10 mm/tooth **V** 750 m/min
- Enter the following parameters:

Machining Roughing (∇)

Direction 

X0 -2.5abs
Y0 -2.5abs
Z0 1abs
X1 185abs
Y1 185abs
Z1 0abs
DXY 80%
DZ 2.0
UZ 0



- Press the "Accept" softkey.

3. Outside contour of the workpiece



1. Press the "Milling", "Multi-edge spigot" and "Rectangular spigot" softkeys.

2. Enter the following technology parameters:
T End mill_20mm **D1** **F** 0.140 mm/tooth **V** 240 m/min

3. Enter the following parameters:

Position of reference point 

Machining	Roughing (▽)
Type of position	Single position
X0	0abs
Y0	0abs
Z0	0abs
W1	185(fictitious blank dimension)
L1	185(fictitious blank dimension)
W	180abs
L	180abs
R	10abs
α0	0degrees
Z1	20inc
DZ	5
UXY	0
UZ	0



4. Press the "Accept" softkey.

Outside contour of the island



1. Press the "Contour milling", "Contour" and "New contour" softkeys. The "New Contour" input window opens.



2. Enter the contour name (in this case: Part_4_ISLAND). The contour calculated as NC code is written as an internal subprogram between a start and an end marker containing the entered name.



3. Press the "Accept" softkey. The "Starting Point" input window opens.

4. Enter the starting point of the contour.
X 90abs Y 25abs



5. Press the "Accept" softkey.



6. Enter the following contour elements and acknowledge using the "Accept" softkey.



- 6.1. X 25abs FS 15



- 6.2. Y 115abs R 20



- 6.3. X 15abs Y 135abs



- 6.4. Y 155abs R 10



- 6.5. X 60abs R 15













- 6.6. Y 135abs R 20





7. Direction of rotation Ⓞ



8. R 25 X 110abs

	9.1	Y	155abs	R	15	
						
	9.2	R	0			
	9.3	X	165abs	Y	95abs	α 1290 degreesR 0
	9.4	X	155abs	α 1	240	DegreR 28 es
	9.5	FS	0			
	9.6	X	140abs	Y	25 abs	α 1225 degreesR 0
	10.	Press the ">>" and "Close contour" softkeys, to close the contour.				
						
	11.	Press the "Accept" softkey.				
						

Contour milling/solid machining

- 

1. Press the "Contour milling" and "Pocket" softkeys.
2. Enter the following technology parameters:
T End_mill_20mm **D1** F 0.1 mm/tooth V 240 m/min
3. Enter the following parameters:
Machining ▾
Z0 0abs
Z1 10inc
DXY 40%
DZ 3.5
UXY 0mm
UZ 0
Starting point Auto
Insertion Helical

EP 1.0
 ER 2.0
Lift mode Select, e.g. to the retraction plane



4. Press the "Accept" softkey.

Note

- When selecting the milling tool, please make sure that the tool diameter is large enough to cut the intended pocket. A message will be displayed if you make a mistake.
- If you want to finish cut the pocket, you must assign parameters UXY and UZ accordingly and add a second solid machining cycle for finishing.

5. Milling a rectangular pocket (large)



1. Press the "Milling", "Pocket" and "Rectangular pocket" softkeys. The "Rectangular Pocket" input window opens.

2. Enter the following technology parameters:
 T End mill_10mm D1 F 0.04 mm/tooth V 260 m/min
3. Enter the following parameters:

Reference point 

Machining	Roughing (∇)
Machining position	Single position
X0	90abs
Y0	60abs
Z0	0abs
W	40
L	70
R	10
α0	15degrees
Z1	4inc
DXY	40%
DZ	4
UXY	0

UZ	0
Insertion	Helical
EP	1
ER	2
Solid machining	Complete machining



4. Press the "Accept" softkey.

6. Milling a rectangular pocket (small)



1. Press the "Milling", "Pocket" and "Rectangular pocket" softkeys. The "Rectangular Pocket" input window opens.

2. Enter the following technology parameters:
T End mill_10mm **D1** **F** 0.04 mm/tooth **V** 260 m/min
3. Enter the following parameters:

Reference point



Machining	Roughing (▽)
Machining position	Single position
X0	90abs
Y0	60abs
Z0	-4abs
W	20
L	35
R	5
α0	15degrees
Z1	2inc
DXY	40%
DZ	2
UXY	0
UZ	0
Insertion	Oscillation
EW	Maximum insertion angle



- Solid machining** Complete machining
4. Press the "Accept" softkey.

7. Milling a circumferential slot



1. Press the "Milling", "Groove" and "Circ. groove" softkeys.
The "Circumferential Groove" input window opens.

2. Enter the following technology parameters:
T End_mill_8mm D1 F 0.018 mm/tooth FZ 0.010 mm/tooth
V 230 m/min

3. Enter the following parameters:

Machining	Roughing (▽)
Circular pattern	Pitch circle
X0	85abs
Y0	135abs
Z0	0abs
N	1
R	40
α0	180degrees
α1	180degrees
W	10
Z1	3inc
DZ	3
UXY	0mm



4. Press the "Accept" softkey.

8. Drilling/centering



1. Press the "Drilling" and "Centering" softkeys.
The "Centering" input window opens.

2. Enter the following technology parameters:

T Centering_tool_10m **D1** **F** 1000 mm/min **S** 12000 rev/min

3. Enter the following parameters:

Diameter/tip	Diameter
∅	5
DT	0.6 s



4. Press the "Accept" softkey.

9. Drilling/reaming



1. Press the "Drilling", "Drilling reaming" and "Drilling" softkeys.
The "Drilling" input window opens.

2. Enter the following technology parameters:

T DRILL10 **D1** **F** 500 mm/min **S** 1600 rev/min

3. Enter the following parameters:

Diameter/tip	Tip
Z1	-25abs
Predrilling	No
Through drilling	No
DT	0



4. Press the "Accept" softkey.

10. Positions



1. Press the "Drilling", "Positions" and "Drilling Positions" softkeys. The "Any Positions" input window opens.

2. Enter the following parameters:

	Rectangular
Z0	-10abs
X0	15abs
Y0	15abs
X1	165abs
Y1	15abs



3. Press the "Accept" softkey.

11. Obstacle



1. Press the "Drilling", "Positions", and "Obstacle" softkeys. The "obstacle" input window opens.

2. Enter the following parameters:

Z	2abs
----------	------



3. Press the "Accept" softkey.

Note

If this obstacle cycle is not inserted, the drill will violate the right-hand corner of the island contour. Alternately, you could increase the safety clearance.

12. Positions



1. Press the "Drilling", "Positions" and "Drilling Positions" softkeys. The "Any Positions" input window opens.

2. Enter the following parameters:

	Rectangular
Z0	-10abs
X2	165abs
Y2	165abs
X3	15abs
Y3	165abs



3. Press the "Accept" softkey.

13. Milling the circular pocket



1. Press the "Milling", "Pocket" and "Circular pocket" softkeys. The "Circular Pocket" input window opens.

2. Enter the following technology parameters:

T End_mill_8mm	D1	F 0.018 mm/tooth	V 230 m/min
-----------------------	-----------	-------------------------	--------------------

3. Enter the following parameters:

Machining	Roughing (▽)
Machining type	Plane-by-plane
Machining position	Single position
X0	85abs
Y0	135abs
Z0	-10abs
Diameter	30
Z1	12inc
DXY	40%
DZ	5

UXY 0mm
UZ 0
Insertion Helical
EP 1.0
ER 2.0
Solid machining Complete machining



4. Press the "Accept" softkey.

You also program the four countersinks $\varnothing 16$ and 4 deep using a circular pocket and repeating positions 2, 3 and 4.

7.17.3 Results/simulation test

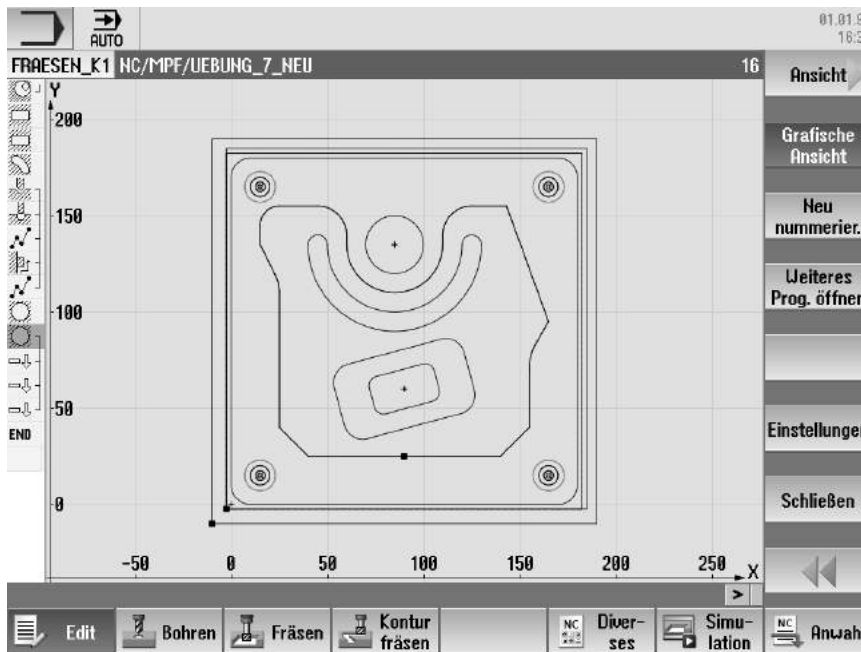

Figure 7-5 Programming graphics



Figure 7-6 Machining schedule

Program test by means of simulation

During simulation, the current program is calculated in its entirety and the result displayed in graphic form.

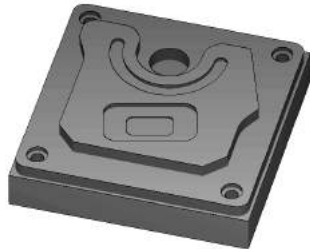

Figure 7-7 3D view

7.17.4 G code machining program

```
G17 G54 G71
WORKPIECE(,,"","BOX",112,1,-20,-100,-2.5,-2.5,182.5,182.5)
;*****Tool change*****
T="FACING TOOL" D1 M6
G95 FZ=0.1 S3000 M3 M8
CYCLE61(50,1,1,0,-2.5,-2.5,185,185,2,80,0,0.1,31,0,1,10)
G0 Z200 M9
;*****Tool change*****
T="MILLER20" D1 M6
G95 FZ=0.14 S3900 M3 M8
CYCLE76(50,0,1,,20,180,180,10,0,0,0,5,0,0,0.14,0.14,0,1,185,185,1,2,2100,1,101)
;CYCLE62(,2,"MA1","MA0")
CYCLE62(,2,"E_LAB_A_PART_4_POCKET","E_LAB_E_PART_4_POCKET")
CYCLE62(,2,"E_LAB_A_PART_4_ISLAND","E_LAB_E_PART_4_ISLAND")
CYCLE63("PART_4_GEN_01",11,50,0,1,10,0.1,0.3,40,3.5,0,0,0,0,0,2,1,15,1,2,,,,,0,101,111)
G0 Z200 M9
;*****Tool change*****
T="MILLER10" D1 M6
G95 FZ=0.04 S8500 M3 M8
POCKET3(50,0,1,4,70,40,10,90,60,15,4,0,0,0.04,0.2,0,21,40,8,3,15,2,1,0,1,2,11100,11,111)
POCKET3(50,-4,1,2,35,20,6,90,60,15,2,0,0,0.04,0.2,0,31,40,8,3,15,10,2,0,1,2,11100,11,111)
G0 Z200 M9
;*****Tool change*****
T="MILLER8" D1 M6
G95 FZ=0.018 S9000 M3 M8
SLOT2(50,0,1,,3,1,180,10,85,135,40,180,90,0.01,0.018,3,0,0,2001,0,0,0,,0,1,2,100,1001,101)
G0 Z200 M9
;*****Tool change*****
T="CENTERING TOOL10" D1 M6
G94 F1000 S12000 M3 M8
MCALL CYCLE81(50,-10,1,5,,0,10,1,11)
POS_1: CYCLE802(111111111,111111111,15,15,165,15,165,165,15,165,,,,,,,,,,,,,0,0,1)
MCALL
G0 Z200 M9
;*****Tool change*****
T="DRILL10" D1 M6
G94 F500 S1600 M3 M8
MCALL CYCLE82(50,-10,1,-25,,0,0,1,12)
REPEATB POS_1 ;#SM
MCALL
G0 Z200 M9
;*****Tool change*****
```



```

T="MILLER8" D1 M06
G95 FZ=0.018 S12000 M3 M8
POCKET4(50,-10,1,12,30,85,135,5,0,0,0.018,0.01,0,21,40,9,15,2,1,0,1,2,10100,111,111)
MCALL POCKET4(50,-10,1,4,16,0,0,5,0,0,0.018,0.018,0,11,40,9,15,0,2,0,1,2,10100,111,111)
REPEATB POS_1 ;#SM
MCALL
G0 Z200 M9
;*****Tool change*****
;Contour chamfering
T="CENTERING TOOL10" D1 M6
G94 F500 S8000 M3 M8
CYCLE62(,2,"E_LAB_A_PART_4_ISLAND","E_LAB_E_PART_4_ISLAND")
CYCLE72(" ",100,0,1,20,2,0.5,0.5,500,100,305,41,1,0,0.1,1,0,0,0.3,2,101,1011,101)
POCKET3(50,0,1,4,70,40,10,90,60,15,4,0,0,500,0.2,0,25,40,8,3,15,2,1,0,0.3,2,11100,11,111)
POCKET3(50,-4,1,2,35,20,6,90,60,15,2,0,0,500,0.2,0,35,40,8,3,15,10,2,0,0.3,2,11100,11,111)
SLOT2(50,0,1,,3,1,180,10,85,135,40,180,90,0.01,500,3,0,0,2005,0,0,0,,0,0.3,2,100,1001,101)
POCKET4(50,-10,1,12,30,85,135,5,0,0,500,0.01,0,15,40,9,15,0,2,0,0.3,2,10100,111,111)
MCALL POCKET4(50,-10,1,4,16,0,0,5,0,0,500,0.025,0,15,40,9,15,0,2,0,0.3,4,10100,111,111)
REPEATB POS_1 ;#SM
MCALL
G0 Z200 M9
M30
;*****Contour*****
E_LAB_A_PART_4_POCKET: ;#SM Z:5
;#7__DlgK contour definition begin - Don't change!;*GP*;*RO*;*HD*
G17 G90 DIAMOF;*GP*
G0 X-10 Y-10 ;*GP*
G1 X190 ;*GP*
Y190 ;*GP*
X-10 ;*GP*
Y-10 ;*GP*
;CON,0,0.0000,4,4,MST:0,0,AX:X,Y,I,J;*GP*;*RO*;*HD*
;S,EX:-10,EY:-10;*GP*;*RO*;*HD*
;LR,EX:190;*GP*;*RO*;*HD*
;LU,EY:190;*GP*;*RO*;*HD*
;LL,EX:-10;*GP*;*RO*;*HD*
;LA,EX:-10,EY:-10;*GP*;*RO*;*HD*
;#End contour definition end - Don't change!;*GP*;*RO*;*HD*
E_LAB_E_PART_4_POCKET:
;
E_LAB_A_PART_4_ISLAND: ;#SM Z:2
;#7__DlgK contour definition begin - Don't change!;*GP*;*RO*;*HD*
G17 G90 DIAMOF;*GP*
G0 X90 Y25 ;*GP*
G1 X25 CHR=15 ;*GP*

```

7.17 Example, standard machining

```
Y115 RND=20 ;*GP*
X15 Y135 ;*GP*
Y155 RND=10 ;*GP*
X60 RND=15 ;*GP*
Y135 ;*GP*
G3 X110 I=AC(85) J=AC(135) ;*GP*
G1 Y155 RND=15 ;*GP*
X143.162 ;*GP*
X165 Y95 ;*GP*
X155 Y77.679 RND=28 ;*GP*
Y40 ;*GP*
X140 Y25 ;*GP*
X90 ;*GP*
;CON,0,0.0000,14,14,MST:0,0,AX:X,Y,I,J;*GP*;*RO*;*HD*
;S,EX:90,EY:25;*GP*;*RO*;*HD*
;LL,EX:25;*GP*;*RO*;*HD*
;F,LFASE:15;*GP*;*RO*;*HD*
;LU,EY:115;*GP*;*RO*;*HD*
;R,RROUND:20;*GP*;*RO*;*HD*
;LA,EX:15,EY:135;*GP*;*RO*;*HD*
;LU,EY:155;*GP*;*RO*;*HD*
;R,RROUND:10;*GP*;*RO*;*HD*
;LR,EX:60;*GP*;*RO*;*HD*
;R,RROUND:15;*GP*;*RO*;*HD*
;LD,EY:135;*GP*;*RO*;*HD*
;ACCW,EX:110,RAD:25;*GP*;*RO*;*HD*
;LU,EY:155,AT:0;*GP*;*RO*;*HD*
;R,RROUND:15;*GP*;*RO*;*HD*
;LR;*GP*;*RO*;*HD*
;LA,EX:165,EY:95,ASE:290;*GP*;*RO*;*HD*
;LA,EX:155,ASE:240;*GP*;*RO*;*HD*
;R,RROUND:28;*GP*;*RO*;*HD*
;LD;*GP*;*RO*;*HD*
;LA,EX:140,EY:25,ASE:225;*GP*;*RO*;*HD*
;LA,EX:90,EY:25;*GP*;*RO*;*HD*
;#End contour definition end - Don't change!;*GP*;*RO*;*HD*
E_LAB_E_PART_4_ISLAND:
```

Programming technological functions (cycles)

8.1 Drilling

8.1.1 General

General geometry parameters

- Retraction plane RP and reference point Z0

Normally, reference point Z0 and retraction plane RP have different values. The cycle assumes that the retraction plane is in front of the reference point.

Note

If the values for reference point and retraction planes are identical, a relative depth specification is not permitted. Error message "Reference plane defined incorrectly" is output and the cycle is not executed.

This error message is also output if the retraction plane is located after the reference point, i.e. its distance to the final drilling depth is smaller.

- Safety clearance SC

Acts in relation to the reference point. The direction in which the safety clearance is active is automatically determined by the cycle.

- Drilling depth

Depending on the selection of the drill shank or drill tip or the centering diameter, the programmed drilling depth refers to the following for cycles with a selection field:

- Tip (drilling depth in relation to the tip)

The drill is inserted into the workpiece until the drill tip reaches the value programmed for Z1.

- Shank (drilling depth in relation to the shank)

The drill is inserted into the workpiece until the drill shank reaches the value programmed for Z1. The angle entered in the tool list is taken into account.

- Diameter (centering in relation to the diameter, only for CYCLE81)

The diameter of the centering hole is programmed at Z1. In this case, the tip angle of the tool must be specified in the tool list. The drill is inserted into the workpiece until the specified diameter is reached.

8.1 Drilling

Drilling positions

The cycle assumes the tested hole coordinates of the plane.

The hole centers should therefore be programmed before or after the cycle call as follows (see also Section, Cycles on single position or position pattern (MCALL)):

- A single position should be programmed before the cycle call
- Position patterns (MCALL) should be programmed after the cycle call
 - as drilling pattern cycle (line, circle, etc.) or
 - as a sequence of positioning blocks for the hole centers

8.1.2 Centering (CYCLE81)

8.1.2.1 Function

Function

With the "Centering" function, the tool drills with the programmed spindle speed and feedrate either:

- Down to the programmed final drilling depth or
- So deep until the programmed diameter of the centering is reached

The tool is retracted after a programmed dwell time has elapsed.

Approach/retraction

1. The tool moves with G0 to safety clearance of the reference point.
2. Inserted into the workpiece with G1 and the programmed feedrate F until the depth or the centering diameter is reached.
3. On expiry of a dwell time DT, the tool is retracted at rapid traverse G0 to the retraction plane.

Procedure



1. The part program or ShopMill program to be processed has been created and you are in the editor.
2. Press the "Drilling" softkey.
3. Press the "Center" softkey.
The "Centering" input window opens.

Parameters, G code program			Parameters, ShopMill program		
PL	Machining plane		T	Tool name	
RP	Retraction plane	mm	D	Cutting edge number	
SC	Safety clearance	mm	F	Feedrate	mm/min mm/rev
			S / V	Spindle speed or constant cutting rate	rpm m/min

Parameter	Description	Unit
Machining position (only for G code)	<ul style="list-style-type: none"> Single position Drill hole at programmed position Position pattern Position with MCALL 	
Z0 (only for G code)	Reference point Z	mm
Centering	<ul style="list-style-type: none"> Diameter (centered with reference to the diameter) The angle for the center drill entered in the tool list is applied. Tip (centered with reference to the depth) The drill is inserted into the workpiece until the programmed insertion depth is reached. 	
∅	It is inserted into the workpiece until the diameter is correct. - (for diameter centering only)	mm
Z1	Drilling depth (abs) or drilling depth in relation to Z0 (inc) It is inserted into the workpiece until it reaches Z1. - (for tip centering only)	mm
DT	<ul style="list-style-type: none"> Dwell time (at final drilling depth) in seconds Dwell time (at final drilling depth) in revolutions 	s rev
Predrilling	<ul style="list-style-type: none"> Yes No 	
ZA	Predrilling depth (abs) or predrilling depth referred to the reference point (inc) - ("yes", only for predrilling)	mm
FA	Predrilling feedrate - ("yes", only for predrilling)	% F7min F/U

8.1 Drilling

8.1.3 Drilling (CYCLE82)

8.1.3.1 Function

Function

With the "Drilling" function, the tool drills with the programmed spindle speed and feedrate down to the specified final drilling depth (shank or tip).

The tool is retracted after a programmed dwell time has elapsed.

Approach/retraction

1. The tool moves with G0 to safety clearance of the reference point.
2. The tool is inserted into the workpiece with G1 and the programmed feedrate F until it reaches the programmed final depth Z1.
3. When a dwell time DT expires, the tool is retracted at rapid traverse G0 to the retraction plane.

Procedure



1. The part program or ShopMill program to be processed has been created and you are in the editor.
2. Press the "Drilling" softkey.











3. Press the "Drilling Reaming" softkey.

4. Press the "Drilling" softkey.



The "Drilling" input window opens.

Parameter G code program			Parameters, ShopMill program		
PL 	Machining plane		T	Tool name	
RP	Retraction plane	mm	D	Cutting edge number	
SC	Safety clearance	mm	F 	Feedrate	mm/min mm/rev
			S / V 	Spindle speed or constant cutting rate	rpm m/min

Parameter	Description	Unit
Machining position  (only for G code)	<ul style="list-style-type: none"> • Single position Drill hole at programmed position • Position pattern Position with MCALL 	
Z0 (only for G code)	Reference point Z	mm
Drilling depth 	<ul style="list-style-type: none"> • Shank (drilling depth in relation to the shank) The drill is inserted into the workpiece until the drill shank reaches the value programmed for Z1. The angle entered in the tool list is taken into account. • Tip (drilling depth in relation to the tip) The drill is inserted into the workpiece until the drill tip reaches the value programmed for Z1. 	
Z1 	Drilling depth (abs) or drilling depth in relation to Z0 (inc) It is inserted into the workpiece until it reaches Z1.	mm
DT 	<ul style="list-style-type: none"> • Dwell time (at final drilling depth) in seconds • Dwell time (at final drilling depth) in revolutions 	s rev
Predrilling	<ul style="list-style-type: none"> • Yes • No 	
ZA 	Predrilling depth (abs) or drilling depth relative to the reference point (inc) - ("yes", only for predrilling)	mm
FA 	Reduced feedrate - ("yes", only for predrilling)	mm/min %
Through drilling 	<ul style="list-style-type: none"> • Yes • No 	
ZD 	Remaining drilling depth referred to the drilling depth (inc) or remaining drilling depth (abs) - ("yes", only for through drilling)	
FD 	Reduced feedrate - ("yes", only for through drilling)	mm/min %

8.1.4 Reaming (CYCLE85)

8.1.4.1 Function

Function

With the "Reaming" cycle, the tool is inserted in the workpiece with the programmed spindle speed and the feedrate programmed at F.

If Z1 has been reached and the dwell time expired, the reamer is retracted at the programmed retraction feedrate to the retraction plane.

Approach/retraction



1. The tool moves with G0 to safety clearance of the reference point.
2. The tool is inserted into the workpiece with the programmed feedrate F until it reaches the final depth Z1.
3. Dwell time DT at final drilling depth.
4. Retraction to retraction plane with programmed retraction feedrate FR.

Procedure



1. The part program or ShopMill program to be processed has been created and you are in the editor.
2. Press the "Drilling" softkey.
3. Press the "Drilling Reaming" softkey.
4. Press the "Reaming" softkey
The "Reaming" input window opens.

Parameters, G code program			Parameters, ShopMill program		
PL	Machining plane		T	Tool name	
RP	Retraction plane	mm	D	Cutting edge number	
SC	Safety clearance	mm	F	Feedrate	mm/min mm/rev
F	Feedrate	*	S / V	Spindle speed or constant cutting rate	rpm m/min

Parameter	Description	Unit
Machining position  (only for G code)	<ul style="list-style-type: none"> • Single position Drill hole at programmed position • Position pattern Position with MCALL 	
Z0 (only for G code)	Reference point Z	mm
FR (only for G code)	Feedrate during retraction	*
FR (only for ShopMill)	Feedrate during retraction	mm/min mm/rev
Z1 	Drilling depth (abs) or drilling depth in relation to Z0 (inc) It is inserted into the workpiece until it reaches Z1. - (for tip centering only)	mm
DT 	<ul style="list-style-type: none"> • Dwell time (at final drilling depth) in seconds • Dwell time (at final drilling depth) in revolutions 	s rev

* Unit of feedrate as programmed before the cycle call

8.1.5 Deep-hole drilling (CYCLE83)

8.1.5.1 Function

Function

With the "Deep-hole drilling" cycle, the tool is inserted in the workpiece with the programmed spindle speed and feedrate in several infeed steps until the depth Z1 is reached. The following can be specified:

- Number of infeed steps constant or decreasing (via programmable degression factor)
- Chip breaking without lifting or swarth removal with tool retraction
- Feedrate factor for 1st infeed to reduce the feedrate or increase the feedrate (e.g. if a hole has already be predrilled)
- Dwell times
- Depth in relation to drill shank of drill tip

Approach/retraction during chipbreaking

1. The tool moves with G0 to safety clearance of the reference point.
2. The tool drills with the programmed spindle speed and feedrate $F = F \cdot FD1$ [%] up to the 1st infeed depth.
3. Dwell time at drilling depth DTB.
4. The tool is retracted by retraction distance V2 for chipbreaking and drills up to the next infeed depth with programmed feedrate F.
5. Step 4 is repeated until the final drilling depth Z1 is reached.
6. Dwell time at final drilling depth DT.
7. The tool retracts to the retraction plane at rapid traverse.

Approach/retraction during stock removal

1. The tool moves with G0 to safety clearance of the reference point.
2. The tool drills with the programmed spindle speed and feedrate $F = F \cdot FD1$ [%] up to the 1st infeed depth.
3. Dwell time at drilling depth DTB.
4. The tool retracts from the workpiece for the stock removal with rapid traverse to the safety clearance.
5. Dwell time at starting point DTS.
6. Approach of the last drilling depth with G0, reduced by the clearance distance V3.
7. Drilling is then continued to the next drilling depth.
8. Steps 4 to 7 are repeated until the programmed final drilling depth Z1 is reached.
9. The tool retracts to the retraction plane at rapid traverse.

Procedure





1. The part program or ShopMill program to be processed has been created and you are in the editor.
2. Press the "Drilling" softkey.
3. Press the "Deep-hole drilling" softkey.
The "Deep-hole Drilling" input window opens.

Parameters, G code program			Parameters, ShopMill program		
PL	Machining plane		T	Tool name	
RP	Retraction plane	mm	D	Cutting edge number	
SC	Safety clearance	mm	F	Feedrate	mm/min mm/rev
			S / V	Spindle speed or constant cutting rate	rpm m/min

Parameter	Description	Unit
Machining position (only for G code)	<ul style="list-style-type: none"> Single position Drill hole at programmed position. Position pattern Position with MCALL 	
Z0 (only for G code)	Reference point Z	mm
Machining	<ul style="list-style-type: none"> Stock removal The drill is retracted from the workpiece for stock removal. Chipbreaking The drill is retracted by the retraction distance V2 for chipbreaking. 	
Drilling depth	<ul style="list-style-type: none"> Shank (drilling depth in relation to the shank) The drill is inserted into the workpiece until the drill shank reaches the value programmed for Z1. The angle entered in the tool list is taken into account. Tip (drilling depth in relation to the tip) The drill is inserted into the workpiece until the drill tip reaches the value programmed for Z1. 	
Z1	Drilling depth (abs) or drilling depth in relation to Z0 (inc) It is inserted into the workpiece until it reaches Z1.	mm
D - (only for G code)	1. Drilling depth (abs) or 1st drilling depth in relation to Z0 (inc)	mm
D - (only for ShopMill)	Maximum depth infeed	mm
FD1	Percentage for the feedrate for the first infeed	%
DF	Infeed: <ul style="list-style-type: none"> Amount for each additional infeed Percentage for each additional infeed DF = 100%: Infeed increment remains constant DF < 100%: Infeed increment is reduced in direction of final drilling depth. Example: Last infeed was 4 mm; DF is 80% next infeed = 4 x 80% = 3.2 mm next infeed = 3.2 x 80% = 2.56 mm etc.	mm %

8.1 Drilling

Parameter	Description	Unit
V1	<p>Minimum infeed - (only for DF in %)</p> <p>Parameter V1 is only provided if DF<100 has been programmed.</p> <p>If the infeed increment becomes very small, a minimum infeed can be programmed in parameter "V1".</p> <p>V1 < Infeed increment: The tool is inserted by the infeed increment</p> <p>V1 > Infeed increment: The tool is inserted by the infeed value programmed under V1.</p>	mm
V2	<p>Retraction distance after each machining step – (for chipbreaking only)</p> <p>Distance by which the drill is retracted for chipbreaking.</p> <p>V2 = 0: The tool is not retracted but is left in place for one revolution.</p>	mm
Clearance distance (for stock removal only)	<ul style="list-style-type: none"> Manual The clearance distance must be entered manually. Automatic The clearance distance is calculated by the cycle. 	
DTB - (only for G code) 	<ul style="list-style-type: none"> Dwell time at drilling depth in seconds Dwell time at drilling depth in revolutions 	s rev
DT 	<ul style="list-style-type: none"> Dwell time at final drilling depth in seconds Dwell time at final drilling depth in revolutions 	s rev
DTS - (only for G code) 	<ul style="list-style-type: none"> Dwell time for stock removal in seconds Dwell time for stock removal in revolutions 	s rev

8.1.6 Boring (CYCLE86)

8.1.6.1 Function

Function

With the "Boring" cycle, the tool approaches the programmed position in rapid traverse, allowing for the retraction plane and safety clearance. It is then inserted into the workpiece at the feedrate programmed under F until it reaches the programmed depth (Z1). There is an oriented spindle stop with the SPOS command. After the dwell time has elapsed, the tool is retracted either with or without lift of the tool.

Note

If, for example, swiveling of mirroring has been performed with CYCLE800 before machining, the SPOS command must be adapted so that the spindle position acts synchronously with DX and DY.

Lift

For "lift off contour", the retraction distance D and the tool orientation angle α can either be defined via machine data or in the parameter screen. If both parameters are pre-assigned via machine data, they do not appear in the parameter screen.



Machine manufacturer

Please refer to the machine manufacturer's specifications.

Note

The "Boring" cycle can be used if the spindle to be used for the boring operation is technically able to go into position-controlled spindle operation.

Approach/retraction

1. The tool moves with G0 to safety clearance of the reference point.
2. Travel to the final drilling depth with G1 and the speed and feedrate programmed before the cycle call.
3. Dwell time at final drilling depth.
4. Oriented spindle hold at the spindle position programmed under SPOS.
5. With the "Lift" selection, the cutting edge retracts from the hole edge with G0 in up to three axes.

8.1 Drilling

6. Retraction with G0 to the safety clearance of the reference point.
7. Retraction to retraction plane with G0 to drilling position in the two axes of the plane (coordinates of the hole center point).

Procedure

1. The part program or ShopMill program to be processed has been created and you are in the editor.



2. Press the "Drilling" softkey.



3. Press the "Boring" softkey.
The "Boring" input window opens.

Parameters, G code program			Parameters, ShopMill program		
PL	Machining plane		T	Tool name	
RP	Retraction plane	mm	D	Cutting edge number	
SC	Safety clearance	mm	F	Feedrate	mm/min mm/rev
			S / V	Spindle speed or constant cutting rate	rpm m/min

Parameter	Description	Unit
Machining position (only for G code)	<ul style="list-style-type: none"> • Single position Drill hole at programmed position • Position pattern Position with MCALL 	
Z0 (only for G code)	Reference point Z	mm
DIR (only for G code)	Direction of rotation <ul style="list-style-type: none"> • • 	
Z1	Drilling depth (abs) or drilling depth in relation to Z0 (inc)	mm
DT	<ul style="list-style-type: none"> • Dwell time at final drilling depth in seconds • Dwell time at final drilling depth in revolutions 	s rev
SPOS	Spindle stop position	Degrees

Parameter	Description	Unit
Lift mode 	<ul style="list-style-type: none"> Do not lift off contour The cutting edge is not fully retracted, but traverses back to the retraction plane. Lift The cutting edge retracts from the edge of the hole and then retracts to the safety clearance from the reference point and then positions at the retraction plane and hole center point. 	
DX (only G Code)	Retraction distance in the X direction (incremental) - (for lift only)	mm
DY (only G code)	Retraction distance in the Y direction (incremental) - (for lift only)	mm
DZ (only G code)	Retraction distance in the Z direction (incremental) - (for lift only)	mm
D (only ShopMill)	Retraction distance (incremental) - (for lift only)	mm

8.1.7 Tapping (CYCLE84, 840)

8.1.7.1 Function

Function

You can machine an internal thread with the "tapping" cycle.

The tool moves to the safety clearance with the active speed and rapid traverse. The spindle stops, spindle and feedrate are synchronized. The tool is then inserted in the workpiece with the programmed speed (dependent on %S).

You can choose between drilling in one cut, chipbreaking or retraction from the workpiece for stock removal.

Depending on the selection in the "Compensating chuck mode" field, alternatively the following cycle calls are generated:

- With compensating chuck: CYCLE840
- Without compensating chuck: CYCLE84

When tapping with compensating chuck, the thread is produced in one cut. CYCLE84 enables tapping to be performed in several cuts, when the spindle is equipped with a measuring system.

Approach/retraction - CYCLE840 - with compensating chuck

1. The tool moves with G0 to safety clearance of the reference point.
2. The tool drills with G1 and the programmed spindle speed and direction of rotation to depth Z1. The feedrate F is calculated internally in the cycle from the speed and pitch.
3. The direction of rotation is reversed.
4. Dwell time at final drilling depth.
5. Retraction to safety clearance with G1.
6. Reversal of direction of rotation or spindle stop.
7. Retraction to retraction plane with G0.

Approach/retraction - CYCLE84 - without compensating chuck

One cut:

1. Travel with G0 to the safety clearance of the reference point.
2. Spindle is synchronized and started with the programmed speed (dependent on %S).
3. Tapping with spindle-feedrate synchronization to Z1.
4. Spindle stop and dwell time at drilling depth.
5. Spindle reverse after dwell time has elapsed.
6. Retraction with active spindle retraction speed (dependent on %S) to safety clearance
7. Spindle stop.
8. Retraction to retraction plane with G0.

Approach/retraction during stock removal

1. The tool drills at the programmed spindle speed S (dependent on %S) as far as the first infeed depth (maximum infeed depth D).
2. Spindle stop and dwell time DT.
3. The tool retracts from the workpiece for the stock removal with spindle speed SR to the safety clearance.
4. Spindle stop and dwell time DT.
5. The tool then drills with spindle speed S as far as the next infeed depth.
6. Steps 2 to 5 are repeated until the programmed final drilling depth Z1 is reached.
7. On expiry of dwell time DT, the tool is retracted with spindle speed SR to the safety clearance. The spindle stops and retracts to the retraction plane.

Approach/retraction during chipbreaking

1. The tool drills at the programmed spindle speed S (dependent on %S) as far as the first infeed depth (maximum infeed depth D).
2. Spindle stop and dwell time DT.
3. The tool retracts by the retraction distance V2 for chipbreaking.
4. The tool then drills to the next infeed depth at spindle speed S (dependent on %S).
5. Steps 2 to 4 are repeated until the programmed final drilling depth Z1 is reached.
6. On expiry of dwell time DT, the tool is retracted with spindle speed SR to the safety clearance. The spindle stops and retracts to the retraction plane.



Machine manufacturer

Please refer to the machine manufacturer's specifications.

Procedure







1. The part program or ShopMill program to be processed has been created and you are in the editor.
2. Press the "Drilling" softkey.
3. Press the "Thread" and "Tap" softkeys. The "tapping" input window opens.









Parameters, G code program			Parameters, ShopMill program		
PL	Machining plane		T	Tool name	
RP	Retraction plane	mm	D	Cutting edge number	
SC	Safety clearance	mm	S / V	Spindle speed or constant cutting rate	rpm m/min

8.1 Drilling

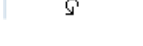
Parameter	Description	Unit
Compensating chuck mode U	<ul style="list-style-type: none"> With compensating chuck Without compensating chuck 	
Machining position U (only for G code)	<ul style="list-style-type: none"> Single position Drill hole at programmed position Position pattern Position with MCALL 	
Z0 (only for G code)	Reference point Z	mm
Z1 U	End point of the thread (abs) or thread length (inc) It is inserted into the workpiece until it reaches Z1.	mm
Machining - (with compensating chuck) (only for G code) U	<p>You can select the following technologies for tapping:</p> <ul style="list-style-type: none"> With encoder Tapping with spindle encoder Without encoder Tapping without spindle encoder; selection: - Define "Pitch" parameter 	
SR (only for ShopMill)	Spindle speed for retraction - (only for S)	rev/min
VR (only for ShopMill)	Constant cutting rate for retraction (only for V)	m/min
Pitch - (only machining without encoder) (only for G code) U	<ul style="list-style-type: none"> User input Pitch results from the input Active feedrate Pitch results from the feedrate 	
Thread U (only for G code)	<p>Direction of rotation of the thread</p> <ul style="list-style-type: none"> Right-hand thread Left-hand thread <p>(only in mode "without compensating chuck")</p>	
Table U	<p>Thread table selection:</p> <ul style="list-style-type: none"> Without ISO metric Whitworth BSW Whitworth BSP UNC 	

Parameter	Description	Unit
Selection 	Selection of table value: e.g. <ul style="list-style-type: none"> M3; M10; etc. (ISO metric) W3/4"; etc. (Whitworth BSW) G3/4"; etc. (Whitworth BSP) 1" - 8 UNC; etc. (UNC) 	
P  - (selection option only for table selection "without")	Pitch ... <ul style="list-style-type: none"> in MODULUS: MODULUS = Pitch/π in turns per inch: Used with pipe threads, for example. <p>When entered per inch, enter the integer number in front of the decimal point in the first parameter field and the figures after the decimal point as a fraction in the second and third field.</p> <ul style="list-style-type: none"> in mm/rev in inch/rev <p>The pitch is determined by the tool used.</p>	MODULUS Turns/" mm/rev in/rev
α S (only for G code)	Starting angle offset - (for rigid tapping only)	Degrees
S (only for G code)	Spindle speed - (for rigid tapping only)	rev/min
Machining  (not for G code "with compensating chuck")	The following machining operations can be selected: <ul style="list-style-type: none"> 1 cut The thread is drilled in one cut without stopping Chipbreaking The drill is retracted by the retraction amount V2 for chipbreaking. Stock removal The drill is retracted from the workpiece for stock removal. 	
D	Maximum depth infeed - (only when used without compensating chuck, stock removal or chipbreaking)	mm
Retraction 	Retraction distance - (for chipbreaking only) <ul style="list-style-type: none"> Manual Retraction distance after each machining step (V2) Automatic Without retraction distance after each machining step 	
V2	Retraction distance after each machining step – (only without compensating chuck, chipbreaking and manual retraction) Distance by which the drill is retracted for chipbreaking. V2 = automatic: The tool is retracted by one revolution.	mm
DT (only for G code)	Dwell time at final drilling depth in seconds	s
SR (only for G code)	Spindle speed for retraction - (only for when a compensating chuck is not used)	rev/min

8.1 Drilling

Parameter	Description	Unit
SDE  (only for G code)	Direction of rotation after end of cycle: <ul style="list-style-type: none">    	
Technology 	<ul style="list-style-type: none"> Yes <ul style="list-style-type: none"> Exact stop Precontrol Acceleration Spindle No 	
Exact stop (only for technology, yes) 	<ul style="list-style-type: none"> Behavior the same as it was before the cycle was called G601: Block advance for exact stop fine G602: Block advance for exact stop coarse G603: Block advance if the setpoint has been reached 	
Precontrol (only for technology, yes) 	<ul style="list-style-type: none"> Behavior the same as it was before the cycle was called FFWON: with precontrol FFWOF: without precontrol 	
Acceleration (only for technology, yes) 	<ul style="list-style-type: none"> Behavior the same as it was before the cycle was called SOFT: Jerk-limited (soft) acceleration of the axes BRISK: Abrupt acceleration of the axes DRIVE: Reduced axis acceleration 	
Spindle (only for technology, yes) 	<ul style="list-style-type: none"> Speed controlled: Spindle for MCAL; speed controlled operation Position controlled: Spindle for MCALL; position controlled operation 	

8.1.8 Drill and thread milling (CYCLE78)

8.1.8.1 Function

Function

You can use a drill and thread milling cutter to manufacture an internal thread with a specific depth and pitch in one operation. This means that you can use the same tool for drilling and thread milling, a change of tool is superfluous.

The thread can be machined as a right- or left-hand thread.

Approach/retraction

1. The tool traverses with rapid traverse to the safety clearance.
2. If pre-drilling is required, the tool traverses at a reduced drilling feedrate to the predrilling depth defined in a setting data (ShopMill/ShopTurn). When programming in G code, the predrilling depth can be programmed using an input parameter.



Machine manufacturer

Please also refer to the machine manufacturer's instructions.

1. The tool bores at drilling feedrate F1 to the first drilling depth D. If the final drilling depth Z1 is not reached, the tool will travel back to the workpiece surface in rapid traverse for stock removal. Then the tool will traverse with rapid traverse to a position 1 mm above the drilling depth previously achieved - allowing it to continue drilling at drill feedrate F1 at the next infeed. Parameter "DF" is taken into account from the 2nd infeed and higher (refer to the table "Parameters").
2. If another feedrate FR is required for through-boring, the residual drilling depth ZR is drilled with this feedrate.
3. If required, the tool traverses back to the workpiece surface for stock removal before thread milling with rapid traverse.
4. The tool traverses to the starting position for thread milling.
5. The thread milling is carried out (climbing, conventional or conventional + climbing) with milling feedrate F2. The thread milling acceleration path and deceleration path is traversed in a semicircle with concurrent infeed in the tool axis.

8.1 Drilling

Procedure



1. The part program or ShopMill program to be processed has been created and you are in the editor.
2. Press the "Drilling" softkey.
3. Press the "Thread" and "Drill and thread mill" softkeys. The "Drilling and thread milling" input window opens.

Parameters, G code program			Parameters, ShopMill program		
PL	Machining plane		T	Tool name	
RP	Retraction plane	mm	D	Cutting edge number	
SC	Safety clearance	mm	F	Feedrate	mm/min mm/rev
			S / V	Spindle speed or constant cutting rate	rpm m/min

Parameter	Description	Unit
Machining position (only for G code)	<ul style="list-style-type: none"> • Single position Drill hole at programmed position • Position pattern Position with MCALL 	
F1 (only for G-code)	Drilling feedrate	mm/min mm/rev
Z0 (only for G code)	Reference point Z	mm
Z1	Thread length (inc) or end point of the thread (abs)	mm
D	Maximum depth infeed <ul style="list-style-type: none"> • $D \geq Z1$: Infeed to the final drilling depth • $D < Z1$: Several infeeds with stock removal 	mm

8.1 Drilling

Parameter	Description	Unit
Table U	Thread table selection: <ul style="list-style-type: none"> without ISO metric Whitworth BSW Whitworth BSP UNC 	
Selection - (not for table "Without") U	Selection of table value: e.g. <ul style="list-style-type: none"> M3; M10; etc. (ISO metric) W3/4"; etc. (Whitworth BSW) G3/4"; etc. (Whitworth BSP) N1" - 8 UNC; etc. (UNC) 	
P U - (selection option only for table selection "without")	Pitch ... <ul style="list-style-type: none"> in MODULUS: $MODULUS = Pitch/\pi$ in turns per inch: Used with pipe threads, for example. <p>When entered per inch, enter the integer number in front of the decimal point in the first parameter field and the figures after the decimal point as a fraction in the second and third field.</p> <ul style="list-style-type: none"> in mm/rev in inch/rev <p>The pitch is determined by the tool used.</p>	MODULUS Turns/" mm/rev in/rev
Z2	Retraction amount before thread milling The thread depth in the direction of the tool axis is defined using Z2. Z2 is relative to the tool tip.	mm
Ø	Nominal diameter	mm
Milling direction U	<ul style="list-style-type: none"> Climb milling: Mill thread in one cycle. Up-cut operation milling: Mill thread in one cycle. Synchronous operation - Up-cut operation: Mill thread in two cycles: rough cutting is performed by Up-cut operation milling with defined allowances, then finish cutting is performed by climb milling with milling feedrate FS. 	
FS U	Finishing feedrate - (only for Synchronous operation - Up-cut operation milling)	mm/min mm/tooth

8.1.9 Positioning and position patterns

Function

After you have programmed the technology (cycle call), you must program the positions. Several position patterns are available:

- Arbitrary positions
- Position on a line, on a grid or frame
- Position on a full or pitch circle

Several position patterns can be programmed in succession. They are executed in the order in which you program them.

Note

The number of positions that can be programmed in the one "Positions" step is limited to a maximum of 400!

Programming a position pattern in ShopMill

Several position patterns can be programmed in succession (up to 20 technologies and position patterns in total). They are executed in the order in which you program them.

The programmed technologies and subsequently programmed positions are automatically linked by the control.

Displaying and hiding positions

You can display or hide any positions(Chapter "Displaying and hiding positions").

Rotary axis

If an A or B axis is set up on your machine, this is supported during drilling (any position pattern, full circle, and pitch circle).

You set as to which rotary axis is listed as selection in position patterns.



Machine manufacturer

Please refer to the machine manufacturer's specifications.

If the machine has an A or B axis, it makes sense to define a work offset with

X / Y = end face of the cylinder (X for an A axis / Y for a B axis)

X / Y = center point of the cylinder (Y for an A axis / X for a B axis)

8.1 Drilling

Z = center point of the cylinder

The "cylinder" in this case refers to any part that is clamped in the A/B axis.

Cylinder surface transformation

When working with the cylinder surface transformation, please note that the A axis or B axis is not supported in all cases. Programming of any position in the XYA plane is not possible while cylinder surface transformation is active.

Note

A work offset in the rotary axis A or B is effective even while cylinder surface transformation is active.

Approach/retraction

1. Within a position pattern, or while approaching the next position pattern, the tool is retracted to the retraction plane and the new position or position pattern is then approached at rapid traverse.
2. With technological follow-up operations (e.g. centering - drilling - tapping), the respective drilling cycle must be programmed after calling the next tool (e.g. drill) and immediately afterwards the call of the position pattern to be machined.

Tool traverse path

- ShopMill

The programmed positions are machined with the previously programmed tool (e.g. center drill). Machining of the positions always starts at the reference point. In the case of a grid, machining is performed first in the direction of the 1st axis and then meandering back and forth. The frame and hole circle are machined counterclockwise.

- G codes

For G code, for lines/frames/grids, a start is always made at the next corner of the frame or grid or the end of the row. The frame and hole circle are machined counterclockwise.

8.1.10 Arbitrary positions (CYCLE802)

Function

The "Arbitrary positions" cycle allows you to program positions freely, i.e. rectangular or polar. Individual positions are approached in the order in which you program them. Press softkey "Delete all" to delete all positions programmed in X/Y.

Rotary axis

XA plane

You program in XA to prevent the Y axis moving during machining.

To ensure that the holes point to the center of the "Cylinder", you must first position the Y axis centrally above the "Cylinder".

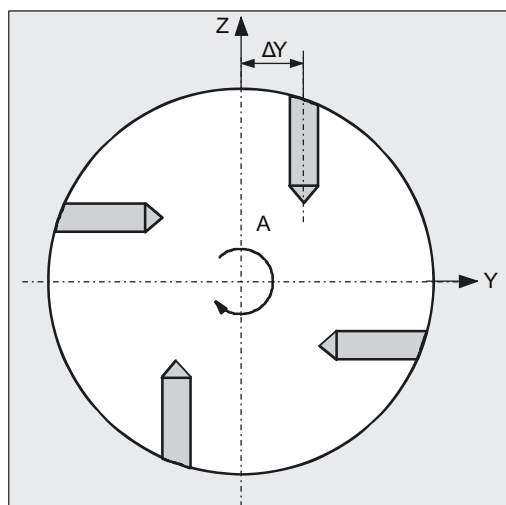
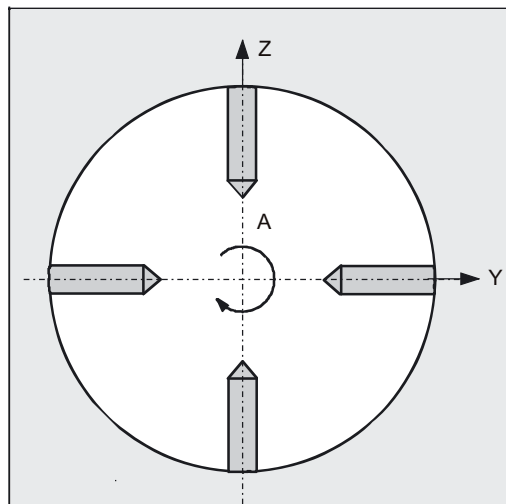

XYA plane



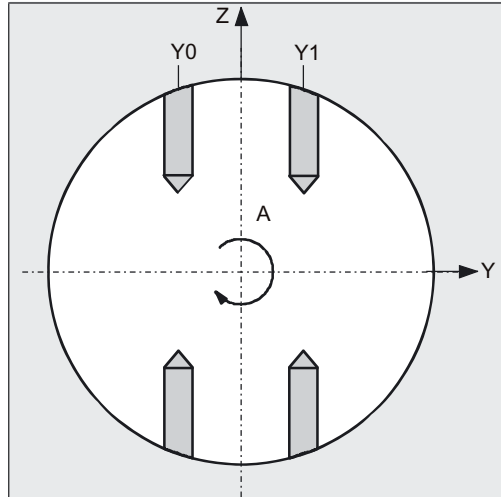















You program in XYA if the Y axis should also move during machining. A value can be specified for each position. In addition to the possibilities of XA, the following is also possible, for example.



















Procedure



1. The part program or ShopMill program to be processed has been created and you are in the editor.
2. Press the "Drilling" softkey.
3. Press the "Positions" softkey.
The "Positions" input window opens.

Parameter	Description	Unit
LAB - (only for G code)	Repeat jump label for position	
PL  - (only for G code)	Machining plane	
Axes 	<p>Selection of the participating axes</p> <ul style="list-style-type: none"> • XY (1st and 2nd axis of the plane) • XA (1st rotary axis and assigned linear axis) • XYA (1st rotary axis and both axes of the plane) • YB (2nd rotary axis and assigned linear axis) • XYB (2nd rotary axis and both axes of the plane) <p>Note: Rotary axes are only displayed in the selection field if they have been released for use in the position pattern. Please observe the information provided by your machine manufacturer.</p>	
Selection 	<p>Coordinate system (only available for axis selection XY)</p> <ul style="list-style-type: none"> • Right-angled • Polar 	mm
Z0	Z coordinate of the reference point (abs)	mm
XP YP L0 C0 L1  ... L7  C1  ... C7 	<p>Axes: XY / coordinate system – polar</p> <p>X coordinate of the reference point – pole (abs)</p> <p>Y coordinate of the reference point – pole (abs)</p> <p>Length (abs) – distance of the 1st Position from the pole</p> <p>Angle (abs) – Angle of the 1st position referred to the reference axis</p> <p>Lengths of additional positions (abs or inc)</p> <p>Angles of additional positions (abs or inc)</p>	mm mm mm Degrees mm Degrees
(only for ShopMill) X0 Y0 X1  ... X8  Y1  ... Y8 	<p>Axes: XY / coordinate system – right angled</p> <p>X coordinate of the 1st position (abs)</p> <p>Y coordinate of the 1st position (abs)</p> <p>X coordinate for further positions (abs. or inc.)</p> <p>Y coordinate for further positions (abs. or inc.)</p>	mm mm mm mm
(only for G code) X0 Y0 X1  ... X8  Y1  ... Y8 	<p>(only "right angled")</p> <p>X coordinate of the 1st position (abs)</p> <p>Y coordinate of the 1st position (abs)</p> <p>X coordinate of additional positions (abs or inc)</p> <p>Y coordinate of additional positions (abs or inc)</p>	mm mm mm mm
X0 A0 X1  ... X8  A1  ... A8 	<p>Axes: XA</p> <p>X coordinate of the 1st position (abs)</p> <p>A coordinate (angle) of the 1st position (abs)</p> <p>X coordinates of additional positions (abs or inc)</p> <p>A coordinates (angle) of additional positions (abs or inc)</p>	mm Degrees mm mm

8.1 Drilling

Parameter	Description	Unit
Y0	Axes: YB Y coordinate of the 1st position (abs)	mm
B0	B coordinate (angle) of the 1st position (abs)	Degrees
Y1  ... Y8 	Y coordinates of additional positions (abs or inc)	mm
B1  ... B8 	B coordinates (angle) of additional positions (abs or inc)	mm
X0	Axes: XYA X coordinate of the 1st position (abs)	mm
Y0	Y coordinate of the 1st position (abs)	mm
A0	A coordinate (angle) of the 1st position (abs)	Degrees
X1  ... X5 	X coordinates of additional positions (abs or inc)	mm
Y1  ... Y5 	Y coordinates of additional positions (abs or inc)	mm
A1  ... A5 	A coordinates (angle) of additional positions (abs or inc)	Degrees
X0	Axes: XYB X coordinate of the 1st position (abs)	mm
Y0	Y coordinate of the 1st position (abs)	mm
B0	B coordinate (angle) of the 1st position (abs)	Degrees
X1  ... X5 	X coordinates of additional positions (abs or inc)	mm
Y1  ... Y5 	Y coordinates of additional positions (abs or inc)	mm
B1  ... B5 	B coordinates (angle) of additional positions (abs or inc)	Degrees

8.1.11 Position pattern line (HOLES1), grid or frame (CYCLE801)

Function



You can program the following pattern using the "Position pattern" cycle:

- Line (HOLES1)
In the "Line" selection option you can program any number of positions at equal distances along a line.
- Grid (CYCLE801)
You can use the "Grid" selection option to program any number of positions spaced at an equal distance along one or several parallel lines.
If you want to program a rhombus-shaped grid, enter angle αX or αY .
- Frame (CYCLE801)
You can use the "Frame" selection option to program any number of positions spaced at an equal distance on a frame. The spacing may be different on both axes.
If you want to program a rhombus-shaped frame, enter angle αX or αY .

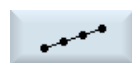
Procedure



1. The part program or ShopMill program to be processed has been created and you are in the editor.
2. Press the "Drilling" softkey.
3. Press the "Positions" and "Line" softkeys.
The "Position pattern" input window opens.

Parameter	Description	Unit
LAB (only for G code)	Repeat jump label for position	
PL  (only for G code)	Machining plane	
Position pattern  (only for G code)	Selection option for the following patterns: <ul style="list-style-type: none"> • Line • Grid • Frame 	

8.1 Drilling

Parameter	Description	Unit
Z0 (only for ShopMill)	Z coordinate of reference point Z (abs)	mm
X0	X coordinate of the reference point X (abs) This position must be programmed absolutely in the 1st call.	mm
Y0	Y coordinate of the reference point Y (abs) This position must be programmed absolutely in the 1st call.	mm
$\alpha 0$	Angle of rotation of the line referred to the X axis Positive angle: Line is rotated counter-clockwise. Negative angle: Line is rotated clockwise.	Degrees
L0	Line Distance of the 1st position to reference point	mm
L	Distance between the positions	mm
N	Number of positions	
αX	Grid or frame Shear angle X	Degrees
αY	Shear angle Y	Degrees
L1	Distance between columns	mm
L2	Distance between rows	mm
N1	Number of columns	
N2	Number of rows	

8.1.12 Circle position pattern (HOLES2)

Function

You can program holes on a full circle or pitch circle with defined radius with the "Circle position pattern" cycle. The basic angle of rotation (α_0) for the 1st position is relative to the X axis. The control calculates the angle of the next hole position as a function of the total number of holes. The angle it calculates is identical for all positions.

The tool can approach the next position along a linear or circular path.

Procedure



1. The part program or ShopMill program to be processed has been created and you are in the editor.
2. Press the "Drilling" softkey.

3. Press the "Positions" and "Circle" softkeys.





The "Position circle" input window opens.

Parameter	Description	Unit
LAB (only for G code)	Repeat jump label for position	
PL  (only for G code)	Machining plane	
Axes  (only for ShopMill)	Selection of the participating axes <ul style="list-style-type: none"> • XY (1st and 2nd axis of the plane) • XA (1st rotary axis and assigned linear axis) • YB (2nd rotary axis and assigned linear axis) Note: Rotary axes are only displayed in the selection field if they have been released for use in the position pattern. Please observe the information provided by your machine manufacturer.	
Circular pattern 	Selection option for the following patterns: <ul style="list-style-type: none"> • Pitch circle • Full circle 	
Z0 (only for ShopMill)	Z coordinate of the reference point	mm

8.1 Drilling

Parameter	Description	Unit
	For G code and ShopMill – axes XY (right angled)	
X0	X coordinate of the reference point X (abs)	mm
Y0	Y coordinate of the reference point Y (abs)	mm
$\alpha 0$	Starting angle for first position. Positive angle: Full circle is rotated counter-clockwise. Negative angle: Full circle is rotated in clockwise direction.	Degrees
$\alpha 1$	Advance angle - (for pitch circle pattern only) After the first hole has been drilled, all further positions are advanced by this angle. Positive angle: Further positions are rotated counter-clockwise. Negative angle: Further positions are rotated clockwise.	Degrees
R	Radius	mm
N	Number of positions	
Positioning	Positioning motion between the positions	
	<ul style="list-style-type: none"> Straight line Next position is approached linearly in rapid traverse. Circle Next position is approached along a circular path at the feedrate defined in the machine data. 	
(only for ShopMill)	Axes: XA	
X0	X coordinate of the reference point (abs)	mm
A0	Start angle of the A axis (abs)	Degrees
A1	Advance angle of the A axis (inc) - (for pitch circle pattern only)	Degrees
N	Number of positions	
(only for ShopMill)	Axes: YB	
Y0	Y coordinate of the reference point (abs)	mm
B0	Start angle of the B axis (abs)	Degrees
B1	Advance angle of the B axis (inc) - (for pitch circle pattern only)	Degrees
N	Number of positions	

8.1.13 Displaying and hiding positions

Function

You can hide any positions in the following position patterns:

- Position pattern line
- Position pattern grid
- Position pattern frame
- Full circle position pattern
- Pitch circle position pattern

The hidden positions are skipped when machining.

Display

The programmed positions of the position pattern are shown as follows in the programming graphic:

- x Position is activated = displayed (position is shown as a cross)
- o Position deactivated = hidden (position shown as a circle)

Selecting positions

You have the option of either displaying or hiding positions - by activating the checkbox in the displayed position table either using the keyboard or mouse.

Procedure

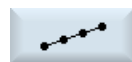

1. The part program or ShopMill program to be processed has been created and you are in the editor.
2. Press the "Drilling" and "Positions" softkeys.
3. Press the "Line/Grid/Frame" or "Full/Pitch Circle" softkeys.

8.1 Drilling



4. Press the "Hide position" softkey.
The "Hide position" window opens on top of the input form of the position pattern. The positions are displayed in a table.
The numbers of the positions, their angle(α) as well as a checkbox with the state (activated = check mark set / deactivated = no check mark set) are displayed.
The selected position in the graphic is highlighted in color.
5. Using the mouse, select the required position and deactivate or activate the checkbox in order to hide the position or display it again.
In the diagram, skipped positions are shown in the form of a circle and displayed (active) positions are shown in the form of a cross.
Note: You have the option of selecting individual positions using the <Cursor up> or <Cursor down> keys – and hiding and displaying using the <SELECT> key.

Display or hide all positions at once



1. Press the "Hide all" softkey to hide all positions.



2. Press the "Show all" softkey to display all positions again.

8.1.14 Repeating positions

Function

If you want to approach positions that you have already programmed again, you can do this quickly with the function "Repeat position".

You must specify the number of the position pattern. The cycle automatically assigns this number (for ShopMill). You will find this position pattern number in the work plan (program view) or G-code program after the block number.

Procedure



1. The part program or ShopMill program to be processed has been created and you are in the editor.
2. Press the "Drilling", and "Repeat position" softkeys.
The "Repeat positions" input window opens.
3. After you have entered the label or the position pattern number, e.g. 1, press the "Accept" softkey. The position pattern you have selected is then approached again.

Parameter	Description	Unit
LAB (only for G code)	Repeat jump label for position	
Position (only for ShopMill)	Enter the number of the position pattern	

8.2 Milling

8.2.1 Face milling (CYCLE61)

8.2.1.1 Function

Function

You can face mill any workpiece with the "Face milling" cycle.

A rectangular surface is always machined.

Workpieces with and without limits can be face-milled.

Approach/retraction

1. For vertical machining, the starting point is always at the top or bottom. For horizontal machining, it is at the left or right.

The starting point is marked in the help display.

2. Machining is performed from the outside to the inside.

Machining type

The cycle makes a distinction between roughing and finishing:

- Roughing:
 - Milling the surface
 - Tool turns above the workpiece edge
- Finishing:
 - Milling the surface once
 - Tool turns at safety distance in the X/Y plane
 - Retraction of milling cutter

Depth infeed always takes place outside the workpiece.

For a workpiece with edge breaking, select the rectangular spigot cycle.

In face milling, the effective tool diameter for a tool of type "Milling cutter" is stored in a machine data item.



Machine manufacturer

Please refer to the machine manufacturer's specifications.

Selecting the machining direction

Toggle the machining direction in the "Direction" field until the symbol for the required machining direction appears.

- Same direction of machining
- Alternating direction of machining

Selecting limits

Press the respective softkey for the required limit.

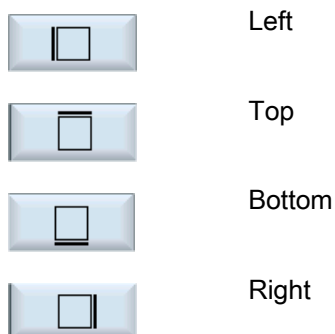

The selected limits are shown in the help screen and in the broken-line graphics.



Procedure











1. The part program or ShopMill program to be processed has been created and you are in the editor.
2. Press the "Milling" softkey.

3. Press the "Face milling" softkey.



The "Face Milling" input window opens.

Parameters, G code program			Parameters, ShopMill program		
PL	Machining plane		T	Tool name	
					
RP	Retraction plane	mm	D	Cutting edge number	
SC	Safety clearance	mm	F	Feedrate	mm/min mm/tooth
					
F	Feedrate	*	S / V	Spindle speed or constant cutting rate	rpm m/min
					

Parameter	Description	Unit
Machining 	The following machining operations can be selected: <ul style="list-style-type: none"> ▽ (roughing) ▽▽▽ (finishing) 	
Direction 	Same direction of machining <ul style="list-style-type: none">   Alternating direction of machining <ul style="list-style-type: none">   	
X0 Y0 Z0	The positions refer to the reference point: Corner point 1 in X Corner point 1 in Y Height of blank	mm mm mm
X1  Y1  Z1 	Corner point 2X (abs) or corner point 2X in relation to X0 (inc) Corner point 2Y (abs) or corner point 2Y in relation to Y0 (inc) Height of blank (abs) or height of blank in relation to Z0 (inc)	mm mm mm
DXY 	Maximum plane infeed Alternately, you can specify the plane infeed in %, as a ratio → plane infeed (mm) to the milling cutter diameter (mm).	mm %
DZ	Maximum depth infeed – (for roughing only)	mm
UZ	Finishing allowance, depth	mm

* Unit of feedrate as programmed before the cycle call

Note

The same finishing allowance must be entered for both roughing and finishing. The finishing allowance is used to position the tool for retraction.

8.2.2 Rectangular pocket (POCKET3)

Function

You can mill any rectangular pocket with the "rectangular pocket milling" function.

The following machining variants are available:

- Mill rectangular pocket from solid material.
- Predrill rectangular pocket in the center first if, for example, the milling cutter does not cut in the center (program the drilling, rectangular pocket and position program blocks in succession).
- Machine pre-machined rectangular pocket (see "Solid machining" parameter):
 - Complete machining
 - Post machining

Depending on the dimensions of the rectangular pocket in the workpiece drawing, you can select a corresponding reference point for the rectangular pocket.

Note

Predrilling

If the programmed input parameters, deviating from Pocket3, result in a longitudinal slot or a longitudinal hole, then in the cycle, from Pocket3, the corresponding cycle to machine slots (Slot1 or Longhole) is called. In cases such as these, the points of insertion (plunge points) can deviate from the pocket center point.

Observe this special feature if you wish to predrill.

Approach/retraction

1. The tool approaches the center point of the rectangular pocket in rapid traverse at the height of the retraction plane and adjusts to the safety clearance.
2. The tool is inserted into the material according to the chosen strategy.
3. The rectangular pocket is always machined with the chosen machining type from inside out.
4. The tool moves back to the safety clearance at rapid traverse.

Machining type

- **Roughing**
During roughing, the individual planes of the rectangular pocket are machined one after the other from the center point until depth Z1 is reached.
- **Finishing**
During finishing, the edge is always machined first. The rectangular pocket edge is approached on the quadrant that joins the corner radius. In the last infeed, the base is finished from the center out.
- **Edge finishing**
Edge finishing is performed in the same way as finishing, except that the last infeed (finish base) is omitted.
- **Chamfering**
Chamfering involves edge breaking at the upper edge of the rectangular pocket.

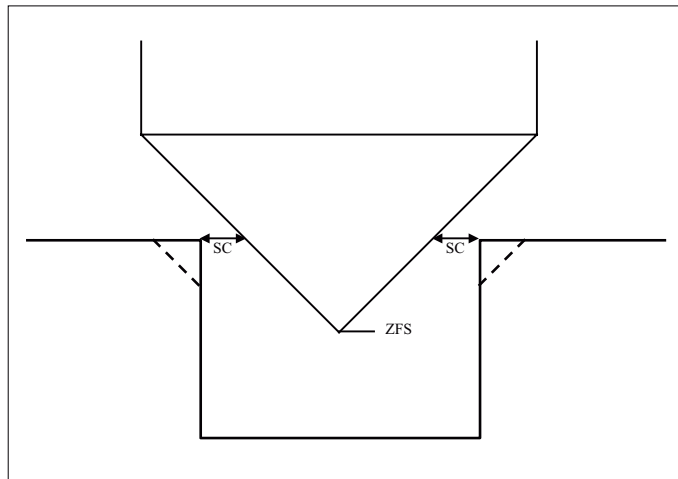

Figure 8-1 Geometries when chamfering inside contours

Note

The following error messages can occur when chamfering inside contours:

- **Safety clearance in the program header too large**
This error message appears when chamfering would, in principle, be possible with the parameters entered for FS and ZFS, but the safety clearance then could not be maintained.
- **Immersion depth too large**
This error message appears when chamfering would be possible through the reduction of the immersion depth ZFS.
- **Tool diameter too large**
This error message appears when the tool would already damage the edges during insertion. In this case, the chamfer FS must be reduced.





Procedure



1. The part program or ShopMill program to be processed has been created and you are in the editor.
2. Press the "Milling" softkey.
3. Press the "Pocket" and "Rectangular pocket" softkeys.
The "Rectangular pocket" input window opens.



Parameters, G code program			Parameters, ShopMill program		
PL 	Machining plane		T	Tool name	
	Milling direction		D	Cutting edge number	
RP	Retraction plane	mm	F 	Feedrate	mm/min mm/tooth
SC	Safety clearance	mm	S / V 	Spindle speed or constant cutting rate	rpm m/min
F	Feedrate	*			

Parameter	Description	Unit
Reference point 	<p>The following different reference point positions can be selected:</p> <ul style="list-style-type: none"> • (center) • (bottom left) • (bottom right) • (top left) • (top right) <p>The reference point (highlighted in blue) is displayed in the Help screen.</p>	
Machining 	<p>The following machining operations can be selected:</p> <ul style="list-style-type: none"> • ▽ (roughing) • ▽▽▽ (finishing) • ▽▽▽ edge (edge finishing) • Chamfering 	

Parameter	Description	Unit
Machining position 	<ul style="list-style-type: none"> Single position Mill rectangular pocket at the programmed position (X0, Y0, Z0). Position pattern Position with MCALL 	
X0	The positions refer to the reference point: Reference point X – (single position only)	mm
Y0	Reference point Y – (single position only)	mm
Z0	Reference point Z – (only single position and G Code position pattern)	mm
W	Pocket width	mm
L	Pocket length	mm
R	Corner radius	mm
α0	Angle of rotation	Degrees
Z1 	Depth referred to Z0 (inc) or pocket depth (abs) - (only for ▽, ▽▽▽ or ▽▽▽ edge)	mm
DXY 	<ul style="list-style-type: none"> Maximum plane infeed Maximum plane infeed as a percentage of the milling cutter diameter - (only for ▽ and ▽▽▽) 	mm %
DZ	Maximum depth infeed – (only for ▽, ▽▽▽ or ▽▽▽ edge)	mm
UXY	Plane finishing allowance – (only for ▽, ▽▽▽ or ▽▽▽ edge)	mm
UZ	Depth finishing allowance – (only for ▽ or ▽▽▽)	mm
Insertion 	<p>The following insertion modes can be selected – (only for ▽, ▽▽▽ or ▽▽▽ edge):</p> <ul style="list-style-type: none"> Predrilled: (only for G code) With G0, the pocket center point is approached at the retraction plane level, and then, from this position, also with G0, the axis travels to the reference point brought forward by the safety clearance. The machining of the rectangular pocket is then performed according to the selected insertion strategy, taking into account the programmed blank dimensions. Perpendicular: Insert vertically at the center of pocket The tool executes the calculated actual depth infeed at the pocket center in a single block. This setting can be used only if the cutter can cut across center or if the pocket has been predrilled. Helical: Insert along helical path The cutter center point traverses along the helical path determined by the radius and depth per revolution (helical path). If the depth for one infeed has been reached, a full circle motion is executed to eliminate the inclined insertion path. Oscillating: Insert with oscillation along center axis of rectangular pocket The cutter center point oscillates back and forth along a linear path until it reaches the depth infeed. When the depth has been reached, the path is traversed again without depth infeed in order to eliminate the inclined insertion path. 	
FZ (only for G code)	Depth infeed rate – (for vertical insertion only)	*

Parameter	Description	Unit
FZ  (only for ShopMill)	Depth infeed rate – (for vertical insertion only)	mm/min mm/tooth
EP	Maximum pitch of helix – (for helical insertion only)	mm/rev
ER	Radius of helix – (for helical insertion only) The radius cannot be any larger than the cutter radius; otherwise, material will remain.	mm
EW	Maximum insertion angle – (for insertion with oscillation only)	Degrees
Solid machining (for roughing only) 	<ul style="list-style-type: none"> • Complete machining The rectangular pocket is milled from the solid material. • Post machining A rectangular pocket or hole has already been machined in the workpiece. This needs to be enlarged in one or several axes. You must program parameters AZ, W1 and L1 for this purpose. 	
AZ	Depth of premachining – (for remachining only)	mm
W1	Width of premachining – (for remachining only)	mm
L1	Length of premachining – (for remachining only)	mm
FS	Chamfer width for chamfering - (for chamfering only)	mm
ZFS 	Insertion depth of tool tip (abs or inc) – (for chamfer only)	mm

* Unit of feedrate as programmed before the cycle call

8.2.3 Circular pocket (POCKET4)

Function

You can mill any circular pocket with the "Circular pocket" cycle.

The following machining methods are available:

- Mill circular pocket from solid material.
- Predrill circular pocket in the center first if, for example, the milling cutter does not cut in the center (program the drilling, circular pocket and position program blocks in succession).
- Machine pre-machined circular pocket (see "Solid machining" parameter).
 - Complete machining
 - Post machining

The following machining types are available for milling using the "Circular pocket" function:

- Plane-by-plane
- Helical

Approach/retraction for plane-by-plane solid machining

In plane-by-plane machining of the circular pocket, the material is removed horizontally, one layer at a time.

1. The tool approaches the center point of the pocket at rapid traverse at the height of the retraction plane and adjusts to the safety clearance.
2. The tool is inserted into the material according to the chosen strategy.
3. The circular pocket is always machined from inside out using the selected machining method.
4. The tool moves back to the safety clearance at rapid traverse.

Approach/retraction for helical solid machining

In helical reaming, the material is removed down to pocket depth in a helical movement.

1. The tool approaches the center point of the pocket at rapid traverse at the height of the retraction plane and adjusts to the safety clearance.
2. Infeed to the first machining diameter.
3. The circular pocket is machined with the chosen machining type up to pocket depth or up to pocket depth with finishing allowance.
4. The tool moves back to the safety clearance at rapid traverse.
5. Lateral infeed to the next machining diameter.

Machining type: Plane-by-plane

When milling circular pockets, you can select the following machining types:

- Roughing

During roughing, the individual planes of the circular pocket are machined one after the other from center point until depth Z1 is reached.

- Finishing

During finishing, the edge is always machined first. The pocket edge is approached on the quadrant that joins the pocket radius. In the last infeed, the base is finished from the center out.

- Edge finishing

Edge finishing is performed in the same way as finishing, except that the last infeed (finish base) is omitted.

- Chamfering

Chamfering involves edge breaking at the upper edge of the circular pocket.

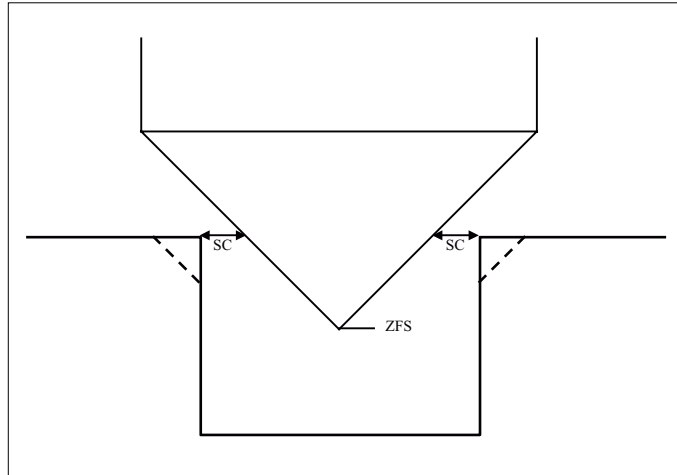

Figure 8-2 Geometries when chamfering inside contours

Note

The following error messages can occur when chamfering inside contours:

- **Safety clearance in the program header too large**
This error message appears when chamfering would, in principle, be possible with the parameters entered for FS and ZFS, but the safety clearance then could not be maintained.
 - **Immersion depth too large**
This error message appears when chamfering would be possible through the reduction of the immersion depth ZFS.
 - **Tool diameter too large**
This error message appears when the tool would already damage the edges during insertion. In this case, the chamfer FS must be reduced.
-

Machining type: Helical

When milling circular pockets, you can select the following machining types:

- Roughing

During roughing, the circular pocket is machined downward with helical movements.

A full circle is effected down to pocket depth to remove the residual material.

The tool is retracted from the edge and base of the pocket in a quadrant and retracted with rapid traverse to a safety clearance.

This process is repeated layer-by-layer, from inside out, until the circular pocket has been completely machined.

- Finishing

In finishing mode, the edge is machined first with a helical movement down to the bottom.

A full circle is effected down to pocket depth to remove the residual material.

The base is milled from outside in a spiral movement.

The tool is retracted from the center of the pocket to a safety clearance.

- Edge finishing

In edge finishing, the edge is machined first with a helical movement down to the bottom.





A full circle is effected down to pocket depth to remove the residual material.





The tool is retracted from the edge and base of the pocket in a quadrant and retracted with rapid traverse to a safety clearance.





Procedure



1. The part program or ShopMill program to be processed has been created and you are in the editor.
2. Press the "Milling" softkey.
3. Press the "Pocket" and "Circular pocket" softkeys. The "Circular Pocket" input window opens.

Parameters, G code program			Parameters, ShopMill program		
PL 	Machining plane		T	Tool name	
	Milling direction		D	Cutting edge number	
RP	Retraction plane	mm	F 	Feedrate	mm/min mm/tooth
SC	Safety clearance	mm	S / V 	Spindle speed or constant cutting rate	rpm m/min
F	Feedrate	*			

Parameter	Description	Unit
Machining 	<ul style="list-style-type: none"> ▽ (roughing, plane-by-plane or helical) ▽▽▽ (finishing, plane-by-plane or helical) ▽▽▽ edge (edge finishing, plane-by-plane or helical) Chamfering 	
Machining type 	<ul style="list-style-type: none"> Plane-by-plane Machine circular pocket plane-by-plane Helical Machine circular pocket using helical type 	
Machining position 	<ul style="list-style-type: none"> Single position A circular pocket is machined at the programmed position (X0, Y0, Z0). Position pattern Several circular pockets are machined in a position pattern (e.g. full circle, pitch circle, grid, etc.). 	
X0	The reference points refer to the center point of the circular pocket: Reference point X – (for single position only)	mm
Y0	Reference point Y – (for single position only)	mm
Z0	Reference point Z – (only for single position and G Code position pattern)	mm
∅	Diameter of pocket	mm
Z1 	Pocket depth (abs) or depth relative to Z0 (inc) – (only for ▽, ▽▽▽ and ▽▽▽ edge)	mm
DXY 	<ul style="list-style-type: none"> Maximum plane infeed Maximum plane infeed as a percentage of the milling cutter diameter - (only for ▽ and ▽▽▽) 	In %
DZ	Maximum depth infeed - (only for ▽, ▽▽▽ and ▽▽▽ Rand)	mm

Parameter	Description	Unit
UXY	Plane finishing allowance - (only for ▽, ▽▽▽ and ▽▽▽ edge)	mm
UZ	Depth finishing allowance – (only for ▽ and ▽▽▽)	mm
Insertion 	<p>Various insertion modes can be selected – (only for plane-by-plane machining method and for ▽, ▽▽▽ or ▽▽▽ edge):</p> <ul style="list-style-type: none"> • Predrilled (only for G code) • Perpendicular: Insert vertically at the center of pocket <p>The tool executes the calculated depth infeed vertically in the center of the pocket.</p> <p>Feedrate: Infeed rate as programmed under FZ</p> <ul style="list-style-type: none"> • Helical: Insert along helical path <p>The cutter center point traverses along the helical path determined by the radius and depth per revolution. If the depth for one infeed has been reached, a full circle motion is executed to eliminate the inclined insertion path.</p> <p>Feedrate: Machining feedrate</p> <p>Note: The vertical insertion into pocket center method can be used only if the tool can cut across center or if the workpiece has been predrilled.</p>	
FZ (only for G code)	Depth infeed rate – (only for insertion and vertical insertion)	*
FZ  (only for ShopMill)	Depth infeed rate – (only for insertion and vertical insertion)	mm/min mm/tooth
EP	Maximum pitch of helix - (for helical insertion only) The helix pitch may be lower due to the geometrical situation.	mm/rev
ER	Radius of helix - (only for helical insertion) The radius must not be larger than the milling cutter radius, otherwise material will remain. Also make sure the circular pocket is not violated	mm
Solid machining 	<ul style="list-style-type: none"> • Complete machining <p>The circular pocket must be milled from a solid workpiece (e.g. casting).</p> <ul style="list-style-type: none"> • Post machining <p>A small pocket or hole has already been machined in the workpiece. This needs to be enlarged. Parameters AZ, and Ø1 must be programmed.</p>	
FS	Chamfer width for chamfering - (for chamfering only)	mm
ZFS 	Insertion depth of tool tip (abs or inc) - (for chamfering only)	mm
AZ	Depth of premachining - (for remachining only)	mm
Ø1	Diameter of premachining - (for remachining only)	mm

* Unit of feedrate as programmed before the cycle call

8.2.4 Rectangular spigot (CYCLE76)

Function

You can mill various rectangular spigots with the "Rectangular spigot" cycle.

You can select from the following shapes with or without a corner radius:



Depending on the dimensions of the rectangular spigot in the workpiece drawing, you can select a corresponding reference point for the rectangular spigot.

In addition to the required rectangular spigot, you must also define a blank spigot, i.e. the outer limits of the material. The tool moves at rapid traverse outside this area. The blank spigot must not overlap adjacent blank spigots and is automatically placed by the cycle in a central position on the finished spigot.

The rectangular spigot is machined using only one infeed. If you want to machine the spigot using multiple infeeds, you must program the "Rectangular spigot" cycle several times with a reducing finishing allowance.

Sequence

1. The tool approaches the starting point at rapid traverse at the height of the retraction plane and is fed in to the safety clearance. The starting point is on the positive X axis rotated through α_0 .
2. The tool approaches the spigot contour sideways in a semicircle at machining feedrate. The tool first executes infeed at machining depth and then moves in the plane. The rectangular spigot is machined depending on the programmed machining direction (up-cut/down-cut) in a clockwise or counterclockwise direction.
3. When the rectangular spigot has been traversed once, the tool retracts from the contour in a semicircle and then infeed to the next machining depth is performed.
4. The rectangular spigot is approached again in a semicircle and traversed once. This process is repeated until the programmed spigot depth is reached.
5. The tool moves back to the safety clearance at rapid traverse.

Machining type











- **Roughing**
Roughing involves moving around the rectangular spigot until the programmed finishing allowance has been reached.
- **Finishing**
If you have programmed a finishing allowance, the rectangular spigot is moved around until depth Z1 is reached.
- **Chamfering**
Chamfering involves edge breaking at the upper edge of the rectangular spigot.

Procedure



1. The part program or ShopMill program to be processed has been created and you are in the editor.
2. Press the "Milling" softkey.
3. Press the "Multi-edge spigot" and "Rectangular spigot" softkeys. The "Rectangular Spigot" input window opens.

Parameters, G code program			Parameters, ShopMill program		
PL	Machining plane		T	Tool name	
	Milling direction		D	Cutting edge number	
RP	Retraction plane	mm	F	Feedrate	mm/min mm/tooth
SC	Safety clearance	mm	S / V	Spindle speed or constant cutting rate	rpm m/min
F	Feedrate	*			

Parameter	Description	Unit
FZ (only for G code)	Depth infeed rate	*
Reference point 	The following different reference point positions can be selected: <ul style="list-style-type: none">  (center)  (bottom left)  (bottom right)  (top left)  (top right) 	
Machining 	<ul style="list-style-type: none"> ∇ (roughing) ∇∇∇ (finishing) Chamfering 	
Machining position 	<ul style="list-style-type: none"> Single position A rectangular spigot is machined at the programmed position (X0, Y0, Z0). Position pattern Several rectangular spigots are machined in a position pattern (e.g. full circle, pitch circle, grid, etc.). 	
X0	The positions refer to the reference point: Reference point X – (for single position only)	mm
Y0	Reference point Y – (for single position only)	mm
Z0	Reference point Z – (only for single position and G Code position pattern)	mm
W	Width of spigot	mm
L	Length of spigot	mm
R	Corner radius	mm
α0	Angle of rotation	Degrees
Z1 	Spigot depth (abs) or depth relative to Z0 (inc) - (only for ∇ and ∇∇∇)	mm
DZ	Maximum depth infeed - (only for ∇ and ∇∇∇)	mm
UXY	Plane finishing allowance for the length (L) and width (W) of the rectangular spigot. Smaller rectangular spigot dimensions are obtained by calling the cycle again and programming it with a lower finishing allowance. - (only for ∇ and ∇∇∇)	mm
UZ	Depth finishing allowance (tool axis) - (only for ∇ and ∇∇∇)	mm
W1	Width of blank spigot (important for determining approach position) - (only for ∇ and ∇∇∇)	mm
L1	Length of blank spigot (important for determining approach position) - (only for ∇ and ∇∇∇)	mm
FS	Chamfer width for chamfering - (for chamfering only)	mm
ZFS 	Insertion depth of tool tip (abs or inc) - (for chamfering only)	mm

* Unit of feedrate as programmed before the cycle call

8.2.5 Circular spigot (CYCLE77)

Function

You can mill various circular spigots with the "Circular spigot" function.

In addition to the required circular spigot, you must also define a blank spigot, i.e. the outer limits of the material. The tool moves at rapid traverse outside this area. The blank spigot must not overlap adjacent blank spigots and is automatically placed on the finished spigot in a centered position.

The circular spigot is machined using only one infeed. If you want to machine the spigot using multiple infeeds, you must program the "Circular spigot" function several times with a reducing finishing allowance.

Input simple

For simple machining operations, you have the option to reduce the wide variety of parameters to the most important parameters using the "Input" selection field. In this "Input simple" mode, the hidden parameters are allocated a fixed value that cannot be adjusted.



Machine manufacturer

Various defined values can be pre-assigned using setting data.
Please refer to the machine manufacturer's specifications.

If the workpiece programming requires it, you can display and change all of the parameters using "Input complete"

Approach/retraction

1. The tool approaches the starting point at rapid traverse at the height of the retraction plane and is fed in to the safety clearance. The starting point is always on the positive X axis.
2. The tool approaches the spigot contour sideways in a semicircle at machining feedrate. The tool first executes infeed at machining depth and then moves in the plane. The circular spigot is machined depending on the programmed machining direction (up-cut/down-cut) in a clockwise or counterclockwise direction.
3. When the circular spigot has been traversed once, the tool retracts from the contour in a semicircle and then infeed to the next machining depth is performed.
4. The circular spigot is approached again in a semicircle and traversed once. This process is repeated until the programmed spigot depth is reached.
5. The tool moves back to the safety clearance at rapid traverse.

Machining type

You can select the machining mode for milling the circular spigot as follows:





- **Roughing**
Roughing involves moving round the circular spigot until the programmed finishing allowance has been reached.
- **Finishing**
If you have programmed a finishing allowance, the circular spigot is moved around until depth Z1 is reached.
- **Chamfering**
Chamfering involves edge breaking at the upper edge of the circular spigot.

Procedure



1. The part program or ShopMill program to be processed has been created and you are in the editor.
2. Press the "Milling" softkey.
3. Press the "Multi-edge spigot" and "Circular spigot" softkeys. The "Circular Spigot" input window opens.

Parameters, G code program			Parameters, ShopMill program		
PL	Machining plane		T	Tool name	
	Milling direction		D	Cutting edge number	
RP	Retraction plane	mm	F	Feedrate	mm/min mm/tooth
SC	Safety clearance	mm	S / V	Spindle speed or constant cutting rate	rpm m/min
F	Feedrate	*			

Parameter	Description	Unit
FZ (only for G code)	Depth infeed rate	*
Machining 	<ul style="list-style-type: none"> ▽ (roughing) ▽▽▽ (finishing) Chamfering 	
Machining position 	<ul style="list-style-type: none"> Single position A circular spigot is machined at the programmed position (X0, Y0, Z0). Position pattern Several circular spigots are machined in a position pattern (e.g. full circle, pitch circle, grid, etc.). 	
X0	The positions refer to the reference point: Reference point X – (for single position only)	mm
Y0	Reference point Y – (for single position only)	mm
Z0	Reference point Z – (only for single position and G Code position pattern)	mm
∅	Diameter of spigot	mm
Z1 	Spigot depth (abs) or depth relative to Z0 (inc) - (only for ▽ and ▽▽▽)	mm
DZ	Maximum depth infeed - (only for ▽ and ▽▽▽)	mm
UXY	Plane finishing allowance for the length (L) and width (W) of the circular spigot. Smaller circular spigot dimensions are obtained by calling the cycle again and programming it with a lower finishing allowance. - (only for ▽ and ▽▽▽)	mm
UZ	Depth finishing allowance (tool axis) - (only for ▽ and ▽▽▽)	mm
∅1	Diameter of blank spigot (important for determining approach position) - (only for ▽ and ▽▽▽)	mm
FS	Chamfer width for chamfering - (for chamfering only)	mm
ZFS 	Insertion depth of tool tip (abs or inc) - (for chamfering only)	mm

* Unit of feedrate as programmed before the cycle call

8.2.6 Multi-edge (CYCLE79)

Function

You can mill a multi-edge with any number of edges with the "Multi-edge" cycle.

You can select from the following shapes with or without a corner radius or chamfer:

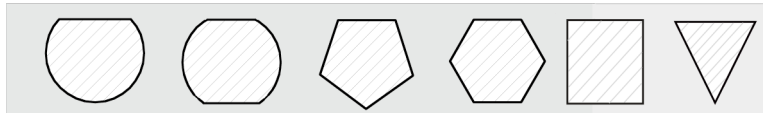

Approach/retraction

1. The tool approaches the starting point at rapid traverse at the height of the retraction plane and is fed in to the safety clearance.
2. The tool traverses the multi-edge in a quadrant at machining feedrate. The tool first executes infeed at machining depth and then moves in the plane. The multi-edge is machined depending on the programmed machining direction (up-cut/down-cut) in a clockwise or counterclockwise direction.
3. When the first plane has been machined, the tool retracts from the contour in a quadrant and then infeed to the next machining depth is performed.
4. The multi-edge is traversed again in a quadrant. This process is repeated until the depth of the multi-edge has been reached.
5. The tool retracts to the safety clearance at rapid traverse.

Note





A multi-edge with more than two edges is traversed helically; with a single or double edge, each edge is machined separately.







Procedure



1. The part program or ShopMill program to be processed has been created and you are in the editor.
2. Press the "Milling" softkey.
3. Press the "Multi-edge spigot" and "Multi-edge" softkeys. The "Multi-edge" input window opens.

8.2.6.1 Parameter

Parameters, G code program			Parameters, ShopMill program		
PL 	Machining plane		T	Tool name	
	Milling direction		D	Cutting edge number	
RP	Retraction plane	mm	F 	Feedrate	mm/min mm/tooth
SC	Safety clearance	mm	S / V 	Spindle speed or constant cutting rate	rpm m/min
F	Feedrate	*			

Parameter	Description	Unit
FZ (only for G code)	Depth infeed rate	*
Machining 	<ul style="list-style-type: none"> ∇ (roughing) ∇∇∇ (finishing) ∇∇∇ edge (edge finishing) Chamfering 	
Machining position 	<ul style="list-style-type: none"> Single position A polygon is milled at the programmed position (X0, Y0, Z0). Position pattern Several polygons are milled at the programmed position pattern (e.g. pitch circle, grid, line). 	
X0	The positions refer to the reference point: Reference point X – (for single position only)	mm
Y0	Reference point Y – (for single position only)	mm
Z0	Reference point Z – (only for single position and G Code position pattern)	mm
∅	Diameter of blank spigot	mm
N	Number of edges	
SW or L 	Width across flats or edge length	mm
α0	Angle of rotation	Degrees
R1 or FS1 	Rounding radius or chamfer width	mm
Z1 	Multi-edge depth (abs) or depth in relation to Z0 (inc) - (only for ∇, ∇∇∇ and ∇∇∇ edge)	mm
DXY 	<ul style="list-style-type: none"> Maximum plane infeed Maximum plane infeed as a percentage of the milling cutter diameter - (only for ∇ and ∇∇∇) 	mm %
DZ	Maximum depth infeed - (only for ∇ and ∇∇∇)	mm

Parameter	Description	Unit
UXY	Plane finishing allowance - (only for ∇ , $\nabla\nabla$ and $\nabla\nabla\nabla$ edge)	mm
UZ	Depth finishing allowance – (only for ∇ and $\nabla\nabla$)	mm
FS	Chamfer width for chamfering - (for chamfering only)	mm
ZFS 	Insertion depth of tool tip (abs or inc) - (for chamfering only)	mm %

* Unit of feedrate as programmed before the cycle call

8.2.7 Longitudinal groove (SLOT1)

Function

You can mill any longitudinal slot with the "longitudinal slot" milling function.

The following machining methods are available:

- Mill circular pocket from solid material.

Depending on the dimensions of the longitudinal slot in the workpiece drawing, you can select a corresponding reference point for the longitudinal slot.

- Predrill longitudinal slot first if, for example, the milling cutter does not cut in the center (e.g. for ShopMill, program the drilling, rectangular pocket and position program blocks in succession).

In this case, select the predrilling position corresponding to the "Vertical" parameter under "Insertion".

Approach/retraction

1. The tool moves at rapid traverse to the retraction plane and infeeds at safety clearance.
2. The tool is inserted into the material according to the chosen strategy.
3. The longitudinal slot is always machined with the chosen machining type from inside out.
4. The tool moves back to the safety clearance at rapid traverse.

Machining type

You can select the machining mode for milling the longitudinal slot as follows:

- **Roughing**

During roughing, the individual planes of the slot are machined one after the other until depth Z1 is reached.

- **Finishing**

During finishing, the edge is always machined first. The slot edge is approached on the quadrant that joins the corner radius. In the last infeed, the base is finished from the center out.

- **Edge finishing**

Edge finishing is performed in the same way as finishing, except that the last infeed (finish base) is omitted.

- **Chamfering**

Chamfering involves edge breaking at the upper edge of the longitudinal slot.

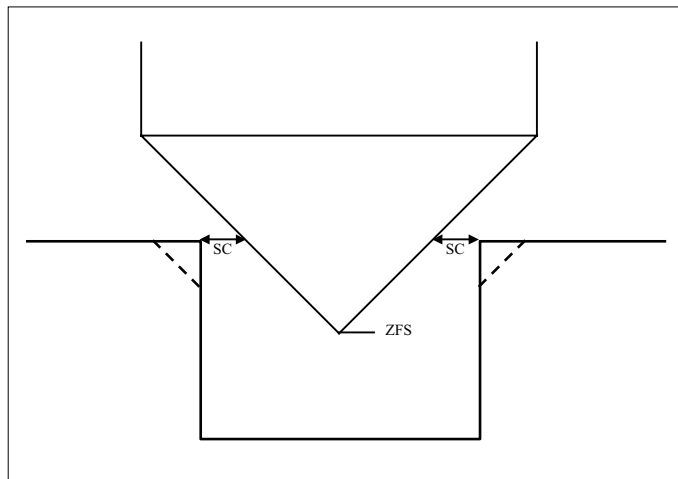

Figure 8-3 Geometries when chamfering inside contours

Note

The following error messages can occur when chamfering inside contours:

- **Safety clearance in the program header too large**

This error message appears when chamfering would, in principle, be possible with the parameters entered for FS and ZFS, but the safety clearance then could not be maintained.

- **Immersion depth too large**

This error message appears when chamfering would be possible through the reduction of the immersion depth ZFS.

- **Tool diameter too large**









This error message appears when the tool would already damage the edges during insertion. In this case, the chamfer FS must be reduced.



Procedure

1. The part program or ShopMill program to be processed has been created and you are in the editor.
2. Press the "Milling" softkey.
3. Press the "Groove" and "Longitudinal groove" softkeys.
The "Longitudinal Groove (SLOT1)" input window opens.



Parameters, G code program			Parameters, ShopMill program		
PL 	Machining plane		T	Tool name	
	Milling direction		D	Cutting edge number	
RP	Retraction plane	mm	F 	Feedrate	mm/min mm/tooth
SC	Safety clearance	mm	S / V 	Spindle speed or constant cutting rate	rpm m/min
F	Feedrate	*			

Parameter	Description	Unit
Reference point 	Position of the reference point: <ul style="list-style-type: none"> (lefthand edge)  (inside left)  (center)  (inside right)  (righthand edge)  	
Machining 	<ul style="list-style-type: none"> ∇ (roughing) ∇∇∇ (finishing) ∇∇∇ edge (edge finishing) Chamfering 	
Machining position 	<ul style="list-style-type: none"> Single position A slot is milled at the programmed position (X0, Y0, Z0). Position pattern Several slots are milled at the programmed position pattern (e.g. pitch circle, grid, line). 	
X0	The positions refer to the reference point: Reference point X – (for single position only)	mm
Y0	Reference point Y – (for single position only)	mm
Z0	Reference point Z – (only for single position and G Code position pattern)	mm
W	Slot width	mm
L	Slot length	mm
α0	Angle of rotation	Degrees
Z1 	Slot depth (abs) or depth relative to Z0 (inc) – (only for ∇, ∇∇∇ and ∇∇∇ edge)	mm
DXY (only ShopMill)	<ul style="list-style-type: none"> Maximum plane infeed Maximum plane infeed as a percentage of the milling cutter diameter - (only for ∇ and ∇∇∇) 	mm %
DZ	Maximum depth infeed - (only for ∇, ∇∇∇ and ∇∇∇ Rand)	mm
UXY	Plane finishing allowance - (only for ∇, ∇∇∇ and ∇∇∇ edge)	mm
UZ	Depth finishing allowance (slot base) - (only for ∇ and ∇∇∇)	mm

Parameter	Description	Unit
Insertion 	<p>The following insertion modes can be selected:</p> <ul style="list-style-type: none"> • Predrilled: (only for G code) Approach reference point shifted by the amount of the safety clearance with G0. • Perpendicular: Depending on the effective milling tool width (milling tool diameter x DXY[%]) or DXY [mm] – at the pocket center or at the pocket edge, is moved to the infeed depth. ShopMill: <ul style="list-style-type: none"> – At the edge of the longitudinal slot ("inside left"): Effective milling tool width >= half the slot width. – At the longitudinal slot center: Effective milling tool width < half the slot width. • G code: The tool is inserted to the infeed depth at the reference point "inside left". Note: This setting can be used only if the cutter can cut across center. • Helical: Insertion on helical path (only for G code) The cutter center point traverses along the helical path determined by the radius and depth per revolution (helical path). If the depth for one infeed has been reached, a full longitudinal slot is machined to eliminate the inclined insertion path. • Oscillating: Insert with oscillation along center axis of longitudinal slot The cutter center point oscillates along a linear path until it reaches the depth infeed. When the depth has been reached, the path is traversed again without depth infeed in order to remove the slope caused by insertion. 	mm
FZ (only for G code)	Depth infeed rate – (for vertical insertion only)	*
FZ  (only for ShopMill)	Depth infeed rate – (for vertical insertion only)	mm/min mm/tooth
EP (only for G code)	Maximum pitch of helix – (for helical insertion only)	mm/rev
ER (only for G code)	Radius of helix – (for helical insertion only) The radius cannot be any larger than the cutter radius; otherwise, material will remain.	mm
EW	Maximum insertion angle - (for insertion with oscillation only)	Degrees
FS	Chamfer width for chamfering (inc) - (for chamfering only),	mm
ZFS 	Insertion depth of tool tip (abs or inc) - (for chamfering only)	mm

* Unit of feedrate as programmed before the cycle call

8.2.8 Circumferential groove (SLOT2)

Function

You can mill one or several circumferential slots of equal size on a full or pitch circle with the "circumferential slot" cycle.

Tool size

Please note that there is a minimum size for the milling cutter used to machine the circumferential slot:

- Roughing:
1/2 groove width W – finishing allowance $UXY \leq$ milling cutter diameter
- Finishing:
1/2 groove width $W \leq$ milling cutter diameter
- Edge finishing:
Finishing allowance $UXY \leq$ milling cutter diameter

Annular groove

To create an annular groove, you must enter the following values for the "Number N" and "Aperture angle α_1 " parameters:

$$N = 1$$

$$\alpha_1 = 360^\circ$$

Approach/retraction

1. The tool approaches the center point of the semicircle at the end of the slot at rapid traverse at the height of the retraction plane and adjusts to the safety clearance.
2. Then, the tool enters the workpiece at machining infeed (taking into consideration the maximum infeed in the Z direction and the finishing allowance). The circumferential slot is machined in the programmed machining direction (up-cut or down-cut) in a clockwise or counterclockwise direction.
3. When the first circumferential slot is finished, the tool moves to the retraction plane at rapid traverse.
4. The next circumferential slot is approached along a straight line or circular path and then machined.
5. The tool moves back to the safety clearance at rapid traverse.

Machining type

You can select the machining mode for milling the circumferential groove as follows:

- **Roughing**

During roughing, the individual planes of the groove are machined one after the other from the center point of the semicircle at the end of the groove until depth Z1 is reached.

- **Finishing**

In "Finishing" mode, the edge is always machined first until depth Z1 is reached. The groove edge is approached on the quadrant that joins the radius. In the last infeed, the base is finished from the center point of the semicircle to the end of the groove.

- **Edge finishing**

Edge finishing is performed in the same way as finishing, except that the last infeed (finish base) is omitted.

- **Chamfering**

Chamfering involves edge breaking at the upper edge of the circumferential groove.

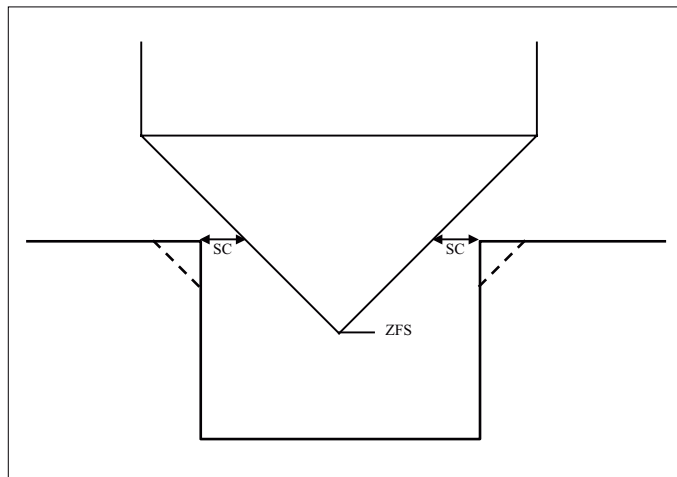

Figure 8-4 Geometries when chamfering inside contours

Note

The following error messages can occur when chamfering inside contours:

- **Safety clearance in the program header too large**
This error message appears when chamfering would, in principle, be possible with the parameters entered for FS and ZFS, but the safety clearance then could not be maintained.
- **Immersion depth too large**
This error message appears when chamfering would be possible through the reduction of the immersion depth ZFS.
- **Tool diameter too large**
This error message appears when the tool would already damage the edges during insertion. In this case, the chamfer FS must be reduced.



Procedure

1. The part program or ShopMill program to be processed has been created and you are in the editor.
2. Press the "Milling" softkey.
3. Press the "Groove" and "Circumferential groove" softkeys. The "Circumferential Groove" input window opens.



Parameters, G code program			Parameters, ShopMill program		
PL 	Machining plane		T	Tool name	
	Milling direction		D	Cutting edge number	
RP	Retraction plane	mm	F 	Feedrate	mm/min mm/tooth
SC	Safety clearance	mm	S / V 	Spindle speed or constant cutting rate	rpm m/min
F	Feedrate	*			

Parameter	Description	Unit
FZ (only for ShopMill)	Depth infeed rate (only for ▽ and ▽▽▽)	mm/min in/tooth
FZ (only for G code)	Depth infeed rate (only for ▽ and ▽▽▽)	*
Machining 	<ul style="list-style-type: none"> • ▽ (roughing) • ▽▽▽ (finishing) • ▽▽▽ edge (edge finishing) • Chamfering 	
Circular pattern 	<ul style="list-style-type: none"> • Full circle The circumferential slots are positioned around a full circle. The distance from one circumferential slot to the next circumferential slot is always the same and is calculated by the control. • Pitch circle The circumferential slots are positioned around a pitch circle. The distance from one circumferential slot to the next circumferential slot can be defined using angle α2. 	

Parameter	Description	Unit
X0	The positions refer to the center point: Reference point X	mm
Y0	Reference point Y	mm
Z0	Reference point Z	mm
N	Number of grooves	
R	Radius of circumferential slot	mm
α_0	Starting angle	Degrees
α_1	Opening angle of the slot	Degrees
α_2	Advance angle - (for pitch circle only)	Degrees
W	Slot width	mm
Z1 	Slot depth (abs) or depth relative to Z0 (inc) – (only for ∇ , $\nabla\nabla$ and $\nabla\nabla\nabla$ edge)	mm
DZ	Maximum depth infeed - (only for ∇ , $\nabla\nabla$ and $\nabla\nabla\nabla$ Rand)	mm
FS	Chamfer width for chamfering (inc) - (for chamfering only),	mm
ZFS 	Insertion depth of tool tip (abs or inc) - (for chamfering only),	mm
UXY	Plane finishing allowance - (only for ∇ , $\nabla\nabla$ and $\nabla\nabla\nabla$ edge)	mm
Positioning 	Positioning motion between the slots: <ul style="list-style-type: none"> • Straight line: Next position is approached linearly in rapid traverse. • Circular: Next position is approached along a circular path at the feedrate defined in the machine data. 	

* Unit of feedrate as programmed before the cycle call

8.2.9 Open groove (CYCLE899)

Function

Use the "Open slot" function if you want to machine open slots.

For roughing, you can choose between the following machining strategies, depending on your workpiece and machine properties.

- Vortex milling
- Plunge cutting

The following machining types are available to completely machine the slot:

- Roughing
- Rough-finishing
- Finishing
- Base finishing

- Edge finishing
- Chamfering

Vortex milling

Particularly where hardened materials are concerned, this process is used for roughing and contour machining using coated VHM milling cutters.

Vortex milling is the preferred technique for HSC roughing, as it ensures that the tool is never completely inserted. This means that the set overlap is precisely maintained.

Plunge cutting

Plunge cutting is the preferred method of machining slots for "unstable" machines and workpiece geometries. This method generally only exerts forces along the tool axis, i.e. perpendicular to the surface of the pocket/slot to be machined (with the XY plane in Z direction). Therefore, the tool is subject to virtually no deformation. As a result of the axial loading of the tool, there is hardly any danger of vibration occurring for unstable workpieces.

The cutting depth can be considerably increased. The plunge cutter, as it is known, ensures a longer service life due to less vibration for long overhangs.

Approach/retraction for vortex milling

1. The tool approaches the starting point in front of the slot in rapid traverse and maintains the safety clearance.
2. The tool goes to the cutting depth.
3. The open slot is always machined along its entire length using the selected machining method.
4. The tool retracts to the safety clearance in rapid traverse.

Approach/retraction for plunge cutting

1. The tool moves in rapid traverse to the starting point in front of the slot at the safety clearance.
2. The open slot is always machined along its entire length using the selected machining method.
3. The tool retracts to the safety clearance in rapid traverse.

Machining type, roughing vortex milling

Roughing is performed by moving the milling cutter along a circular path.

While performing this motion, the milling cutter is continuously fed into the plane. Once the milling cutter has traveled along the entire slot, it returns to its starting point, while continuing to move in a circular fashion. By doing this, it removes the next layer (infeed depth) in the Z direction. This process is repeated until the set slot depth plus the finishing allowance has been reached.

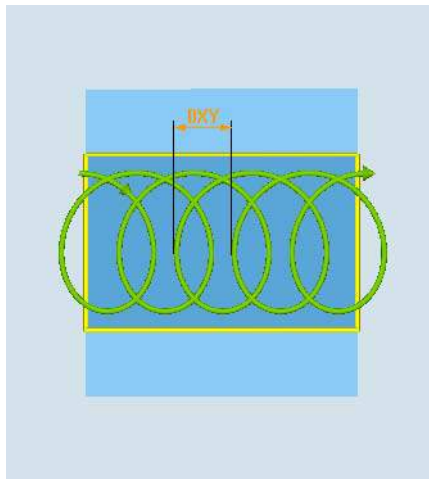

Vortex milling: Down-cut or up-cut

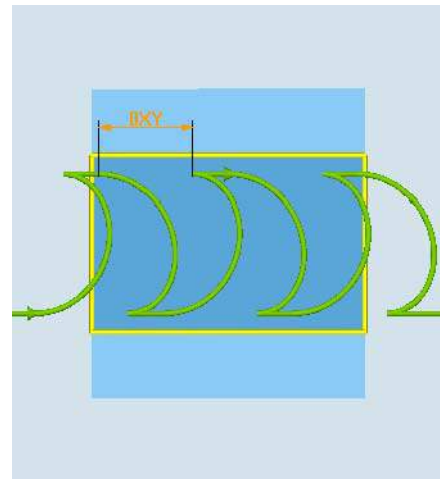

Vortex milling: Down-cut-up-cut

Supplementary conditions for vortex milling

- Roughing
1/2 slot width W – finishing allowance $UXY \leq$ milling cutter diameter
- Slot width
minimum $1.15 \times$ milling cutter diameter + finishing allowance
maximum, $2 \times$ milling cutter diameter + $2 \times$ finishing allowance
- Radial infeed
minimum, $0.02 \times$ milling cutter diameter
maximum, $0.25 \times$ milling cutter diameter

- Maximum infeed depth \leq cutting height of milling cutter

Please note that the cutting height of the milling cutter cannot be checked.

The maximum radial infeed depends on the milling cutter.

For hard materials, use a lower infeed.

Machining type, roughing plunge cutting

Roughing of the slot takes place sequentially along the length of the groove, with the milling cutter performing vertical insertions at the machining feedrate. The milling cutter is then retracted and repositioned at the next insertion point.

The milling cutter moves along the length of the slot, at half the infeed rate, and inserts alternately at the left-hand and right-hand walls.

The first insertion motion takes place at the slot edge, with the milling cutter inserted at half the infeed, less the safety clearance (if the safety clearance is greater than the infeed, this will be on the outside). For this cycle, the maximum width of the slot must be less than double the width of the milling cutter + the finishing allowance.

Following each insertion, the milling cutter is lifted by the height of the safety clearance at the machining feedrate. As far as possible, this occurs during what is known as the retraction process, i.e. if the milling cutter's wrap angle is less than 180° , it is lifted at an angle below 45° in the opposite direction to the bisector of the wrap area.

The milling cutter then traverses over the material in rapid traverse.

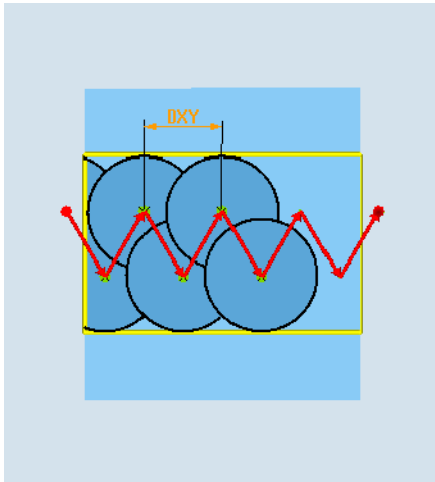

Supplementary conditions for plunge cutting

- Roughing
1/2 slot width W - finishing allowance $UXY \leq$ milling cutter diameter
- Maximum radial infeed
The maximum infeed depends on the cutting edge width of the milling cutter.
- Increment
The lateral increment is calculated on the basis of the required slot width, milling cutter diameter and finishing allowance.
- Retraction
Retraction involves the milling cutter being retracted at a 45° angle if the wrap angle is less than 180° . Otherwise, retraction is perpendicular, as is the case with drilling.

- Retraction

Retraction is performed perpendicular to the wrapped surface.

- Safety clearance

Traverse through the safety clearance beyond the end of the workpiece to prevent rounding of the slot walls at the ends.

Please note that the milling cutter's cutting edge cannot be checked for the maximum radial infeed.

Machining type, rough finishing

If there is too much residual material on the slot walls, unwanted corners are removed to the finishing dimension.

Machining type, finishing:

When finishing walls, the milling cutter travels along the slot walls, whereby just like for roughing, it is again fed in the Z direction, increment by increment. During this process, the milling cutter travels through the safety clearance beyond the beginning and end of the slot, so that an even slot wall surface can be guaranteed across the entire length of the slot.

Machining type, edge finishing

Edge finishing is performed in the same way as finishing, except that the last infeed (finish base) is omitted.

Machining type, finishing base:

When finishing the base, the milling cutter moves backwards and forwards once in the finished slot.

Machining type, chamfering

Chamfering involves breaking the edge at the upper slot edge.

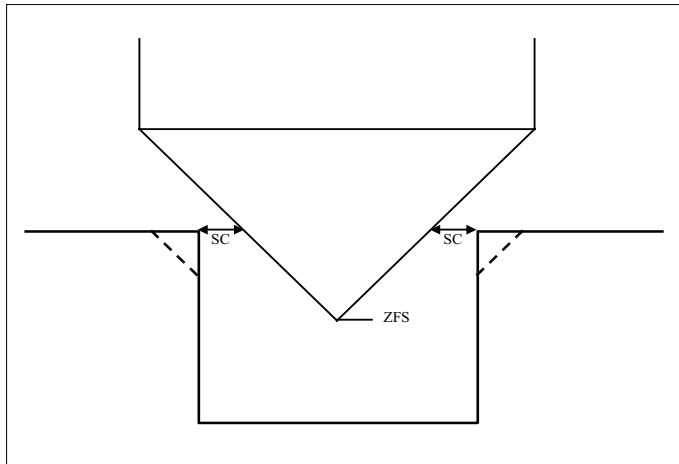

Figure 8-5 Geometries when chamfering inside contours

Note

The following error messages can occur when chamfering inside contours:

- **Safety clearance in the program header too large**
This error message appears when chamfering would, in principle, be possible with the parameters entered for FS and ZFS, but the safety clearance then could not be maintained.
 - **Immersion depth too large**
This error message appears when chamfering would be possible through the reduction of the immersion depth ZFS.
 - **Tool diameter too large**
This error message appears when the tool would already damage the edges during insertion. In this case, the chamfer FS must be reduced.
-

Additional supplementary conditions

- Finishing
 $1/2 \text{ slot width } W \leq \text{milling cutter diameter}$
- Edge finishing
Finishing allowance $UXY \leq \text{milling cutter diameter}$
- Chamfering
The tip angle must be entered into the tool table.

Procedure

1. The part program or ShopMill program to be processed has been created and you are in the editor.
2. Press the "Milling" softkey.
3. Press the "Slot" and "Open slot" softkeys.
The "Open slot" input window opens.



Parameters, G code program			Parameters, ShopMill program		
PL 	Machining plane		T	Tool name	
RP	Retraction plane	mm	D	Cutting edge number	
SC	Safety clearance	mm	F 	Feedrate	mm/min mm/tooth
F	Feedrate	*	S / V 	Spindle speed or constant cutting rate	rpm m/min

Parameter	Description	Unit
Reference point 	Position of the reference point: <ul style="list-style-type: none"> • (lefthand edge) • (center) • (righthand edge) 	
Machining 	<ul style="list-style-type: none"> • ▽ (roughing) • ▽▽ (pre-finishing) • ▽▽▽ (finishing) • ▽▽▽ base (base finishing) • ▽▽▽ edge (edge finishing) • Chamfering 	

8.2 Milling

Parameter	Description	Unit
Technology G	<ul style="list-style-type: none"> Vortex milling The milling cutter performs circular motions along the length of the slot and back again. Plunge cutting Sequential drilling motion along the tool axis. 	
G	Milling direction: - (except plunge cutting). <ul style="list-style-type: none"> Climbing cutting Conventional cutting Climbing-conventional cutting 	
Machining position G	<ul style="list-style-type: none"> Single position Mill a slot at the programmed position (X0, Y0, Z0). Position pattern Mill slots at a programmed position pattern (e.g. full circle or grid). 	
X0	The positions refer to the reference point: Reference point X – (for single position only)	mm
Y0	Reference point Y – (for single position only)	mm
Z0	Reference point Z – (only for single position and G Code position pattern)	mm
W	Slot width	mm
L	Slot length	mm
α0	Angle of rotation of slot	Degrees
Z1 G	Slot depth (abs) or depth relative to Z0 (abs) – (only for ▽, ▽▽▽, ▽▽▽ base and ▽▽▽ rough finishing)	mm
DXY G	<ul style="list-style-type: none"> Maximum plane infeed Maximum plane infeed as a percentage of the milling cutter diameter - (only for ▽)	mm %
DZ	Maximum depth infeed - (only for ▽, ▽▽▽ rough finishing, ▽▽▽ and ▽▽▽ edge) - (only for vortex milling)	mm
UXY	Plane finishing allowance (slot edge) - (only for ▽, ▽▽▽ rough finishing and ▽▽▽ base)	mm
UZ	Depth finishing allowance (slot base) - (only for ▽, ▽▽▽ rough finishing and ▽▽▽ edge)	mm
FS	Chamfer width for chamfering (inc) - (for chamfering only)	mm
ZFS	Insertion depth of tool tip (abs or inc) - (for chamfering only)	mm

* Unit of feedrate as programmed before the cycle call

8.2.10 Long hole (LONGHOLE) - only for G code programs

Function

In contrast to the groove, the width of the elongated hole is determined by the tool diameter.

Internally in the cycle, an optimum traversing path of the tool is determined, ruling out unnecessary idle passes. If several depth infeeds are required to machine an elongated hole, the infeed is carried out alternately at the end points. The path to be traversed in the plane along the longitudinal axis of the elongated hole changes its direction after each infeed. The cycle searches for the shortest path when changing to the next elongated hole.

Note

The cycle requires a milling cutter with a "face tooth cutting over center" (DIN 844).





Approach/retraction

1. Using G0, the starting position for the cycle is approached. In both axes of the current plane, the closest end point of the first elongated hole to be machined is approached at the level of the retraction plane in the tool axis and then lowered to the reference point shifted by the amount of the safety clearance.
2. Each elongated hole is milled in a reciprocating motion. The machining in the plane is performed using G1 and the programmed feedrate. At each reversal point, the infeed to the next machining depth calculated internally in the cycle is performed with G1 and the feedrate, until the final depth is reached.
3. Retraction to the retraction plane using G0 and approach to the next elongated hole on the shortest path.
4. After the last elongated hole has been machined, the tool at the position reached last in the machining plane is moved with G0 to the retraction plane, and the cycle terminated.

Procedure

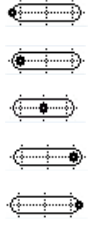

1. The part program or ShopMill program to be processed has been created and you are in the editor.
2. Press the "Milling" softkey.
3. Press the "Groove" and "Elongated hole" softkeys.
The "Elongated Hole" input window opens.

Parameter	Description	Unit
PL 	Machining plane	
RP	Retraction plane (abs)	
SC	Safety clearance (inc)	
F	Feedrate	*
Machining type 	<ul style="list-style-type: none"> • Plane-by-plane The tool is inserted to infeed depth in the pocket center. Note: This setting can be used only if the cutter can cut across center. • Oscillating Insert with oscillation along center axis of longitudinal slot: The cutter center point oscillates along a linear path until it reaches the depth infeed. When the depth has been reached, the path is traversed again without depth infeed in order to eliminate the inclined insertion path. 	mm
Reference point 	Position of the reference point: 	
Machining position 	<ul style="list-style-type: none"> • Single position An elongated hole is machined at the programmed position (X0, Y0, Z0). • Position pattern Several elongated holes are machined in the programmed position pattern (e.g. pitch circle, grid, line). 	
X0	The positions refer to the reference point: Reference point X – (for single position only)	mm
Y0	Reference point Y – (for single position only)	mm
Z0	Reference point Z	mm
L	Elongated hole length	mm
$\alpha 0$	Angle of rotation	Degrees
Z1 	Elongated hole depth (abs) or depth in relation to Z0 (inc)	mm
DZ	Maximum depth infeed	mm
FZ	Depth infeed rate	*

* Unit of feedrate as programmed before the cycle call

8.2.11 Thread milling (CYCLE70)

Function

Using a thread cutter, internal or external threads can be machined with the same pitch. Threads can be machined as right-hand or left-hand threads and from top to bottom or vice versa.

For metric threads (thread pitch P in mm/rev), the cycle assigns a value (calculated on the basis of the thread pitch) to the thread depth H1 parameter. You can change this value. The default selection must be activated via a machine data code.



Machine manufacturer

Please refer to the machine manufacturer's specifications.

The entered feedrate acts on the workpiece contour, i.e. it refers to the thread diameter. However the feedrate of the cutter center point is displayed. That is why a smaller value is displayed for internal threads and a larger value is displayed for external threads than was entered.

Approach/retraction when milling internal threads

1. Positioning on retraction plane with rapid traverse.
2. Approach of starting point of the approach circle in the current plane with rapid traverse.
3. Infeed to a starting point in the tool axis calculated internally in the controller with rapid traverse.
4. Approach motion to thread diameter on an approach circle calculated internally in the controller with the programmed feedrate, taking into account the finishing allowance and maximum plane infeed.
5. Thread cutting along a spiral path in clockwise or counter-clockwise direction (depending on whether it is left-hand/right-hand thread, for number of cutting teeth of a milling plate (NT) ≥ 2 only one rotation, offset in the Z direction).
To reach the programmed thread length, traversing is beyond the Z1 value for different distances depending on the thread parameters.
6. Exit motion along a circular path in the same rotational direction at programmed feedrate.
7. With a programmed number of threads per cutting edge $NT > 2$, the tool is fed in (offset) by the amount $NT-1$ in the Z direction. Points 4 to 7 are repeated until the programmed thread depth is reached.
8. If the plane infeed is less than the thread depth, points 3 to 7 are repeated until the thread depth + programmed allowance is reached.
9. Retract on the thread center point and then to retraction plane in the tool axis in rapid traverse.



Please note that when milling an internal thread the tool must not exceed the following value:



$$\text{Milling cutter diameter} < (\text{nominal diameter} - 2 \cdot \text{thread depth H1})$$





Approach/retraction when milling external threads

1. Positioning on retraction plane with rapid traverse.
2. Approach of starting point of the approach circle in the current plane with rapid traverse.
3. Infeed to a starting point in the tool axis calculated internally in the controller with rapid traverse.
4. Approach motion to thread core diameter on an approach circle calculated internally in the controller with the programmed feedrate, taking into account the finishing allowance and maximum plane infeed.
5. Cut thread along a spiral path in clockwise or counter-clockwise direction (depending on whether it is left-hand/right-hand thread, with $NT \geq 2$ only one rotation, offset in Z direction).
To reach the programmed thread length, traversing is beyond the Z1 value for different distances depending on the thread parameters.
6. Exit motion along a circular path in opposite rotational direction at programmed feedrate.
7. With a programmed number of threads per cutting edge $NT > 2$, the tool is fed in (offset) by the amount $NT-1$ in the Z direction. Points 4 to 7 are repeated until the programmed thread depth is reached.
8. If the plane infeed is less than the thread depth, points 3 to 7 are repeated until the thread depth + programmed allowance is reached.
9. Retraction on the retraction plane in the tool axis with rapid traverse.





Procedure

1. The part program or ShopMill program to be processed has been created and you are in the editor.
2. Press the "Milling" softkey.

3. Press the "Thread milling" softkey.
The "thread milling" input window opens.

Parameters, G code program			Parameters, ShopMill program		
PL 	Machining plane		T	Tool name	
RP	Retraction plane	mm	D	Cutting edge number	
SC	Safety clearance	mm	F 	Feedrate	mm/min mm/tooth
F	Feedrate	*	S / V 	Spindle speed or constant cutting rate	rpm m/min

Parameter	Description	Unit
Machining	<ul style="list-style-type: none"> ∇ (roughing) ∇∇∇ (finishing) 	
	Machining direction: <ul style="list-style-type: none"> Z0 → Z1 Machining from top to bottom Z1 → Z0 Machining from bottom to top 	
	Direction of rotation of the thread: <ul style="list-style-type: none"> Right-hand thread A right-hand thread is cut. Left-hand thread A left-hand thread is cut. 	
	Position of the thread: <ul style="list-style-type: none"> Internal thread An internal thread is cut. External thread An external thread is cut. 	
NT	Number of teeth per cutting edge Single or multiple toothed milling inserts can be used. The motions required are executed by the cycle internally, so that the tip of the bottom tooth on the milling insert corresponds to the programmed end position when the thread end position is reached. Depending on the cutting edge geometry of the milling insert, the retraction path must be taken into account at the base of the workpiece.	
 (only for G code)	Machining position: <ul style="list-style-type: none"> Single position Position pattern (MCALL) 	

8.2 Milling

Parameter	Description	Unit
 X0 Y0 Z0 (only for G code)	The positions refer to the center point: Reference point X – (for single position only) Reference point Y – (for single position only) Reference point Z	mm mm mm
Z1 	End point of the thread (abs) or thread length (inc)	mm
Table	Thread table selection: <ul style="list-style-type: none"> • Without • ISO metric • Whitworth BSW • Whitworth BSP • UNC 	
Selection – (not for table "without") 	Selection of table value: e.g. <ul style="list-style-type: none"> • M3; M10; etc. (ISO metric) • W3/4"; etc. (Whitworth BSW) • G3/4"; etc. (Whitworth BSP) • N1" - 8 UNC; etc. (UNC) 	
P	Display of the thread pitch for the parameter input in the input field "Table" and "Selection".	MODULUS Turns/" mm/rev inch/rev
P  - (selection option only for table selection "without")	Pitch ... <ul style="list-style-type: none"> • in MODULUS: For instance, used for worms that mesh with a gearwheel. • per inch: Used with pipe threads, for example. When entered per inch, enter the integer number in front of the decimal point in the first parameter field and the figures after the decimal point as a fraction in the second and third field. <ul style="list-style-type: none"> • in mm/rev • in inch/rev The tool used depends on the thread pitch.	MODUL Turns/" mm/rev in/rev
∅	Nominal diameter Example: Nominal diameter of M12 = 12 mm	mm
H1	Thread depth	mm
αS	Starting angle	Degrees
rev	Finishing allowance in X and Y - (only for ∇)	mm

* Unit of feedrate as programmed before the cycle call

8.2.12 Engraving (CYCLE60)

Function

The "Engraving" function is used to engrave a text on a workpiece along a line or arc.

You can enter the text directly in the text field as "fixed text" or assign it via a variable as "variable text".

Engraving uses a proportional font, i.e., the individual characters are of different widths.

Approach/retraction

1. The tool approaches the starting point at rapid traverse at the height of the retraction plane and adjusts to the safety clearance.
2. The tool moves to the machining depth FZ at the infeed feedrate Z1 and mills the characters.
3. The tool retracts to the safety clearance at rapid traverse and moves along a straight line to the next character.
4. Steps 2 and 3 are repeated until the entire text has been milled.
5. The tool moves to the retraction plane in rapid traverse.

Procedure



1. The part program or ShopMill program to be processed has been created and you are in the editor.
2. Press the "Milling" softkey.
3. Press the "Engraving" softkey.
The "Engraving" input window opens.

Entering the engraving text

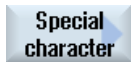

4. Press the "Special characters" softkey if you need a character that does not appear on the input keys.

The "Special characters" window appears.

- Position the cursor on the desired character.
- Press the "OK" softkey.

The selected character is inserted into the text at the cursor position.



5. If you wish to delete the complete text, press the "Delete text" and "Delete" softkeys one after the other.



6. Press the "Lowercase" softkey to enter lowercase letters. Press it again to enter uppercase letters.



7. Press the "Variable" and "Date" softkeys if you want to engrave the current date.

The data is inserted in the European date format (<DD>.<MM>.<YYYY>).

To obtain a different date format, you must adapt the format specified in the text field. For example, to engrave the date in the American date format (month/day/year => 8/16/04), change the format to <M>/<D>/<YY> .



7. Press the "Variable" and "Time" softkeys if you want to engrave the current time.

The time is inserted in the European format (<TIME24>).

To have the time in the American format, change the format to <TIME12>.

Example:

Text entry: Time: <TIME24> Execute: Time: 16.35

Time: <TIME12> Execute: Time: 04.35 PM



7. • Press the "Variable" and "Workpiece count 000123" softkeys to engrave a workpiece count with a fixed number of digits and leading zeroes.

The format text <#####,\$AC_ACTUAL_PARTS> is inserted and you return to the engraving field with the softkey bar.

- Define the number of digits by adjusting the number of place holders (#) in the engraving field.

If the specified number of positions (e.g. ##) is not sufficient to represent the unit quantity, then the cycle automatically increases the number of positions.

- OR



7. • Press the "Variable" and "Workpiece count 123" softkeys if you want to engrave a workpiece count without lead zeroes.

The format text <#,_\$AC_ACTUAL_PARTS> is inserted and you return to the engraving field with the softkey bar.

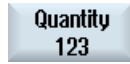

- Define the number of digits by adjusting the number of place holders in the engraving field.

If the specified number of digits is not enough to display the workpiece count (e.g. 123), the cycle will automatically increase the number digits.



7. • Press the "Variable" and "Number 123.456" softkeys if you want to engrave a number in a certain format.

The format text <#.###,_VAR_NUM> is inserted and you return to the engraving field with the softkey bar.

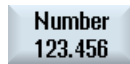

- The place holders #.### define the digit format in which the number defined in _VAR_NUM will be engraved.

For example, if you have stored 12.35 in _VAR_NUM, you can format the variable as follows.

Entry	Release	Meaning
<#,_VAR_NUM>	12	Places before decimal point unformatted, no places after the decimal point
<####,_VAR_NUM>	0012	4 places before decimal point, leading zeros, no places after the decimal point
< #,_VAR_NUM>	12	4 places before decimal point, leading blanks, no places after the decimal point
<#.,_VAR_NUM>	12.35	Integer and fractional digits not formatted.
<#.#,_VAR_NUM>	12.4	Places before decimal point unformatted, 1 place after the decimal point (rounded)
<#.##_VAR_NUM>	12.35	Places before decimal point unformatted, 2 places after the decimal point (rounded)
<#.####,_VAR_NUM>	12.3500	Places before decimal point unformatted, 4 places after the decimal point (rounded)

If there is insufficient space in front of the decimal point to display the number entered, it is automatically extended. If the specified number of digits is larger than the number to be engraved, the output format is automatically filled with the appropriate number of leading and trailing zeroes.

Instead of the decimal point you can also use a blank.

Instead of `_VAR_NUM` you can use any other numerical variable (e.g. `R0`).



7. Press the "Variable" and "Variable text" softkeys if you want to take the text to be engraved (up to 200 characters) from a variable.



The format text `<Text, _VAR_TEXT>` is inserted and you return to the engraving field with the softkey bar.

You can use any other text variable instead of `_VAR_TEXT`.

Note

Entering the engraving text

Only single-line entries without line break are permissible!

Variable texts

There are various ways of defining variable text:

- Date and time

For example, you can engrave the time and date of manufacture on a workpiece. The values for date and time are read from the NCK.

- Quantity

Using the workpiece variables you can assign a consecutive number to the workpieces.

You can define the format (number of digits, leading zeroes).

The place holder (`#`) is used to format the number of digits at which the workpiece counts output will begin.

If you do not want to output a count of 1 for the first workpiece, you can specify an additive value (e.g., `<#,$AC_ACTUAL_PARTS + 100>`). The workpiece count output is then incremented by this value (e. g. 101, 102, 103,...).

- Numbers

When outputting number (e. g. measurement results), you can select the output format (digits either side of the point) of the number to be engraved.

- Text



Instead of entering a fixed text in the engraving text field, you can specify the text to be engraved via a text variable (e. g., `_VAR_TEXT="ABC123"`).





Mirror writing







You can engrave the text mirrored on the workpiece.

Full circle

If you want to distribute the characters evenly around a full circle, enter the arc angle $\alpha=360^\circ$. The cycle then distributes the characters evenly around the full circle.

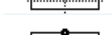
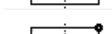
Parameters, G code program			Parameters, ShopMill program		
PL 	Machining plane		T	Tool name	
RP	Retraction plane	mm	D	Cutting edge number	
SC	Safety clearance	mm	F 	Feedrate	mm/min mm/tooth
F	Feedrate	*	S / V 	Spindle speed or constant cutting rate	rpm m/min

Parameter	Description	Unit
FZ (only for G code)	Depth infeed rate	*
FZ  (only for ShopMill)	Depth infeed rate	mm/min mm/tooth
Alignment 	<ul style="list-style-type: none"> •  (linear alignment) •  (curved alignment) •  (curved alignment) 	

Parameter	Description	Unit
Reference point U	Position of the reference point <ul style="list-style-type: none">  bottom left  bottom center  bottom right  top left  top center  top right  left-hand edge  center  right-hand edge 	
Mirror writing	<ul style="list-style-type: none"> Yes The mirrored text is engraved on the workpiece. No The text is engraved on the workpiece without mirroring. 	
Engraving text	maximum 100 characters	
X0 or R U	Reference point X (abs) or reference point length polar – (in ShopMill for curved alignment only)	mm
Y0 or α0 U	Reference point Y (abs) or reference point angle polar – (in ShopMill for curved alignment only)	mm or degrees
X0	Reference point Y (abs) (for linear alignment only)	mm
Y0	Reference point Y (abs) (for linear alignment only)	mm
Z0	Reference point Z (abs)	mm
Z1 U	Engraving depth (abs) or depth referred to Z0 (inc)	mm
W	Character height	mm
DX1 or α2 U	Distance between characters or angle of opening – (for curved alignment only)	mm or degrees
DX1 or DX2 U	Distance between characters or total width – (for linear alignment only)	mm
α1	Text direction (for linear alignment only)	Degrees
XM or LM U (only for G code)	Center point X (abs) or center point length polar – (for curved alignment only)	mm
YM or αM U (only for G code)	Center point Y (abs) or center point angle polar – (for curved alignment only)	mm or degrees
XM (ShopMill only)	Center point X (abs) – (only for curved alignment)	mm
YM (ShopMill only)	Center point Y (abs) – (only for curved alignment)	mm

* Unit of feedrate as programmed before the cycle call

8.3 Contour milling

8.3.1 General

Function

You can mill simple or complex contours with the "Contour milling" cycle. You can define open contours or closed contours (pockets, islands, spigots).

A contour comprises separate contour elements, whereby at least two and up to 250 elements result in a defined contour. Radii, chamfers and tangential transitions are available as contour transition elements.

The integrated contour calculator calculates the intersection points of the individual contour elements taking into account the geometrical relationships, which allows you to enter incompletely dimensioned elements.

With contour milling, you must always program the geometry of the contour before you program the technology.

8.3.2 Representation of the contour

G Code program

In the editor, the contour is represented in a program section using individual program blocks. If you open an individual block, then the contour is opened.

ShopMill program





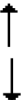

The cycle represents a contour as a program block in the program. If you open this block, the individual contour elements are listed symbolically and displayed in broken-line graphics.

Symbolic representation

The individual contour elements are represented by symbols adjacent to the graphics window. They appear in the order in which they were entered.

Contour element	Symbol	Meaning
Starting point		Starting point of the contour
Straight line up Straight line down		Straight line in 90° grid Straight line in 90° grid

8.3 Contour milling

Contour element	Symbol	Meaning
Straight line left Straight line right	 	Straight line in 90° grid Straight line in 90° grid
Straight line in any direction		Straight line with any gradient
Arc right Arc left	 	Circle Circle
Pole		Straight diagonal or circle in polar coordinates
Finish contour	END	End of contour definition

The different colors of the symbols indicate their status:

Foreground	Background	Meaning
Black	Blue	Cursor on new element
Black	Orange	Cursor on current element
Black	White	Normal element
Red	White	Element not currently evaluated (element will only be evaluated when it is selected with the cursor)

Graphical display

The progress of contour programming is shown in broken-line graphics while the contour elements are being entered.

When the contour element has been created, it can be displayed in different line styles and colors:

- Black: Programmed contour
- Orange: Current contour element
- Green dashed: Alternative element
- Blue dotted: Partially defined element

The scaling of the coordinate system is adjusted automatically to match the complete contour.

The position of the coordinate system is displayed in the graphics window.

8.3.3 Creating a new contour

Function

For each contour that you want to mill, you must create a new contour.

The contours are stored at the end of the program.

Note

When programming in the G code, it must be ensured that the contours are located after the end of program identifier!

The first step in creating a contour is to specify a starting point. Enter the contour element. The contour processor then automatically defines the end of the contour.

If you alter the tool axis, the cycle will automatically adjust the associated starting point axes. You can enter any additional commands (up to 40 characters) in G code format for the starting point.

Additional commands

You can program feedrates and M commands, for example, using additional G code commands. You can enter the additional commands (max. 40 characters) in the extended parameter screens ("All parameters" softkey). However, make sure that the additional commands do not collide with the generated G code of the contour. Therefore, do not use any G code commands of group 1 (G0, G1, G2, G3), no coordinates in the plane and no G code commands that have to be programmed in a separate block.

Procedure



1. The part program or ShopMill program to be processed has been created and you are in the editor.
2. Press the "Contour milling" and "New contour" softkeys.
The "New Contour" input window opens.
3. Enter a contour name.
4. Press the "Accept" softkey.
The input screen for the starting point of the contour appears. You can enter Cartesian or polar coordinates.

Cartesian starting point



1. Enter the starting point for the contour.
2. Enter any additional commands in G code format, as required.
3. Press the "Accept" softkey.
4. Enter the individual contour elements.

Polar starting point



1. Press the "Pole" softkey.
2. Enter the pole position in Cartesian coordinates.
3. Enter the starting point for the contour in polar coordinates.
4. Enter any additional commands in G code format, as required.
5. Press the "Accept" softkey.
6. Enter the individual contour elements.

Parameter	Description	Unit
PL	Machining plane	
X	Cartesian: Starting point X (abs)	mm
Y	Starting point Y (abs)	mm
X	Polar: Position pole (abs)	mm
Y	Position pole (abs)	Degrees
Starting point		
L1	Distance to pole, end point (abs)	mm
$\phi 1$	Polar angle to the pole, end point (abs)	Degrees
Additional commands	The contour is finished in continuous-path mode (G64). As a result, contour transitions such as corners, chamfers or radii may not be machined precisely. If you wish to avoid this, then it is possible to use additional commands when programming. Example: For a contour, first program the X parallel straight line and then enter "G9" (non-modal exact stop) for the additional command parameter. Then program the Y-parallel straight line. The corner will be machined exactly, as the feedrate at the end of the X-parallel straight line is briefly zero. Note: The additional commands are only effective for path milling!	

8.3.4 Creating contour elements

After you have created a new contour and specified the starting point, you can define the individual elements that make up the contour.

The following contour elements are available for the definition of a contour:

- Straight vertical line
- Straight horizontal line
- Diagonal line
- Circle/arc
- Pole

For each contour element, you must parameterize a separate parameter screen.

The coordinates for a horizontal or vertical line are entered in Cartesian format; however, for the contour elements Diagonal line and Circle/arc you can choose between Cartesian and polar coordinates. If you wish to enter polar coordinates you must first define a pole. If you have already defined a pole for the starting point, you can also refer the polar coordinates to this pole. Therefore, in this case, you do not have to define an additional pole.

Cylinder surface transformation

For contours (e.g. slots) on cylinders, lengths are frequently specified in the form of angles. If the "Cylinder surface transformation" function is activated, you can also define on a cylinder the length of contours (in the circumferential direction of the cylinder surface) using angles. This means instead of X, Y and I, J, you enter $X\alpha$, $Y\alpha$ and $I\alpha$, $J\alpha$.



Machine manufacturer

Please refer to the machine manufacturer's specifications.

Parameter input

Parameter entry is supported by various help screens that explain the parameters.

If you leave certain fields blank, the geometry processor assumes that the values are unknown and attempts to calculate them from other parameters.

Conflicts may result if you enter more parameters than are absolutely necessary for a contour. In such a case, try to enter fewer parameters and allow the geometry processor to calculate as many parameters as possible.

Contour transition elements

As a transition between two contour elements, you can choose a radius or a chamfer. The transition element is always attached at the end of a contour element. The contour transition element is selected in the parameter screen of the respective contour element.

You can use a contour transition element whenever there is an intersection between two successive elements which can be calculated from the input values. Otherwise you must use the straight/circle contour elements.

The contour end is an exception. Although there is no intersection to another element, you can still define a radius or a chamfer as a transition element for the blank.

Additional functions

The following additional functions are available for programming a contour:

- Tangent to preceding element

You can program the transition to the preceding element as tangent.

- Dialog box selection

If two different possible contours result from the parameters entered thus far, one of the options must be selected.

- Close contour

From the actual position, you can close the contour with a straight line to the starting point.

Procedure for entering contour elements

1. The part program or the machining schedule is opened. Position the cursor at the desired entry position.

2. Contour input using contour support:



- 2.1 Press the "Contour milling", "Contour" and "New contour" softkeys.



- 2.2 In the opened input window, enter a name for the contour, e.g. contour_1.

Press the "Accept" softkey.



- 2.3 The input screen to enter the contour opens, in which you initially enter a starting point for the contour. This is marked in the lefthand navigation bar using the "+" symbol.

Press the "Accept" softkey.



3. Enter the individual contour elements of the machining direction.
Select a contour element via softkey.



The "Straight (e.g. X)" input window opens.

- OR

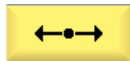

The "Straight (e.g. Y)" input window opens.

- OR



The "Straight (e.g. XY)" input window opens.

- OR



The "Circle" input window opens.

- OR



The "Pole Input" input window opens.



4. Enter all the data available from the workpiece drawing in the input screen (e.g. length of straight line, target position, transition to next element, angle of lead, etc.).



5. Press the "Accept" softkey.

The contour element is added to the contour.



6. When entering data for a contour element, you can program the transition to the preceding element as a tangent.

Press the "Tangent to prec. elem." softkey. The "tangential" selection appears in the parameter $\alpha 2$ entry field.

7. Repeat the procedure until the contour is complete.



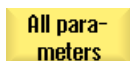

8. Press the "Accept" softkey.

The programmed contour is transferred into the process plan (program view).





9. If you want to display further parameters for certain contour elements, e.g. to enter additional commands, press the "All parameters" softkey.



Contour element "Straight line, e.g. X"

Parameter	Description	Unit
X 	End point X (abs or inc)	mm
$\alpha 1$	Starting angle e.g. to the X axis	Degrees
$\alpha 2$	Angle to the preceding element	Degrees
Transition to next element 	Type of transition <ul style="list-style-type: none"> • Radius • Chamfer 	
Radius	R Transition to following element - radius	mm
Chamfer	FS Transition to following element - chamfer	mm
Additional commands	Additional G code commands	









Contour element "straight line, e.g. Y"

Parameter	Description	Unit
Y 	End point Y (abs or inc)	mm
$\alpha 1$	Starting angle to X axis	Degrees
Transition to next element 	Type of transition <ul style="list-style-type: none"> • Radius • Chamfer 	
Radius	R Transition to following element - radius	mm
Chamfer	FS Transition to following element - chamfer	mm
Additional commands	Additional G code commands	

Contour element "Straight line, e.g. XY"

Parameter	Description	Unit
X 	End point X (abs or inc)	mm
Y 	End point Y (abs or inc)	mm
L	Length	mm
$\alpha 1$	Starting angle e.g. to the X axis	Degrees
$\alpha 2$	Angle to the preceding element	Degrees
Transition to next element 	Type of transition <ul style="list-style-type: none"> • Radius • Chamfer 	
Radius	R Transition to following element - radius	mm
Chamfer	FS Transition to following element - chamfer	mm
Additional commands	Additional G code commands	

Contour element "Circle"

Parameter	Description	Unit	
Direction of rotation 	 <ul style="list-style-type: none"> • Clockwise direction of rotation  <ul style="list-style-type: none"> • Counterclockwise direction of rotation 		
R	Radius	mm	
e.g. X 	End point X (abs or inc)	mm	
e.g. Y 	End point Y (abs or inc)	mm	
e.g. I 	Circle center point I (abs or inc)	mm	
e.g. J 	Circle center point J (abs or inc)	mm	
$\alpha 1$	Starting angle to X axis	Degrees	
$\alpha 2$	Angle to the preceding element	Degrees	
$\beta 1$	End angle to Z axis	Degrees	
$\beta 2$	Angle of opening	Degrees	
Transition to next element 	Type of transition <ul style="list-style-type: none"> • Radius • Chamfer 		
Radius	R	Transition to following element - radius	mm
Chamfer	FS	Transition to following element - chamfer	mm
Additional commands	Additional G code commands		

Contour element "Pole"

Parameter	Description	Unit
X	Position pole (abs)	mm
Y	Position pole (abs)	mm

Contour element "End"

The data for the transition at the contour end of the previous contour element is displayed in the "End" parameter screen.

The values cannot be edited.

8.3.5 Changing the contour

Function

You can change a previously created contour later.

If you want to create a contour that is similar to an existing contour, you can copy the existing one, rename it and just alter selected contour elements.

Individual contour elements can be

- added,
- changed,
- inserted or
- deleted.

Procedure for changing a contour element

1. Open the part program or ShopMill program to be executed.
2. With the cursor, select the program block where you want to change the contour. Open the geometry processor.
The individual contour elements are listed.
3. Position the cursor at the position where a contour element is to be inserted or changed.
4. Select the desired contour element with the cursor.
5. Enter the parameters in the input screen or delete the element and select a new element.



6. Press the "Accept" softkey.
The desired contour element is inserted in the contour or changed.

Procedure for deleting a contour element

1. Open the part program or ShopMill program to be executed.
2. Position the cursor on the contour element that you want to delete.
3. Press the "Delete element" softkey.

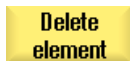

4. Press the "Delete" softkey.

8.3.6 Contour call (CYCLE62) - only for G code program

Function

The input creates a reference to the selected contour.

There are four ways to call the contour:

1. Contour name

The contour is in the calling main program.

2. Labels

The contour is in the calling main program and is limited by the labels that have been entered.

3. Subprogram

The contour is located in a subprogram in the same workpiece.

4. Labels in the subprogram

The contour is in a subprogram and is limited by the labels that have been entered.

Procedure



1. The subprogram to be edited has been created and you are in the editor.
2. Press the "Contour milling" softkey.
3. Press the "Contour" and "Contour call" softkeys. The "Contour Call" input window opens.
4. Assign parameters to the contour selection.

Parameter	Description	Unit
Contour selection 	<ul style="list-style-type: none"> • Contour name • Labels • Subprogram • Labels in the subprogram 	
Contour name	CON: Contour name	
Labels	<ul style="list-style-type: none"> • LAB1: Label 1 • LAB2: Label 2 	

Parameter	Description	Unit
Subprogram	PRG: Subprogram	
Labels in the subprogram	<ul style="list-style-type: none"> • PRG: Subprogram • LAB1: Label 1 • LAB2: Label 2 	

8.3.7 Path milling (CYCLE72)

Function

You can mill along any programmed contour with the "Path milling" cycle. The function operates with cutter radius compensation. Machining can be performed in either direction, i.e. in the direction of the programmed contour or in the opposite direction.

It is not imperative that the contour is closed. You can perform any of the following operations:

- Inside or outside machining (on left or right of the contour).
- Machining along center-point path.

For machining in the opposite direction, contours must not consist of more than 170 contour elements (incl. chamfers/radii). Special aspects (except for feed values) of free G code input are ignored during path milling in the opposite direction to the contour.

Programming of arbitrary contours

The machining of arbitrary open or closed contours is generally programmed as follows:

1. Enter contour

You build up the contour gradually from a series of different contour elements.

2. Contour call (CYCLE62)

You select the contour to be machined.

3. Path milling (roughing)

The contour is machined taking into account various approach and retract strategies.

4. Path milling (finishing)

If you programmed a finishing allowance for roughing, the contour is machined again.

5. Path milling (chamfering)

If you have planned edge breaking, chamfer the workpiece with a special tool.

Path milling on right or left of the contour

A programmed contour can be machined with the cutter radius compensation to the right or left. You can also select various modes and strategies of approach and retraction from the contour.

Approach/retraction mode

The tool can approach or retract from the contour along a quadrant, semi-circle or straight line.

- With a quadrant or semi-circle, you must specify the radius of the cutter center point path.
- With a straight line, you must specify the distance between the cutter outer edge and the contour starting or end point.

You can also program a mixture of modes, e.g. approach along quadrant, retract along semi-circle.

Approach/retraction strategy

You can choose between planar approach/retraction and spatial approach/retraction:

- Planar approach:
Approach is first at depth and then in the machining plane.
- Spatial approach:
Approach is at depth and in machining plane simultaneously.
- Retraction is performed in reverse order.
Mixed programming is possible, for example, approach in the machining plane, retract spatially.

Path milling along center-point path.



A programmed contour can also be machined along the center-point path if the radius correction was switched-out. In this case, approaching and retraction is only possible along a straight line or vertical. Vertical approach/retraction can be used for closed contours, for example.







Procedure









1. The part program or ShopMill program to be processed has been created and you are in the editor.
2. Press the "Contour milling" and "Path milling" softkeys.
The "Path Milling" input window opens.





8.3 Contour milling

Parameters, G code program			Parameters, ShopMill program		
PL 	Machining plane		T	Tool name	
RP	Retraction plane	mm	D	Cutting edge number	
SC	Safety clearance	mm	F 	Feedrate	mm/min mm/tooth
F	Feedrate	*	S / V 	Spindle speed or constant cutting rate	rpm m/min

Parameter	Description	Unit
Machining 	<ul style="list-style-type: none"> ▽ (roughing) ▽▽▽ (finishing) Chamfering 	
Machining direction 	<p>Machining in the programmed contour direction</p> <ul style="list-style-type: none"> Forward: Machining is performed in the programmed contour direction Backward: Machining is performed in the opposite direction to the programmed contour 	
Radius compensation 	<ul style="list-style-type: none"> Left (machining to the left of the contour)  Right (machining to the right of the contour)  off  <p>A programmed contour can also be machined on the center-point path. In this case, approaching and retraction is only possible along a straight line or vertical. Vertical approach/retraction can be used for closed contours, for example.</p>	
Z0	Reference point Z (abs or inc)	
Z1 	Final depth (abs) or final depth referred to Z0 (inc) - (only for ▽ and ▽▽▽)	mm
DZ	Maximum depth infeed - (only for ▽ and ▽▽▽)	mm
UZ	Depth finishing allowance - (only for ▽)	mm
FS	Chamfer width for chamfering (inc) - (for chamfering only)	mm
ZFS	Insertion depth of tool tip (abs or inc) - (for chamfering only)	mm
UXY	Finishing allowance, plane - (only for ▽ and G code, not for radius compensation off)	mm

Parameter	Description	Unit
Approach 	Planar approach mode: <ul style="list-style-type: none"> • Straight line: Slope in space • Quadrant: Part of a spiral (only with path milling left and right of the contour) • Semi-circle: Part of a spiral (only with path milling left and right of the contour) • Perpendicular: Perpendicular to the path (only with path milling on the center-point path) 	
Approach strategy 	<ul style="list-style-type: none"> • Axis by axis  • Spatial (only for "quadrant, semi-circle or straight line" approach)  	
R1	Approach radius - (only for "quadrant or semi-circle" approach)	mm
L1	Approach distance - (only for "straight line" approach)	mm
Retraction 	Planar retraction mode: <ul style="list-style-type: none"> • Straight line • Quadrant: Part of a spiral (only with path milling left and right of the contour) • Semi-circle: Part of a spiral (only with path milling left and right of the contour) 	
Retraction strategy 	<ul style="list-style-type: none"> • Axis by axis  • Spatial (not with perpendicular approach mode)  	
R2	Retraction radius - (only for "quadrant or semi-circle" retraction)	mm
L2	Retraction distance - (only for "straight line" retraction)	mm
Lift mode 	If more than one depth infeed is necessary, specify the retraction height to which the tool retracts between the individual infeeds (at the transition from the end of the contour to the start). Lift mode before new infeed <ul style="list-style-type: none"> • Z0 + safety clearance • By the safety clearance • to RP • No retraction 	

8.3 Contour milling

Parameter	Description	Unit
FZ  (only for ShopMill)	Depth infeed rate – (only for axis-by-axis approach strategy)	mm/min mm/tooth
FZ - (only for G code)	Depth infeed rate – (only for axis-by-axis approach strategy)	*
FS	Chamfer width for chamfering - (only for chamfering machining)	mm
ZFS 	Insertion depth of tool tip (abs or inc) - (for machining only)	mm

* Unit of feedrate as programmed before the cycle call

Note

Cylinder surface transformation with slot side compensation

For cylinder surface transformation with selected slot side compensation and approach/retraction in quadrant or semi-circle, the approach/retraction radius must be greater than “Offset to programmed path – tool radius”.

8.3.8 Contour pocket/contour spigot (CYCLE63/64)

Contours for pockets or islands

Contours for pockets or islands must be closed, i.e. the starting point and end point of the contour are identical. You can also mill pockets that contain one or more islands. The islands can also be located partially outside the pocket or overlap each other. The first contour you specify is interpreted as the pocket contour and all the others as islands.

Automatic calculation / manual input of the starting point

Using "Automatic starting point" you have the option of calculating the optimum plunge point.

By selecting "Manual starting point", you define the plunge point in the parameter screen.

If the islands and the miller diameter, which must be plunged at various locations, are obtained from the pocket contour, then the manual entry only defines the first plunge point; the remaining plunge points are automatically calculated.

Contours for spigots

Contours for spigots must be closed, i.e. the starting point and end point of the contour are identical. You can define multiple spigots that can also overlap. The first contour specified is interpreted as a blank contour and all others as spigots.

Machining

You program the machining of contour pockets with islands/blank contour with spigots, e.g. as follows:

1. Enter the pocket contour/blank contour
2. Enter the island/spigot contour
3. Call the contour for pocket contour/blank contour or island/spigot contour (only for G code program)
4. Center (this is only possible for pocket contour)
5. Predrill (this is only possible for pocket contour)
6. Solid machine/machine pocket / spigot - roughing
7. Solid machine/machine remaining material - roughing
8. Finishing (base/edge)
9. Chamfering

Note

The following error messages can occur when chamfering inside contours:

Safety clearance in the program header too large

This error message appears when chamfering would, in principle, be possible with the parameters entered for FS and ZFS, but the safety clearance then could not be maintained.

Immersion depth too large

This error message appears when chamfering would be possible through the reduction of the immersion depth ZFS.

Tool diameter too large

This error message appears when the tool would already damage the edges during insertion. In this case, the chamfer FS must be reduced.



Software option

For solid machining residual material, you require the option "residual material detection and machining".

Name convention

For multi-channel systems, cycles attach a "_C" and a two-digit number of the specific channel to the names of the programs to be generated, e.g. for channel 1 "_C01". This is the reason that the name of the main program must not end with "_C" and a two-digit number. This is monitored by the cycles.

For single-channel systems, cycles do not extend the name of the programs to be generated.

Note

G code programs

For G code programs, the programs to be generated, which do not include any path data, are saved in the directory in which the main program is located. In this case, it must be ensured that programs, which already exist in the directory and which have the same name as the programs to be generated, are overwritten.

8.3.9 Predrilling contour pocket (CYCLE64)

Role

In addition to predrilling, the cycle can be used for centering. The centering or predrilling program generated by the cycle is called for this purpose.

The number and positions of the required predrilled holes depends on the specific conditions, e.g. type of contour, tool, plane infeed, finishing allowances.

If you mill several pockets and want to avoid unnecessary tool changes, predrill all the pockets first and then remove the stock. In this case, for centering/predrilling, you also have to enter the parameters that appear when you press the "All parameters" softkey. These parameters must correspond to the parameters from the previous stock removal step.

Programming

When programming, proceed as follows:

1. Contour pocket 1
2. Centering
3. Contour pocket 2
4. Centering
5. Contour pocket 1
6. Predrilling
7. Contour pocket 2
8. Predrilling

- 9. Contour pocket 1
- 10. Stock removal
- 11. Contour pocket 2
- 12. Stock removal

If you are doing all the machining for the pocket at once, i.e. centering, rough-drilling and removing stock directly in sequence, and do not set the additional parameters for centering/rough-drilling, the cycle will take these parameter values from the stock removal (roughing) machining step. When programming in G code, these values must be specifically re-entered.

Procedure when centering



1. The part program or ShopMill program to be processed has been created and you are in the editor.
2. Press the "Cont. mill.", "Predrilling", and "Centering" softkeys.
The "Centering" input window opens.



Parameters, G code program			Parameters, ShopMill program		
PRG	Name of the program to be generated		T	Tool name	
PL	Machining plane		D	Cutting edge number	
Milling direction	<ul style="list-style-type: none"> • Synchronous operation • Up-cut operation 		F	Feedrate	mm/min mm/tooth
RP	Retraction plane	mm	S / V	Spindle speed or constant cutting rate	rpm m/min
SC	Safety clearance	mm			
F	Feedrate	mm/min			

Parameter	Description	Unit
TR	Reference tool Tool, which is used in the "Stock removal" machining step. This is used to determine the plunge position.	
Z0	Reference point Z	mm
Z1	Depth with reference to Z0 (inc.)	mm





8.3 Contour milling



Parameter	Description	Unit
DXY 	<ul style="list-style-type: none"> Maximum plane infeed Maximum plane infeed as a percentage of the milling cutter diameter 	mm %
UXY	Finishing allowance, plane	mm
Lift mode 	Lift mode before new infeed If the machining operation requires several points of insertion, the retraction height to which the tool is retracted, is selected as follows: <ul style="list-style-type: none"> To retraction plane Z0 + safety clearance If there are no elements larger than Z0 in the pocket area, "Z0 + safety clearance" can be selected as the lift mode.	mm mm

Predrilling procedure

- The part program or ShopMill program to be processed has been created and you are in the editor.
- Press the "Cont. mill.", "Predrilling", and "Predrilling" softkeys. The "Predrilling" input window opens.



Parameters, G code program			Parameters, ShopMill program		
PRG	Name of the program to be generated		T	Tool name	
PL 	Machining plane		D	Cutting edge number	
Milling direction 	<ul style="list-style-type: none"> Synchronous operation Up-cut operation 		F 	Feedrate	mm/min mm/tooth
RP	Retraction plane	mm	S / V 	Spindle speed or constant cutting rate	rpm m/min
SC	Safety clearance	mm			
F	Feedrate	mm/min			

Parameter	Description	Unit
TR	Reference tool Tool, which is used in the "Stock removal" machining step. This is used to determine the plunge position.	
Z0	Reference point in the tool axis Z	mm
Z1 	Pocket depth (abs) or depth referred to Z0 (inc)	mm
DXY 	<ul style="list-style-type: none"> Maximum plane infeed Maximum plane infeed as a percentage of the milling cutter diameter 	mm %
UXY	Finishing allowance, plane	mm
UZ	Finishing allowance, depth	mm
Lift mode 	Lift mode before new infeed If the machining operation requires several points of insertion, the retraction height to which the tool is retracted, is selected as follows: <ul style="list-style-type: none"> To retraction plane Z0 + safety clearance If there are no elements larger than Z0 in the pocket area, "Z0 + safety clearance" can be selected as the lift mode.	mm mm

8.3.10 Milling contour pocket (CYCLE63)

Function

Before you can machine a pocket with islands, you must enter the contour of the pocket and islands. The first contour you specify is interpreted as the pocket contour and all the others as islands.

From the programmed contours and the input screen form for stock removal, the cycle generates a program that removes the pockets with islands from inside to outside in parallel to the contour.





The islands can also be located partially outside the pocket or overlap each other.





Procedure





1. The part program or ShopMill program to be processed has been created and you are in the editor.
2. Press the "Contour milling" and "Pocket" softkeys.
The "Mill pocket" input window opens.



8.3 Contour milling

Parameters, G code program			Parameters, ShopMill program		
PRG	Name of the program to be generated		T	Tool name	
PL	Machining plane		D	Cutting edge number	
			F	Feedrate	mm/min mm/tooth
Milling direction 	<ul style="list-style-type: none"> Climbing cutting Conventional cutting 				
RP	Retraction plane	mm	S / V	Spindle speed or constant cutting rate	rpm m/min
					
SC	Safety clearance	mm			
F	Feedrate	mm/min			

Parameter	Description	Unit
Machining 	The following machining operations can be selected: <ul style="list-style-type: none"> ▽ (roughing) ▽▽▽ base (base finishing) ▽▽▽ edge (edge finishing) Chamfering 	
Z0	Reference point in the tool axis Z	mm
Z1 	Pocket depth (abs) or depth relative to Z0 (inc) - (only for ▽, ▽▽▽ base or ▽▽▽ edge)	mm
DXY 	<ul style="list-style-type: none"> Maximum plane infeed Maximum plane infeed as a percentage of the milling cutter diameter - (only for ▽ or ▽▽▽ base)	mm %
DZ	Maximum depth infeed – (only for ▽ or ▽▽▽ edge)	mm
UXY	Plane finishing allowance – (only for ▽, ▽▽▽ base or ▽▽▽ edge)	mm
UZ	Depth finishing allowance – (only for ▽ or ▽▽▽ base)	mm
Starting point 	<ul style="list-style-type: none"> Manual Starting point is manually entered Automatic Starting point is automatically calculated - (only for ▽ or ▽▽▽ base)	
XS	Starting point X - (only for "manual" starting point)	mm
YS	Starting point Y - (only for "manual" starting point)	mm

Parameter	Description	Unit
Insertion 	<p>The following insertion modes can be selected – (only for ∇, $\nabla\nabla\nabla$ base or $\nabla\nabla\nabla$ edge):</p> <ul style="list-style-type: none"> • Vertical insertion <p>The calculated current infeed depth is executed at the calculated position for "automatic" starting point – or at the specified position for "manual" starting point.</p> <p>Note:</p> <p>This setting can be used only if the cutter can cut across center or if the pocket has been predrilled.</p> <ul style="list-style-type: none"> • Helical insertion <p>The cutter center point traverses along the helical path determined by the radius and depth per revolution (helical path). If the depth for one infeed has been reached, a full circle motion is executed to eliminate the inclined insertion path.</p> <ul style="list-style-type: none"> • Oscillating insertion <p>The cutter center point oscillates back and forth along a linear path until it reaches the depth infeed. When the depth has been reached, the path is traversed again without depth infeed in order to eliminate the inclined insertion path.</p>	
FZ  (only for ShopMill)	Depth infeed rate – (only for perpendicular insertion and ∇)	mm/min mm/tooth
FZ (only for G code)	Depth infeed rate – (only for perpendicular insertion and ∇)	*
EP	Maximum pitch of helix – (for helical insertion only)	mm/rev
ER	Radius of helix – (for helical insertion only) The radius cannot be any larger than the cutter radius; otherwise, material will remain.	mm
EW	Maximum insertion angle – (for insertion with oscillation only)	Degrees
Lift mode 	<p>Lift mode before new infeed - (only for ∇, $\nabla\nabla\nabla$ base or $\nabla\nabla\nabla$ edge)</p> <p>If the machining operation requires several points of insertion, the retraction height to which the tool is retracted, is selected as follows:</p> <ul style="list-style-type: none"> • To retraction plane • Z0 + safety clearance <p>If there are no elements larger than Z0 in the pocket area, "Z0 + safety clearance" can be selected as the lift mode.</p>	mm mm
FS	Chamfer width for chamfering - (only for chamfering machining)	mm
ZFS 	Insertion depth of tool tip (abs or inc) - (for machining only)	mm

* Unit of feedrate as programmed before the cycle call

Note

When input manually, the starting point can also be located outside the pocket. This can be useful, for example, when machining a pocket which is open on one side. The machining operation then begins without insertion with a linear movement into the open side of the pocket.

8.3.11 Residual material contour pocket (CYCLE63)

Function

When you have removed stock from a pocket (with/without islands) and there is residual material, then this is automatically detected. You can use a suitable tool to remove this residual material without having to machine the whole pocket again, i.e. avoiding unnecessary non-productive motion. Material that remains as part of the finishing allowance is not residual material.

The residual material is calculated on the basis of the milling cutter used for stock removal.

If you mill several pockets and want to avoid unnecessary tool changes, remove stock from all the pockets first and then remove the residual material. In this case, for removing the residual material, you also have to enter a value for the reference tool TR parameter, which, for the ShopMill program, additionally appears when you press the "All parameters" softkey. When programming, you must then proceed as follows:

1. Contour pocket 1
2. Stock removal
3. Contour pocket 2
4. Stock removal
5. Contour pocket 1
6. Remove residual material
7. Contour pocket 2
8. Remove residual material



Software option

For Stock removal residual material, you require the option "residual material detection and machining".

Procedure



1. The part program or ShopMill program to be processed has been created and you are in the editor.
2. Press the "Contour milling" and "Pocket Res. Mat." softkeys. The "Pocket Res. Mat." input window opens.
3. For the ShopMill program, press the "All parameters" softkey if you want to enter additional parameters.

Parameters, G code program			Parameters, ShopMill program		
PRG	Name of the program to be generated		T	Tool name	
PL	Machining plane		F	Feedrate	mm/min mm/tooth
	Milling direction	<ul style="list-style-type: none"> Synchronous operation Up-cut operation 	S / V	Spindle speed or constant cutting rate	rpm m/min
RP	Retraction plane	mm			
SC	Safety clearance	mm			
F	Feedrate	mm/min			

Parameter	Description	Unit
Machining	The following machining operations can be selected: ▽ (roughing)	
TR	Reference tool Tool, which is used in the "Stock removal" machining step. Is used to determine the residual material.	
D	Cutting edge number	
Z0	Reference point in the tool axis Z	mm
Z1	Pocket depth (abs) or depth referred to Z0 (inc)	mm
DXY	<ul style="list-style-type: none"> Maximum plane infeed Maximum plane infeed as a percentage of the milling cutter diameter 	mm %
DZ	Maximum depth infeed	mm
UXY	Finishing allowance, plane	mm
UZ	Finishing allowance, depth	mm
Lift mode	Lift mode before new infeed If the machining operation requires several points of insertion, the retraction height to which the tool is retracted, is selected as follows: <ul style="list-style-type: none"> To retraction plane Z0 + safety clearance If there are no elements larger than Z0 in the pocket area, "Z0 + safety clearance" can be selected as the lift mode.	mm mm

8.3.12 Milling contour spigot (CYCLE63)

Function

You can mill any spigot using the "Mill spigot" cycle.

Before you mill the spigot, you must first enter a blank contour and then one or more spigot contours. The blank contour defines the area, outside of which there is no material, i.e. the tool moves with rapid traverse there. Material is then removed between the blank contour and spigot contour.

Machining type

You can select the machining mode (roughing, base finishing, edge finishing, chamfer) for milling. If you want to rough and then finish, you have to call the machining cycle twice (Block 1 = roughing, Block 2 = finishing). The programmed parameters are retained when the cycle is called for the second time.







Approach/retraction





1. The tool approaches the starting point in rapid traverse at the height of the retraction plane and goes to the safety clearance. The cycle calculates the starting point.
2. The tool first infeeds to the machining depth and then approaches the spigot contour from the side in a quadrant at machining feedrate.
3. The spigot is machined in parallel with the contours from the outside in. The direction is determined by the machining direction (climbing or conventional).
4. When the first plane of the spigot has been machined, the tool retracts from the contour in a quadrant and then infeeds to the next machining depth.
5. The spigot is again approached in a quadrant and machine in parallel with the contours from outside in.
6. Steps 4 and 5 are repeated until the programmed spigot depth is reached.
7. The tool moves back to the safety clearance in rapid traverse.

Procedure



1. The part program or ShopMill program to be processed has been created and you are in the editor.
2. Press the "Contour milling" and "Spigot" softkeys. The "Mill spigot" input window opens.
3. Select the "Roughing" machining type.

Parameters, G code program			Parameters, ShopMill program		
PRG	Name of the program to be generated		T	Tool name	
PL	Machining plane		D	Cutting edge number	
					
Milling direction 	<ul style="list-style-type: none"> • Climbing cutting • Conventional cutting 		F	Feedrate	mm/min mm/tooth
					
RP	Retraction plane	mm	S / V	Spindle speed or constant cutting rate	rpm m/min
					
SC	Safety clearance	mm			
F	Feedrate	mm/min			

Parameter	Description	Unit
Machining 	The following machining operations can be selected: <ul style="list-style-type: none"> • ▽ (roughing) • ▽▽▽ base (base finishing) • ▽▽▽ edge (edge finishing) • Chamfering 	
Z0	Reference point in the tool axis Z	mm
Z1 	Pocket depth (abs) or depth relative to Z0 (inc) - (only for ▽, ▽▽▽ base or ▽▽▽ edge)	mm
DXY 	<ul style="list-style-type: none"> • Maximum plane infeed • Maximum plane infeed as a percentage of the milling cutter diameter - (only for ▽ and ▽▽▽ base)	mm %
DZ	Maximum depth infeed – (only for ▽ or ▽▽▽ edge)	mm
UXY	Plane finishing allowance – (only for ▽, ▽▽▽ base or ▽▽▽ edge)	mm
UZ	Depth finishing allowance – (only for ▽ or ▽▽▽ base)	mm
Lift mode 	Lift mode before new infeed If the machining operation requires several points of insertion, the retraction height to which the tool is retracted, is selected as follows: <ul style="list-style-type: none"> • To retraction plane • Z0 + safety clearance If there are no elements larger than Z0 (X0) in the pocket area, then Z0 (X0) + safety clearance can be programmed as the lift mode.	mm mm mm
FS	Chamfer width for chamfering - (only for chamfering machining)	mm
ZFS 	Insertion depth of tool tip (abs or inc) - (for machining only)	mm

8.3.13 Residual material contour spigot (CYCLE63)

Function

When you have milled a contour spigot and residual material remains, then this is automatically detected. You can use a suitable tool to remove this residual material without having to machine the whole spigot again, i.e. avoiding unnecessary non-productive motion. Material that remains as part of the finishing allowance is not residual material.

The residual material is calculated on the basis of the milling cutter used for clearing.

If you mill several spigots and want to avoid unnecessary tool changes, clear all the spigots first and then remove the residual material. In this case, for removing the residual material, you also have to enter a value for the reference tool TR parameter, which, for the ShopMill program, additionally appears when you press the "All parameters" softkey. When programming, you must then proceed as follows:

1. Contour blank 1
2. Contour spigot 1
3. Clear spigot 1
4. Contour blank 2
5. Contour spigot 2
6. Clear spigot 2
7. Contour blank 1
8. Contour spigot 1
9. Clear residual material spigot 1
10. Contour blank 2
11. Contour spigot 2
12. Clear residual material spigot 2



Software option

For removing residual material, you require the option "residual material detection and machining".

Procedure

1. The part program or ShopMill program to be processed has been created and you are in the editor.
2. Press the "Contour milling" and "Spigot Res. Mat." softkeys. The "Spigot Res. Mat." input window opens.



3. For the ShopMill program, press the "All parameters" softkey if you want to enter additional parameters.

Parameters, G code program			Parameters, ShopMill program		
PRG	Name of the program to be generated		T	Tool name	
PL	Machining plane		F	Feedrate	mm/min mm/tooth
Milling direction		<ul style="list-style-type: none"> Synchronous operation Up-cut operation 	S / V	Spindle speed or constant cutting rate	rpm m/min
RP	Retraction plane	mm			
SC	Safety clearance	mm			
F	Feedrate	mm/min			

Parameter	Description	Unit
TR	Reference tool Tool, which is used in the "Stock removal" machining step. This is used to determine the residual corners.	
D	Cutting edge number	
Z0	Reference point in the tool axis Z	mm
Z1	Pocket depth (abs) or depth referred to Z0 (inc)	mm
DXY	<ul style="list-style-type: none"> Maximum plane infeed Maximum plane infeed as a percentage of the milling cutter diameter 	mm %
DZ	Maximum depth infeed	mm
Lift mode	Lift mode before new infeed	
	If the machining operation requires several points of insertion, the retraction height to which the tool is retracted, is selected as follows: <ul style="list-style-type: none"> To retraction plane Z0 + safety clearance If there are no elements larger than Z0 in the pocket area, "Z0 + safety clearance" can be selected as the lift mode.	mm mm

8.4 Turning - only for G code programs

8.4.1 General

In all turning cycles apart from contour turning (CYCLE95), in the combined roughing and finishing mode, when finishing it is possible to reduce the feedrate as a percentage.



Machine manufacturer

Please also refer to the machine manufacturer's specifications.

8.4.2 Stock removal (CYCLE951)

8.4.2.1 Function

Function

You can use the "Stock removal" cycle for longitudinal or transverse stock removal of corners at outer or inner contours.

Note

Removing stock from corners

For this cycle, the safety clearance is additionally limited using setting data. The lower value is taken for machining.

Please refer to the machine manufacturer's specifications.

Machining method

- **Roughing**

In roughing applications, paraxial cuts are machined to the finishing allowance that has been programmed. If no finishing allowance has been programmed, the workpiece is roughed down to the final contour.

During roughing, the cycle reduces the programmed infeed depth D if necessary so that it is possible for cuts of an equal size to be made. For example, if the overall infeed depth is 10 and you have specified an infeed depth of 3, this would result in cuts of 3, 3, 3 and 1. The cycle would reduce the infeed depth to 2.5 to create 4 equally sized cuts.

The angle between the contour and the tool cutting edge determines whether the tool rounds the contour at the end of each cut by the infeed depth D, in order to remove residual corners, or is raised immediately. The angle beyond which rounding is performed is stored in a machine data element.



Machine manufacturer

Please also refer to the machine manufacturer's instructions.

If the tool does not round the corner at the end of the cut, it is raised by the safety distance or a value specified in the machine data at rapid traverse. The cycle always observes the lower value; otherwise, stock removal at inner contours, for example, could cause the contour to be damaged.



Machine manufacturer

Please also refer to the machine manufacturer's instructions.

- **Finishing**

Finishing is performed in the same direction as roughing. The cycle automatically selects and deselects tool radius compensation during finishing.

Procedure



1. The part program to be processed has been created and you are in the editor.
 2. Press the "Turning" softkey.
 3. Press the "Stock removal" softkey.
The "Stock Removal" input window opens.
 4. Select one of the three stock removal cycles via the softkeys:
Simple straight stock removal cycle.
The "Stock removal 1" input window opens.
- OR -

8.4 Turning - only for G code programs



Straight stock removal cycle with radii or chamfers.
The "Stock removal 2" input window opens.











- OR -



Stock removal cycle with oblique lines, radii, or chamfers.
The "Stock Removal 3" input window opens.

Parameters, G code program			Parameters, ShopMill program		
PL	Machining plane		T		
SC	Safety clearance	mm	D	Cutting edge number	
F	Feedrate	*	F	Feedrate	mm/min mm/rev
			S / V	Spindle speed or constant cutting rate	rpm m/min

Parameter	Description	Unit
Retraction (for ShopMill program)	<ul style="list-style-type: none"> No The axis is not retracted before swiveling Z Retraction in the direction of machine axis Z Z, X, Y Move machining axes to retraction position before swiveling Tool direction, max. Maximum retraction (up to the software end position) in the tool direction Tool direction, inc. Incremental retraction (specified retraction distance, up to the software end position) in the tool direction <p>When retracting in the tool direction, in the swiveled machine state, several axes can move (travel).</p>	
ZR (for ShopMill program)	Retraction path - only for incremental retraction in the tool direction	
Align tool through beta and gamma angles		

Parameter	Description	Unit
β (for ShopMill program) 	Align tool with swivel axes <ul style="list-style-type: none"> Input value The required angle can be freely entered $\beta = 0^\circ$  $\beta = 90^\circ$  	Degrees
γ (for ShopMill program) 	<ul style="list-style-type: none"> 0° 180° The required angle can be freely entered 	Degrees
Directly position rotary axes		
B1 (for ShopMill program)	Directly align tool with swivel axes: The required angle can be freely entered	Degrees
C1 (for ShopMill program)	The required angle can be freely entered	Degrees
αC (for ShopMill program)	Rotational position for a pole position	Degrees
Hirth tooth system (for ShopMill program)	<ul style="list-style-type: none"> Round off to the next Hirth tooth system for a minimum beta difference  Round beta up  Round beta down  Note: For machines with Hirth gearing	
Tool 	Tool tip when swiveling <ul style="list-style-type: none"> Tracking  The position of the tool tip is maintained during swiveling. No tracking  The position of the tool tip is not maintained during swiveling. 	
Machining 	<ul style="list-style-type: none"> ∇ (roughing) $\nabla\nabla\nabla$ (finishing) 	

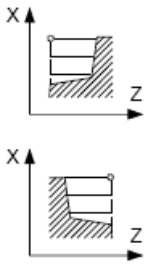
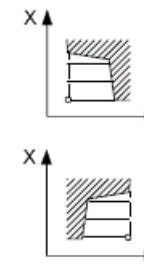
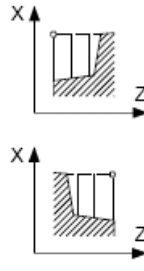
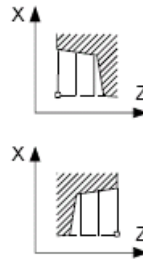
Parameter	Description	Unit
Position U	Stock removal position: 	
Machining direction U	Stock removal direction (longitudinal or transverse) in the coordinate system	
	Parallel to the Z axis (longitudinal)	Parallel to the X axis (transverse)
	<div style="display: flex; justify-content: space-around;"> <div style="text-align: center;"> <p>external</p>  </div> <div style="text-align: center;"> <p>internal</p>  </div> <div style="text-align: center;"> <p>external</p>  </div> <div style="text-align: center;"> <p>internal</p>  </div> </div>	
X0	Reference point in X Ø (abs, always diameter)	mm
Z0	Reference point in Z (abs)	mm
X1 U	End point X (abs) or end point X in relation to X0 (inc)	mm
Z1 U	End point Z Ø (abs) or end point Z in relation to Z0 (inc)	mm
D	Maximum depth infeed – (not for finishing)	mm
UX	Finishing allowance in X – (not for finishing)	mm
UZ	Finishing allowance in Z – (not for finishing)	mm
FS1...FS3 or R1...R3 U	Chamfer width (FS1...FS3) or rounding radius (R1...R3) - (not for stock removal 1)	mm
U	Parameter selection of intermediate point The intermediate point can be determined through position specification or angle. The following combinations are possible - (not for stock removal 1 and 2) <ul style="list-style-type: none"> • XM ZM • XM α1 • XM α2 • α1 ZM • α2 ZM • α1 α2 	
XM U	Intermediate point X Ø (abs) or intermediate point X in relation to X0 (inc)	mm
ZM U	Intermediate point Z (abs or inc)	mm
α1	Angle of the 1st edge	Degrees
α2	Angle of the 2nd edge	Degrees

* Unit of feedrate as programmed before the cycle call

8.4.3 Groove (CYCLE930)

8.4.3.1 Function

Function

You can use the "Groove" cycle to machine symmetrical and asymmetrical grooves on any straight contour elements.

You have the option of machining outer or inner grooves, longitudinally or transversely (face). Use the "Groove width" and "Groove depth" parameters to determine the shape of the groove. If a groove is wider than the active tool, it is machined in several cuts. The tool is moved by a maximum of 80% of the tool width for each groove.

You can specify a finishing allowance for the groove base and the flanks; roughing is then performed down to this point.

The dwell time between recessing and retraction is stored in a setting data element.



Machine manufacturer

Please also refer to the machine manufacturer's specifications.

Approach/retraction during roughing

Infeed depth $D > 0$

1. The tool first moves to the starting point calculated internally in the cycle at rapid traverse.
2. The tool cuts a groove in the center of infeed depth D .
3. The tool moves back by $D + \text{safety clearance}$ with rapid traverse.
4. The tool cuts a groove next to the first groove with infeed depth $2 \cdot D$.
5. The tool moves back by $D + \text{safety clearance}$ with rapid traverse.
6. The tool cuts alternating in the first and second groove with the infeed depth $2 \cdot D$, until the final depth $T1$ is reached.





Between the individual grooves, the tool moves back by $D + \text{safety clearance}$ with rapid traverse. After the last groove, the tool is retracted at rapid traverse to the safety distance.



7. All subsequent groove cuts are made alternating and directly down to the final depth $T1$. Between the individual grooves, the tool moves back to the safety distance at rapid traverse.





Approach/retraction during finishing











1. The tool first moves to the starting point calculated internally in the cycle at rapid traverse.
2. The tool moves at the machining feedrate down one flank and then along the bottom to the center.
3. The tool moves back to the safety distance at rapid traverse.
4. The tool moves at the machining feedrate along the other flank and then along the bottom to the center.
5. The tool moves back to the safety distance at rapid traverse.

Procedure

1. The part program to be processed has been created and you are in the editor.
2. Press the "Turning" softkey.
 
3. Press the "Groove" softkey.
 
4. Select one of the three groove cycles with the softkey:
 - Simple groove cycle
 
 The "Groove 1" input window opens.
 - OR -
 - Groove cycle with inclines, radii, or chamfers.
 
 The "Groove 2" input window opens.
 - OR -
 - Groove cycle on an incline with inclines, radii or chamfers.
 
 The "Groove 3" input window opens.

Parameters, G code program			Parameters, ShopMill program		
PL 	Machining plane		T		
SC	Safety clearance	mm	D	Cutting edge number	
F	Feedrate	*	F 	Feedrate	mm/min mm/rev
			S / V 	Spindle speed or constant cutting rate	rpm m/min

Parameter	Description	Unit
Retraction (for ShopMill program)	<ul style="list-style-type: none"> No The axis is not retracted before swiveling Z Retraction in the direction of machine axis Z Z,X,Y Move machining axes to retraction position before swiveling Tool direction, max. Maximum retraction (up to the software end position) in the tool direction Tool direction, inc. Incremental retraction (specified retraction distance, up to the software end position) in the tool direction <p>When retracting in the tool direction, in the swiveled machine state, several axes can move (travel).</p>	
ZR (for ShopMill program)	Retraction path - only for incremental retraction in the tool direction	mm
Align tool through beta and gamma angles		
β (For ShopMill program) 	<p>Align tool</p> <ul style="list-style-type: none"> Input value The required angle can be freely entered $\beta = 90^\circ$  $\beta = 0^\circ$  	Degrees
γ (for ShopMill program) 	<ul style="list-style-type: none"> 0° 180° The required angle can be freely entered 	
Directly position rotary axes		
B1 (for ShopMill program)	Directly align the tool with the swiveling axes: The required angle can be freely entered	Degrees
C1 (for ShopMill program)	Directly align tool with swivel axes: The required angle can be freely entered	Degrees
αC (for ShopMill program)	Rotational position for a pole position	

Parameter	Description	Unit
Hirth tooth system (for ShopMill program)	<ul style="list-style-type: none"> Round to the next Hirth gearing  Round to Hirth gearing  Round to Hirth gearing  	
Tool 	<p>Tool tip when swiveling</p> <ul style="list-style-type: none"> Tracking  The position of the tool tip is maintained during swiveling. No tracking  The position of the tool tip is not maintained during swiveling. 	
Machining 	<ul style="list-style-type: none"> ∇ (roughing) ∇∇∇ (finishing) ∇ + ∇∇∇ (roughing and finishing) 	
Position 	<p>Groove position/reference point:</p> 	
X0	Reference point in X \emptyset	mm
Z0	Reference point in Z	mm
B1	Groove width	mm
T1	Groove depth \emptyset (abs) or groove depth referred to X0 or Z0 (inc)	mm
α_1, α_2	Edge angle 1 or edge angle 2 - (only for grooves 2 and 3) Asymmetric grooves can be described by separate angles. The angles can be between 0 and $< 90^\circ$.	Degrees
α_0	Angle of inclinations – (only for groove 3)	Degrees
FS1...FS4 or R1...R4 	Chamfer width (FS1...FS4) or rounding radius (R1...R4) - (only for grooves 2 and 3)	mm

Parameter	Description	Unit
D	<ul style="list-style-type: none"> Maximum depth infeed for insertion – (only for ∇ and $\nabla + \nabla\nabla\nabla$) For zero: Insertion in a cut – (only for ∇ and $\nabla + \nabla\nabla\nabla$) <p>D = 0: 1st cut is made directly to final depth T1 D > 0: 1st and 2nd cuts are made alternately to infeed depth D, in order to achieve a better chip flow and prevent the tool from breaking, refer to approaching/retraction when roughing. Alternate cutting is not possible if the tool can only reach the groove base at one position.</p>	mm
UX or U 	Finishing allowance in X or finishing allowance in X and Z – (only for ∇ and $\nabla + \nabla\nabla\nabla$)	mm
UZ	Finishing allowance in Z – (for UX, only for ∇ and $\nabla + \nabla\nabla\nabla$)	mm
N	Number of grooves (N = 1...65535)	
DP	Distance between grooves (inc) DP is not displayed when N = 1	mm

* Unit of feedrate as programmed before the cycle call

8.4.4 Undercut form E and F (CYCLE940)

8.4.4.1 Function

Function

You can use the "Undercut form E" or "Undercut form F" cycle to turn form E or F undercuts in accordance with DIN 509.

Approach/retraction

1. The tool first moves to the starting point calculated internally in the cycle at rapid traverse.
2. The undercut is made in one cut at the machining feedrate, starting from the flank through to the cross-feed VX.
3. The tool moves back to the starting point at rapid traverse.

Procedure



1. The part program or ShopMill program to be processed has been created and you are in the editor.
2. Press the "Turning" softkey.



3. Press the "Undercut" softkey.
The "Undercut" input window opens.







4. Select one of the following undercut cycles via the softkeys:
Press the "Undercut form E" softkey.
The "Undercut form E (DIN 509)" input window opens.









- OR -





- Press the "Undercut form F" softkey.
The "Undercut form F (DIN 509)" input window opens.







Parameters, G code program (undercut, form E)						
PL	Machining plane			T		
SC	Safety clearance	mm		D	Cutting edge number	
F	Feedrate	*		F	Feedrate	mm/min mm/rev
				S / V	Spindle speed or Constant cutting rate	rpm m/min

Parameter	Description	Unit
Retraction (for ShopMill program) 	<ul style="list-style-type: none"> No The axis is not retracted before swiveling Z Retraction in the direction of machine axis Z Z,X,Y Move machining axes to retraction position before swiveling Tool direction, max. Maximum retraction (up to the software end position) in the tool direction Tool direction, inc. Incremental retraction (specified retraction distance, up to the maximum software end position) in the tool direction <p>When retracting in the tool direction, in the swiveled machine state, several axes can move (travel).</p>	
ZR (for ShopMill program)	Retraction path - only for incremental retraction in	mm
Align tool through beta and gamma angles		
β (for ShopMill program) 	<p>Align tool with swivel axes</p> <ul style="list-style-type: none"> Input value The required angle can be freely entered $\beta = 0^\circ$  $\beta = 90^\circ$  	degrees
γ (for ShopMill program) 	<ul style="list-style-type: none"> 0° 180° The required angle can be freely entered 	degrees
Directly position rotary axes		
B1 (for ShopMill program)	Directly align the tool with the swiveling axes: The required angle can be freely entered	degrees
C1 (for ShopMill program)	The required angle can be freely entered	degrees
α C (for ShopMill program)	Rotational position for a pole position	degrees

Parameter	Description	Unit
Hirth tooth system 	<ul style="list-style-type: none"> Round to the next Hirth gearing  Round to Hirth gearing  Round to Hirth gearing  <p>Note: For machines with Hirth tooth system</p>	
Position 	<p>Form E machining position:</p> 	
	<p>Undercut size according to DIN table: E.g.: E1.0 x 0.4 (undercut form E)</p>	
X0	Reference point X \emptyset	mm
Z0	Reference point Z	mm
X1	Allowance in X \emptyset (abs) or allowance in X (inc)	mm
UX 	Cross feed \emptyset (abs) or cross feed (inc)	mm

* Unit of feedrate as programmed before the cycle call

Parameters, G code program (undercut, form F)					
PL 	Machining plane			T	
SC	Safety clearance	mm		D	Cutting edge number
F	Feedrate	*		F 	mm/min mm/rev
				S / V 	rpm m/min

Parameter	Description	Unit
Retraction (for ShopMill program) 	<ul style="list-style-type: none"> No The axis is not retracted before swiveling Z Retraction in the direction of machine axis Z Z, X, Y Move machining axes to retraction position before swiveling Tool direction, max. Maximum retraction (up to the software end position) in the tool direction Tool direction, inc. Incremental retraction (specified retraction distance, up to the software end position) in the tool direction <p>When retracting in the tool direction, in the swiveled machine state, several axes can move (travel).</p>	
Position 	<p>Form F machining position:</p> 	
	Undercut size according to DIN table: e.g.: F0.6 x 0.3 (undercut form F)	
X0	Reference point X \emptyset	mm
Z0	Reference point Z	mm
X1 	Allowance in X \emptyset (abs) or allowance in X (inc)	mm
Z1 	Allowance in Z (abs) or allowance in Z (inc) – (for undercut form F only)	mm
VX 	Cross feed \emptyset (abs) or cross feed (inc)	mm

* Unit of feedrate as programmed before the cycle call

8.4.5 Thread undercut (CYCLE940)

8.4.5.1 Function

Function





The "Thread undercut DIN" or "Thread undercut" cycle is used to program thread undercuts to DIN 76 for workpieces with a metric ISO thread, or freely definable thread undercuts.

Approach/retraction









1. The tool first moves to the starting point calculated internally in the cycle at rapid traverse.
2. The first cut is made at the machining feedrate, starting from the flank and traveling along the shape of the thread undercut as far as the safety distance.
3. The tool moves to the next starting position at rapid traverse.
4. Steps 2 and 3 are repeated until the thread undercut is finished.
5. The tool moves back to the starting point at rapid traverse.

During finishing, the tool travels as far as cross-feed VX.

Procedure









1. The part program to be processed has been created and you are in the editor.
2. Press the "Turning" softkey.

3. Press the "Undercut" softkey.

4. Press the "Thread undercut DIN" softkey.

The "Thread Undercut (DIN 76)" input window opens.
- OR -
Press the "Thread undercut" softkey.

The "Thread Undercut" input window opens.

Parameters, G code program (undercut, thread DIN)		
PL 	Machining plane	
SC	Safety clearance	mm
F	Feedrate	*

Parameter	Description	Unit
Machining 	<ul style="list-style-type: none"> ▽ (roughing) ▽▽▽ (finishing) ▽ + ▽▽▽ (roughing and finishing) 	
Position 	Machining position: 	
Machining direction 	<ul style="list-style-type: none"> Longitudinal Parallel to the contour 	
Form 	<ul style="list-style-type: none"> Normal (form A) Short (form B) 	
P 	Thread pitch (select from the preset DIN table or enter)	mm/rev
X0	Reference point X Ø	mm
Z0	Reference point Z	mm
α	Insertion angle	Degrees
VX 	Cross feed Ø (abs) or cross feed (inc) - (only for ▽▽▽ and ▽ + ▽▽▽)	mm
D	Maximum depth infeed – (only for ▽ and ▽ + ▽▽▽)	mm
U or UX 	Finishing allowance in X or finishing allowance in X and Z – (only for ▽ and ▽ + ▽▽▽)	mm
UZ	Finishing allowance in Z – (only for UX, ▽ and ▽ + ▽▽▽)	mm

* Unit of feedrate as programmed before the cycle call

Parameters, G code program (undercut, thread)			
PL 	Machining plane		
SC	Safety clearance	mm	
F	Feedrate	*	

Parameter	Description	Unit
Machining 	<ul style="list-style-type: none"> ▽ (roughing) ▽▽▽ (finishing) ▽ + ▽▽▽ (roughing and finishing) 	
Machining direction 	<ul style="list-style-type: none"> Longitudinal Parallel to the contour 	
Position 	Machining position: 	
X0	Reference point X \emptyset	mm
Z0	Reference point Z	mm
X1 	Undercut depth referred to X \emptyset (abs) or undercut depth referred to X (inc)	
Z1 	Allowance Z (abs or inc)	
R1	Rounding radius 1	mm
R2	Rounding radius 2	mm
α	Insertion angle	Degrees
VX 	Cross feed \emptyset (abs) or cross feed (inc) - (only for ▽▽▽ and ▽ + ▽▽▽)	
D	Maximum depth infeed – (only for ▽ and ▽ + ▽▽▽)	mm
U or UX 	Finishing allowance in X or finishing allowance in X and Z – (only for ▽ and ▽ + ▽▽▽)	mm
UZ	Finishing allowance in Z – (only for UZ, ▽ and ▽ + ▽▽▽)	mm

* Unit of feedrate as programmed before the cycle call

8.4.6 Thread turning (CYCLE99)

8.4.6.1 Function

Function

The "Longitudinal thread", "Tapered thread" or "Face thread" cycle is used to turn external or internal threads with a constant or variable pitch.

There may be single or multiple threads.

For metric threads (thread pitch P in mm/rev), the cycle assigns a value (calculated on the basis of the thread pitch) to the thread depth H1 parameter. You can change this value.

The default must be activated via setting data SD 55212
\$SCS_FUNCTION_MASK_Tech_SET.



Machine manufacturer

Please refer to the machine manufacturer's specifications.

The cycle requires a speed-controlled spindle with a position measuring system.

Interruption of thread cutting

You have the option to interrupt thread cutting (for example if the cutting tool is broken).

1. Press the <CYCLE STOP> key.

The tool is retracted from the thread and the spindle is stopped.

2. Replace the tool and press the <CYCLE START> key.

The aborted thread cutting is started again with the interrupted cut at the same depth.

Thread re-machining

You have the option of subsequently machining threads. To do this, change into the "JOG" operating mode and carry out a thread synchronization.

Approach/retraction

1. The tool moves to the starting point calculated internally in the cycle at rapid traverse.
2. Thread with advance:



The tool moves at rapid traverse to the first starting position displaced by the thread advance LW.

Thread with run-in:

The tool moves at rapid traverse to the starting position displaced by the thread run-in LW2.

3. The first cut is made with thread pitch P as far as the thread run-out LR.
 4. Thread with advance:
The tool moves at rapid traverse to the return distance VR and then to the next starting position.
Thread with run-in:
The tool moves at rapid traverse to the return distance VR and then back to the starting position.
 5. Steps 3 and 4 are repeated until the thread is finished.
 6. The tool moves back to the retraction plane at rapid traverse.
- Thread machining can be stopped at any time with the "Rapid lift" function. It ensures that the tool does not damage the thread when it is raised.

Procedure for longitudinal thread, tapered thread, or face thread

1. The part program to be processed has been created and you are in the editor.
2. Press the "Turning" softkey.
 
3. Press the "Thread" softkey.
The "Thread" input window opens.
 
4. Press the "Longitudinal thread" softkey.
The "Longitudinal Thread" input window opens.
 

- OR -

 Press the "Tapered thread" softkey.
The "Tapered Thread" input window opens.
 











- OR -

 Press the "Face thread" softkey.
The "Face Thread" input window opens.
 

Parameters, G code program (thread, longitudinal)			
PL 	Machining plane		

Parameter	Description	Unit
Table U	Thread table selection: <ul style="list-style-type: none"> Without ISO metric Whitworth BSW Whitworth BSP UNC 	
Selection - (not for table "Without") U	Data, table value, e.g. M10, M12, M14, ...	
P U	Select the thread pitch / turns for table "without" or specify the thread pitch/turns corresponding to the selection in the thread table: <ul style="list-style-type: none"> Thread pitch in mm/revolution Thread pitch in inch/revolution Thread turns per inch Thread pitch in MODULUS 	mm/rev in/rev turns/" MODULUS
G	Change in thread pitch per revolution – (only for P = mm/rev or in/rev) G = 0: The thread pitch P does not change. G > 0: The thread pitch P increases by the value G per revolution. G < 0: The thread pitch P decreases by the value G per revolution. If the start and end pitch of the thread are known, the pitch change to be programmed can be calculated as follows: $G = \frac{ P_e^2 - P^2 }{2 * Z_1} \text{ [mm/rev}^2\text{]}$ The meanings are as follows: P _e : End pitch of thread [mm/rev] P: Start pitch of thread [mm/rev] Z ₁ : Thread length [mm] A larger pitch results in a larger distance between the thread turns on the workpiece.	mm/rev ²
Machining U	<ul style="list-style-type: none"> ▽ (roughing) ▽▽▽ (finishing) ▽ + ▽▽▽ (roughing and finishing) 	
Infeed (only for ▽ and ▽ + ▽▽▽) U	<ul style="list-style-type: none"> Linear: Infeed with constant cutting depth Degrressive: Infeed with constant cutting cross-section 	
Thread U	<ul style="list-style-type: none"> Internal thread External thread 	
X0	Reference point X from thread table Ø (abs)	mm
Z0	Reference point Z (abs)	mm











8.4 Turning - only for G code programs





Parameter	Description	Unit
Z1 	End point of the thread (abs) or thread length (inc) Incremental dimensions: The sign is also evaluated.	mm
LW  or LW2  or LW2 = LR 	Thread advance (inc) The starting point for the thread is the reference point (X0, Z0) brought forward by the thread advance W. The thread advance can be used if you wish to begin the individual cuts slightly earlier in order to also produce a precise start of thread. Thread run-in (inc) The thread run-in can be used if you cannot approach the thread from the side and instead have to insert the tool into the material (e.g. lubrication groove on a shaft). Thread run-in = thread run-out (inc)	mm mm mm
LR	Thread run-out (inc) The thread run-out can be used if you wish to retract the tool obliquely at the end of the thread (e.g. lubrication groove on a shaft).	mm
H1	Thread depth from thread table (inc)	mm
DP  or αP	Infeed slope as flank (inc) – (alternative to infeed slope as angle) DP > 0: Infeed along the rear flank DP < 0: Infeed along the front flank Infeed slope as angle – (alternative to infeed slope as flank) $\alpha > 0$: Infeed along the rear flank $\alpha < 0$: Infeed along the front flank $\alpha = 0$: Infeed at right angle to cutting direction If you wish to infeed along the flanks, the maximum absolute value of this parameter may be half the flank angle of the tool.	 Degrees
  	Infeed along the flank Infeed with alternating flanks (alternative) Instead of infeed along one flank, you can infeed along alternating flanks to avoid always loading the same tool cutting edge. As a consequence you can increase the tool life. $\alpha > 0$: Start at the rear flank $\alpha < 0$: Start at the front flank	
D1 or ND  (only for ∇ and $\nabla + \nabla\nabla\nabla$)	First infeed depth or number of roughing cuts The respective value is displayed when you switch between the number of roughing cuts and the first infeed.	mm
rev	Finishing allowance in X and Z – (only for ∇ and $\nabla + \nabla\nabla\nabla$)	mm
NN	Number of noncuts - (only for $\nabla\nabla\nabla$ and $\nabla + \nabla\nabla\nabla$)	
VR	Return distance (inc)	mm
Multiple threads 	No $\alpha 0$ Starting angle offset Yes N Number of thread turns The thread turns are distributed evenly across the periphery of the turned part; the 1st thread turn is always located at 0°.	 Degrees

Parameter	Description		Unit
	DA	Thread changeover depth (inc) First machine all thread turns sequentially to thread changeover depth DA, then machine all thread turns sequentially to depth 2 · DA, etc. until the final depth is reached. DA = 0: Thread changeover depth is not taken into account, i.e. finish machining each thread before starting the next thread.	mm
	Machining: U	<ul style="list-style-type: none"> Complete, or from turn N1 N1 (1...4) start thread N1 = 1...N U or only thread NX NX (1...4) 1 from N threads U 	

Parameters, G code program (thread, face)			
PL U	Machining plane		









Parameter	Description	Unit
P U	<ul style="list-style-type: none"> Thread pitch in mm/revolution Thread pitch in inch/revolution Thread turns per inch Thread pitch in MODULUS 	mm/rev in/rev turns/" MODULUS
G	<p>Change in thread pitch per revolution – (only for P = mm/rev or in/rev)</p> <p>G = 0: The thread pitch P does not change. G > 0: The thread pitch P increases by the value G per revolution. G < 0: The thread pitch P decreases by the value G per revolution.</p> <p>If the start and end pitch of the thread are known, the pitch change to be programmed can be calculated as follows:</p> $G = \frac{ P_e^2 - P^2 }{2 * Z_1} \text{ [mm/rev}^2\text{]}$ <p>The meanings are as follows: P_e: End pitch of thread [mm/rev] P: Start pitch of thread [mm/rev] Z₁: Thread length [mm]</p> <p>A larger pitch results in a larger distance between the thread turns on the workpiece.</p>	mm/rev ²
Machining U	<ul style="list-style-type: none"> ▽ (roughing) ▽▽▽ (finishing) ▽ + ▽▽▽ (roughing and finishing) 	

Parameter	Description	Unit
Infeed (only for ∇ and $\nabla + \nabla\nabla\nabla$) 	<ul style="list-style-type: none"> Linear: Infeed with constant cutting depth Degressive: Infeed with constant cutting cross-section 	
Thread 	<ul style="list-style-type: none"> Internal thread External thread 	
X0	Reference point X \varnothing (abs, always diameter)	mm
Z0	Reference point Z (abs)	mm
X1 	End point of the thread \varnothing (abs) or thread length (inc) Incremental dimensions: The sign is also evaluated.	mm
LW  or LW2  or LW2 = LR 	<p>Thread advance (inc) The starting point for the thread is the reference point (X0, Z0) brought forward by the thread advance W. The thread advance can be used if you wish to begin the individual cuts slightly earlier in order to also produce a precise start of thread.</p> <p>Thread run-in (inc) The thread run-in can be used if you cannot approach the thread from the side and instead have to insert the tool into the material (e.g. lubrication groove on a shaft). Thread run-in = thread run-out (inc)</p>	mm mm mm
LR	Thread run-out (inc) The thread run-out can be used if you wish to retract the tool obliquely at the end of the thread (e.g. lubrication groove on a shaft).	mm
H1	Thread depth (inc)	mm
DP  or αP	<p>Infeed slope as flank (inc) – (alternative to infeed slope as angle) DP > 0: Infeed along the rear flank DP < 0: Infeed along the front flank</p> <p>Infeed slope as angle – (alternative to infeed slope as flank) α > 0: Infeed along the rear flank α < 0: Infeed along the front flank α = 0: Infeed at right angle to cutting direction If you wish to infeed along the flanks, the maximum absolute value of this parameter may be half the flank angle of the tool.</p>	Degrees
  	<p>Infeed along the flank Infeed with alternating flanks (alternative) Instead of infeed along one flank, you can infeed along alternating flanks to avoid always loading the same tool cutting edge. As a consequence you can increase the tool life. α > 0: Start at the rear flank α < 0: Start at the front flank</p>	
D1 or ND  (only for ∇ and $\nabla + \nabla\nabla\nabla$)	First infeed depth or number of roughing cuts The respective value is displayed when you switch between the number of roughing cuts and the first infeed.	mm

Parameter	Description	Unit	
rev	Finishing allowance in X and Z – (only for ∇ and $\nabla + \nabla\nabla\nabla$)	mm	
NN	Number of noncuts - (only for $\nabla\nabla\nabla$ and $\nabla + \nabla\nabla\nabla$)		
VR	Return distance (inc)	mm	
Multiple threads 	No		
	$\alpha 0$	Starting angle offset	Degrees
	Yes		
	N	Number of thread turns The thread turns are distributed evenly across the periphery of the turned part; the 1st thread turn is always located at 0°.	
	DA	Thread changeover depth (inc) First machine all thread turns sequentially to thread changeover depth DA, then machine all thread turns sequentially to depth 2 · DA, etc. until the final depth is reached. DA = 0: Thread changeover depth is not taken into account, i.e. finish machining each thread before starting the next thread.	mm
Machining: 	<ul style="list-style-type: none"> Complete, or from turn N1 N1 (1...4) start thread N1 = 1...N  or only thread NX NX (1...4) 1 from N threads  		

Parameters, G code program (thread, conical)			
PL 	Machining plane		

Parameter	Description	Unit
P 	<ul style="list-style-type: none"> Thread pitch in mm/revolution Thread pitch in inch/revolution Thread turns per inch Thread pitch in MODULUS 	mm/rev in/rev turns/" MODULUS

Parameter	Description	Unit
G	<p>Change in thread pitch per revolution – (only for P = mm/rev or in/rev)</p> <p>G = 0: The thread pitch P does not change.</p> <p>G > 0: The thread pitch P increases by the value G per revolution.</p> <p>G < 0: The thread pitch P decreases by the value G per revolution.</p> <p>If the start and end pitch of the thread are known, the pitch change to be programmed can be calculated as follows:</p> $G = \frac{ P_e^2 - P^2 }{2 * Z_1} \text{ [mm/rev}^2\text{]}$ <p>The meanings are as follows:</p> <p>P_e: End pitch of thread [mm/rev] P: Start pitch of thread [mm/rev] Z₁: Thread length [mm]</p> <p>A larger pitch results in a larger distance between the thread turns on the workpiece.</p>	mm/rev ²
Machining 	<ul style="list-style-type: none"> ∇ (roughing) ∇∇∇ (finishing) ∇ + ∇∇∇ (roughing and finishing) 	
Infeed (only for ∇ and ∇ + ∇∇∇) 	<ul style="list-style-type: none"> Linear: Infeed with constant cutting depth Degressive: Infeed with constant cutting cross-section 	
Thread 	<ul style="list-style-type: none"> Internal thread External thread 	
X0	Reference point X Ø (abs, always diameter)	mm
Z0	Reference point Z (abs)	mm
X1 or X1α 	<p>End point X Ø (abs) or end point in relation to X0 (inc) or Thread taper</p> <p>Incremental dimensions: The sign is also evaluated.</p>	mm or degrees
Z1 	<p>End point Z (abs) or end point in relation to Z0 (inc)</p> <p>Incremental dimensions: The sign is also evaluated.</p>	mm
LW  or LW2  or LW2 = LR 	<p>Thread advance (inc)</p> <p>The starting point for the thread is the reference point (X0, Z0) brought forward by the thread advance W. The thread advance can be used if you wish to begin the individual cuts slightly earlier in order to also produce a precise start of thread.</p> <p>Thread run-in (inc)</p> <p>The thread run-in can be used if you cannot approach the thread from the side and instead have to insert the tool into the material (e.g. lubrication groove on a shaft).</p> <p>Thread run-in = thread run-out (inc)</p>	mm mm mm

8.4.7 Thread chain (CYCLE98)

8.4.7.1 Function

Function

With this cycle, you can produce several concatenated cylindrical or tapered threads with a constant pitch in longitudinal and face machining, all of which can have different thread pitches.

There may be single or multiple threads. With multiple threads, the individual thread turns are machined one after the other.

You define a right or left-hand thread by the direction of spindle rotation and the feed direction.

The infeed is performed automatically with a constant infeed depth or constant cutting cross-section.

- With a constant infeed depth, the cutting cross-section increases from cut to cut. The finishing allowance is machined in one cut after roughing.

A constant infeed depth can produce better cutting conditions at small thread depths.

- With a constant cutting cross-section, the cutting pressure remains constant over all roughing cuts and the infeed depth is reduced.

The feedrate override has no effect during traversing blocks with thread. The spindle override must not be changed during the thread machining.

Interruption of thread cutting

You have the option to interrupt thread cutting (for example if the cutting tool is broken).

1. Press the <CYCLE STOP> key.

The tool is retracted from the thread and the spindle is stopped.

2. Replace the tool and press the <CYCLE START> key.

The aborted thread cutting is started again with the interrupted cut at the same depth.

Approach/retraction

1. Approach of the starting point determined in the cycle at the beginning of the run-in path for the first thread with G0
2. Infeed for roughing according to the defined infeed type.
3. Thread cutting is repeated according to the programmed number of roughing cuts.
4. The finishing allowance is removed in the following step with G33.
5. This cut is repeated according to the number of noncuts.
6. The whole sequence of motions is repeated for each further thread.









Procedure for thread chain



1. The part program to be executed has been created and you are in the editor.
2. Press the "Turning" softkey.
3. Press the "Thread" softkey.
The "Thread" input window opens.
4. Press the "Thread chain" softkey.
The "Thread Chain" input window opens.

Parameters, G code program			
PL	Machining plane		

Parameter	Description	Unit
Machining 	<ul style="list-style-type: none"> • ∇ (roughing) • ∇∇∇ (finishing) • ∇ + ∇∇∇ (roughing and finishing) 	
Infeed (only for ∇ and ∇ + ∇∇∇) 	<ul style="list-style-type: none"> • Linear: Constant cutting depth infeed • Degressive: Constant cutting cross-section infeed 	
Thread 	<ul style="list-style-type: none"> • Internal thread • External thread 	
X0	Reference point X Ø (abs, always diameter)	mm
Z0	Reference point Z (abs)	mm
P0	Thread pitch 1	mm/rev in/rev turns/" MODULUS
X1 or X1α 	<ul style="list-style-type: none"> • Intermediate point 1 X Ø (abs) or • Intermediate point 1 in relation to X0 (inc) or • Thread taper 1 Incremental dimensions: The sign is also evaluated.	mm Degrees
Z1	<ul style="list-style-type: none"> • Intermediate point 1 Z (abs) or • Intermediate point 1 in relation to Z0 (inc) 	mm

Parameter	Description	Unit	
P1	Thread pitch 2 (unit as parameterized for P0)	mm/rev in/rev turns/" MODULUS	
X2 or X2α 	<ul style="list-style-type: none"> Intermediate point 2 X Ø (abs) or Intermediate point 2 in relation to X1 (inc) or Thread taper 2 Incremental dimensions: The sign is also evaluated.	mm Degrees	
Z2 	<ul style="list-style-type: none"> Intermediate point 2 Z (abs) or Intermediate point 2 in relation to Z1 (inc) 	mm	
P2	Thread pitch 3 (unit as parameterized for P0)	mm/rev in/rev turns/" MODULUS	
X3 	<ul style="list-style-type: none"> End point X Ø (abs) or End point 3 in relation to X2 (inc) or Thread taper 3 	mm Degrees	
Z3 	<ul style="list-style-type: none"> End point Z Ø (abs) or End point with reference to Z2 (inc) 	mm	
LW	Thread run-in	mm	
LR	Thread run-out	mm	
H1	Thread depth	mm	
DP or αP 	Infeed slope (flank) or infeed slope (angle)	mm or degrees	
 	<ul style="list-style-type: none"> Infeed along a flank Infeed with alternating flanks 		
D1 or ND 	First infeed depth or number of roughing cuts - (only for ▽ and ▽ + ▽▽▽)	mm	
rev	Finishing allowance in X and Z - (only for ▽ and ▽ + ▽▽▽)	mm	
NN	Number of noncuts - (only for ▽▽▽ and ▽ + ▽▽▽)		
VR	Return distance	mm	
Multiple threads 	No		
	α0	Starting angle offset	Degrees
	Yes		
	N	Number of thread turns	
	DA	Thread changeover depth (inc)	mm

8.4.8 Cut-off (CYCLE92)

Function

The "Cut-off" cycle is used when you want to cut off dynamically balanced parts (e.g. screws, bolts, or pipes).

You can program a chamfer or rounding on the edge of the machined part. You can machine at a constant cutting rate V or speed S up to a depth X1, from which point the workpiece is machined at a constant speed. As of depth X1, you can also program a reduced feedrate FR or a reduced speed SR, in order to adapt the velocity to the smaller diameter.

Use parameter X2 to enter the final depth that you wish to reach with the cut-off. With pipes, for example, you do not need to cut-off until you reach the center; cutting off slightly more than the wall thickness of the pipe is sufficient.

Approach/retraction

1. The tool first moves to the starting point calculated internally in the cycle at rapid traverse.
2. The chamfer or radius is machined at the machining feedrate.
3. Cut-off down to depth X1 is performed at the machining feedrate.
4. Cut-off is continued down to depth X2 at reduced feedrate FR and reduced speed SR.
5. The tool moves back to the safety distance at rapid traverse.

If your turning machine is appropriately set up, you can extend a workpiece drawer (part catcher) to accept the cut-off workpiece. Extension of the workpiece drawer must be enabled in a machine data element.



Machine manufacturer







Please refer to the machine manufacturer's specifications.

Procedure



1. The part program to be executed has been created and you are in the editor.
2. Press the "Turning" softkey.
3. Press the "Cut-off" softkey.
The "Cut-off" input window opens.

Parameters, G code program			
PL 	Machining plane		
SC	Safety clearance	mm	
F	Feedrate	*	

Parameter	Description	Unit
DIR 	Direction of spindle rotation  	
S	Spindle speed	rev/min
V	Constant cutting rate	mm/min
SV	Maximum speed limit - (only for constant cutting rate V)	rev/min
X0	Reference point in X \varnothing (abs, always diameter)	mm
Z0	Reference point in Z (abs)	mm
FS or R 	Chamfer width or rounding radius	mm
X1 	Depth for speed reduction \varnothing (abs) or depth for speed reduction in relation to X0 (inc)	mm
FR	Reduced feedrate	*
SR	Reduced speed	rev/min
X2 	Final depth \varnothing (abs) or final depth in relation to X1 (inc)	mm

* Unit of feedrate as programmed before the cycle call

8.5 Contour turning- only for G code programs

8.5.1 General information

Function

You can machine simple or complex contours with the "Contour turning" cycle. A contour comprises separate contour elements, whereby at least two and up to 250 elements result in a defined contour.

You can program chamfers, radii, undercuts or tangential transitions between the contour elements.

The integrated contour calculator calculates the intersection points of the individual contour elements taking into account the geometrical relationships, which allows you to enter incompletely dimensioned elements.

When you machine the contour, you can make allowance for a blank contour which must be entered before the finished-part contour. Then select one of the the following machining technologies:

- Stock removal
- Grooving
- Plunge-turning

You can rough, remove residual material and finish for each of the three technologies above.

Programming

For example, the programming procedure for stock removal is as follows:

Note

When programming in the G code, it must be ensured that the contours are located after the end of program identifier!

1. Enter the unmachined-part contour

If, when removing stock along the contour, you want to take into account an unmachined part contour (and no cylinder or no allowance) as unmachined part shape, then you must define the contour of the unmachined part before you define the finished-part contour. Compile the unmachined-part contour step-by-step from various contour elements.

2. Enter finished-part contour

You build up the finished-part contour gradually from a series of different contour elements.

3. Contour call

4. Stock removal along the contour (roughing)

The contour is machined longitudinally, transversely or parallel to the contour.

5. Remove residual material (roughing)

For G code programming, when removing stock, it must first be decided whether to rough (machine) with residual material detection or not. A suitable tool will allow you to remove this without having to machine the contour again.

6. Stock removal along the contour (finishing)

If you programmed a finishing allowance for roughing, the contour is machined again.









8.5.2 Representation of the contour

G code program

In the editor, the contour is represented in a program section using individual program blocks. If you open an individual block, then the contour is opened.

Symbolic representation

The individual contour elements are represented by symbols adjacent to the graphics window. They appear in the order in which they were entered.

Contour element	Symbol	Meaning
Starting point		Starting point of the contour
Straight line up		Straight line in 90° grid
Straight line down		Straight line in 90° grid
Straight line left		Straight line in 90° grid
Straight line right		Straight line in 90° grid
Straight line in any direction		Straight line with any gradient
Arc right		Circle
Arc left		Circle
Pole		Straight diagonal or circle in polar coordinates
Finish contour	END	End of contour definition

The different colors of the symbols indicate their status:

Foreground	Background	Meaning
Black	Blue	Cursor on new element
Black	Orange	Cursor on current element
Black	White	Normal element
Red	White	Element not currently evaluated (element will only be evaluated when it is selected with the cursor)

Graphical display

The progress of contour programming is shown in broken-line graphics while the contour elements are being entered.

When the contour element has been created, it can be displayed in different line styles and colors:

- Black: Programmed contour
- Orange: Current contour element
- Green dashed: Alternative element
- Blue dotted: Partially defined element

The scaling of the coordinate system is adjusted automatically to match the complete contour.

The position of the coordinate system is displayed in the graphics window.

8.5.3 Creating a new contour

Function

For each contour that you want to cut, you must create a new contour.

The first step in creating a contour is to specify a starting point. Enter the contour element. The contour processor then automatically defines the end of the contour.

Procedure

1. The part program to be executed has been created and you are in the editor.
2. Press the "Turning" and "Contour turning" softkeys.



8.5 Contour turning- only for G code programs









3. Press the "Contour" and "New contour" softkeys.
The "New Contour" input window opens.

4. Enter a name for the new contour. The contour name must be unique.

5. Press the "Accept" softkey.

The input window for the starting point of the contour appears.

Enter the individual contour elements (see Section "Creating contour elements").

Parameter	Description	Unit
Z	Starting point Z (abs)	mm
X	Starting point X Ø (abs)	mm
Transition to contour start 	Type of transition <ul style="list-style-type: none"> • Radius • Chamfer FS=0 or R=0: No transition element	
R	Transition to following element – radius	mm
FS	Transition to following element – chamfer	mm
Direction in front of the contour 	Direction of the contour element towards the starting point: <ul style="list-style-type: none">  • In the negative direction of the horizontal axis  • In the positive direction of the horizontal axis  • In the negative direction of the vertical axis  • In the positive direction of the vertical axis 	

Parameter	Description	Unit
Additional commands	<p>You can enter additional commands in the form of G code for each contour element. You can enter the additional commands (max. 40 characters) in the extended parameter screens ("All parameters" softkey). The softkey is always available at the starting point, it only has to be pressed when entering additional contour elements.</p> <p>You can program feedrates and M commands, for example, using additional G code commands. However, carefully ensure that the additional commands do not collide with the generated G code of the contour and are compatible with the machining type required. Therefore, do not use any G code commands of group 1 (G0, G1, G2, G3), no coordinates in the plane and no G code commands that have to be programmed in a separate block.</p> <p>The contour is finished in continuous-path mode (G64). As a result, contour transitions such as corners, chamfers or radii may not be machined precisely.</p> <p>If you wish to avoid this, then it is possible to use additional commands when programming.</p> <p>Example: For a contour, first program the straight X parallel and then enter "G9" (non-modal exact stop) for the additional command parameter. Then program the Z-parallel straight line. The corner will be machined exactly, as the feedrate at the end of the X-parallel straight line is briefly zero.</p> <p>Note: The additional commands are only effective for finishing!</p>	

8.5.4 Creating contour elements

Creating contour elements

After you have created a new contour and specified the starting point, you can define the individual elements that make up the contour.

The following contour elements are available for the definition of a contour:

- Straight vertical line
- Straight horizontal line
- Diagonal line
- Circle/arc

For each contour element, you must parameterize a separate parameter screen. Parameter entry is supported by various help screens that explain the parameters.

If you leave certain fields blank, the cycle assumes that the values are unknown and attempts to calculate them from other parameters.

Conflicts may result if you enter more parameters than are absolutely necessary for a contour. In such a case, try entering less parameters and allowing the cycle to calculate as many parameters as possible.

Contour transition elements

As transition element between two contour elements, you can select a radius or a chamfer or, in the case of linear contour elements, an undercut. The transition element is always attached at the end of a contour element. The contour transition element is selected in the parameter screen of the respective contour element.

You can use a contour transition element whenever there is an intersection between two successive elements which can be calculated from the input values. Otherwise you must use the straight/circle contour elements.

Additional commands

You can enter additional commands in the form of G code for each contour element. You can enter the additional commands (max. 40 characters) in the extended parameter screens ("All parameters" softkey).

You can program feedrates and M commands, for example, using additional G code commands. However, make sure that the additional commands do not collide with the generated G code of the contour. Therefore, do not use any G code commands of group 1 (G0, G1, G2, G3), no coordinates in the plane and no G code commands that have to be programmed in a separate block.

Additional functions

The following additional functions are available for programming a contour:

- Tangent to preceding element

You can program the transition to the preceding element as tangent.

- Selecting a dialog box

If two different possible contours result from the parameters entered thus far, one of the options must be selected.

- Close contour

From the actual position, you can close the contour with a straight line to the starting point.

Producing exact contour transitions

The axis moves in the continuous path mode (G64). As a result, contour transitions such as corners, chamfers or radii may not be machined precisely.

If you wish to avoid this, there are two different options when programming. Use the additional programs or program the special feedrate for the transition element.

- Additional command

For a contour, first program the vertical straight line and then enter "G9" (non-modal exact stop) for the additional command parameter. Then program the horizontal straight line. The corner will be machined exactly, since the feedrate at the end of the vertical straight line is briefly zero.

- Feedrate, transition element

If you have chosen a chamfer or a radius as the transition element, enter a reduced feedrate in the "FRC" parameter. The slower machining rate means that the transition element is machined more accurately.

Procedure for entering contour elements

1. The part program is opened. Position the cursor at the required input position, this is generally at the physical end of the program after M02 or M30.
2. Contour input using contour support:
 - 2.1 Press the "Contour turning", "Contour" and "New contour" softkeys.







 - 2.2 In the opened input window, enter a name for the contour, e.g. contour_1.
 Press the "Accept" softkey.



 - 2.3 The input screen to enter the contour opens, in which you initially enter a starting point for the contour. This is marked in the lefthand navigation bar using the "+" symbol.
 Press the "Accept" softkey.

3. Enter the individual contour elements of the machining direction.
 Select a contour element via softkey.



The "Straight (e.g. Z)" input window opens.

- OR



The "Straight (e.g. X)" input window opens.

- OR



The "Straight (e.g. ZX)" input window opens.

- OR



The "Circle" input window opens.
4. Enter all the data available from the workpiece drawing in the input screen (e.g. length of straight line, target position, transition to next element, angle of lead, etc.).
5. Press the "Accept" softkey.
 The contour element is added to the contour.





6. When entering data for a contour element, you can program the transition to the preceding element as a tangent.
Press the "Tangent to prec. elem." softkey. The "tangential" selection appears in the parameter $\alpha 2$ entry field.



7. Repeat the procedure until the contour is complete.
8. Press the "Accept" softkey.
The programmed contour is transferred into the process plan (program view).

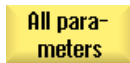

9. If you want to display further parameters for certain contour elements, e.g. to enter additional commands, press the "All parameters" softkey.

Contour element "Straight line e.g. Z"



Parameters	Description	Unit
Z	End point Z (abs or inc)	mm
$\alpha 1$	Starting angle to Z axis	Degrees
$\alpha 2$	Angle to the preceding element	Degrees
Transition to next element	Type of transition <ul style="list-style-type: none"> • Radius • Undercut • Chamfer 	
Radius	R Transition to following element - radius	mm
Undercut	Form E Undercut size e.g. E1.0x0.4	
	Form F Undercut size e.g. F0.6x0.3	
	DIN thread P Thread pitch α Insertion angle	mm/rev Degrees
	Thread Z1 Length Z1 Z2 Length Z2 R1 Radius R1 R2 Radius R2 T Insertion depth	mm mm mm mm mm
Chamfer	FS Transition to following element - chamfer	mm
CA	Grinding allowance <ul style="list-style-type: none"> • Grinding allowance to right of contour • Grinding allowance to left of contour 	mm
Additional commands	Additional G code commands	

Contour element "Straight line e.g. X"











Parameters	Description	Unit
X	End point X \varnothing (abs) or end point X (inc)	mm
$\alpha 1$	Starting angle to Z axis	Degrees
$\alpha 2$	Angle to the preceding element	Degrees
Transition to next element	Type of transition <ul style="list-style-type: none"> Radius Undercut Chamfer 	
Radius	R Transition to following element - radius	mm
Undercut	Form E Undercut size e.g. E1.0x0.4	
	Form F Undercut size e.g. F0.6x0.3	
	DIN thread P Thread pitch α Insertion angle	mm/rev Degrees
	Thread Z1 Length Z1 Z2 Length Z2 R1 Radius R1 R2 Radius R2 T Insertion depth	mm mm mm mm mm
Chamfer	FS Transition to following element - chamfer	mm
CA	Grinding allowance <ul style="list-style-type: none"> Grinding allowance to right of contour Grinding allowance to left of contour 	mm
Additional commands	Additional G code commands	

Contour element "Straight line e.g. ZX"

Parameters	Description	Unit
Z	End point Z (abs or inc)	mm
X	End point X \varnothing (abs) or end point X (inc)	mm
$\alpha 1$	Starting angle to Z axis	Degrees
$\alpha 2$	Angle to the preceding element	Degrees
Transition to next element	Type of transition <ul style="list-style-type: none"> Radius Chamfer 	
Radius	R Transition to following element - radius	mm
Chamfer	FS Transition to following element - chamfer	mm

Parameters	Description	Unit
CA	Grinding allowance  <ul style="list-style-type: none">  Grinding allowance to right of contour  Grinding allowance to left of contour 	mm
Additional commands	Additional G code commands	

Contour element "Circle"

Parameters	Description	Unit
Direction of rotation 	<ul style="list-style-type: none"> Clockwise direction of rotation  Counterclockwise direction of rotation  	
Z 	End point Z (abs or inc)	mm
X 	End point X \emptyset (abs) or end point X (inc)	mm
K 	Circle center point K (abs or inc)	mm
I 	Circle center point I \emptyset (abs or circle center point I (inc)	mm
$\alpha 1$	Starting angle to Z axis	Degrees
$\beta 1$	End angle to Z axis	Degrees
$\beta 2$	Opening angle	Degrees
Transition to next element 	Type of transition <ul style="list-style-type: none"> Radius Chamfer 	
Radius	R Transition to following element - radius	mm
Chamfer	FS Transition to following element - chamfer	mm
CA	Grinding allowance  <ul style="list-style-type: none">  Grinding allowance to right of contour  Grinding allowance to left of contour 	mm
Additional commands	Additional G code commands	

Contour element "End"

The data for the transition at the contour end of the previous contour element is displayed in the "End" parameter screen.

The values cannot be edited.

8.5.5 Changing the contour

Function

You can change a previously created contour later.

Individual contour elements can be

- added,
- changed,
- inserted or
- deleted.

Procedure for changing a contour element

1. Open the part program to be executed.
2. With the cursor, select the program block where you want to change the contour. Open the geometry processor.
The individual contour elements are listed.
3. Position the cursor at the position where a contour element is to be inserted or changed.
4. Select the desired contour element with the cursor.
5. Enter the parameters in the input screen or delete the element and select a new element.
6. Press the "Accept" softkey.
The desired contour element is inserted in the contour or changed.



Procedure for deleting a contour element

1. Open the part program to be executed.
2. Position the cursor on the contour element that you want to delete.
3. Press the "Delete element" softkey.
4. Press the "Delete" softkey.



8.5.6 Contour call (CYCLE62)

8.5.6.1 Function

Function

The input creates a reference to the selected contour.

There are four ways to call the contour:

1. Contour name

The contour is in the calling main program.

2. Labels

The contour is in the calling main program and is limited by the labels that have been entered.





3. Subprogram

The contour is located in a subprogram in the same workpiece.

4. Labels in the subprogram

The contour is in a subprogram and is limited by the labels that have been entered.

Procedure

1. The part program to be executed has been created and you are in the editor.
2. Press the "Turning" and "Contour turning" softkeys.

3. Press the "Contour" and "Contour call" softkeys.
The "Contour Call" input window opens.

4. Assign parameters to the contour selection.

Parameter	Description	Unit
Contour selection 	<ul style="list-style-type: none"> • Contour name • Labels • Subprogram • Labels in the subprogram 	
Contour name	CON: Contour name	
Labels	<ul style="list-style-type: none"> • LAB1: Label 1 • LAB2: Label 2 	
Subprogram	PRG: Subprogram	
Labels in the subprogram	<ul style="list-style-type: none"> • PRG: Subprogram • LAB1: Label 1 • LAB2: Label 2 	

8.5.7 Stock removal (CYCLE952)

8.5.7.1 Function

Function

For stock removal, the cycle takes into account a blank that can comprise a cylinder, an allowance on the finished-part contour or any blank contour. You must define a blank contour as a separate closed contour in advance of the finished-part contour.

Precondition

For a G-code program, at least one CYCLE62 is required before CYCLE952.

If CYCLE62 is only present once, then this involves the finished part contour.

If CYCLE62 is present twice, then the first call is the blank contour and the second call is the finished-part contour (also see Chapter "Programming").

Rounding the contour

In order to avoid residual corners during roughing, you can enable the "Always round the contour" function. This will remove the protrusions that are always left at the end with each cut (due to the cut geometry). The "Round to the previous intersection" setting accelerates machining of the contour. However, any resulting residual corners will not be recognized or machined. Thus, it is imperative that you check the behavior before machining using the simulation.

When set to "automatic", rounding is always performed if the angle between the cutting edge and the contour exceeds a certain value. The angle is set in a machine data element.



Machine manufacturer

Please refer to the machine manufacturer's specifications.

Alternating cutting depth

Instead of working with constant cutting depth D, you can use an alternating cutting depth to vary the load on the tool edge, As a consequence you can increase the tool life.

The percentage for the alternating cutting depth is saved in a machine data element.



Machine manufacturer

Please refer to the machine manufacturer's specifications.

Cut segmentation

To avoid the occurrence of very thin cuts in cut segmentation due to contour edges, you can align the cut segmentation to the contour edges. During machining the contour is then divided by the edges into individual sections and cut segmentation is performed separately for each section.

Set machining area limits

If, for example, you want to machine a certain area of the contour with a different tool, you can set machining area limits so that machining only takes place in the area of the contour you have selected. You can define between 1 and 4 limit lines.

Feedrate interruption

To prevent the occurrence of excessively long chips during machining, you can program a feedrate interruption. Parameter DI specifies the distance after which the feedrate interruption should occur.

Residual material machining / naming conventions

G code program

For multi-channel systems, cycles attach a "_C" and a two-digit number of the specific channel to the names of the programs to be generated, e.g. for channel 1 "_C01".

This is the reason that the name of the main program must not end with "_C" and a two-digit number. This is monitored by the cycles.

For programs with residual machining, when specifying the name for the file, which includes the updated blank contour, it must be ensured that this does not have the attached characters ("_C" and double-digit number).

For single-channel systems, cycles do not extend the name for the programs to be generated.

Note

G code programs

For G code programs, the programs to be generated, which do not include any path data, are saved in the directory in which the main program is located. In this case, it must be ensured that programs, which already exist in the directory and which have the same name as the programs to be generated, are overwritten.

Machining type

You can select the machining mode (roughing or finishing). During contour roughing, parallel cuts of maximum programmed infeed depth are created. Roughing is performed to the programmed allowance.

You can also specify a compensation allowance U1 for finishing operations, which allows you to either finish several times (positive allowance) or to shrink the contour (negative allowance). Finishing is performed in the same direction as roughing.











Procedure







1. The part program to be executed has been created and you are in the editor.
2. Press the "Turning" and "Contour turning" softkeys.
3. Press the "Stock removal" softkey.
The "Stock Removal" input window opens.

Parameter G code program			
PRG	Name of the program to be generated		
PL <input checked="" type="checkbox"/>	Machining plane		
RP	Retraction plane – (only for machining direction, longitudinal, inner)	mm	
SC	Safety clearance	mm	
F	Feed (∇ or ∇∇∇)	*	
FS	Finishing feedrate (only for complete machining: ∇ + ∇∇∇)	*	
Residual material <input checked="" type="checkbox"/>	With subsequent residual material removal <ul style="list-style-type: none"> • Yes • No 		
CONR	Name to save the updated unmachined-part contour for residual material removal - (only "Yes" for residual material removal)		

Parameter	Description	Unit
Machining <input checked="" type="checkbox"/>	<ul style="list-style-type: none"> • ∇ (roughing) • ∇∇∇ (finishing) • ∇ + ∇∇∇ (roughing and finishing) 	
Machining direction <input checked="" type="checkbox"/>	<ul style="list-style-type: none"> • Face <input checked="" type="checkbox"/> • Longitudinal <input checked="" type="checkbox"/> • Parallel to the contour <input checked="" type="checkbox"/> <div style="display: flex; flex-direction: column; align-items: center;"> <div style="display: flex; align-items: center; margin-bottom: 5px;"> • From inside to outside <div style="border: 1px solid black; padding: 2px 5px;">↑</div> </div> <div style="display: flex; align-items: center; margin-bottom: 5px;"> • From outside to inside <div style="border: 1px solid black; padding: 2px 5px;">↓</div> </div> <div style="display: flex; align-items: center; margin-bottom: 5px;"> • From end face to rear side <div style="border: 1px solid black; padding: 2px 5px;">←</div> </div> <div style="display: flex; align-items: center;"> • From rear side to end face <div style="border: 1px solid black; padding: 2px 5px;">→</div> </div> </div>	
	The machining direction depends on the stock removal direction and choice of tool.	
Position <input checked="" type="checkbox"/>	<ul style="list-style-type: none"> • front • Back • internal • outside 	
D	Maximum depth infeed - (only for ∇)	mm
DX	Maximum depth infeed - (only for parallel to the contour, as an alternative to D)	mm

Parameter	Description	Unit
  	Do not round contour at end of cut. Always round contour at end of cut.	
  	Uniform cut segmentation Round cut segmentation at the edge	
  	Constant cutting depth Alternating cutting depth - (only with align cut segmentation to edge)	
DZ	Maximum depth infeed - (only for position parallel to the contour and UX)	mm
UX or U 	Finishing allowance in X or finishing allowance in X and Z – (only for ∇)	mm
UZ	Finishing allowance in Z – (only for UX)	mm
DI	For zero: Continuous cut - (only for ∇)	mm
BL 	Blank description (only for ∇) <ul style="list-style-type: none"> • Cylinder (described using XD, ZD) • Allowance (XD and ZD on the finished part contour) • Contour (additional CYCLE62 call with blank contour – e.g. cast iron mold) 	
XD	- (only for ∇ machining) - (only for blank description, cylinder and allowance) <ul style="list-style-type: none"> • For blank description, cylinder <ul style="list-style-type: none"> – Version, absolute: Cylinder dimension \varnothing (abs) – Version incremental: Allowance (inc) to maximum values of the CYCLE62 finished part contour • For blank description, allowance <ul style="list-style-type: none"> – Allowance on the CYCLE62 finished part contour (inc) 	mm
ZD	- (only for ∇ machining) - (only for blank description, cylinder and allowance) <ul style="list-style-type: none"> • For blank description, cylinder <ul style="list-style-type: none"> – Version, absolute: Cylinder dimension (abs) – Version incremental: Allowance (inc) to maximum values of the CYCLE62 finished part contour • For blank description, allowance <ul style="list-style-type: none"> – Allowance on the CYCLE62 finished part contour (inc) 	mm

Parameter	Description	Unit
Allowance 	Allowance for pre-finishing - (only for ∇∇∇) <ul style="list-style-type: none"> • Yes U1 contour allowance • No 	
U1	Compensation allowance in X and Z direction (inc) – (only for allowance) <ul style="list-style-type: none"> • Positive value: Compensation allowance is kept • Negative value: Compensation allowance is removed in addition to finishing allowance 	mm
Set machining area limits 	Set machining area limits <ul style="list-style-type: none"> • Yes • No 	
XA XB  ZA ZB 	with limited machining area only, yes: 1. Limit XA ∅ 2. Limit XB ∅ (abs) or 2nd limit referred to XA (inc) 1. Limit ZA 2. Limit ZB (abs) or 2nd limit referred to ZA (inc)	mm
Relief cuts 	Machine relief cuts <ul style="list-style-type: none"> • Yes • No 	
FR	Insertion feedrate, relief cuts	*

* Unit of feedrate as programmed before the cycle call

8.5.8 Stock removal residual (CYCLE952)

8.5.8.1 Function

Function

Using the "Stock removal residual" function, you can remove material that has remained for stock removal along the contour.

During stock removal along the contour, the cycle automatically detects any residual material and generates an updated blank contour. For a G code program, for stock removal residual material, "Yes" must be programmed. Material that remains as part of the finishing allowance is not residual material. Using the "Stock removal residual material" function, you can remove unwanted material with a suitable tool.

The "Stock removal residual material" function is a software option.

Procedure



1. The part program to be executed has been created and you are in the editor.























2. Press the "Turning" and "Contour turning" softkeys.



3. Press the "Stock removal residual material" softkey.
The "Stock removal residual material" input window opens.

Parameters, G code program		
PRG	Name of the program to be generated	
PL 	Machining plane	
RP	Retraction plane – (only for machining direction, longitudinal, inner)	mm
SC	Safety clearance	mm
F	Feedrate	*
CON	Name of the updated blank contour for residual material machining (without the attached character "_C" and double-digit number)	
Residual material 	With subsequent residual material removal <ul style="list-style-type: none"> • Yes • No 	
CONR	Name to save the updated blank contour for residual material removal – (only "Yes" for residual material removal)	

Parameter	Description	Unit		
Machining 	<ul style="list-style-type: none"> • ∇ (roughing) • ∇∇∇ (finishing) 			
Machining direction 	<table border="0"> <tr> <td> <ul style="list-style-type: none"> • Face  • Longitudinal  • Parallel to the contour  </td> <td> <ul style="list-style-type: none"> • From inside to outside • From outside to inside • From end face to rear side • From rear side to end face </td> </tr> </table>	<ul style="list-style-type: none"> • Face  • Longitudinal  • Parallel to the contour  	<ul style="list-style-type: none"> • From inside to outside • From outside to inside • From end face to rear side • From rear side to end face 	
<ul style="list-style-type: none"> • Face  • Longitudinal  • Parallel to the contour  	<ul style="list-style-type: none"> • From inside to outside • From outside to inside • From end face to rear side • From rear side to end face 			
	The machining direction depends on the stock removal direction and choice of tool.			
Position 	<ul style="list-style-type: none"> • front • back • internal • external 			
D	Maximum depth infeed - (only for ∇)	mm		
XDA	1. Grooving limit tool (abs) – (only for face machining direction)	mm		
XDB	2. Grooving limit tool (abs) – (only for face machining direction)	mm		
DX	Maximum depth infeed - (only for parallel to the contour, as an alternative to D)	mm		
	Do not round contour at end of cut. Always round contour at end of cut.			
	Uniform cut segmentation Round cut segmentation at the edge			

Parameter	Description	Unit
	only for align cut segmentation at the edge: Constant cutting depth alternating cutting depth	
Allowance 	Allowance for pre-finishing - (only for ∇∇∇) <ul style="list-style-type: none"> • Yes U1 contour allowance • No 	s
U1	Compensation allowance in X and Z direction (inc) – (only for allowance) <ul style="list-style-type: none"> • Positive value: Compensation allowance is kept • Negative value: Compensation allowance is removed in addition to finishing allowance 	mm
Set machining area limits 	Set machining area limits <ul style="list-style-type: none"> • Yes • No 	
XA XB  ZA ZB 	with limited machining area only, yes: 1. Limit XA ∅ 2. Limit XB ∅ (abs) or 2nd limit referred to XA (inc) 1. Limit ZA 2. Limit ZB (abs) or 2nd limit referred to ZA (inc)	mm
Relief cuts 	Machine relief cuts <ul style="list-style-type: none"> • Yes • No 	
FR	Insertion feedrate, relief cuts	*

* Unit of feedrate as programmed before the cycle call

8.5.9 Grooving (CYCLE952)

8.5.9.1 Function

Function

The "Grooving" function is used to machine grooves of any shape.

Before you program the groove, you must define the groove contour.

If a groove is wider than the active tool, it is machined in several cuts. The tool is moved by a maximum of 80% of the tool width for each groove.

Blank

When grooving, the cycle takes into account a blank that can consist of a cylinder, an allowance on the finished-part contour or any other blank contour.

Precondition

For a G-code program, at least one CYCLE62 is required before CYCLE952.

If CYCLE62 is only present once, then this involves the finished part contour.

If CYCLE62 is present twice, then the first call is the blank contour and the second call is the finished-part contour (also see Chapter "Programming").

Set machining area limits

If, for example, you want to machine a certain area of the contour with a different tool, you can set machining area limits so that machining only takes place in the area of the contour you have selected.

Feedrate interruption

To prevent the occurrence of excessively long chips during machining, you can program a feedrate interruption.

Machining type

You can freely select the machining type (roughing, finishing or complete machining).

For more detailed information, please refer to section "Stock removal".





Procedure





1. The part program to be executed has been created and you are in the editor.
2. Press the "Turning" and "Contour turning" softkeys.
3. Press the "Grooving" softkey.
The "Grooving" input window opens.

Parameter G code program			
PRG	Name of the program to be generated		
PL	Machining plane		
RP	Retraction plane – (only for machining direction, longitudinal, inner)	mm	
SC	Safety clearance	mm	
F	Feed (∇ or ∇∇∇)	*	
FS	Finishing feedrate (only for complete machining: ∇ + ∇∇∇)	*	
Residual material	With subsequent residual material removal		
	<ul style="list-style-type: none"> • Yes • No 		
CONR	Name to save the updated unmachined-part contour for residual material removal - (only "Yes" for residual material removal)		

Parameter	Description	Unit
Machining	<ul style="list-style-type: none"> • ∇ (roughing) • ∇∇∇ (finishing) • ∇ + ∇∇∇ (roughing and finishing) 	
Machining direction	<ul style="list-style-type: none"> • Face • Longitudinal 	
Position	<ul style="list-style-type: none"> • front • Back • internal • outside 	

Parameter	Description	Unit
D	Maximum depth infeed - (only for ∇)	mm
XDA	1. Grooving limit tool (abs) – (only for face machining direction)	mm
XDB	2. Grooving limit tool (abs) – (only for face machining direction)	mm
UX or U 	Finishing allowance in X or finishing allowance in X and Z – (only for ∇)	mm
UZ	Finishing allowance in Z – (only for UX)	mm
DI	For zero: Continuous cut - (only for ∇)	mm
BL 	Blank description (only for ∇) <ul style="list-style-type: none"> • Cylinder (described using XD, ZD) • Allowance (XD and ZD on the finished part contour) • Contour (additional CYCLE62 call with blank contour – e.g. cast iron mold) 	
XD	- (only for ∇ machining) - (only for blank description, cylinder and allowance) <ul style="list-style-type: none"> • For blank description, cylinder <ul style="list-style-type: none"> – Version, absolute: Cylinder dimension \varnothing (abs) – Version incremental: Allowance (inc) to maximum values of the CYCLE62 finished part contour • For blank description, allowance <ul style="list-style-type: none"> – Allowance on the CYCLE62 finished part contour (inc) 	mm
ZD	- (only for ∇ machining) - (only for blank description, cylinder and allowance) <ul style="list-style-type: none"> • For blank description, cylinder <ul style="list-style-type: none"> – Version, absolute: Cylinder dimension (abs) – Version incremental: Allowance (inc) to maximum values of the CYCLE62 finished part contour • For blank description, allowance <ul style="list-style-type: none"> – Allowance on the CYCLE62 finished part contour (inc) 	mm
Allowance 	Allowance for pre-finishing - (only for ∇∇∇) <ul style="list-style-type: none"> • Yes U1 contour allowance • No 	mm
U1	Compensation allowance in X and Z direction (inc) – (only for allowance) <ul style="list-style-type: none"> • Positive value: Compensation allowance is kept • Negative value: Compensation allowance is removed in addition to finishing allowance 	mm
Set machining area limits 	Set machining area limits <ul style="list-style-type: none"> • Yes • No 	

Parameter	Description	Unit
XA	with limited machining area only, yes: 1. Limit XA \varnothing 2. Limit XB \varnothing (abs) or 2nd limit referred to XA (inc)	mm
XB 		
ZA		
ZB 		
N	Number of grooves	
DP	Distance between grooves (inc)	mm

* Unit of feedrate as programmed before the cycle call

8.5.10 Grooving residual material (CYCLE952)

Function

The "Grooving residual material" function is used when you want to machine the material that remained after grooving along the contour.

For a G code program, first select the "Grooving residual material" function. Material that remains as part of the finishing allowance is not residual material. The "Grooving residual material" function allows you to remove unwanted material with a suitable tool.

The "Grooving residual material" function is a software option.



Procedure





1. The part program to be executed has been created and you are in the editor.
2. Press the "Turning" and "Contour turning" softkeys.





3. Press the "Grooving residual material" softkey. The "Grooving residual material" input window is opened.





Parameters, G code program		
PRG	Name of the program to be generated	
PL 	Machining plane	
RP	Retraction plane – (only for longitudinal machining direction)	mm
SC	Safety clearance	mm
F	Feedrate	*
CON	Name of the updated blank contour for residual material machining (without the attached character "_C" and double-digit number)	
Residual material 	With subsequent residual material removal <ul style="list-style-type: none"> • Yes • No 	
CONR	Name to save the updated blank contour for residual material removal – (only "Yes" for residual material removal)	

Parameter	Description	Unit
Machining 	<ul style="list-style-type: none"> • ∇ (roughing) • ∇∇∇ (finishing) 	
Machining direction 	<ul style="list-style-type: none"> • Face • Longitudinal 	
Position 	<ul style="list-style-type: none"> • front • back • internal • external 	
D	Maximum depth infeed - (only for ∇)	mm
XDA	1. Grooving limit tool (abs) – (only for face machining direction)	mm
XDB	2. Grooving limit tool (abs) – (only for face machining direction)	mm
UX or U 	Finishing allowance in X or finishing allowance in X and Z – (only for ∇)	mm
UZ	Finishing allowance in Z – (only for UX)	mm
DI	For zero: Continuous cut - (only for ∇)	mm
Allowance 	Allowance for pre-finishing - (only for ∇∇∇) <ul style="list-style-type: none"> • Yes <ul style="list-style-type: none"> U1 contour allowance • No 	mm

Parameter	Description	Unit
U1	Compensation allowance in X and Z direction (inc) – (only for allowance) <ul style="list-style-type: none"> • Positive value: Compensation allowance is kept • Negative value: Compensation allowance is removed in addition to finishing allowance 	mm
Set machining area limits 	Set machining area limits <ul style="list-style-type: none"> • Yes • No 	
XA XB  ZA ZB 	with limited machining area only, yes: <ol style="list-style-type: none"> 1. Limit XA \emptyset 2. Limit XB \emptyset (abs) or 2nd limit referred to XA (inc) 1. Limit ZA 2. Limit ZB (abs) or (2.) limit referred to ZA (inc) 	mm
N	Number of grooves	
DP	Distance between grooves (inc)	mm

* Unit of feedrate as programmed before the cycle call

8.5.11 Plunge turning (CYCLE952)

Function

Using the "Plunge turning" function, you can machine any shape of groove.

Contrary to grooving, the plunge turning function removes material on the sides after the groove has been machined in order to reduce machining time. Contrary to stock removal, the plunge turning function allows you to machine contours that the tool must enter vertically.

You will need a special tool for plunge turning. Before you program the "Plunge turning" cycle, you must define the contour.

Precondition

For a G-code program, at least one CYCLE62 is required before CYCLE952.

If CYCLE62 is only present once, then this involves the finished part contour.

If CYCLE62 is present twice, then the first call is the blank contour and the second call is the finished-part contour (also see Chapter "Programming").

Set machining area limits

If, for example, you want to machine a certain area of the contour with a different tool, you can set machining area limits so that machining only takes place in the area of the contour you have selected.

Feedrate interruption

To prevent the occurrence of excessively long chips during machining, you can program a feedrate interruption.

Machining type

You can freely select the machining type (roughing, finishing or complete machining).

For more detailed information, please refer to section "Stock removal".

Procedure

1. The part program to be executed has been created and you are in the editor.



2. Press the "Turning" and "Contour turning" softkeys.





3. Press the "Plunge turning" softkey.
The "Plunge turning" input window opens.

Parameters, G code program			
PRG	Name of the program to be generated		
PL	Machining plane		
RP	Retraction plane – (only for longitudinal machining direction)	mm	
SC	Safety clearance	mm	
Residual material 	With subsequent residual material removal		
	<ul style="list-style-type: none"> • Yes • No 		
CONR	Name to save the updated blank contour for residual material removal – ("Yes", only for residual material removal)		

Parameter	Description	Unit
FX	Feedrate in X direction	*
FZ	Feedrate in Z direction	*
FS	Finishing feedrate (only for complete machining: ∇ + ∇∇∇)	*
Machining 	<ul style="list-style-type: none"> • ∇ (roughing) • ∇∇∇ (finishing) • ∇ + ∇∇∇ (roughing and finishing) 	

Parameter	Description	Unit
Machining direction U	<ul style="list-style-type: none"> face longitudinal 	
Position U	<ul style="list-style-type: none"> front back internal external 	
D	Maximum depth infeed - (only for ∇)	mm
XDA	1. Grooving limit tool (abs) – (only for face machining direction)	mm
XDB	2. Grooving limit tool (abs) – (only for face machining direction)	mm
UX or U	Finishing allowance in X or finishing allowance in X and Z – (only for ∇)	mm
UZ	Finishing allowance in Z – (only for UX)	mm
DI	For zero: Continuous cut - (only for ∇)	mm
BL	Blank description (only for ∇) <ul style="list-style-type: none"> Cylinder (described using XD, ZD) Allowance (XD and ZD on the finished part contour) Contour (additional CYCLE62 call with blank contour – e.g. cast iron mold) 	
XD	- (only for ∇ machining) - (only for blank description, cylinder and allowance) <ul style="list-style-type: none"> For blank description, cylinder <ul style="list-style-type: none"> Version, absolute: Cylinder dimension \varnothing (abs) Version incremental: Allowance (inc) to maximum values of the CYCLE62 finished part contour For blank description, allowance <ul style="list-style-type: none"> Allowance on the CYCLE62 finished part contour (inc) 	mm
ZD	- (only for ∇ machining) - (only for blank description, cylinder and allowance) <ul style="list-style-type: none"> For blank description, cylinder <ul style="list-style-type: none"> Version, absolute: Cylinder dimension (abs) Version incremental: Allowance (inc) to maximum values of the CYCLE62 finished part contour For blank description, allowance <ul style="list-style-type: none"> Allowance on the CYCLE62 finished part contour (inc) 	mm
Allowance	Allowance for pre-finishing - (only for ∇∇∇) <ul style="list-style-type: none"> Yes U1 contour allowance No 	mm

U1	Compensation allowance in X and Z direction (inc) – (only for allowance) <ul style="list-style-type: none"> • Positive value: Compensation allowance is kept • Negative value: Compensation allowance is removed in addition to finishing allowance 	mm
----	---	----

Set machining area limits 	Set machining area limits <ul style="list-style-type: none"> • Yes • No 	
XA XB  ZA ZB 	with limited machining area only, yes: <ol style="list-style-type: none"> 1. Limit XA \varnothing 2. Limit XB \varnothing (abs) or 2nd limit referred to XA (inc) <ol style="list-style-type: none"> 1. Limit ZA 2. Limit ZB (abs) or 2nd limit referred to ZA (inc) 	mm
N	Number of grooves	
DP	Distance between grooves	mm

* Unit of feedrate as programmed before the cycle call

8.5.12 Plunge turning residual material (CYCLE952)

Function



The "Plunge turning residual material" function is used when you want to machine the material that remained after plunge turning.

For a G code program, select the function in the screen. Material that remains as part of the finishing allowance is not residual material. The "Plunge turning residual material" function allows you to remove unwanted material with a suitable tool.

The "Plunge turning residual material" function is a software option.



Procedure





1. The part program to be executed has been created and you are in the editor.
2. Press the "Turning" and "Contour turning" softkeys.





3. Press the "Plunge turning residual material" softkey.



The "Plunge turning residual material" input window opens.

Parameters, G code program		
PRG	Name of the program to be generated	
PL 	Machining plane	
RP	Retraction plane – (only for longitudinal machining direction)	mm
SC	Safety clearance	mm
Residual material 	With subsequent residual material removal <ul style="list-style-type: none"> • Yes • No 	
CONR	Name to save the updated blank contour for residual material removal – (only "Yes" for residual material removal)	

Parameter	Description	Unit
FX	Feedrate in X direction	*
FZ	Feedrate in Z direction	*
Machining 	<ul style="list-style-type: none"> • ∇ (roughing) • ∇∇∇ (finishing) 	
Machining direction 	<ul style="list-style-type: none"> • Face • Longitudinal 	
Position 	<ul style="list-style-type: none"> • front • back • internal • external 	
D	Maximum depth infeed - (only for ∇)	mm
UX or U 	Finishing allowance in X or finishing allowance in X and Z – (only for ∇)	mm
UZ	Finishing allowance in Z – (only for UX)	mm
XDA	1. Grooving limit tool Ø (abs) – (end face or rear face only)	mm
XDB	2. Grooving limit tool Ø (abs) – (end face or rear face only)	mm
Allowance 	Allowance for prefinishing <ul style="list-style-type: none"> • Yes <ul style="list-style-type: none"> U1 contour allowance • No 	
DI	For zero: Continuous cut - (only for ∇)	mm

Parameter	Description	Unit
XD	- (only for blank description, cylinder and allowance) <ul style="list-style-type: none"> • For blank description, cylinder <ul style="list-style-type: none"> – Allowance or cylinder dimension \varnothing (abs) – Allowance or cylinder dimension (inc) • For blank description, allowance <ul style="list-style-type: none"> – Allowance on the contour \varnothing (abs) – Allowance on the contour (inc) 	mm
ZD	- (only for blank description, cylinder and allowance) <ul style="list-style-type: none"> • For blank description, cylinder Allowance or cylinder dimension (abs or inc) • For blank description, allowance Allowance on the contour (abs or inc) 	mm
U1	Compensation allowance in X and Z direction (inc) – (only for allowance) <ul style="list-style-type: none"> • Positive value: Compensation allowance is kept • Negative value: Compensation allowance is removed in addition to finishing allowance 	mm
Set machining area limits 	Set machining area limits <ul style="list-style-type: none"> • Yes • No 	
XA XB  ZA ZB 	with limited machining area only, yes: <ol style="list-style-type: none"> 1. Limit XA \varnothing 2. Limit XB \varnothing (abs) or 2nd limit referred to XA (inc) 1. Limit ZA 2. Limit ZB (abs) or (2.) limit referred to ZA (inc) 	mm
N	Number of grooves	
DP	Distance between grooves (inc)	mm

* Unit of feedrate as programmed before the cycle call

8.6 Further cycles and functions

8.6.1 Swivel plane/tool (CYCLE800)

The CYCLE800 swivel cycle is used to swivel to any surface in order to either machine or measure it. In this cycle, the active workpiece zeros and the work offsets are converted to the inclined surface taking into account the kinematic chain of the machine by calling the appropriate NC functions - and rotary axes (optionally) are positioned.

Swiveling can be realized:

- axis by axis
- via solid angle
- via projection angle
- directly

Before the rotary axes are positioned, the linear axes can be retracted if desired.

Swiveling always means three geometry axes.

In the basic version, the following functions

- 3 + 2 axes, inclined machining and
- toolholder with orientation capability

are available.

Setting/aligning tools for a G code program

The swivel function also includes the "Setting tool" and "Aligning milling tool" functions. Contrary to swiveling, when setting and aligning, the coordinate system (WCS) is not rotated at the same time.

Prerequisites before calling the swivel cycle

A tool (tool cutting edge $D > 0$) and the work offset (WO), with which the workpiece was scratched or measured, must be programmed before the swivel cycle is first called in the main program.

Example:

```
N1 T1D1
N2 M6
N3 G17 G54
N4 CYCLE800(1,"",0,57,0,0,0,0,0,0,0,0,0,0,1,0,1)) ;swivel ZERO to
;initial position of the
;machine kinematics
N5 WORKPIECE(,,, "BOX",0,0,50,0,0,0,100,100) ;blank agreement for
;simulation and
;recording
```

For machines where swivel is set-up, each main program with a swivel should start in the basic setting of the machine.

The definition of the blank (WORKPIECE) always refers to the currently effective work offset. For programs that use "swivel", a swivel to zero must be made before the blank is defined. For ShopMill programs, the blank in the program header is automatically referred to the unswiveled state.

In the swivel cycle, the work offset (WO) as well as the shifts and rotations of the parameters of the CYCLE800 are converted to the corresponding machining plane. The work offset is kept. Shifts and rotations are saved in system frames - the swivel frames - (displayed under parameter/work offsets):

- Tool reference (\$P_TOOLFRAME)
- Rotary table reference (\$P_PARTFRAME)
- Workpiece reference (\$P_WPFRAME)

The swivel cycle takes into account the actual machining plane (G17, G18, G19).

Swiveling on a machining or auxiliary surface always involves 3 steps:

- Shifting the WCS before rotation
- Rotating the WCS (axis-by-axis, ...)
- Shifting the WCS after rotation

The shifts and rotations refer to the coordinate system X, Y, Z of the workpiece and are therefore independent of the machine (with the exception of swivel "rotary axis direct").

No programmable frames are used in the swivel cycle. The frames programmed by the user are taken into account for additive swiveling.

On the other hand, when swiveling to a new swivel plane the programmable frames are deleted. Any type of machining operation can be performed on the swivel plane, e.g. by calling standard or measuring cycles.

The last swivel plane remains active after a program reset or when the power fails. The behavior at reset and power on can be set using machine data.



Machine manufacturer

Please refer to the machine manufacturer's specifications.

Block search when swiveling the plane / swiveling the tool

For block search with calculation, after NC start, initially, the automatic rotary axes of the active swivel data set are pre-positioned and then the remaining machine axes are positioned. This does not apply if a type TRACYL or TRANSMIT transformation is active after the block search. In this case, all axes simultaneously move to the accumulated positions.



Machine manufacturer

Please refer to the machine manufacturer's specifications.

Aligning tools

In contrast to "Swivel plane", no rotation is operative in the active frame chain (WCS) in the case of "Swivel tool" or "Align milling tool". Only the offsets calculated by the NC and the corresponding tool orientation are effective.

The maximum angular range for "Align milling tool" is limited by the traversing range of the participating rotary axes.

Name of the swivel data record

Selecting the swivel data set or deselecting the swivel data set.

The selection can be hidden by the machine data.



Machine manufacturer

Please refer to the machine manufacturer's specifications.

Approaching a machining operation

When approaching the programmed machining operation in the swiveled plane, under worst case conditions, the software limit switches could be violated. In this case, the system travels along the software limit switches above the retraction plane. In the event of violation below the retraction plane, for safety reasons, the program is interrupted with an alarm. To avoid this, before swiveling, e.g. move the tool in the X/Y plane and position it as close as possible to the starting point of the machining operation or define the retraction plane closer to the workpiece.

Retraction

Before swiveling the axes you can move the tool to a safe retraction position. The retraction versions available are defined when starting up the system (commissioning).

The retraction mode is modal. When a tool is changed or after a block search, the retraction mode last set is used.



Machine manufacturer

Please refer to the machine manufacturer's specifications.



WARNING

Risk of collision

You must select a retraction position that avoids a collision between the tool and workpiece when swiveling.

Swivel plane (only for G code programming)

- **New**

Previous swivel frames and programmed frames are deleted and a new swivel frame is formed according to the values specified in the input screen.

Every main program must begin with a swivel cycle with the new swivel plane, in order to ensure that a swivel frame from another program is not active.

- **Additive**

The swivel frame is added to the swivel frame from the last swivel cycle.

If several swivel cycles are programmed in a program and programmable frames are also active between them (e.g., AROT ATRANS), these are taken into account in the swivel frame.

If the currently active WO contains rotations, e.g., due to previous workpiece measuring operations, they will be taken into account in the swivel cycle.

Swivel mode

Swiveling can either be realized axis-by-axis, using the angle in space, using the projection angle or directly. The machine manufacturer determines when setting up the "Swivel plane/swivel tool" function which swivel methods are available.



Machine manufacturer

Please refer to the machine manufacturer's specifications.

- **Axis by axis**

In the case of axis-by-axis swiveling, the coordinate system is rotated about each axis in turn, with each rotation starting from the previous rotation. The axis sequence can be freely selected.

- **Solid angle**

With the solid angle swiveling option, the tool is first rotated about the Z axis and then about the Y axis. The second rotation starts from the first.

- **Projection angle**

When swiveling using the projection angle, the angle value of the swiveled surface is projected onto the first two axes of the right-angle coordinate system. The user can freely select the axis rotation sequence.

The 3rd rotation is based on the previous rotation. The active plane and the tool orientation must be taken into consideration when the projection angle is used:

- For G17 projection angle XY, 3rd rotation around Z
- For G18 projection angle ZX, 3rd rotation around Y
- For G19 projection angle YZ, 3rd rotation around X

When projection angles around XY and YX are programmed, the new X-axis of the swiveled coordinate system lies in the old ZX plane.

When projection angles around XZ and ZX are programmed, the new Z-axis of the swiveled coordinate system lies in the old Y-Z plane.

When projection angles around YZ and ZY are programmed, the new Y-axis of the swiveled coordinate system lies in the old X-Y plane.

- **directly**

For direct swiveling, the required positions of the rotary axes are specified. The HMI calculates a suitable new coordinate system based on these values. The tool axis is aligned in the Z direction. You can derive the resulting direction of the X and Y axis by traversing the axes.

Note

Direction of rotation

The positive direction of each rotation for the different swivel versions is shown in the help displays.

Axis sequence

Sequence of the axes which are rotated around:

XYZ or XZY or YXZ or YZX or ZXY or ZYX

Direction (minus/plus)

Direction reference of traversing direction of rotary axis 1 or 2 of the active swivel data set (machine kinematics). The NC calculates two possible solutions of the rotation / offset programmed in CYCLE800 using the angle traversing range of the rotary axes of the machine kinematics. Usually, only one of these solutions is technologically suitable. The solutions differ by 180 degrees in each case. Selecting the "minus" or "plus" direction determines which of the two possible solutions is to be applied.

- "Minus" → Lower rotary axis value
- "Plus" → Higher rotary axis value

Also in the basic setting (pole setting) of the machine kinematics, the NC calculates two solutions and these are approached by CYCLE800. The reference is the rotary axis that was set as direction reference when commissioning the "swivel" function.



Machine manufacturer

Please refer to the machine manufacturer's specifications.

If one of the two positions cannot be reached for mechanical reasons, the alternative position is automatically selected irrespective of the setting of the "Direction" parameter.

Example:

- Machine kinematics with swivel head and swivel table.
 - Swivel head with rotary axis 1 (B) rotates around machine axis Y.
- Angular traversing range of rotary axis B from -90 to +90 degrees.
- Swivel table with rotary axis 2 (C) rotates around machine axis Z.
- Angle traversing range of rotary axis 2 (C) from 0 to 360 degrees (modulo 360).
- Machine manufacturer has set the direction reference to rotary axis 1 (B) when he commissioned the swivel function.
- A rotation around X (WCS) of 10 degrees is programmed in the swivel cycle.

The machine in the basic setting (pole setting) of the kinematics (B = 0 C = 0) is shown in the following diagram.

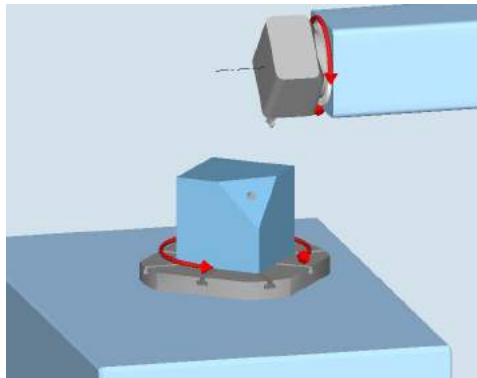

- Direction "-" (minus)
 - Rotary axis B moves to -10 degrees in the negative direction (red arrow).
 - Rotary axis C moves to 90 degrees (rotation around X!).
- Direction "+" (plus)
 - Rotary axis B moves to +10 degrees in the positive direction (red arrow).
 - Rotary axis C moves to 270 degrees.

The two "Minus" or "Plus" direction settings enable a workpiece to be machined with swiveled planes. The two solutions calculated by the NC differ by 180 degrees (see rotary axis C).

Tool

To avoid collisions, you can use the 5-axis transformation (software option) to define the position of the tool tip during swiveling.

- Correct
 - The position of the tool tip is corrected during swiveling (tracking function).
- No correction
 - The position of the tool tip is not corrected during swiveling.



Machine manufacturer

Please refer to the machine manufacturer's specifications.





Procedure



1. The part program or ShopMill program to be processed has been created and you are in the editor.
2. Select the "Miscellaneous" softkey.
3. Press the "Swivel plane" softkey.
The "Swivel plane" input window opens.
4. Press the "Basic setting" softkey if you wish to reestablish the initial state, i.e. you wish to set the values back to 0.
You use this, for example, to swivel the coordinate system back into its original orientation.

Parameters, G code program			Parameters, ShopMill program		
PL 	Machining plane		T	Tool name	
			D	Cutting edge number	
			F 	Feedrate	mm/min mm/rev
			S / V 	Spindle speed or constant cutting rate	rpm m/min

Parameter	Description	Unit
TC 	Name of the swivel data record	
Retraction 	<ul style="list-style-type: none"> • No: No retraction before swiveling • Z: Retraction in the direction of machine axis Z • Z, X, Y: Move machining axis to retraction position before swiveling • Tool direction, max.: Maximum retraction (up to the software end position) in the tool direction • Tool direction, inc.: Retraction, incremental (up to the software end position) in the tool direction <p>When retracting in the tool direction, in the swiveled machine state, several axes can move (travel).</p>	
ZR	Retraction path - (only for incremental retraction in the tool direction)	
Swivel plane 	<ul style="list-style-type: none"> • New: New swivel plane • Additive: Additive swivel plane 	
X0	Reference point for rotation X	
Y0	Reference point for rotation Y	
Z0	Reference point for rotation Z	

Parameter	Description	Unit
Swivel mode 	<ul style="list-style-type: none"> Axis by axis: Rotate coordinate system axis-by-axis Solid angle: Swivel via solid angle Proj. angle: Swiveling via projection angle Direct: Directly position rotary axes 	
Axis sequence 	Sequence of the axes which are rotated around: - (only for axis-by-axis swivel mode) XYZ or XZY or YXZ or YZX or ZXY or ZYX	
X	Rotation around X	- (only for axis sequence)
Y	Rotation around Y	
Z	Rotation around Z	
Projection position 	Position of the projection in space - (only for swivel mode, projection angle) $X\alpha$, $Y\alpha$, $Z\beta$ or $Y\alpha$, $Z\alpha$, $Z\beta$ or $Z\alpha$, $X\alpha$, $Z\beta$	
$X\alpha$	Projection angle	- (only for projection position)
$Y\alpha$	Projection angle	
$Z\beta$	Angle of rotation in the plane	
Name of rotary axis 1	Angle of rotation of rotary axis 1	- (only for direct swivel mode)
Name of rotary axis 2	Angle of rotation of rotary axis 2	
Z	Angle of rotation in the plane	
X1	Zero point of rotated surface X	
Y1	Zero point of rotated surface Y	
Z1	Zero point of rotated surface Z	
Direction 	Direction reference of traversing direction of rotary axis 1 or 2 - (not for direct swivel mode) <ul style="list-style-type: none"> + - 	
Tool 	Tool tip when swiveling <ul style="list-style-type: none"> Correct The position of the tool tip is maintained during swiveling. No correction The position of the tool tip is not maintained during swiveling. 	

Call of an orientation transformation (TRAORI) after swiveling

If a program activating the orientation transformation (TRAORI) is to be executed on the swiveled machining plane, the system frames – tool reference and rotary table reference – for the swivel head or swivel table must be deactivated before TRAORI is called (see example). The workpiece reference (WPFRAME) is retained.

Example (machine with swivel table)

```
N1 G54
N2 T="MILL_10mm"
N3 M6
N4 CYCLE800(1,"",0,57,0,40,0,-45,0,0,0,0,-1) ;Swivel cycle
N5 CYCLE71(50,24,2,0,0,0,80,60,0,4,10,5,0,2000,31,5) ;Face milling
N6 TCARR=0 ;Swivel data set
;deselection
N7 PAROTOF ;Deactivate ;rotary
table reference
N8 TOROTOF ;Deactivate ;tool
reference
; (only for ;swivel head
and ;mixed ;kinematics)
N9 TRAORI ;Activate the
;orientation
;transformation
N10 G54 ;Activate ;work offset
N11 EXTCALL "ROLL" ;Call 5-;axis machining
;program with ;direction
vectors ;(A3, B3, C3)
N12 M2
```

8.6.2 Swiveling tool (CYCLE800)

8.6.2.1 Swiveling tool/preloading milling tools - only for G code program (CYCLE800)

After "Swivel plane", the tool orientation is always perpendicular on the machining plane. When milling with radial cutters, it can make technological sense to set the tool at an angle to the normal surface vector. In the swivel cycle, the setting angle is generated by an axis rotation (max. +/- 90 degrees) to the active swivel plane. When setting, the swivel plane is always "additive". With "Setting tool", only rotations are displayed on the swivel cycle input screen form. The user can freely select the rotation sequence.



Machine manufacturer

Please refer to the machine manufacturer's specifications.

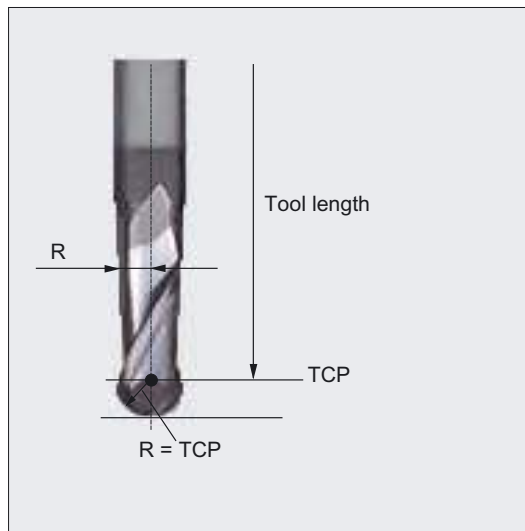

Figure 8-6 The length up to the TCP (Tool Center Point) must be entered as tool length of the radial cutter.

Procedure

1. The part program to be executed has been created and you are in the editor.
2. Press the "Various" softkey.
3. Press the "Swivel tool" and "Setting milling tool" softkeys. The "Setting tool" input window opens.



Parameter	Description	Unit
TC	Name of the swivel data record	
Retraction	<ul style="list-style-type: none"> • No: No retraction before swiveling • Z: Retraction in the direction of machine axis Z • Z, X, Y: Move machining axis to retraction position before swiveling • Tool direction, max.: Maximum retraction in tool direction • Tool direction, inc.: Incremental retraction in tool direction 	
ZR	Retraction path - (only for incremental retraction in the tool direction)	
Axis sequence	Sequence of the axes which are rotated around XY or XZ or YX or YZ or ZX or ZY	
X	Rotation around X	Degrees
Y	Rotation around Y	Degrees
Tool	Tool tip when swiveling <ul style="list-style-type: none"> • Correct The position of the tool tip is maintained during swiveling. • No correction The position of the tool tip is not maintained during swiveling. 	

8.6.2.2 Swiveling aligning tool - only for G code program (CYCLE800)

Function

The purpose of the "Align milling tool" or "Align turning tool" function is to support combined milling machines - lathes with a B axis that can be swiveled.

This functionality is specifically addressing certain configurations of milling machines, which have been expanded by turning functionality. Tool orientation in the turning mode is realized using a swivel axis B (swiveling around Y) with an associated milling spindle (e.g. C1). It is designed to be compatible with both turning and milling tools.

In contrast to "Swivel plane", no rotation is operative in the active zero offsets in the workpiece coordinate system in the case of "Align tool". Only the offsets calculated by the NC and the corresponding tool orientation are effective.

The maximum angular range for "Align tool" is + 360 degrees or it is limited by the traversing range of the participating rotary axes. Technological limits are also placed on the angular range depending on the tool used. When aligning the tool, the data of the tool is calculated based on the tool orientation using the CUTMOD NC command. For a turning tool, this involves the cutting edge position, the holder angle and the cut direction.

The use of the "Align milling tool" function is restricted to milling operations in parallel with the axis (face, peripheral machining) at a machine with a B axis that can be swiveled. If milling is to be possible on any swiveled machining plane, then the "swivel plane" function must be used.





Machine manufacturer

Please refer to the machine manufacturer's specifications.

Procedure



1. The part program to be executed has been created and you are in the editor.
2. Press the "Various" softkey.
3. Press the "Swivel tool" and "Align milling tool" softkeys. The "Align milling tool" input window opens.

Parameter	Description	Unit
TC 	Name of the swivel data record	
Retraction 	<ul style="list-style-type: none"> No: No retraction before swiveling Z: Retraction in the direction of machine axis Z Tool direction, max.: Maximum retraction in tool direction Tool direction, inc.: Incremental retraction in tool direction 	
ZR	Retraction path - (only for incremental retraction in the tool direction)	
β	Rotation around the 3rd geometry axis (for G18 Y)	Degrees
Tool 	Tool tip when swiveling <ul style="list-style-type: none"> Correct The position of the tool tip is maintained during swiveling. No correction The position of the tool tip is not maintained during swiveling. 	

8.6.3 High-speed settings (CYCLE832)

Function

With the "High Speed Settings" function (CYCLE832), data for the machining of free-form surfaces is pre-assigned values so that optimum machining is possible.

The call of CYCLE832 contains three parameters:

- Tolerance
- Machining type (technology)
- Input of the orientation tolerance (for 5-axis machines)

Machining of free-form surfaces involves high requirements regarding velocity, precision and surface quality.

You can achieve optimum velocity control depending on the type of machining (roughing, rough-finishing, finishing) very simply with the "High Speed Settings" cycle.

Program the cycle in the technology program before the geometry program is called.

The "High Speed Settings" cycle is also in conjunction with the "Advanced Surface" function.



Software option

You require the software option in order to use this function:
"Advanced Surface"

Machining methods

With the "High Speed Settings" function, you can select between four technological machining types:

- "Finishing"
- "Rough-finishing"
- "Roughing"
- "Deselected" (default setting)

Note

Plain text entry

You can enter the parameters in plain text in the "Machining" selection box.

Plain text is generated for the "Machining mode" parameter when the input screen is closed.

For CAM programs in the HSC range, the four machining types directly relate to the accuracy and speed of the path contour (see help screen).

The operator/programmer uses the tolerance value to give a corresponding weighting.

Corresponding to the appropriate G commands, the four machining types are assigned to technology G group 59:

Machining type	Technology G group 59
Deselection	DYNNORM
Finishing	DYNFINISH
Rough-finishing	DYNSEMIFIN
Roughing	DYNROUGH

Orientation tolerance

You can enter the orientation tolerance for applications on machines with the dynamic multi-axis orientation transformation (TRAORI).

MD note

Additional G commands that are available in conjunction with machining free-form surfaces, are also activated in the High Speed Settings cycle.

When deselecting CYCLE832, the G groups are programmed to the settings - during the program run time - that are declared in the machine data for the reset state.

Display of important information

In the "Machine" operating area, you have the option of displaying important HSC information.

References

For additional information, please refer to the following documentation:

Commissioning Manual SINUMERIK Operate / SINUMERIK 840D sl



Machine manufacturer

Please refer to the machine manufacturer's specifications.

Procedure



1. The part program or ShopMill program to be processed has been created and you are in the editor.
2. Press the "Various" softkey.
3. Press the "High Speed Settings" softkey.
The "High Speed Settings" input window is opened.

Parameter	Description	Unit
Machining 	<ul style="list-style-type: none"> • ▽ (roughing) Plain text: _ROUGH • ▽▽ (semi-finishing) Plain text: _SEMIFIN • ▽▽▽ (finishing) Plain text entry: _FINISH • Deselection Plain text entry: _OFF 	
	<p>For "Multi-axis programming yes", the following plain texts are generated in accordance with the machining type:</p> <ul style="list-style-type: none"> • ▽ (roughing) with input of the orientation tolerance Plain text: _ORI_ROUGH • ▽▽ (semi-finishing) with input of the orientation tolerance Plain text entry: _ORI_SEMIFIN • ▽▽▽ (finishing) with input of the orientation tolerance Plain text entry: _ORI_FINISH 	

Parameter	Description	Unit
Tolerance	Tolerance of the machining axis	
Multi-axis program 	<p>Multi-axis program for 5-axis machines</p> <ul style="list-style-type: none"> • Yes The orientation tolerance >0 degrees can be entered here • No The value 1 is entered automatically <p>Note The field can be hidden. Please observe the machine manufacturer's instructions.</p>	

8.6.4 Subroutines

If you require the same machining steps when programming different workpieces, you can define these machining steps in a separate subprogram. You can then call this subprogram in any programs.

Identical machining steps therefore only have to be programmed once.

ShopMill does not differentiate between main programs and subprograms. This means that you can call a "standard" machining step or G code program as subprogram in another machining step program.

You can also call another subprogram in the subprogram. The maximum nesting depth is 8 subprograms.

You cannot insert subprograms into linked blocks.

If you want to call machining step program as subprogram, the program must already have been calculated once (load or simulate program in Machine Auto mode). This is not necessary for G code subprograms.

The subprogram must always be stored in the NCK work memory (in a separate directory "XYZ" or in the "ShopMill", "Part programs", "Subprograms" directories).

If you want to call a subprogram located on another drive, you can use G code command "EXTCALL".

Please note that, when a subprogram is called, ShopMill evaluates the settings in the program header of the subprogram. These settings also remain active even after the subprogram has ended.

If you wish to activate the settings from the program header for the main program again, you can make the settings again in the main program after calling the subprogram.

Procedure

1. Generate a ShopMill or G code program that you wish to call as a subprogram in another program.
2. Position the cursor in the work plan or in the program view of the main program on the program block after which you wish to call the subprogram.
3. Press the "Various" and "Subroutine" softkeys.

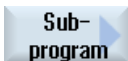

4. Enter the path of the subprogram if the desired subprogram is not stored in the same directory as the main program.
The subprogram is thus executed in the position pattern.



5. Press the "Accept" softkey.
The subprogram call is inserted in the main program.

Parameter	Description
Path/workpiece	Path of the subprogram if the desired subprogram is not stored in the same directory as the main program.
Program name	Name of the subprogram that is to be inserted.

Programming example

```

N10 T1 D1                ;Load tool
N11 M6
N20 G54 G710            ;Select work offset
N30 M3 S12000           ;Switch-on spindle
N40 CYCLE832(0.05,3,1)   ;Tolerance value 0.05 mm, machining type,
                        ;roughing
N50 EXTCALL"CAM_SCHRUPP" Externally call subprogram CAM_SCHRUPP
N60 T2 D1                ;Load tool
N61 M6
N70 CYCLE832(0.005,1,1) ;Tolerance value 0.005 mm, machining
                        ;type, finishing
N80 EXTCALL"CAM_SCHLICHT" ;Call subprogram CAM_SCHLICHT
N90 M30                 ;End of program
    
```

The subprograms CAM_SCHRUPP.SPF, CAM_SCHLICHT.SPF contain the workpiece geometry and the technological values (feedrates). These are externally called due to the program size.

8.7 Additional cycles and functions in ShopMill

8.7.1 Transformations

To make programming easier, you can transform the coordinate system. Use this possibility, for example, to rotate the coordinate system.

Coordinate transformations only apply in the actual program. You can define shift, rotation, scaling or mirroring. You can select between a new or an additive coordinate transformation.

In the case of a new coordinate transformation, all previously defined coordinate transformations are deselected. An additive coordinate transformation acts in addition to the currently selected coordinate transformations.

Note

Transformations with virtual axes

Please note that when selecting TRANSMIT or TRACYL offsets, scaling and mirroring, the real Y axis is not transferred into the virtual Y axis.

Offsets, scalings and mirroring of the virtual Y axis are deleted for TRAFOOF.

Procedure for work offset, offset, rotation, scaling or mirroring



1. The ShopMill program has been created and you are in the editor.
2. Press the "Various" and "Transformation" softkeys.

3. Press the "Work offsets" softkey.
The "Work offsets" input window opens.

- OR -

Press the "Offset" softkey.

The "Offset" input window opens.

- OR -

Press the "Rotation" softkey.

The "Rotate" input window opens.

- OR -

Press the "Scaling" softkey.

The "Scaling" input window opens.



- OR -
 Press the "Mirroring" softkey.
 The "Mirroring" input window opens.

8.7.2 Translation

For each axis, you can program an offset of the zero point.

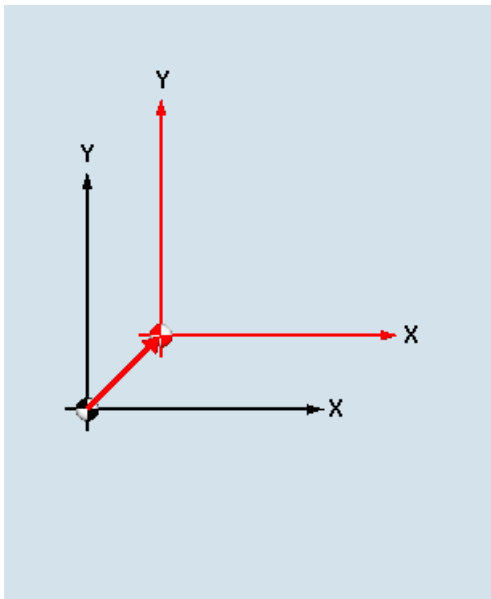

New offset

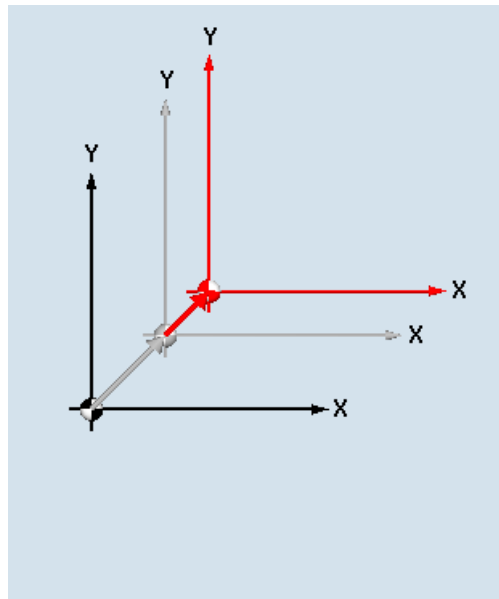

Additive offset

Parameter	Description	Unit
Offset 	<ul style="list-style-type: none"> New New offset Additive Additive offset 	
X	Offset X	mm
Y	Offset Y	mm
Z	Offset Z	mm

8.7.3 Rotation

You can rotate every axis through a specific angle. A positive angle corresponds to counterclockwise rotation.

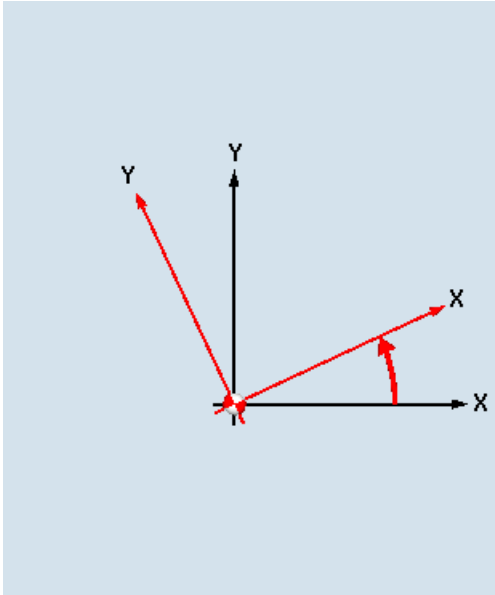

New rotation

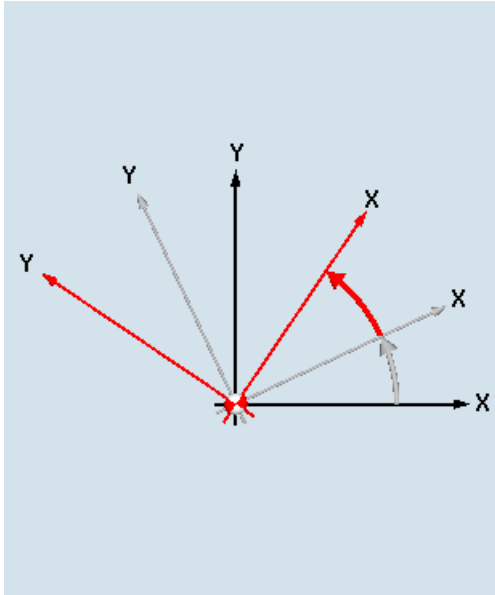

Additive rotation

Parameter	Description	Unit
Rotation	<ul style="list-style-type: none"> • New New rotation • Additive Additive rotation 	
X	Rotation around X	Degrees
Y	Rotation around Y	Degrees
Z	Rotation around Z	Degrees

8.7.4 Scaling

You can specify a scale factor for the active machining plane as well as for the tool axis. The programmed coordinates are then multiplied by this factor.

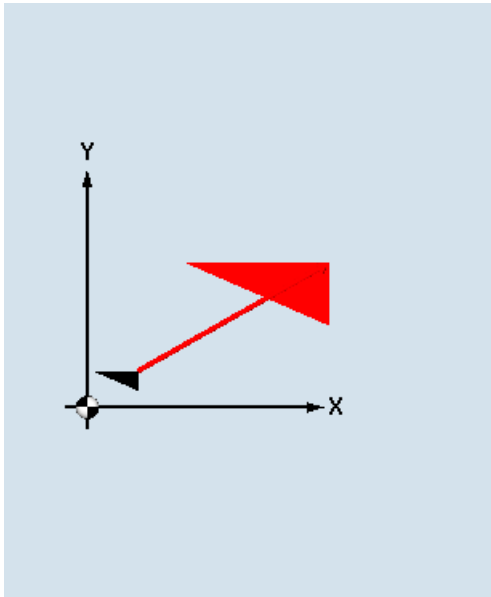

New scaling

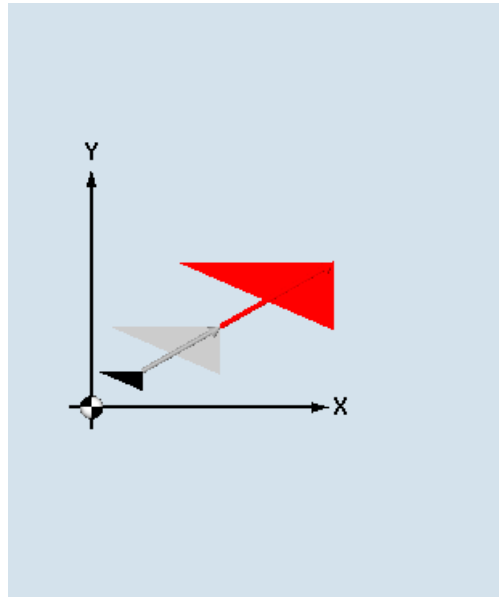

Additive scaling

Parameter	Description	Unit
Scaling 	<ul style="list-style-type: none"> New New scaling Additive Additive scaling 	
XY	Scale factor XY	
Z	Scale factor Z	

8.7.5 Mirroring

Furthermore, you can mirror all axes. Enter the axis to be mirrored in each case.

Note

Travel direction of the milling cutter



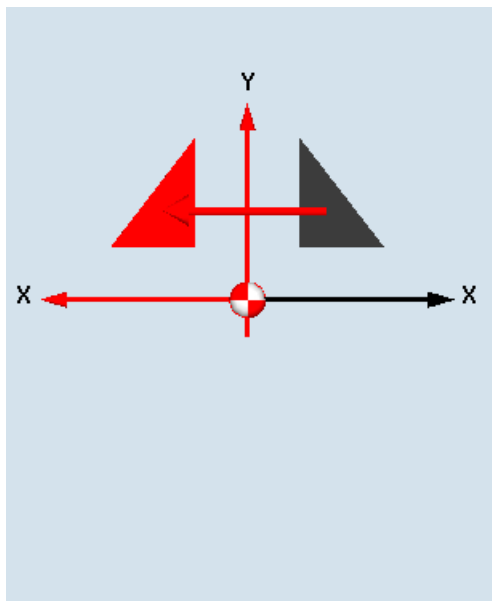

Note that with mirroring, the travel direction of the cutting tool (conventional/climbing) is also mirrored.

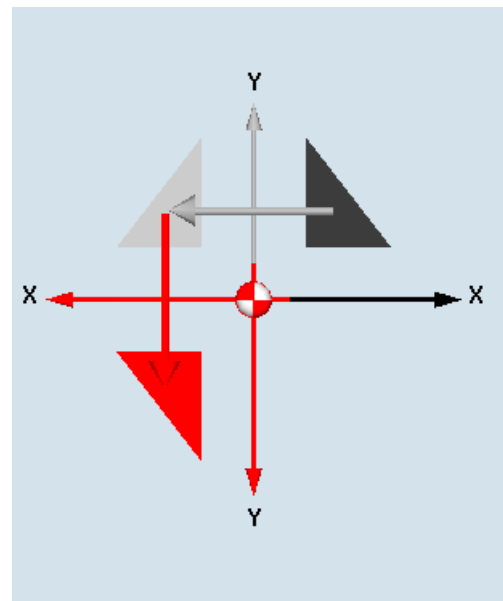

New mirroring



Additive mirroring

Parameter	Description	Unit
Mirroring 	<ul style="list-style-type: none"> New New mirroring Additive Additive mirroring 	
X 	Mirroring of the X axis, on/off	
Y 	Mirroring of the Y axis, on/off	
Z 	Mirroring of the Z axis, on/off	

8.7.6 Cylinder surface transformation

You require the cylinder surface transformation to machine

- Longitudinal grooves on cylindrical bodies,
- Transverse grooves on cylindrical objects
- grooves with any path on cylindrical bodies.

The path of the grooves is programmed with reference to the unwrapped, level surface of the cylinder. The groove can be programmed using line/circle, drilling or milling cycles or with contour milling (free contour programming).

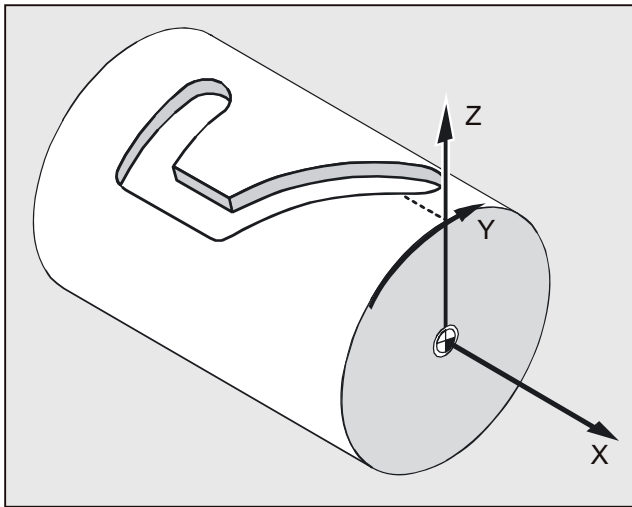

Supporting several data sets

- If several Tracyl data sets have been set up, then the corresponding rotary axes can be selected.
- If several Tracyl data sets have been set up around a rotary axis, then the corresponding numbers of the data sets can be selected.

Slot side compensation

Cylinder surface transformation is available in the following versions:

Slot side compensation off

When slot side compensation is deactivated, any type of slot with parallel sides can be machined if the tool diameter is equal to the slot width.

The slot sides are not parallel if the slot width is larger than the tool diameter.

The slot contour is programmed for machining purposes.

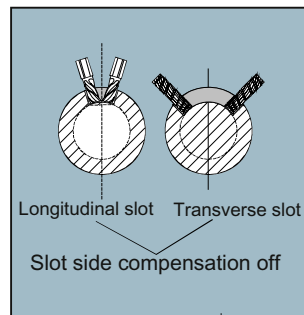

Slot side compensation on

This function is only permissible during path milling with switched-on radius compensation.

When slot side compensation is on, slots with parallel sides are machined even if the slot width is larger than the tool diameter.

The slot contour must not be programmed for machining purposes, but the imaginary center-point path of a bolt guided in the slot; whereby the bolt must move along every side. The slot width is determined by parameter D.

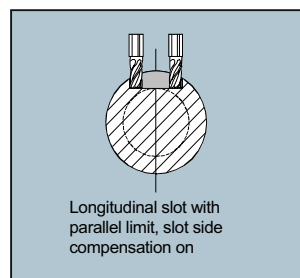

Note

Selecting slot side compensation

The slot side compensation selection depends on the transformation type.

8.7.6.1 General programming

The basic programming procedure is as follows:

1. Select work offset for cylinder surface transformation (e.g. offset the zero point on the center point of the cylinder end face)
2. Position the Y axis (Y axis must be positioned prior to cylinder surface transformation because it is defined differently after transformation)
3. Activate cylinder surface transformation
4. Select work offset for machining on the developed cylinder surface (e.g. shift zero point to the zero point on the workpiece drawing)

5. Program machining operation (e.g. enter contour and path milling)
6. Deactivate cylinder surface transformation

The programmed cylinder surface transformation is simulated only as developed peripheral surface.

Note

The work offsets active prior to selection of cylinder surface transformation are no longer active after the function has been deselected.

1. The ShopMill program to be edited has been created and you are in the editor.
2. Press the "Various" softkey.

3. Press the "Transformations" and "Cylinder surface" softkeys.







Table 8- 1

Parameters	Description	Unit
Cylinder surface trans. 	<ul style="list-style-type: none"> • Yes Activates the cylinder surface transformation for programming. For several rotary axes, instead of "yes", the name of the rotary axis (A or B) is displayed. • No Deactivates cylinder surface transformation after programming. 	
Transformation number	Selects the Tracyl data set, if there are several Tracyl data sets.	
∅	Cylinder diameter - only for "Cylinder surface transformation yes"	
Slot side compensation 	<ul style="list-style-type: none"> • on - only for "Cylinder surface transformation yes" Activates slot side compensation. • off - only for "Cylinder surface transformation yes" Deactivates slot side compensation. The selection for "slot side compensation" depends on the transformation type.	
D	Offset to programmed path - only for "slot side compensation on"	

8.7.7 Straight or circular machining

When you want to perform straight or circular path movements or machining without defining a complete contour, you can use the functions "Straight line" or "Circle" respectively.

General sequence

To program simple machining operations, proceed as follows:

- Specify the tool and the spindle speed
- Program the machining operation

Machining options

The following machining options are available:

- Straight line
- Circle with known center point
- Circle with known radius
- Helix
- Straight line with polar coordinates
- Circle with polar coordinates

If you want to program a straight line or a circle using polar coordinates, you must define the pole first.

 CAUTION
--

If you use a straight or circular path movement to move the tool into the retraction zone specified in the program header, you must also move the tool out again. Otherwise a collision could occur as a result of the traversing movements in a subsequently programmed cycle.

Before you can program a straight line or circle, you have to select the tool, spindle speed and machining plane.

If you program a sequence of different straight or circular path movements, the settings for the tool and spindle speed remain active until you change these again.

Procedure



1. The ShopMill program to be edited has been created and you are in the editor.



2. Press the menu forward key and the "Straight Circle" softkey.



3. Press the "Tool" softkey.
The parameter screen "Tool" is opened.

4. Enter a tool in parameter field "T".
- OR -



Press the "Select tool" softkey.
The "Tool selection" window is opened.



Position the cursor on the tool that you wish to use for machining and press the "To program" softkey.

The tool is copied into the "T" parameter field.

- OR -

Press the "Tool list" and "New tool" softkeys.

Using the softkeys on the vertical softkey bar, select the required tool and press the "To program" softkey.

The tool is copied into the "T" parameter field.

5. Select the tool cutting edge number D if the tool has several cutting edges.



6. Enter the spindle speed or cutting rate.

7. Enter an allowance in the "DR" field.



Press the "Accept" softkey.

The values are saved and the parameterization screen form is closed.
The process plan is displayed and the newly generated program block is marked.

Parameter	Description	Unit
T	Tool name	
D 	Cutting edge number	
S / V 	Spindle speed or Constant cutting rate	rev/min m/min
DR	Allowance, tool radius	mm

8.7.8 Programming a straight line

The tool moves at the programmed feedrate or with rapid traverse from its actual position to the programmed end position.

Radius compensation

Alternatively, you can implement the straight line with radius compensation. The radius compensation acts modally, therefore you must deactivate the radius compensation again when you want to traverse without radius compensation. Where several straight line blocks with radius compensation are programmed sequentially, you may only select radius compensation in the first program block.

When executing the first path motion with radius compensation, the tool traverses without compensation at the starting point and with compensation at the end point. This means that if a vertical path is programmed, the tool traverses an oblique path. The compensation is not applied over the entire traversing path until the second programmed path motion with radius compensation is executed. The reverse effect occurs when radius compensation is deactivated.

Procedure

1. The ShopMill program to be edited has been created and you are in the editor.



2. Press the menu forward key and the "Straight Circle" softkey.











3. Press the "Straight line" softkey.



4. Press the "Rapid traverse" softkey to enter the feedrate in rapid traverse.



Parameter	Description	Unit
X 	Target position X (abs) or target position X referred to the last programmed position (inc)	mm
Y 	Target position Y (abs) or target position Y referred to the last programmed position (inc)	mm
Z 	Target position Z (abs) or target position Z referred to the last programmed position (inc)	mm
	Note Incremental dimensions: The sign is also evaluated.	
F 	Machining feedrate	mm/rev mm/min mm/tooth
Radius compensation	Input defining which side of the contour the cutter travels in the programmed direction:	
	 Radius compensation to right of contour	
	 Radius compensation to left of contour	
	 Radius compensation off	
	 The previously programmed setting for radius compensation is used.	

8.7.9 Programming a circle with known center point

The tool travels along a circular path from its actual position to the programmed circle end point. You must know the position of the circle center point. The control calculates the radius of the circle/arc on the basis of your interpolation parameter settings.







The circle can only be traversed at machining feedrate. You must program a tool before the circle can be traversed.

Procedure

1. The ShopMill program to be edited has been created and you are in the editor.
2. Press the menu forward key and the "Straight Circle" softkey.



3. Press the "Circle center point" softkey.

Parameter	Description	Unit
Direction of rotation 	The tool travels in the programmed direction from the circle starting point to its end point. You can program this direction as clockwise or counter-clockwise.	
	 Clockwise direction of rotation	
	 Counter-clockwise direction of rotation	
X 	Target position X (abs) or target position X referred to the last programmed position (inc)	mm
Y 	Target position Y (abs) or target position Y referred to the last programmed position (inc)	mm
I	Distance between circle starting point and center point in X direction (inc.)	mm
J	Distance between circle starting point and center point in Y direction (inc.)	mm
F 	Machining feedrate	mm/rev mm/min mm/tooth
PL	Plane: The circle is traversed in the set plane with the relevant interpolation parameters: XYIJ: XY plane with interpolation parameters I and J ZXKI: ZX plane with interpolation parameters K and I YZJK: YZ plane with interpolation parameters J and K	mm mm mm

8.7.10 Programming a circle with known radius

The tool traverses a circular path with the programmed radius from its actual position to the programmed circle end point. The control system calculates the circle center point. You do not need to program interpolation parameters.

The circle can only be traversed at machining feedrate.





Procedure

1. The ShopMill program to be edited has been created and you are in the editor.
2. Press the menu forward key and the "Straight Circle" softkey.



3. Press the "Circle radius" softkey.



Parameter	Description	Unit
Direction of rotation 	The tool travels in the programmed direction from the circle starting point to its end point. You can program this direction as clockwise or counter-clockwise.	
	 Clockwise direction of rotation	
	 Counter-clockwise direction of rotation	
X 	Target position X (abs) or target position X referred to the last programmed position (inc)	mm
Y 	Target position Y (abs) or target position Y referred to the last programmed position (inc)	mm
R	Radius of arc. You can select the arc of your choice by entering a positive or a negative sign.	mm
F	Machining feedrate	mm/rev mm/min mm/tooth

8.7.11 Helix

With helical interpolation, a circular movement is overlaid in the plane with a linear motion in the tool axis, i.e. a spiral is created.



Procedure

1. The ShopMill program to be edited has been created and you are in the editor.
2. Press the menu forward key and the "Straight Circle" softkey.



3. Press the "Helix" softkey.



Parameter	Description	Unit
Direction of rotation 	The tool travels in the programmed direction from the circle starting point to its end point. You can program this direction as clockwise or counterclockwise.	
	 Clockwise direction of rotation	
	 Counterclockwise direction of rotation	

Parameter	Description	Unit
I	Center point of the helix in the X direction (abs or inc)	mm
J	Center point of the helix in the Y direction (abs or inc)	mm
P	Helix pitch The pitch is programmed in mm per revolution.	mm/rev
Z	Target position of the helical end point (abs or inc)	mm
 F	Machining feedrate	mm/rev mm/min mm/tooth

8.7.12 Polar coordinates

If a workpiece has been dimensioned from a central point (pole) with radius and angles, you will find it helpful to program these as polar coordinates.

You can program straight lines and circles as polar coordinates.

Defining a pole

You must define the pole before you can program a straight line or circle in polar coordinates. This pole acts as the reference point of the polar coordinate system.

The angle for the first line or circle then needs to be programmed in absolute coordinates. You can program the angles for any additional straight lines and circles as either absolute or incremental coordinates.



Procedure

1. The ShopMill program to be edited has been created and you are in the editor.
2. Press the menu forward key and the "Polar" softkey.



3. Press the "Pole" softkey.



Parameter	Description	Unit
X 	Pole X (abs) or pole X referred to the last programmed position (inc)	mm
Y 	Pole Y (abs) or pole Y referred to the last programmed position (inc)	mm

8.7.13 Straight polar

A straight line in the polar coordinate system is defined by a radius (L) and an angle (α). The angle refers to the X axis.

The tool moves from its actual position along a straight line to the programmed end point at the machining feedrate or in rapid traverse.

The 1st straight line in polar coordinates entered after the pole must be programmed with an absolute angle. You can program any additional straight lines or circles with incremental coordinates.

Procedure

1. The ShopMill program to be edited has been created and you are in the editor.
2. Press the menu forward key and the "Straight Circle" softkey.





>

3. Press the "Polar" and "Straight polar" softkeys.

Polar

Straight polar
4. Press the "Rapid traverse" softkey to enter the feedrate in rapid traverse.

Rapid

Parameter	Description	Unit
L	Distance to the pole, end point	mm
α 	Polar angle to the pole, end point (abs) or change in polar angle to the pole, end point (inc)	Degrees
F	Machining feedrate	mm/rev mm/min mm/tooth
Radius compensation	Input defining which side of the contour the cutter travels in the programmed direction:	
	 Radius compensation to left of contour	
	 Radius compensation to right of contour	
	 Radius compensation off	
	 The set radius compensation remains as previously set	

8.7.14 Circle polar

A circle in the polar coordinate system is defined by an angle (α). The angle refers to the X axis.

The tool moves from its actual position on a circular path to the programmed end point (angle) at the machining feedrate. The radius corresponds to the distance from the actual tool position to the defined pole, i.e. the circle starting and end point positions are at the same distance from the defined pole.

The 1st arc in polar coordinates entered after the pole must be programmed with an absolute angle. You can program any additional straight lines or circles with incremental coordinates.



Procedure

1. The ShopMill program to be edited has been created and you are in the editor.
2. Press the menu forward key and the "Straight Circle" softkey.



3. Press the "Polar" and "Circle polar" softkeys.



Parameter	Description	Unit
Direction of rotation	The tool travels in the programmed direction from the circle starting point to its end point. You can program this direction as clockwise (right) or counter-clockwise (left).	
	 Clockwise direction of rotation	
	 Counter-clockwise direction of rotation	
	Polar angle to the pole, end point (abs) or change in polar angle to the pole, end point (inc)	Degrees
F	Machining feedrate	mm/rev mm/min mm/tooth



8.7.15 Obstacle

Function

If there is an obstacle between 2 position patterns, it can be crossed. The height of the obstacle is programmed in absolute terms.

If all positions in the 1st pattern have been machined, the tool axis travels with rapid traverse to a height corresponding to the obstacle height + safety clearance. The new position is approached with rapid traverse at this height. The tool axis then approaches a position according to Z0 of the position pattern + safety clearance with rapid traverse.

Procedure

1. The ShopMill program to be edited has been created and you are in the editor.
2. Press the "Drilling" softkey.

3. Press the "Positions" and "Obstacle" softkeys.

The "obstacle" input window opens.

Note

Obstacles are only taken into consideration if they lie between 2 position patterns. If the tool change point and the programmed retraction plane are positioned below the obstacle, the tool travels to the retraction plane height and on to the new position without taking the obstacle into account. The obstacle must not be higher than the retraction plane.

Parameter	Description	Unit
Z0 	Obstacle height (abs)	

Multi-channel view (only 840D sl)

9.1 Multi-channel view

The multi-channel view allows you to simultaneously view several channels in the following operating areas:

- "Machine" operating area
- "Program" operating area

See also

Editor settings (Page 181)

9.2 Multi-channel view in the "Machine" operating area

With a multi-channel machine, you have the option of simultaneously monitoring and influencing the execution of several programs.



Machine manufacturer

Please refer to the machine manufacturer's specifications.

Displaying the channels in the "Machine" operating area

In the "Machine" operating area, you can display 2 - 4 channels simultaneously.

Using the appropriate settings, you can define the sequence in which channels are displayed. Here, you can also select if you wish to hide a channel.

Note

The "REF POINT" operating mode is shown only in the single-channel view.

Multi-channel view

2 - 4 channels are simultaneously displayed in channel columns on the user interface.

- Two windows are displayed one above the other for each channel.
- The actual value display is always in the upper window.
- The same window is displayed for both channels in the lower window.
- You can select the display in the lower window using the vertical softkey bar.

The following exceptions apply when making a selection using the vertical softkeys:

- The "Actual values MCS" softkey switches over the coordinate systems of both channels.
- The "Zoom actual value" and "All G functions" softkeys switch into the single-channel view.

Single-channel view

If, for your multi-channel machine, you always only wish to monitor one channel, then you can set a permanent single-channel view.

Horizontal softkeys

- Block search

When selecting the block search, the multi-channel view is kept. The block display is displayed as search window.

- Program control

The "Program Control" window is displayed for the channels configured in the multi-channel view. The data entered here applies for these channels together.

- If you press an additional horizontal softkey in the "Machine" operating area (e.g. "Overstore", "Synchronized actions"), then you change into a temporary single-channel view. If you close the window again, then you return to the multi-channel view.

Switching between single- and multi-channel view



Press the <MACHINE> key in order to briefly switch between the single- and multi-channel view in the machine area.



Press the <NEXT WINDOW> key in order to switch between the upper and lower window within a channel column.

Editing a program in the block display



You can perform simple editing operations as usual with the <INSERT> key in the actual block display.

If there is not sufficient space, you switch over into the single-channel view.

Running-in a program

You select individual channels to run-in the program at the machine.

Requirement

- Several channels have been set-up.
- The setting "2 channels", "3 channels" or "4 channels" is selected.

Displaying/hiding a multi-channel view



1. Select the "Machine" operating area



2. Select the "JOG", "MDA" or "AUTO" mode.

...



3. Press the menu forward key and the "Settings" softkey.



4. Press the "Multi-channel view" softkey.



5. In the window "Settings for Multi-Channel View" in the selection box "View", select the required entry (e.g. "2 channels") and define the channels as well as the sequence in which they are to be displayed.

In the basic screen for the "AUTO", "MDA" and JOG" operating modes, the upper window of the left-hand and right-hand channel columns are occupied by the actual value window.

6. Press the "T,F,S" softkey if you wish to view the "T,F,S" window. The "T,F,S" window is displayed in the lower window of the left-hand and right-hand channel column.



Note:

The "T,F,S" softkey is present only for smaller operator panels, i.e. up to OP012.

9.3 Multi-channel view for large operator panels

On the OP015 and OP019 operator panels as well as on the PC, you have the option of displaying up to four channels next to each one. This simplifies the creation and run-in for multi-channel programs.

Constraints

- OP015 with a resolution of 1024x768 pixels: up to three channels visible
- OP019 with a resolution of 1280x1024 pixels: up to four channels visible
- The operation of a OP019 requires a PCU50.5

3- or 4-channel view in the "Machine" operating area

Use the multi-channel view settings to select the channels and specify the view.

Channel view	Display in the "Machine" operating area
3-channel view	<p>The following windows are displayed one above the other for each channel:</p> <ul style="list-style-type: none">• Actual Value window• T,F,S window• Block Display window <p>Selecting functions</p> <ul style="list-style-type: none">• The T,F,S window is overlaid by pressing one of the vertical softkeys.
4-channel view	<p>The following windows are displayed one above the other for each channel:</p> <ul style="list-style-type: none">• Actual Value window• G functions (the "G functions" softkey is omitted). "All G functions" is accessed with the Menu forward key.• T,S,F window• Block Display window <p>Selecting functions</p> <ul style="list-style-type: none">• The window showing the G codes is overlaid if you press one of the vertical softkeys.

Toggling between the channels



Press the <CHANNEL> key to toggle between the channels.



Press the <NEXT WINDOW> key to toggle within a channel column between the three or four windows arranged one above the other.

Note

2-channel display

Unlike the smaller operator panels, the T,F,S window is visible for a 2-channel view in the "Machine" operating area.

Program operating area

You can display as many as ten programs next to each other in the editor.

Displaying a program

You can define the width of the program in the Editor window using the settings in the editor. This means that you can distribute programs evenly - or you can widen the column with the active program .

Channel status

When required, channel messages are displayed in the status display.



Machine manufacturer

Please refer to the machine manufacturer's specifications.

9.4 Setting the multi-channel view

Setting	Meaning
View	Here, you specify how many channels are displayed. <ul style="list-style-type: none">• 1 channel• 2 channels• 3 channels• 4 channels
Channel selection and sequence (for "2 - 4 channels" view)	You specify which channels in which sequence are displayed in the multi-channel view.
Visible (for "2 - 4 channels" view)	Here, you specify which channels are displayed in the multi-channel view. You can quickly hide channels from the view.

Example

Your machine has 6 channels.

You configure channels 1 - 4 for the multi-channel view and define the display sequence (e.g. 1,3,4,2).

In the multi-channel view, for a channel switchover, you can only switch between the channels configured for the multi-channel view; all others are not taken into consideration. Using the <CHANNEL> key, advance the channel in the "Machine" operating area - you obtain the following views: Channels "1" and "3", channels "3" and "4", channels "4" and "2". Channels "5" and "6" are not displayed in the multi-channel view.

In the single-channel view, toggle between all of the channels (1...6) without taking into account the configured sequence for the multi-channel view.

Using the channel menu, you can always select all channels, also those not configured for multi-channel view. If you switch to another channel, which is not configured for the multi-channel view, then the system automatically switches into the single-channel view. There is no automatic switchback into the multi-channel view, even if a channel is again selected, which has been configured for multi-channel view.

Procedure



1. Select the "Machine" operating area.



2. Select the "JOG", "MDA" or "AUTO" mode.



3. Press the menu forward key and the "Settings" softkey.



4. Press the "Multi-channel view" softkey.
The "Settings for Multi-Channel View" window is opened.



5. Set the multi-channel or single-channel view and define which channels are to be seen in the "Machine" operating area - and in the editor - in which sequence.

Collision avoidance (only 840D sl)

10.1 Collision monitoring in the machine operator area:

With the aid of collision avoidance, you can avoid collisions and therefore major damage during the machining of a workpiece or when creating programs.



Software option

You require the software option in order to use this function: "Collision avoidance (machine, operating range)"



Machine manufacturer

Please refer to the machine manufacturer's specifications.

The collision avoidance is based on a machine model. The kinematics of the machine are described as a kinematic chain, to which different protection areas for machine parts and tools are assigned. With the help of collision pairs, two protection areas are monitored for collision.

The "Collision avoidance" function regularly calculates the clearance of these protection areas during machining. When two protection areas approach one another, and a specific safety clearance is reached, an alarm is displayed and the program before the corresponding traversing block is stopped and/or the traversing motion is stopped.

Precondition

- The collision avoidance has been set up and a active machine model is available.
- The setting "Collision avoidance" has been selected for the operation mode AUTO or for the operation modes JOG and MDA.

Procedure



1. Select the "Machine" operating area



2. Press the <AUTO> key.

10.2 Switching the collision avoidance on and off



3. Press the "Sim. rec." softkey.



4. Press the "Other views" and "Machine space" softkeys.



During simultaneous recording, an active machine model is displayed.

10.2 Switching the collision avoidance on and off

Using "Settings", you have the option of separately activating or deactivating the collision monitoring for the Machine operating area (operating modes, AUTO, JOG and MDI) separately for the machine and tools.

Using machine data, you define from which protection level the collision monitoring for the machine or the tool can be activated or deactivated in the operating modes JOG/MDI or AUTO.



Machine manufacturer

Please refer to the machine manufacturer's specifications.

Setting	Effect
JOG/MDI operating mode Collision avoidance	They switch the collision monitoring for the operating modes JOG/MDI completely on or off.
AUTO mode Collision avoidance	They switch the collision monitoring for the operating mode AUTO completely on or off.
JOG/MDI Machine	If the collision monitoring for the JOG/MDI operating modes is activated, then as a minimum, the machine protection areas are monitored. The parameter cannot be changed.
AUTO Machine	If the collision monitoring for the AUTO operating mode is activated, then as a minimum, the machine protection areas are monitored. The parameter cannot be changed.
JOG/MDI Tools	They switch the collision monitoring of the tool protection areas for the operating modes JOG/MDI on or off.
AUTO Tools	They switch the collision monitoring of the tool protection areas for the operating mode AUTO on or off.

Procedure



1. Select the "Machine" operating area.



2. Select the "JOG", "MDI" or "AUTO" mode.



3. Press the menu forward key and the "Settings" softkey.



4. Press the "Collision avoidance" softkey.
The "Collision Avoidance" window opens.



5. In the "Collision avoidance" line for the required operating modes (e.g. for JOG/MDI), select the entry "On" to activate the collision avoidance or "Off" to deactivate collision avoidance.
6. Deactivate the "Tools" checkbox if you only want to monitor the machine protection areas.

Tool management

11.1 Lists for the tool management

All tools and also all magazine locations that have been created or configured in the NC are displayed in the lists in the Tool area.

All lists display the same tools in the same order. When switching between the lists, the cursor remains on the same tool in the same screen segment.

The lists have different parameters and softkey assignments. Switching between lists is a specific change from one topic to the next.

- **Tool list**

All parameters and functions required to create and set up tools are displayed.

- **Tool wear**

All parameters and functions that are required during operation, e.g. wear and monitoring functions, are listed here.

- **Magazine**

You will find the magazine and magazine location-related parameters and functions for the tools/ magazine locations here.

- **Tool data OEM**

This list can be freely defined by the OEM.

Sorting the lists

You can change the sorting within the lists:

- acc. to the magazine
- acc. to the name (tool identifier, alphabetic)
- according to the tool type
- according to the T number (tool identifier, numerical)
- According to D number

Filtering the lists

You can filter the lists according to the following criteria:

- only display the first cutting edge
- only tools that are ready to use
- only tools that have reached the pre-alarm limit

- only locked tools
- Only tools with active code

Search functions

You have the option of searching through the lists according to the following objects:

- Tool
- Magazine location
- Empty location



Machine manufacturer

Please refer to the machine manufacturer's specifications.

11.2 Magazine management

Depending on the configuration, the tool lists support a magazine management.

Magazine management functions

- Press the "Magazine" horizontal softkey to obtain a list that displays tools with magazine-related data.
- The Magazine / Magazine location column is displayed in the lists.
- In the default setting, the lists are displayed sorted according to magazine location.
- The magazine selected via the cursor is displayed in the title line of each list.
- The "Magazine selection" vertical softkey is displayed in the tool list.
- You can load and unload tools to and from a magazine via the tool list.



Machine manufacturer

Please refer to the machine manufacturer's specifications.

11.3 Tool types

A number of tool types are available when you create a new tool. The tool type determines which geometry data is required and how it will be computed.



Machine manufacturer

Please refer to the machine manufacturer's specifications.

Tool types

New tool - favorites		
Typ	Identifier	Tool position
120	End mill	
140	Facing tool	
200	Twist drill	
220	Center drill	
240	Tap	
710	3D milling probe	
711	Edge tracer	
110	Cylindr. ball end	
111	Conical ball end	
121	End mill corner round.	
155	Bevelled cutter	
156	Beveled cutter corner	
157	Tap. die-sink. cutter	

Figure 11-1 Favorites-standard selection for a milling machine

New tool - milling cutter		
Typ	Identifier	Tool position
100	Milling tool	
110	Cylindr. ball end	
111	Conical ball end	
120	End mill	
121	End mill corner round.	
130	Angle head cutter	
131	Corn.round.ang.hd.cut	
140	Facing tool	
145	Thread cutter	
150	Side mill	
151	Saw	
155	Bevelled cutter	
156	Beveled cutter corner	
157	Tap. die-sink. cutter	
160	Drill&thread cut.	

Figure 11-2 Available tools in the "New Tool - Milling Cutter" window







New tool - drill		
Typ	Identifier	Tool position
200	Twist drill	
205	Solid drill	
210	Boring bar	
220	Center drill	
230	Countersink	
231	Counterbore	
240	Tap	
241	Fine tap	
242	Tap, Whitworth	
250	Reamer	

Figure 11-3 Available tools in the "New Tool - Drill" window











New tool - special tools		
Type	Identifier	Tool position
700	Slotting saw	
710	3D probe	
711	Edge finder	
712	Mono probe	
713	L probe	
714	Star probe	
725	Calibrating tool	
730	Stop	
900	Auxiliary tools	
	Multitool	

Figure 11-4 Available tools in the "New Tool - Special Tools" window

11.4 Tool dimensioning

This section provides an overview of the dimensioning of tools.

Tool types

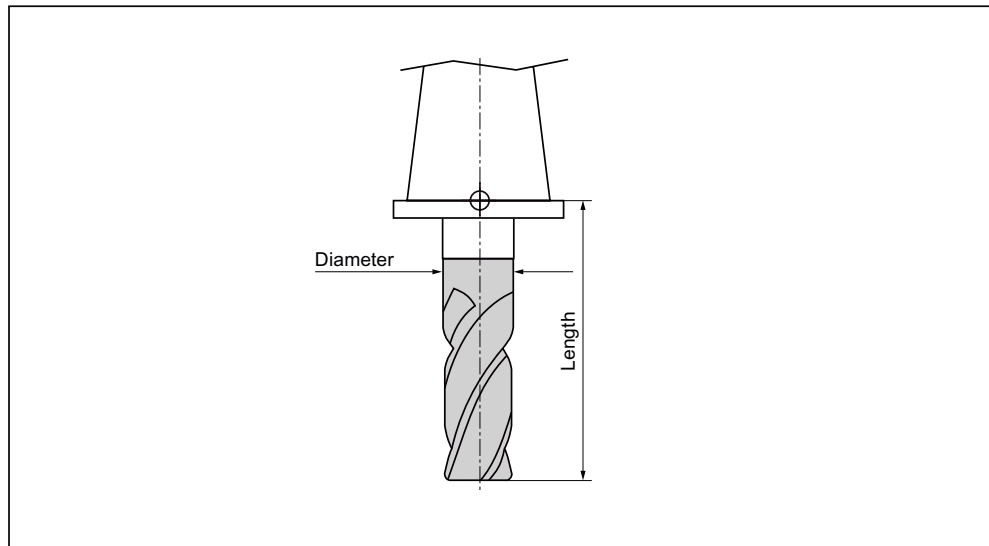

Figure 11-5 End mill (Type 120)

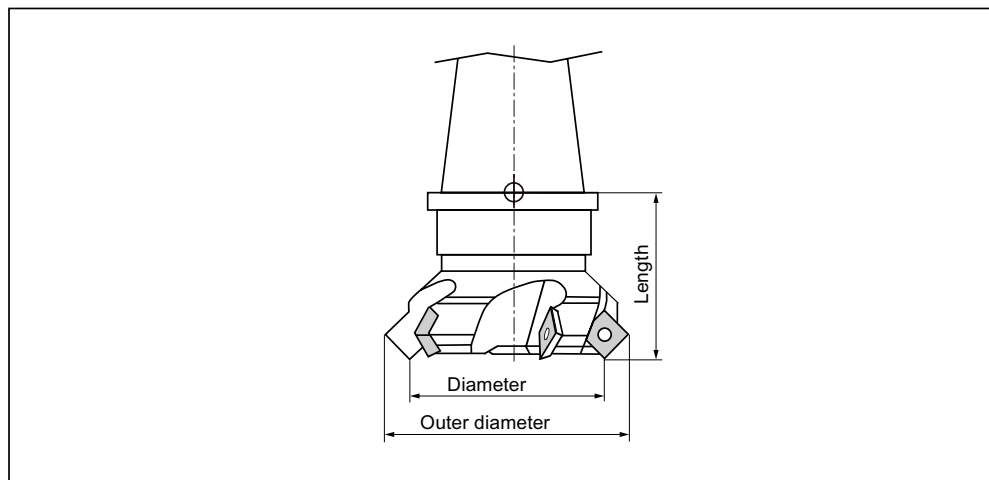

Figure 11-6 Face mill (Type 140)

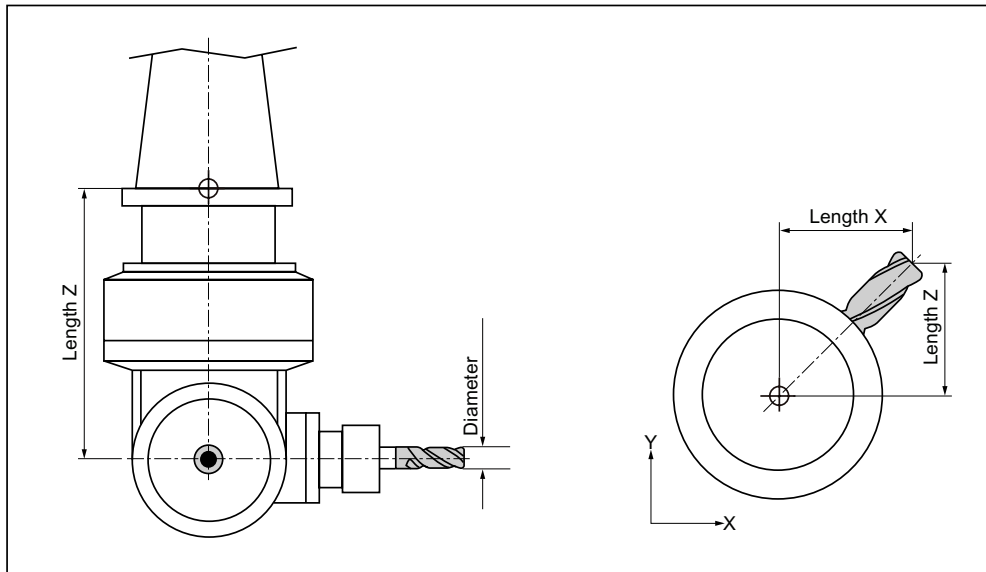

Figure 11-7 Angle head cutter (Type 130)

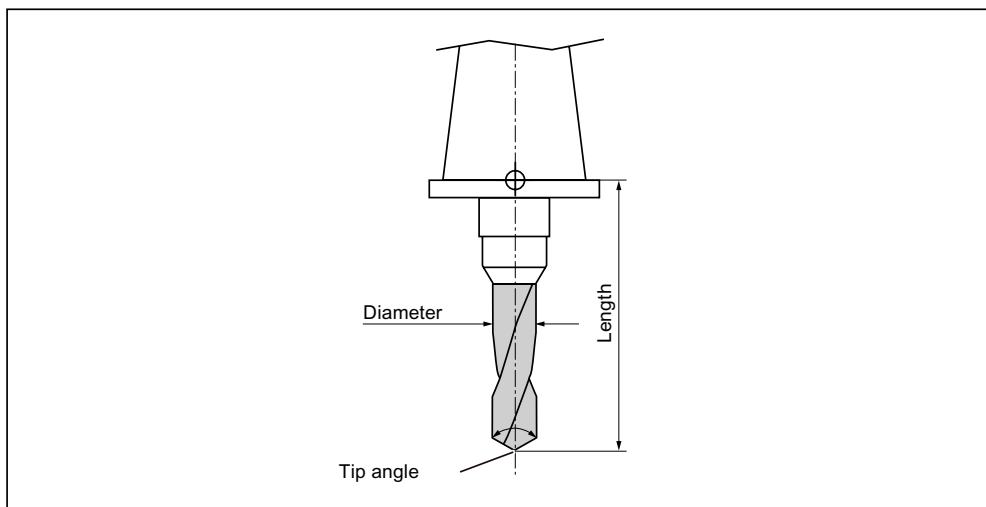

Figure 11-8 Drill (Type 200)

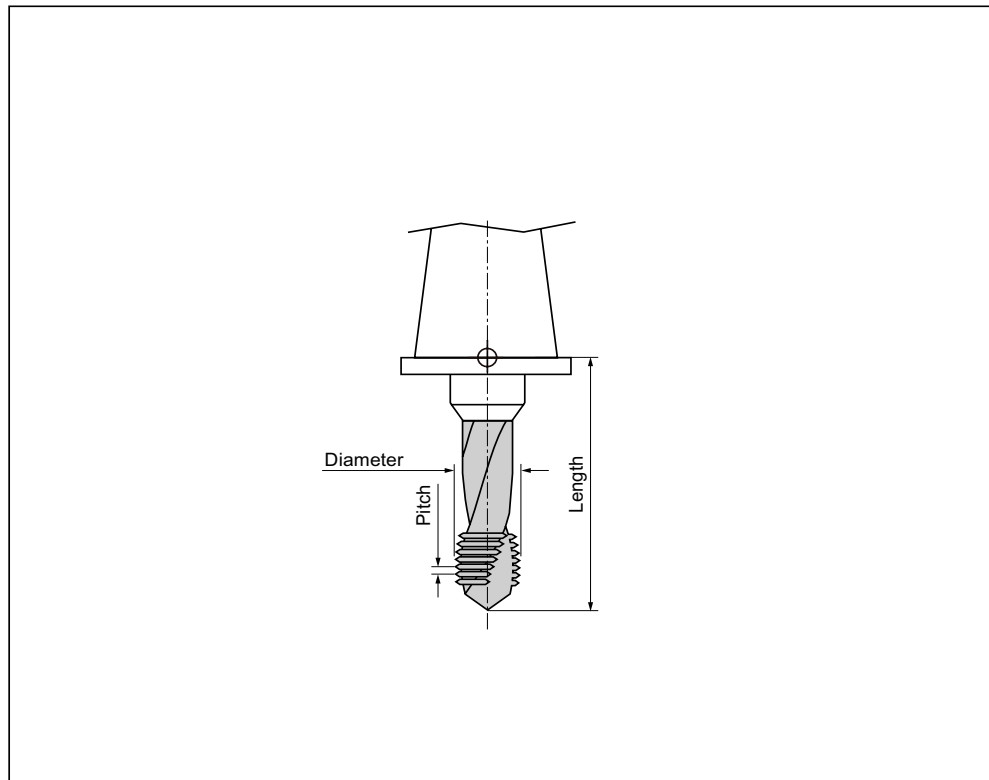

Figure 11-9 Tap (Type 240)

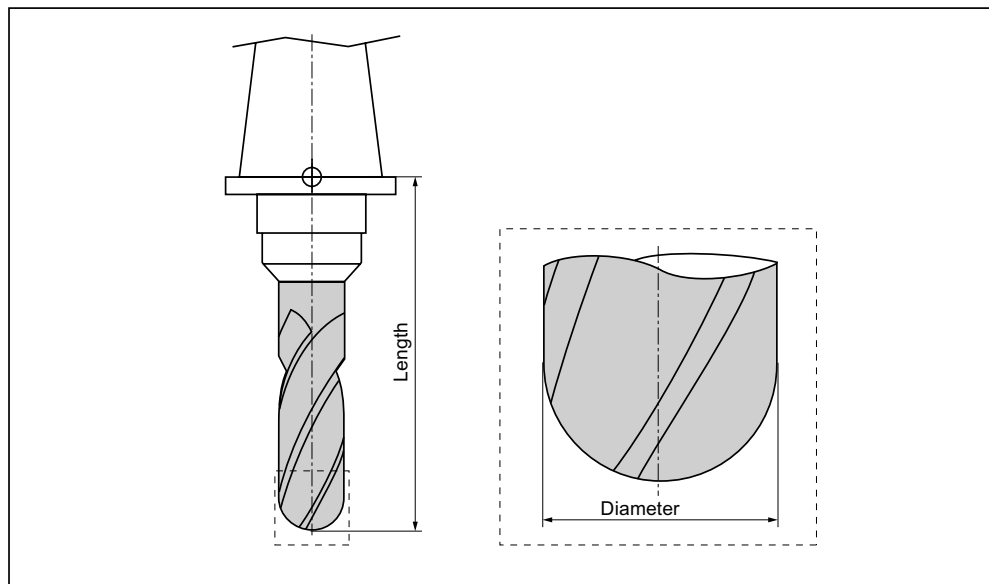

Figure 11-10 3D tool with an example of a cylindrical die-sinking cutter (Type 110)

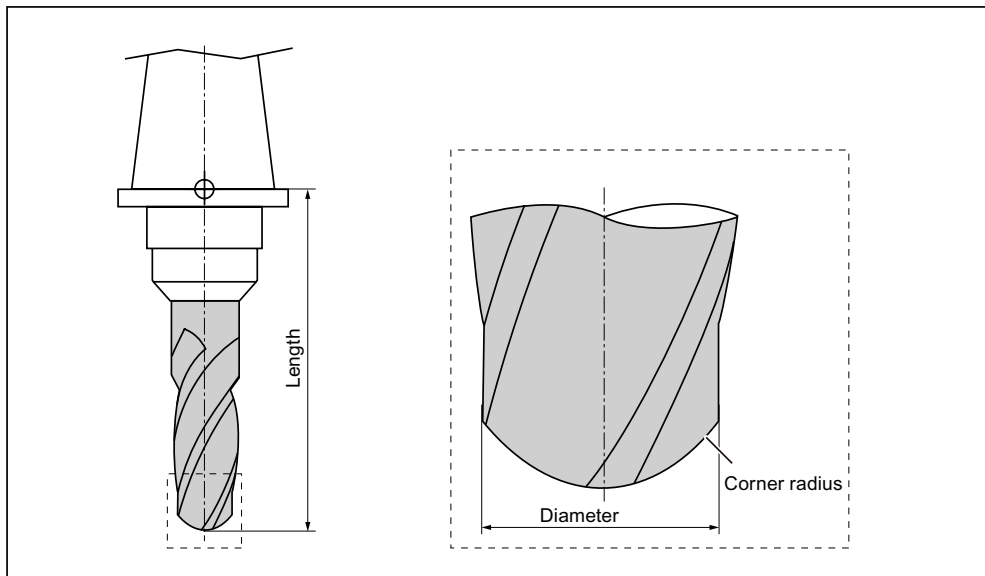

Figure 11-11 3D tool type with an example of a ballhead cutter (Type 111)

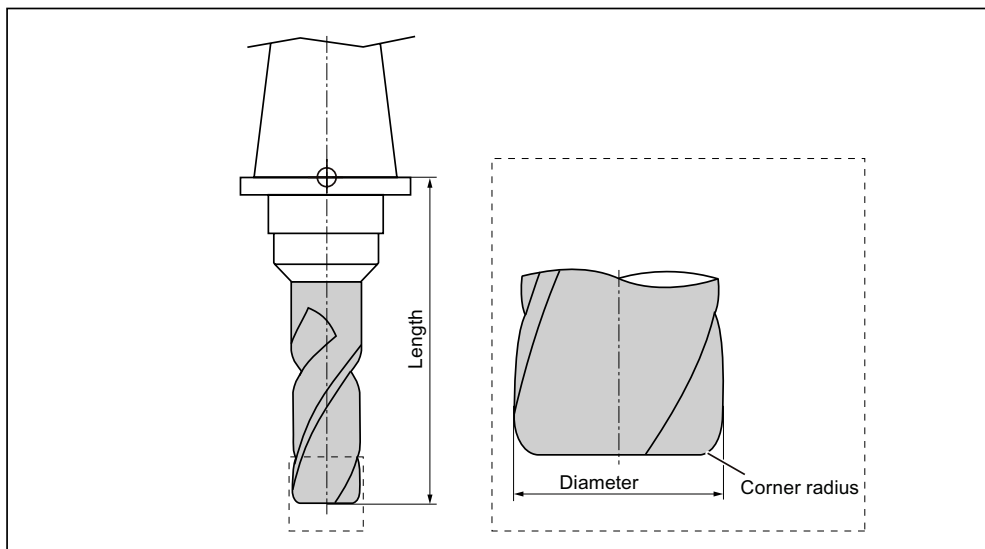

Figure 11-12 3D tool with an example of an end mill with corner rounding (Type 121)

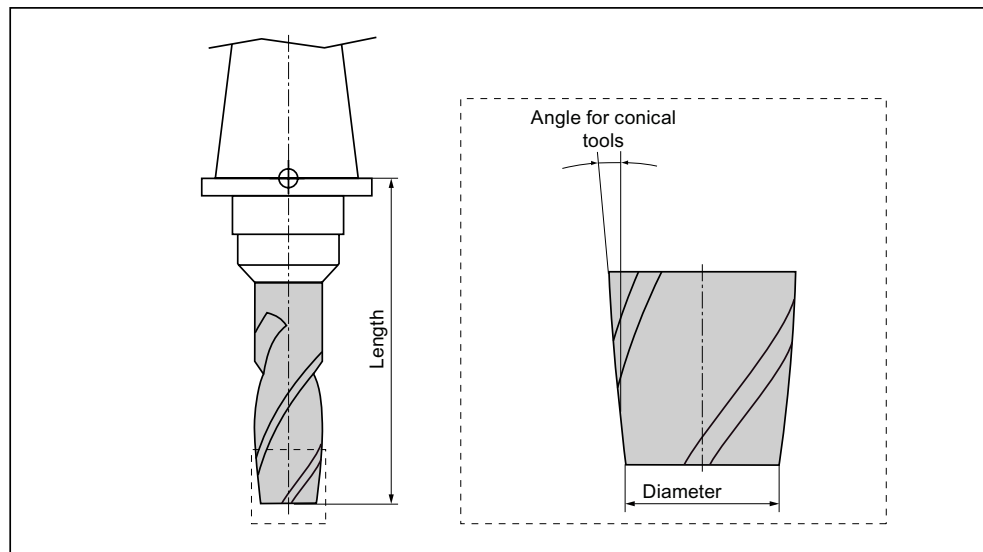

Figure 11-13 3D tool type with an example of a bevel cutter (Type 155)

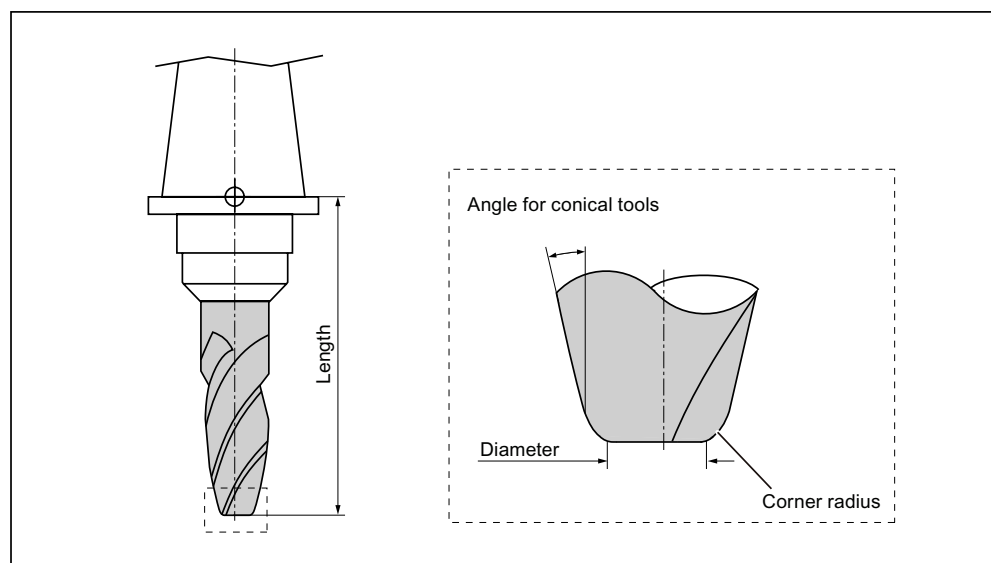

Figure 11-14 3D tool with an example of a bevel cutter with corner rounding (Type 156)

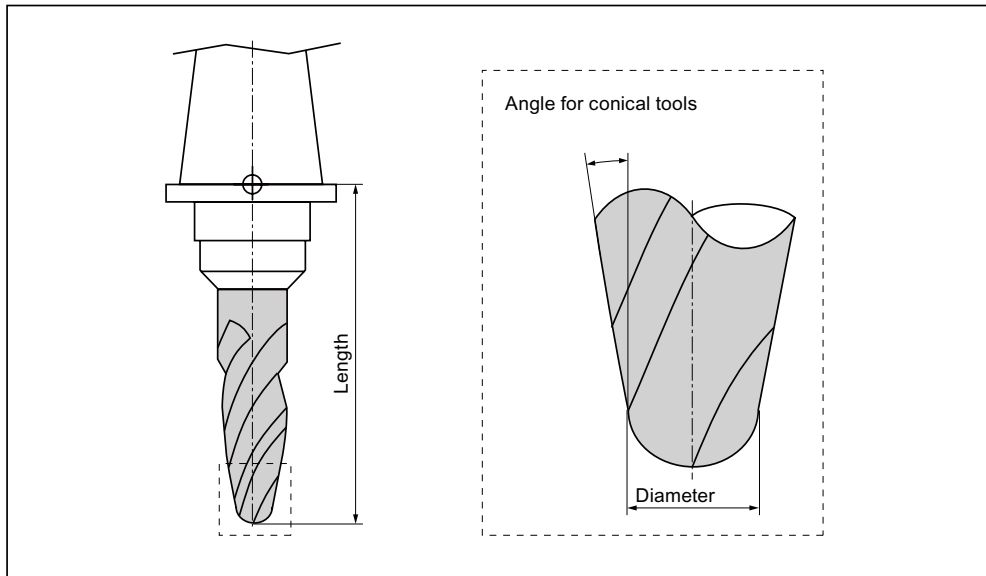

Figure 11-15 3D tool with an example of a tapered die-sinking cutter (Type 157)

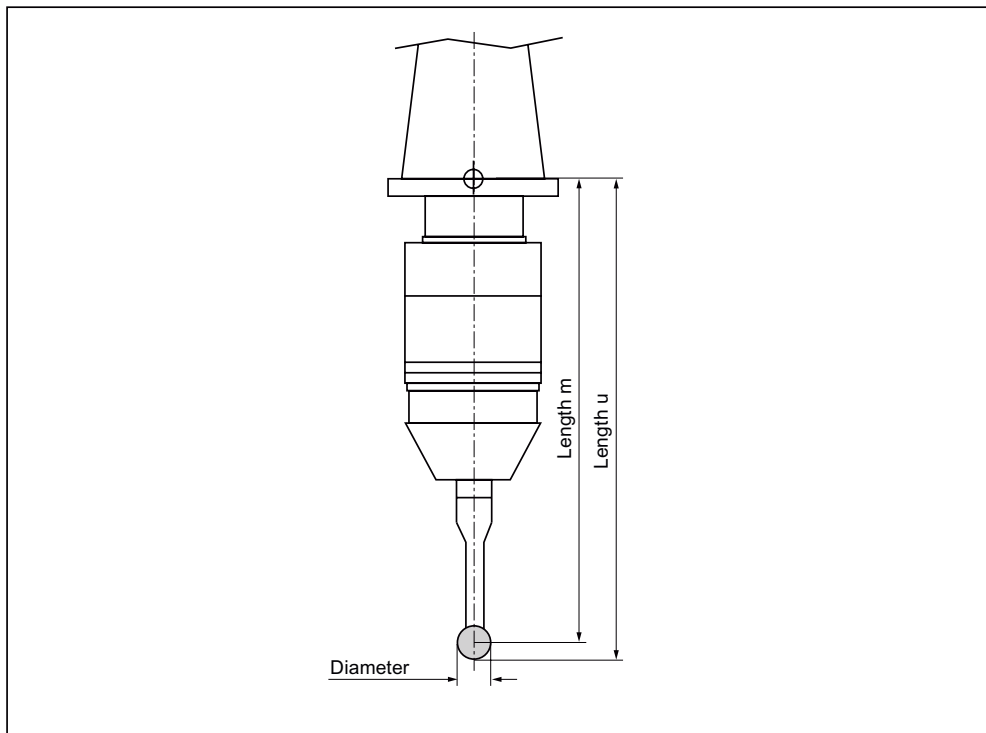

Figure 11-16 Electronic workpiece probe



Machine manufacturer

The tool length of the workpiece probe is measured to the center of the ball (length m) or to the ball circumference (length u).

Please refer to the machine manufacturer's specifications.

Note



An electronic workpiece probe must be calibrated before use.



11.5 Tool list

All parameters and functions that are required to create and set up the tools are displayed in the tool list.

Each tool is uniquely identified by the tool identifier and the sister tool number.

Tool parameters

Column heading	Meaning
Location BS   * If activated in magazine selection	Magazine/location number <ul style="list-style-type: none"> The magazine location numbers The magazine number is specified first, followed by the location number in the magazine. If there is only one magazine, only the location number is displayed. <ul style="list-style-type: none"> Load position in the load magazine The following icons can also be displayed for other magazine types (e.g. for a chain): <ul style="list-style-type: none"> Spindle location as an icon Locations for gripper 1 and gripper 2 (applies only when a spindle with dual gripper is used) as icons.
Type	Tool type Specific tool offset data is displayed depending on the tool type (represented as an icon).
	You have the option of changing the tool type using the <SELECT> key.
Tool name	The tool is identified by the name and the sister tool number. You may enter the names as text or numbers. Note: The maximum length of tool names is 31 ASCII characters. The number of characters is reduced for Asian characters or Unicode characters. The following special characters are not permitted: # ".
ST	Sister tool number (for sister tool strategy)
D	Cutting edge number
Length	Tool length Geometry data, length
Radius	Tool radius
Tip angle or Pitch	Tip angle for Type 200 - twist drill and Type 220 - centering tool and Type 230 countersink Pitch for Type 240 - tap

Column heading	Meaning
N	Number of teeth for Type 100 - milling tool, Type 110 - ball end mill for cylindrical die-sinking cutter, Type 111 - ball end mill or tapered die-sinking cutter, Type 120 - end mill, Type 121 - end mill with corner rounding, Type 130 - angle head cutter, Type 131 - angle head cutter with corner rounding, Type 140 - facing tool, Type 150 - side mill, Type 155 - bevel cutter, Type 156 - bevel cutter with corner rounding and Type 157 - tapered die-sinking cutter.
	Direction of spindle rotation <input type="checkbox"/> Spindle is not switched on <input type="checkbox"/> CW spindle rotation <input type="checkbox"/> CCW spindle rotation
	Coolant 1 and 2 (e.g. internal and external cooling) can be switched on and off. The coolant infeed at the machine does not necessarily have to be set-up.
M1 - M4	Other tool-specific functions such as additional coolant infeed, monitoring functions for speed, tool breakage, etc.

Further parameters

If you have set up unique cutting edge numbers, these are displayed in the first column.

Column heading	Meaning
D no.	Unique cutting edge number
SN	Cutting edge number
EC	Setup offsets
	Display of the existing setup offsets

You use the configuration file to specify the selection of parameters in the list.



Software option

In order to be able to manage the parameter spindle direction of rotation, coolant and tool-specific functions (M1-M4), you require the "ShopTurn/ShopMill" option.



Machine manufacturer







Please refer to the machine manufacturer's specifications.

References

Information on the configuration and setting up of the tool list can be found in the following references:

Commissioning Manual SINUMERIK Operate (IM9) / SINUMERIK 840D sl

Icons in the tool list

Icon/ Marking		Meaning
Tool type		
Red "X"		The tool is disabled.
Yellow triangle pointing downward		The prewarning limit has been reached.
Yellow triangle pointing upward		The tool is in a special state. Place the cursor on the marked tool. A tooltip provides a short description.
Green border		The tool is preselected.
Magazine/location number		
Green double arrow		The magazine location is positioned at the change position.
Gray double arrow (configurable)		The magazine location is positioned at the loading position.
Red "X"		The magazine location is disabled.

Procedure

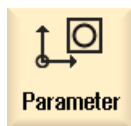

1. Select the "Parameter" operating area.



2. Press the "Tool list" softkey.
The "Tool List" window opens.

See also

Displaying tool details (Page 564)

Changing a tool type (Page 567)

11.5.1 Additional data

The following tool types require geometry data that is not included in the tool list display.

Tools with additional geometry data

Tool type	Additional parameters
111 Conical ballhead cutter	Corner radius
121 End mill with corner rounding	Corner radius
130 Angle head cutter	Geometry length (length X, length Y, length Z) Wear length (Δ length X, Δ length Y, Δ length Z) Adapter length (length X, length Y, length Z) V (direction vector 1 - 6) Vector X, vector Y, vector Z
131 Angle head cutter with corner rounding	Geometry length (length X, length Y, length Z) Corner radius Wear length (Δ length X, Δ length Y, Δ length Z) Adapter length (length X, length Y, length Z) V (direction vector 1 - 6) Vector X, vector Y, vector Z
140 Face milling	External radius Tool angle
155 Bevel cutter	Taper angle
156 Bevel cutter with corner rounding	Corner radius Taper angle
157 Conical die-milling cutter	Taper angle
585 Calibration tool	Geometry length (length X, length Y, length Z) Wear length (Δ length X, Δ length Y, Δ length Z)
710 3D-probe milling	Geometry length (length X, length Y, length Z) Wear length (Δ length X, Δ length Y, Δ length Z)
712 Mono-probe	Geometry length (length X, length Y, length Z) Wear length (Δ length X, Δ length Y, Δ length Z)
713 L-probe	Geometry length (length X, length Y, length Z) Wear length (Δ length X, Δ length Y, Δ length Z) Boom length (length)
714 Star-type probe	Geometry length (length X, length Y, length Z) Wear length (Δ length X, Δ length Y, Δ length Z) Outer diameter (\varnothing)

You can use the configuration file to specify the data to be displayed for specific tool types in the "Additional Data" window.



Machine manufacturer

Please refer to the machine manufacturer's specifications.

Procedure



1. The tool list is opened.



2. In the list, select an appropriate tool, e.g. an angle head cutter.

3. Press the "Additional data" softkey.

The "Additional Data - ..." window opens.

The "Additional data" softkey is only active if a tool for which the "Additional Data" window is configured is selected.

11.5.2 Creating a new tool

When creating a new tool, the "New tool - favorites" window offers you a number of selected tool types, known as "favorites".

If you do not find the desired tool type in the favorites list, then select the milling, drilling or special tool using the corresponding softkeys.

Procedure



1. The tool list is opened.

2. Place the cursor in the tool list at the position where the new tool should be stored.

For this, you can select an empty magazine location or the NC tool memory outside of the magazine.

You may also position the cursor on an existing tool in the area of the NC tool memory. Data from the displayed tool will not be overwritten.



3. Press the "New tool" softkey.



The "New tool - favorites" window opens.

- OR -



...



If you want to create a tool that is not in the "Favorites" list, press the softkey "Cutters 100-199", "Drill 200-299", or "Spec.tool 700-900".

The "New tool - milling cutter", "New tool - drill", or "New tool - special tools" window opens.

4. Select the tool by placing the cursor on the corresponding icon.

5. Press the "OK" softkey.

The tool is added to the tool list with a predefined name. If the cursor is located on an empty magazine location in the tool list, then the tool is loaded to this magazine location.

The tool creation sequence can be defined differently.

Multiple load points

If you have configured several loading points for a magazine, then the "Select loading point" window appears when a tool is created directly in an empty magazine location or when the "Load" softkey is pressed.

Select the required load point and confirm with the "OK" softkey.

Additional data

If configured accordingly, the "New tool" window opens after the required tool has been selected and confirmed with "OK".

You can define the following data in this window:

- Names
- Tool location type
- Size of tool

References:

For a description of configuration options, refer to the

Commissioning Manual SINUMERIK Operate / SINUMERIK 840D sl

11.5.3 Measuring the tool

You can measure the tool offset data for the individual tools directly from the tool list.

Note

Tool measurement is only possible with an active tool.

Procedure



1. The tool list is opened.



2. Select the tool that you want to measure in the tool list and press the "Measure tool" softkey.



You jump to the "JOG" operating area and the tool to be measured is entered in the "T" field in the "Length Manual" screen.



3. Select the cutting edge number D and the number of the replacement tool ST of the tool.

4. Approach the workpiece in the Z direction, scratch it with a turning spindle and enter the set position Z0 of the workpiece edge.



5. Press the "Set length" softkey.
The tool length is calculated automatically and entered in the tool list.

11.5.4 Managing several cutting edges

In the case of tools with more than one cutting edge, a separate set of offset data is assigned to each cutting edge. The number of possible cutting edges depends on the controller configuration.

Tool cutting edges that are not required can be deleted.

Procedure



1. The tool list is opened.
2. Position the cursor on the tool for which you would like to store more cutting edges.



3. Press the "Edges" softkey in the "Tool list".



4. Press the "New cutting edge" softkey.

A new data set is stored in the list.

The cutting edge number is incremented by one and the offset data is assigned the values of the cutting edge on which the cursor is positioned.

5. Enter the offset data for the 2nd cutting edge.

6. Repeat this process if you wish to create more tool edge offset data.



7. Position the cursor on the cutting edge that you want to delete and press the "Delete cutting edge" softkey.

The data set is deleted from the list. The first tool cutting edge cannot be deleted.

11.5.5 Delete tool

Tools that are no longer in use can be deleted from the tool list for a clearer overview.

Procedure



1. The tool list is opened.



2. Place the cursor on the tool that you would like to delete.

3. Press the "Delete tool" softkey.

A safety prompt is displayed.



4. Press the "OK" softkey if you really want to delete the tool.

Use this softkey to delete the tool.

If the tool is in a magazine location, it is unloaded and then deleted.

Multiple load points - tool in magazine location

If you have configured several loading points for a magazine, then the "Loading Point Selection" window appears after pressing the "Delete tool" softkey.

Select the required load point and press the "OK" softkey to unload and delete the tool.

11.5.6 Loading and unloading tools

You can load and unload tools to and from a magazine via the tool list. When a tool is loaded, it is taken to a magazine location. When it is unloaded, it is removed from the magazine and stored in the NC memory.

When you are loading a tool, the application automatically suggests an empty location. You may also directly specify an empty magazine location.

You can unload tools from the magazine that you are not using at present. HMI then automatically saves the tool data in the NC memory.

Should you want to use the tool again later, simply load the tool with the tool data into the corresponding magazine location again. Then the same tool data does not have to be entered more than once.

Procedure



1. The tool list is opened.



2. Place the cursor on the tool that you want to load into the magazine (if the tools are sorted according to magazine location number you will find it at the end of the tool list).
3. Press the "Load" softkey.

The "Load to..." window opens.

The "... location" field is initialized with the number of the first empty magazine location.



4. Press the "OK" softkey to load the tool into the suggested location.

- OR -

Enter the location number you require and press the "OK" softkey.



- OR -

Press the "Spindle" softkey.



The tool is loaded into the specified magazine location or spindle.

Loading empty magazine location directly with tool



1. Position the cursor at an empty magazine location where you want to load a tool and press the "Load" softkey.



The "Load with ..." window opens.

Select the desired tool in the " ... Tool" field and press the "OK" softkey.

Several magazines

If you have configured several magazines, the "Load to ..." window appears after pressing the "Load" softkey.

If you do not want to use the suggested empty location, then enter your desired magazine and magazine location. Confirm your selection with "OK".

Multiple load points

If you have configured several loading points for a magazine, then the "Loading Point Selection" window appears after pressing the "Load" softkey.

Select the required loading point and confirm with "OK".

Unloading tools



1. Place the cursor on the tool that you would like to unload from the magazine and press the "Unload" softkey.
2. Select the required load point in the "Loading Point Selection" window.
3. Confirm your selection with "OK".



- OR -

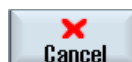

Undo your selection with "Cancel".

11.5.7 Selecting a magazine

You can directly select the buffer memory, the magazine, or the NC memory.

Procedure



1. The tool list is opened.



2. Press the "Magazine selection" softkey.

If there is only one magazine, you will move from one area to the next (i.e. from the buffer memory to the magazine, from the magazine to the NC memory, and from the NC memory back to the buffer memory) each time you press the softkey. The cursor is positioned at the beginning of the magazine each time.

- OR -



If there is more than one magazine, the "Magazine Selection" window opens. Position the cursor on the desired magazine in this window and press the "Go to" softkey.

The cursor jumps directly to the beginning of the specified magazine.

Hiding magazines

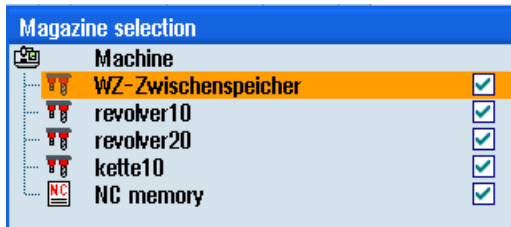

Deactivate the checkbox next to the magazines that you do not want to appear in the magazine list.

The magazine selection behavior with multiple magazines can be configured in different ways.



Machine manufacturer

Please refer to the machine manufacturer's specifications.

References

For a description of configuration options, refer to the Commissioning Manual SINUMERIK Operate / SINUMERIK 840D sl

11.5.8 Code carrier connection (only 840D sl)

You have the option of configuring a connection to MCIS TDI Ident Connection.

This means that the following functions are available in SINUMERIK Operate:

- Creating a new tool from code carrier
- Unloading tools on code carrier



Software option

In order to use the functions, you require the option "MC Information System TDI Ident Connection".

References

Further details on tool management with code carrier and the configuration of the user interface in SINUMERIK Operate can be found in the following reference:

- Function Manual MCIS TDI Ident Connection
- Commissioning Manual SINUMERIK Operate (IM9) / SINUMERIK 840D sl

With a code carrier connection, in the list of favorites, there is also a tool available.

New tool – favorites		
Type	Identifier	Tool position
	Tool from code carrier	
120	- End mill	
140	- Facing tool	
200	- Twist drill	
220	- Center drill	
240	- Tap	
710	- 3D milling probe	
711	- Edge finder	
110	- Ball nose end mill	
111	- Conical ball end	
121	- End mill corner rounding	
155	- Bevelled cutter	
156	- Bevelled cutter corner	
157	- Tap, die-sink. cutter	
	Multitool	

Figure 11-17 New tool from code carrier in the list of favorites

Creating a new tool from code carrier



1. The tool list is opened.
2. Place the cursor in the tool list at the position where the new tool should be created.
To do this, you can select an empty magazine location or the NC tool memory outside of the magazine.
You may also position the cursor on an existing tool in the area of the NC tool memory. Data from the displayed tool will not be overwritten.



3. Press the "New tool" softkey.



The "New Tool - Favorites" window is opened.



4. Position the cursor on the entry "Tool from code carrier" and press the "OK" softkey.

The tool data is read from the code carrier, and is displayed in the "New tool" window with the tool type, tool name and possibly with certain parameters.



5. Press the "OK" softkey.

The tool is added to the tool list with the specified name. If the cursor is located on an empty magazine location in the tool list, then the tool is loaded to this magazine location.

The tool creation sequence can be defined differently.

Unloading tool on code carrier



1. The tool list is opened.



2. Place the cursor on the tool that you would like to unload from the magazine and press the "Unload" and "On code carrier" softkeys.



The tool is unloaded and the data of the tool are written to the code carrier.

According to the corresponding setting, the unloaded tool on the code carrier is deleted from the MC memory after reading out the code carrier.

Deleting tool on code carrier



1. The tool list is opened.
2. Position the cursor on the tool on code carrier that you want to delete.
3. Press the "Delete tool" and "On code carrier" softkeys.
The tool is unloaded and the data of the tool are written to the code carrier. The tool is then deleted from the NC memory.

The deletion of the tool can be set differently, i.e. the "On code carrier" softkey is not available.

References

A description of the configuration options can be found in the following reference:

Commissioning Manual SINUMERIK Operate (IM9) / SINUMERIK 840D sl

11.6 Tool wear

All parameters and functions that are required during operation are contained in the tool wear list.

Tools that are in use for long periods are subject to wear. You can measure this wear and enter it in the tool wear list. The controller then takes this information into account when calculating the tool length or radius compensation. This ensures a consistent level of accuracy during workpiece machining.

Monitoring types

You can automatically monitor the tools' working times via the workpiece count, tool life or wear.

Note

Combination of monitoring types

You have the option to activate the monitoring of a tool by type or any combination of monitoring types.



In addition, you can disable tools when you no longer wish to use them.



Machine manufacturer

Please refer to the machine manufacturer's specifications.

Tool parameters

Column heading	Meaning
Location	Magazine/location number
BS	<ul style="list-style-type: none"> The magazine location numbers The magazine number is specified first, followed by the location number in the magazine. If there is only one magazine, only the location number is displayed. Load position in the load magazine
	<p>The following icons can also be displayed for other magazine types (e.g. for a chain):</p> <ul style="list-style-type: none"> Spindle location as an icon
	<ul style="list-style-type: none"> Locations for gripper 1 and gripper 2 (applies only when a spindle with dual gripper is used) as icons.
* If activated in magazine selection	







Column heading	Meaning
Type	Tool type Depending on the tool type (represented by an icon), certain tool offset data is enabled.
Tool name	The tool is identified by the name and the replacement tool number. You can enter the name as text or number. Note: The maximum length of tool names is 31 ASCII characters. The number of characters is reduced for Asian characters or Unicode characters. The following special characters are not permitted: # " .
ST	Replacement tool number (for replacement tool strategy).
D	Cutting edge number
Δ Length	Length wear
Δ Radius	Radius wear
T C	Selection of tool monitoring - by tool life (T) - by count (C) - by wear (W) The wear monitoring is configured via a machine data item. Please refer to the machine manufacturer's instructions.
Tool life Workpiece count Wear * *Parameter depends on selection in TC	Tool life Number of workpieces Tool wear
Setpoint	Setpoint for tool life, workpiece count, or wear
Prewarning limit	Specification of the tool life, workpiece count or wear at which a warning is displayed.
G	The tool is disabled when the checkbox is selected.

Further parameters

If you have created unique cutting edge numbers, they will be displayed in the first column.

Column heading	Meaning
D no.	Unique cutting edge number
SN	Cutting edge number
SC	Setting-up offsets
	Display of the available setup offsets

Icons in the wear list

Icon/ Marking		Meaning
Tool type		
Red "X"		The tool is disabled.
Yellow triangle pointing downward		The prewarning limit has been reached.
Yellow triangle pointing upward		The tool is in a special state. Place the cursor on the marked tool. A tooltip provides a short description.
Green border		The tool is preselected.
Magazine/location number		
Green double arrow		The magazine location is positioned at the change position.
Gray double arrow (configurable)		The magazine location is positioned at the loading position.
Red "X"		The magazine location is disabled.

Procedure



Parameter

1. Select the "Parameter" operating area.



Tool wear

2. Press the "Tool wear" softkey.

See also

Displaying tool details (Page 564)

Changing a tool type (Page 567)

11.6.1 Reactivating a tool

You can replace disabled tools or make them ready for use again.

Preconditions

In order to reactivate a tool, the monitoring function must be activated and a setpoint must be stored.

Procedure



1. The tool wear list is opened.



2. Position the cursor on the disabled tool which you would like to reuse.

3. Press the "Reactivate" softkey.

The value entered as the setpoint is entered as the new tool life or workpiece count.

The disabling of the tool is canceled.

Reactivating and positioning

When the "Reactivate with positioning" function is configured, the selected tool's magazine location will also be positioned at a loading point. You can exchange the tool.

Reactivation of all monitoring types

When the "Reactivation of all monitoring types" function is configured, all the monitoring types set in the NC for a tool are reset during reactivation.



Machine manufacturer

Please refer to the machine manufacturer's specifications.

References

Commissioning Manual SINUMERIK Operate / SINUMERIK 840D sl

Multiple load points

If you have configured several loading points for a magazine, then the "Loading Point Selection" window appears after pressing the "Load" softkey.

Select the required load point and confirm with the "OK" softkey.

11.7 Tool data OEM

You have the option of configuring the list according to your requirements.

Refer to the following document for more information on configuring OEM tool data:

Commissioning Manual SINUMERIK Operate (IM9) / SINUMERIK 840D sl

Procedure

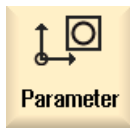

1. Select the "Parameter" operating area.





2. Press the "OEM tool" softkey.

11.8 Magazine

Tools are displayed with their magazine-related data in the magazine list. Here, you can take specific actions relating to the magazines and the magazine locations.

Individual magazine locations can be location-coded or disabled for existing tools.

Tool parameters

Column heading	Meaning
Location	Magazine/location number
BS	<ul style="list-style-type: none"> The magazine location numbers The magazine number is specified first, followed by the location number in the magazine. If there is only one magazine, only the location number is displayed. Load position in the load magazine
 	<p>The following icons can also be displayed for other magazine types (e.g. for a chain):</p> <ul style="list-style-type: none"> Spindle location as an icon Locations for gripper 1 and gripper 2 (applies only when a spindle with dual gripper is used) as icons
* If activated in magazine selection	
Type	Tool type Depending on the tool type (represented by an icon), certain tool offset data is enabled.
Tool name	The tool is identified by the name and the replacement tool number. You can enter the name as text or number. Note: The maximum length of tool names is 31 ASCII characters. The number of characters is reduced for Asian characters or Unicode characters. The following special characters are not permitted: # ".
ST	Replacement tool number (for replacement tool strategy).
D	Cutting edge number
G	Disabling of the magazine location.
Mag.loc. type	Display of magazine location type.
Tool.loc. type	Display of tool location type.
Ü	Marking of a tool as oversized. The tool occupies two half locations left, two half locations right, one half location top and one half location bottom in a magazine.
P	Fixed location coding. The tool is permanently assigned to this magazine location.

Further parameters

If you have created unique cutting edge numbers, they will be displayed in the first column.

Column heading	Meaning
D no.	Unique cutting edge number
SN	Cutting edge number

Magazine list icons

Icon/ Marking		Meaning
Tool type		
Red "X"	✘	The tool is disabled.
Yellow triangle pointing downward	▽	The prewarning limit has been reached.
Yellow triangle pointing upward	△	The tool is in a special state. Place the cursor on the marked tool. A tooltip provides a short description.
Green border	□	The tool is preselected.
Magazine/location number		
Green double arrow	↔	The magazine location is positioned at the change position.
Gray double arrow (configurable)	↔	The magazine location is positioned at the loading position.
Red "X"	✘	The magazine location is disabled.

Procedure

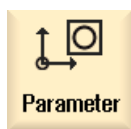

1. Select the "Parameter" operating area.



2. Press the "Magazine" softkey.

See also

Displaying tool details (Page 564)

Changing a tool type (Page 567)

11.8.1 Positioning a magazine

You can position magazine locations directly on the loading point.

Procedure



1. The magazine list is opened.

2. Place the cursor on the magazine location that you want to position onto the load point.



3. Press the "Position magazine" softkey.

The magazine location is positioned on the loading point.

Multiple load points

If you have configured several loading points for a magazine, then the "Loading Point Selection" window appears after pressing the "Position magazine" softkey.

Select the desired loading point in this window and confirm your selection with "OK" to position the magazine location at the loading point.

11.8.2 Relocating a tool

Tools can be directly relocated within magazines to another magazine location, which means that you do not have to unload tools from the magazine in order to load them into a different location.

When you are relocating a tool, the application automatically suggests an empty location. You may also directly specify an empty magazine location.

Buffer

You have the option of relocating the tool to buffer locations.



Machine manufacturer

Please refer to the machine manufacturer's specifications.

Procedure



1. The magazine list is opened.



2. Position the cursor on the tool that you wish to relocate to a different magazine location.

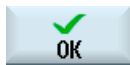

3. Press the "Relocate" softkey.

The "... relocate from location ... to location ..." window is displayed. The "Location" field is pre-assigned with the number of the first empty magazine location.

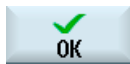

4. Press the "OK" softkey to relocate the tool to the recommended magazine location.

- OR -

Enter the required magazine, enter the location number and press the "OK" softkey.

- OR -

Enter the number "9998" or the number "9999" into the "... magazine" field in order to select the buffer as well as the required buffer location in the "Location" field.

- OR -



Press the "Spindle" softkey to load a tool into the spindle and press the "OK" softkey.



The tool is relocated to the specified magazine location, in the spindle or in the buffer.

Several magazines

If you have set up several magazines, then the "...relocate from magazine... location... to..." window appears after pressing the "Relocate" softkey.

Select the desired magazine and location, and confirm your selection with "OK" to load the tool.

11.8.3 Unload all tools

You have the option of unloading all tools from the magazine list. A single request successively unloads the tools from the list.

Requirement

The following requirements must be satisfied so that the "Unload all" softkey is displayed and available:

- Magazine management is set up
- There is no tool in the buffer / in the spindle



Machine manufacturer

Please refer to the machine manufacturer's specifications.

Procedure

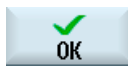

1. The magazine list is opened.
2. Press the "Unload all" softkey.
A prompt is displayed as to whether you really want to unload all tools.
3. Press the "OK" softkey to continue with the unloading of the tools.
The tools are unloaded from the magazine in ascending magazine location number order.
4. Press the "Cancel" softkey if you wish to cancel the unloading operation.

Multiple load points

For a magazine, if more than one loading point was set-up, using the "Select loading point" softkey, you have the option of opening a window in which you can assign a loading point to a magazine.

11.9 Graphic display

In addition to the list of tools, you can also display the tools and magazine locations in a dynamic graphic display.

The tools are displayed in the list in the order with their correct proportions.

The graphic display must be set up by the machine manufacturer.



Machine manufacturer

Please refer to the machine manufacturer's specifications.

References

For additional information, please refer to the following documentation:

Commissioning Manual SINUMERIK Operate (IM9) / SINUMERIK 840D sl

Graphic display of tools and magazine locations

Platz	Typ	Werkzeugname	ST	D	Länge	Ø			
1/1		3D_TASTER	1	1	217.337	6.000		<input type="checkbox"/>	<input type="checkbox"/>
1/2		BOHRER_12	1	1	121.954	12.000	118.0	<input checked="" type="checkbox"/>	<input type="checkbox"/>
1/3		PLANFRAESER_63	1	1	84.411	63.000		6	<input checked="" type="checkbox"/>
1/4		FRAESER_20	1	1	118.678	20.000		4	<input checked="" type="checkbox"/>
1/5		SPITZSENKER_25	1	1	82.822	25.000	90.0		<input checked="" type="checkbox"/>
1/6		FRAESER_KEG_16	1	1	118.559	16.000		4	<input checked="" type="checkbox"/>
1/7		STERNTASTER	1	1	209.082	3.000	0.0		<input type="checkbox"/>
1/8		FRAESER_10	1	1	121.886	10.000		3	<input checked="" type="checkbox"/>

Figure 11-18 Graphic display of tools and magazine locations

The following applies to the graphic display:

- If a tool is too long for the display, the maximum possible length is shown.
- Oversized tools are trimmed on the left and right sides.

- Tools that are not located in the magazine are displayed without toolholder.
- Disabled tools or magazine locations are marked by means of a red cross:

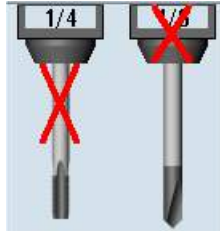

Note

Measuring tools type 713 / 714

So that the tools "L button" and "star probe" are displayed in the graphic tool display, enter in the "More data" window the additional Parameter "Boom length" or "External diameter".

Switching the graphical magazine display on/off



1. The tool list or wear or magazine list is opened.
2. Press the "Continue" and "Settings" softkeys.

The "Settings" window appears.

3. Activate the check box "Switch on graphic magazine display" in order to change into the non-graphic display of the lists.

11.10 Sorting tool management lists

When you are working with many tools, with large magazines or several magazines, it is useful to display the tools sorted according to different criteria. Then you will be able to find a specific tool more easily in the lists.

Procedure

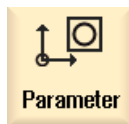

1. Select the "Parameter" operating area.



2. Press the "Tool list", "Tool wear" or "Magazine" softkey.

...



3. Press the ">>" and "Sort" softkeys.



The lists are displayed sorted numerically according to magazine location.

Tool types are used to sort tools with the same magazine location. Identical types (e.g. milling cutters), in turn, are sorted according to their radius value.



4. Press the "Acc. to type" softkey to display the tools arranged by tool type. Identical types (e.g. milling cutters) are sorted according to their radius value.

- OR -



Press the "Acc. to name" softkey to display the tool names in alphabetical order.

The replacement tool numbers are used to sort tools with the same names.

- OR -

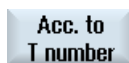

Press the "Acc. to T number" softkey to display the tool names sorted numerically.

- OR -



Press the "Acc. to D number" softkey to display the tools sorted by D number.

The list is sorted according to the specified criteria.

**Machine manufacturer**

Please refer to the machine manufacturer's specifications.

11.11 Filtering the tool management lists

The filter function allows you to filter-out tools with specific properties in the tool management lists.

For instance, you have the option of displaying tools during machining that have already reached the prewarning limit in order to prepare the corresponding tools to be loaded.

Filter criteria

- Only display the first cutting edge
- Only tools that are ready to use
- Only tools that have reached the prewarning limit
- Only tools with active code
- Only locked tools
- Only tools with remaining quantity of ... to ...
- Only tools with residual tool life of ... to ...
- Only tools with unloading marking
- Only tools with loading marking

**Machine manufacturer**

Please refer to the machine manufacturer's specifications.

Note**Multiple selection**

You have the option of selecting several criteria. You will receive an appropriate message if conflicting filter options are selected.

You can configure OR logic operations for the various filter criteria.

References

A description of the configuration options is provided in
SINUMERIK Operate (IM9) / SINUMERIK 840D sl Commissioning Manual

Procedure

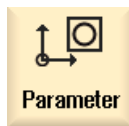

1. Select the "Parameter" operating area.



2. Press the "Tool list", "Tool wear" or "Magazine" softkey.

...



3. Press the ">>" and "Filter" softkeys.
The "Filter" window opens.

...



4. Activate the required filter criterion and press the "OK" softkey.
The tools that correspond to the selection criteria are displayed in the list.



The active filter is displayed in the window header.

11.12 Specific search in the tool management lists

There is a search function in all tool management lists, where you can search for the following objects:

- **Tools**

- You enter a tool name. You can narrow down your search by entering a replacement tool number.

You have the option of only entering a part of the name as search term.

- Enter the D number and, if necessary, activate the "Active D number" checkbox.

- **Magazine locations or magazines**

If only one magazine is configured, then the search is only made for the magazine location.

If several magazines are configured, then it is possible to search a specific magazine location in a specific magazine or just to search in a specific magazine.

- **Empty locations**

If the lists with the location type are used, then the empty location search is made using the location type and location size.



Machine manufacturer

Please refer to the machine manufacturer's specifications.

Procedure

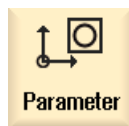

1. Select the "Parameter" operating area.



2. Press the "Tool list", "Tool wear" or "Magazine" softkey.

...





3. Press the ">>" and "Search" softkeys.

...



4. Press the "Tool" softkey if you wish to search for a specific tool.

- OR -



Press the "Magazine location" softkey if you wish to search for a specific magazine location or a specific magazine.

- OR -



Press the "Empty location" softkey if you wish to search for a specific empty location.

11.13 Displaying tool details

All of the selected tool parameters are listed in the "Tool Details" window.

The parameters are displayed, sorted according to the following criteria

- Tool data
- Cutting edge data
- Monitoring data

Protection level

You require access level, keyswitch 3 (protection level 4) in order to edit the parameters in the detail window.



Machine manufacturer

Please refer to the machine manufacturer's specifications.

Procedure



1. The tool list, the wear list, the OEM tool list or the magazine is open.

...



2. Position the cursor to the desired tool.



3. If you are in the tool list or in the magazine, press the ">>" and "Details" softkeys.



- OR -

If you are in the wear list or OEM tool list, press the "Details" softkey.



The "Tool Details" window opens.

All of the available tool data is displayed in the list.



4. Press the "Cutting edge data" softkey if you want to display the cutting data.



5. Press the "Monitoring data" softkey if you want to display the monitoring data.

11.14 Displaying all tool details

All of the selected tool parameters are displayed in the "Tool Details - All Parameters" window.

The parameters are displayed, sorted according to the following criteria:

- Tool data
- Cutting edge data
- Monitoring data

Protection level

You require access level, keyswitch 3 (protection level 4) in order to edit the parameters in the detail window.



Machine manufacturer

Please refer to the machine manufacturer's specifications.

Procedure



1. The tool list, the wear list, the OEM tool list or the magazine is open.

...



2. Position the cursor to the desired tool.



3. If you are in the tool list or in the magazine, press the ">>" and "Details" softkeys.



- OR -



If you are in the wear list or OEM tool list, press the "Details" softkey.



4. Press the "Additional details" softkey.
The "Tool Details - All Parameters" window opens.
All of the tool parameters are displayed in the list.

5. Use the scroll bar to display all the parameters in the list.
- OR -



Press the "Tool data", "Cutting edge data" or "Monitoring data" softkey to jump directly to the required parameters in the list.

...



11.15 Changing a tool type

Procedure



1. The tool list, the wear list, the OEM tool list or the magazine is opened.

...



2. Position the cursor in the column "Type" of the tool that you wish to change.



3. Press the <SELECT> key.
The "Tool types - Favorites" window opens.

4. Select the desired tool type in the list of favorites or select using the softkeys "Cutters 100-199", "Drill 200-299", "Grinders 400-499" or "Spec.tool 700-900".

Note: A grinding tool can only be changed into another grinding tool type.



5. Press the "OK" softkey.
The new tool type is accepted and the corresponding icon is displayed in the "Type" column.

11.16 Settings for tool lists

The "Settings" window provides the following options to set the view in the tool lists:

- Display only one magazine in the magazine sorting
 - You limit the display to one magazine. The magazine is displayed with the assigned buffer locations and the not-loaded tools.
 - You use a configuration to specify whether the "Magazine selection" softkey jumps to the next magazine or whether the "Magazine Selection" dialog for changing switches to any magazine.
- Display only spindles in the buffer

In order to display during operation only the spindle location, the remaining locations of the buffer will be hidden.
- Activating the adapter-transformed view
 - The geometry lengths and the operation offsets are displayed transformed in the tool list.
 - The wear lengths and the sum offsets are displayed transformed in the tool wear list.



Machine manufacturer

Please refer to the machine manufacturer's specifications.

References

Further information about configuring the settings are shown in the following reference:

SINUMERIK Operate (IM9) / SINUMERIK 840D sl Commissioning Manual

Procedure



1. Select the "Parameter" operating area.



2. Press the "Tool list", "Tool wear" or "Magazine" softkey.

...



3. Press the "Continue" and "Settings" softkeys.



4. Activate the checkbox for the desired setting.

Managing programs

12.1 Overview

You can access programs at any time via the Program Manager for execution, editing, copying, or renaming.

Programs that you no longer require can be deleted to release their storage space.

NOTICE

Possible interruption when executing from USB FlashDrive

Direct execution from a USB-FlashDrive is not recommended.

There is no protection against contact problems, falling out, breakage through knocking or unintentional removal of the USB-FlashDrive during operation.

Disconnecting it during operation will result in the stopping of the machining and thus to the workpiece being damaged.

Multiple clamping with ShopMill

With ShopMill, you can implement multiple clamping of identical or different workpieces with optimization of the tool series.



Software options

Multiple clamping is only possible with ShopMill programs. You require the "ShopTurn/ShopMill" option for this.

Storage for programs

Possible storage locations are:

- NC
- Local drive
- Network drives
- USB drives
- V24
- FTP drives



Software options

To display the "Local drive" softkey, you require the "Additional HMI user memory on CF card of the NCU" option (not for SINUMERIK Operate on PCU50 or PC/PG).

Data exchange with other workstations

You have the following options for exchanging programs and data with other workstations:

- USB drives (e.g. USB-FlashDrive)
- Network drives
- FTP drive

Choosing storage locations

In the horizontal softkey bar, you can select the storage location that contains the directories and programs that you want to display. In addition to the "NC" softkey, via which the passive file system data can be displayed, additional softkeys can be displayed.

The "USB" softkey is only operational when an external storage medium is connected (e.g. USB-FlashDrive on the USB port of the operator panel).

Displaying PDF and HTML documents

You can display HTML documents as well as PDFs on drives of the program manager (e.g. in the local drive or USB) and via the data tree of the system data.

However, a preview of the documents is only possible for PDFs.

Note

FTP drive

It is not possible to preview documents on the FTP drive.

Structure of the directories

In the overview, the symbols in the left-hand column have the following meaning:

 Directory

 Program

All directories have a plus sign when the program manager is called for the first time.

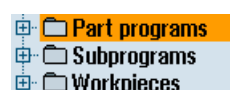

Figure 12-1 Program directory in the program manager

The plus sign in front of empty directories is removed after they have been read for the first time.

The directories and programs are always listed complete with the following information:

- Name

The name can be a maximum of 24 characters long

Permissible characters include all upper-case letters (without accents), numbers, and underscores.

- Type

Directory: WPD

Program: MPF

Subprogram: SPF

Initialization programs: INI

Job lists: JOB

Tool data: TOA

Magazine assignment: TMA

Zero points: UFR

R parameters: RPA

Global user data/definitions: GUD

Setting data: SEA

Protection zones: PRO

Sag: CEC

- Size (in bytes)

- Date/time (of creation or last change)

Active programs

Selected, i.e. active programs are identified using a green symbol.

CHAN1	Name	Type	Length	Date	Time
+	Part programs	DIR		11/30/09	3:49:09 PM
+	Subprograms	DIR		12/02/09	11:24:33 AM
+	Workpieces	DIR		12/02/09	2:53:07 PM
+	DREHEN1	WPD		12/02/09	8:40:58 AM
+	GGG	WPD		12/01/09	12:03:39 PM
+	JOBSHOP_MEHRK	WPD		12/03/09	9:18:27 AM
+	MEHR	WPD		11/30/09	3:49:23 PM
+	MEHRKANAL	WPD		12/02/09	12:47:20 PM
+	SIM_CHESS_KING	WPD		11/30/09	3:49:14 PM
+	SIM_CHESS_LADY_26	WPD		11/30/09	3:49:14 PM
+	SIM_CHESS_TOWER	WPD		11/30/09	3:49:15 PM
+	SIM_ZYK_T_26	WPD		11/30/09	3:49:17 PM
+	SWOB	WPD		12/03/09	8:39:49 AM
+	UT	MPF	205	12/03/09	3:22:48 PM
+	TEMP	WPD		11/30/09	3:49:33 PM

Figure 12-2 Active program shown in green

See also

Multiple clamping (Page 622)

12.1.1 NC memory

The complete NC working memory is displayed along with all tools and the main programs and subroutines.

You can create further subdirectories here.

Proceed as follows



1. Select the "Program manager" operating area.



2. Press the "NC" softkey.

12.1.2 Local drive

Workpieces, main and subprograms that are saved in the user memory of the CF card or on the local hard disk are displayed.

For archiving, you have the option of mapping the structure of the NC memory system or to create a separate archiving system.

You can create any number of subdirectories here, in which you can store any files (e.g. text files with notes).



Software options

To display the "Local drive" softkey, you require the "Additional HMI user memory on CF card of the NCU" option (not for SINUMERIK Operate on PCU50 or PC/PG).

Procedure



1. Select the "Program manager" operating area.



2. Press the "Local drive" softkey.

On the local drive, you have the option of mapping the directory structure of the NC memory. This also simplifies the search sequence.

Creating Directories



1. The local drive is selected.



2. Position the cursor on the main directory.



3. Press the "New" and "Directory" softkeys. The "New Directory" window opens.



4. In the "Name" entry field, enter "mpf.dir", "spf.dir" and "wks.dir" and press the "OK" softkey. The directories "Part programs", "Subprograms" and "Workpieces" are created below the main directory.

12.1.3 USB drives

USB drives enable you to exchange data. For example, you can copy to the NC and execute programs that were created externally.

NOTICE
Interruption of operation
Direct execution from the USB FlashDrive is not recommended, because machining can be undesirably interrupted, therefore resulting in workpiece damage.

Partitioned USB-FlashDrive (only 840D sl and TCU)

If the USB-FlashDrive has several partitions, these are displayed in a tree structure as a subtree (01,02,...).

For EXTCALL calls, enter the partition (e.g. USB:/02/... or //ACTTCU/FRONT/02/... or //ACTTCU/FRONT,2/... or //TCU/TCU1/FRONT/02/...)

You can also configure any partition (e.g. //ACTTCU/FRONT,3).

Procedure



1. Select the "Program manager" operating area.



2. Press the "USB" softkey.

Note

The "USB" softkey can only be operated when a USB-FlashDrive is inserted in the front interface of the operator panel.

12.1.4 FTP drive

The FTP drive offers you the following options - to transfer data, e.g. part programs, between your control system and an external FTP server.

You have the option of archiving any files in the FTP server by creating new directories and subdirectories.

Note

Selecting a program / execution

It is not possible to select a program directly on the FTP drive, and change to execution in the "Machine" operating area.

Precondition

User name and password have been set up in the FTP server.

Procedure



1. Select the "Program manager" operating area.



2. Press the "FTP" softkey.

When selecting the FTP drive for the first time, a login window is displayed.



3. Enter the user name and password and press the "OK" softkey to log into the FTP server.

The content of the FTP server with its folders is displayed.



4. Press the "Log out" softkey after the required data processing has been completed.

The connection to the FTP server is disconnected. In order to reselect the FTP drive, you must log on again.

12.2 Opening and closing the program

To view a program in more detail or modify it, open the program in the editor.

With programs that are in the NCK memory, navigation is already possible when opening. The program blocks can only be edited when the program has been opened completely. You can follow the opening of the program in the dialog line.

With programs that are opened via local network, USB FlashDrive or network connections, navigation is only possible when the program has been opened completely. A progress message box is displayed when opening the program.

Note

Channel changeover in the editor

When opening the program, the editor is opened for the currently selected channel. This channel is used to simulate the program.

If you change over a channel in the editor, this does not influence the editor. Only when closing the editor do you change into the other channel.

Procedure



1. Select the "Program manager" operating area.



2. Select the desired storage location and position the cursor on the program that you would like to edit.
3. Press the "Open" softkey.



- OR -
Press the <INPUT> key.



- OR -
Press the <Cursor right> key.

- OR -
Double-click the program.
The selected program is opened in the "Editor" operating area.
4. Now make the necessary program changes.



5. Press the "NC Select" softkey to switch to the "Machine" operating area and begin execution.



When the program is running, the softkey is deactivated.

Closing the program



Press the ">>" and "Exit" softkeys to close the program and editor again.



- OR -



If you are at the start of the first line of the program, press the <Cursor left> key to close the program and the editor.



To reopen a program you have exited with "Close", press the "Program" key.

Note

A program does not have to be closed in order for it to be executed.

12.3 Executing a program

When you select a program for execution, the controller automatically switches to the "Machine" operating area.

Program selection

Select the workpieces (WPD), main programs (MPF) or subprograms (SPF) by placing the cursor on the desired program or workpiece.

For workpieces, the workpiece directory must contain a program with the same name. This program is automatically selected for execution (e.g. when you select the workpiece SHAFT.WPD, the main program SHAFT.MPF is automatically selected).

If an INI file of the same name exists (e.g. SHAFT.INI), it will be executed once at the first part program start after selection of the part program. Any additional INI files are executed in accordance with machine data MD11280 \$MN_WPD_INI_MODE.

MD11280 \$MN_WPD_INI_MODE=0:

The INI file with the same name as the selected workpiece is executed. For example, when you select SHAFT1.MPF, the SHAFT1.INI file is executed upon <CYCLE START>.

MD11280 \$MN_WPD_INI_MODE=1:

All files of type SEA, GUD, RPA, UFR, PRO, TOA, TMA and CEC which have the same name as the selected main program are executed in the specified sequence. The main programs stored in a workpiece directory can be selected and processed by several channels.



Machine manufacturer

Please refer to the machine manufacturer's specifications.

Procedure



1. Select the "Program Manager" operating area.

2. Select the desired storage location and position the cursor on the workpiece/program that you would like to execute.



3. Press the "Select" softkey.

The controller switches automatically into the "Machine" operating area.
- OR -



If the selected program is already opened in the "Program" operating area,

Press the "Execute NC" softkey.



Press the <CYCLE START> key.

Execution of the workpiece is started.

Note

Only workpieces/programs that are located in the NCK memory, local drive or USB drive can be selected for execution.

12.4 Creating a directory / program / job list / program list

12.4.1 Creating a new directory

Directory structures help you to manage your program and data transparently. You can create subdirectories in a directory on the local drive and on USB/network drives.

In a subdirectory, in turn, you can create programs and then create program blocks for them.

Note

Directory names must end in .DIR or .WPD. The maximum name length is 49 characters including the extension.

All letters (except accented characters), numbers, and underscores are permitted for name assignment. These names are automatically converted to upper-case letters.

This limitation does not apply for work on USB/network drives.

Procedure



1. Select the "Program manager" operating area.



2. Select your chosen storage medium, i.e. a local or USB drive.



3. If you want to create a new directory in the local network, place the cursor on the topmost folder and press the "New" and "Directory" softkeys.



The "New Directory" window opens.



4. Enter the desired directory name and press the "OK" softkey.

12.4.2 Creating a new workpiece

You can set up various types of files such as main programs, initialization files, tool offsets, etc. in a workpiece.

Note

Workpiece directories

You have the option of nesting tool directories. You must note that the length of the call line is restricted. You will be informed if the maximum number of characters is reached when entering the workpiece name.

Procedure



1. Select the "Program manager" operating area.



2. Select the desired storage location and position the cursor on the folder in which you would like to create a workpiece.



3. Press the "New" softkey.
The "New Workpiece" window appears.



4. If necessary, select a template if any are available.
5. Enter the desired workpiece name and press the "OK" softkey.

The name can be a maximum of 24 characters long.

You can use any letters (except accented), digits or the underscore symbol (_).

The directory type (WPD) is set by default.

A new folder with the workpiece name will be created.

The "New G Code Program" window opens.



6. Press the "OK" softkey again if you want to create the program.

The program will open in the editor.

12.4.3 Creating a new G code program

You can create G code programs and then render G code blocks for them in a directory/workpiece.

Procedure



1. Select the "Program manager" operating area.

2. Select the desired storage location and position the cursor on the folder in which you would like to store the program.



3. Press the "New" softkey.



The "New G Code Program" window opens.

4. If necessary, select a template if any are available.
5. Select the file type (MPF or SPF).

If you are in the NC memory and have selected either the "Subprograms" or "Part programs" folder, you can only create one subprogram (SPF) or one main program (MPF).



6. Enter the desired program name and press the "OK" softkey.

Program names can be a maximum of 24 characters long.
You can use all letters (with the exception of special characters, language-specific special characters, Asian or Cyrillic characters), numbers and underscores (_).

12.4.4 Creating a new ShopMill program

In the part program and workpiece directories, you can create ShopMill programs and then subsequently generate the machining steps for them.

Procedure



1. Select the "Program manager" operating area.



2. Select the desired storage location and position the cursor on the folder in which you would like to store the program.
3. Press the "New" softkey.



4. Press the "ShopMill" softkey.
The "New Step Sequence Program" window opens.
The "ShopMill" type is specified.



5. Enter the desired program name and press the "OK" softkey.

Program names can be a maximum of 24 characters long.
You can use all letters (with the exception of special characters, language-specific special characters, Asian or Cyrillic characters), numbers and underscores (_).

12.4.5 Storing any new file

In each directory or subdirectory you can create a file in any format that you specify.

Note

File extensions

In the NC memory, the extension must have 3 characters, and DIR or WPD are not permitted.

In the NC memory, you can create the following file types under a workpiece using the "Any" softkey.

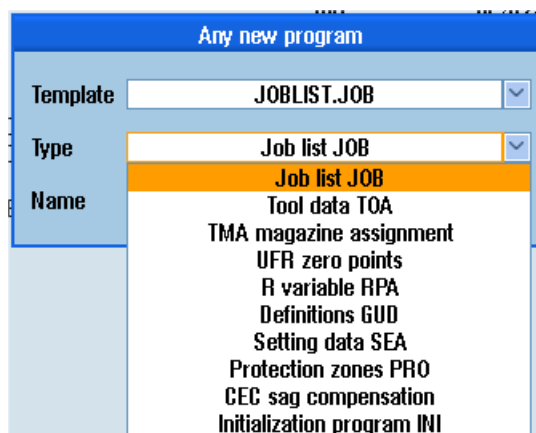

Procedure



1. Select the "Program manager" operating area.



2. Select the desired storage location and position the cursor on the folder in which you would like to create the file.
3. Press the "New" and "Any" softkeys.
The "Any New Program" window appears

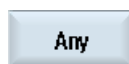

4. Select a file type from the "Type" selection field (for example, "Definitions GUD") and enter the name of the file to be created when you have selected a workpiece directory in the NC memory.
The file automatically has the selected file format.
- OR -

Enter a name and file format for the file to be created (e.g. My_Text.txt).

The name can be a maximum of 24 characters long.

You can use any letters (except accented), digits or the underscore symbol (_).



5. Press the "OK" softkey.

12.4.6 Creating a job list

For every workpiece, you can create a job list for extended workpiece selection.

In the job list, you specify instructions for program selection in different channels.

Syntax

The job list contains the SELECT instructions.

SELECT <program> CH=<channel number> [DISK]

The SELECT instruction selects a program for execution in a specific NC channel. The selected program must be loaded into the working memory of the NC. The DISK parameter enables the selection of external execution (CF card, USB data carrier, network drive).

- <Program>

Absolute or relative path specification of the program to be selected.

Examples:

- //NC/WCS.DIR/SHAFT.WPD/SHAFT1.MPF
- SHAFT2.MPF

- <Channel number>

Number of the NC channel in which the program is to be selected.

Example:

CH=2

- [DISK]

Optional parameter for programs that are not in the NC memory and are to be executed "externally".

Example:

SELECT //remote/myshare/shaft3.mpf CH=1 DISK

Comment

Comments are identified in the job list by ";" at the start of the line or by round brackets.

Template

You can select a template from Siemens or the machine manufacturer when creating a new job list.

Executing a workpiece

If the "Select" softkey is selected for a workpiece, the syntax of the associated job list is checked and then executed. The cursor can also be placed on the job list for selection.

Procedure

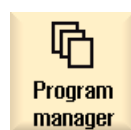

1. Select the "Program manager" operating area.



2. Press the "NC" softkey, and in directory "Workpieces" place the cursor on the program for which you wish to create a job list.



3. Press the "New" and "Any" softkeys.
The "Any New Program" window opens.



4. Select entry "Job list JOB" from the "Type" selection field and enter a name and press the "OK" softkey.

12.4.7 Creating a program list

You can also enter programs in a program list that are then selected and executed from the PLC.

The program list may contain up to 100 entries.



Machine manufacturer

Please refer to the machine manufacturer's specifications.

Procedure



1. Select the "Program manager" operating area.



2. Press the menu forward key and the "Program list" softkey.
The "Prog.-list" window opens.



3. Place the cursor in the desired line (program number).



4. Press the "Select program" softkey.

The "Programs" window opens. The data tree of the NC memory with workpiece, part program and subprogram directory is displayed.



5. Place the cursor on the desired program and press the "OK" softkey.
The selected program is inserted in the first line of the list together with its path.

- OR -

Enter the program name directly in the list.

If you are making entries manually, check that the path is correct (e.g. //NC/WKS.DIR/MEINPROGRAMM.WPD/MEINPROGRAMM.MPF).

//NC and the extension (.MPF) may be added automatically.

With multi-channel machines, you can specify in which channel the program is to be selected.



6. To remove a program from the list, place the cursor on the appropriate line and press the "Delete" softkey.

- OR -



To delete all programs from the program list, press the "Delete all" softkey.

12.5 Creating templates

You can store your own templates to be used for creating part programs and workpieces. These templates provide the basic framework for further editing.

You can use them for any part programs or workpieces you have created.

Storage location for templates

The templates used to create part programs or workpieces are stored in the following directories:

HMI Data/Templates/Manufacturer/Part programs or Workpieces

HMI Data/Templates/User/Part programs or Workpieces

Procedure



1. Select the "Start-up" operating area.



2. Press the "System data" softkey.



3. Position the cursor on the file that you wish to store as a template and press the "Copy" softkey.



4. Select the directory in which you want to store the data - "Part programs" or "Workpieces" - and press the "Paste" softkey.

Stored templates can be selected when a part program or a workpiece is being created.

12.6 Searching directories and files

You have the possibility of searching in the Program Manager for certain directories and files.

Note

Search with place holders

The following place holders simplify the search:

- "*": replaces any character string
- "?": replaces any character

Search strategy

The search is made in all of the selected directories and their subdirectories.

If the cursor is positioned on a file, then a search is made from the higher-level directory.

Note

Searching in opened directories

Open the closed directories for a successful search.

Procedure



1. Select the "Program Manager" operating area.



2. Select the storage location in which you wish to perform the search and then press the ">>" and "Search" softkeys.



The "Find file" window appears.

3. Enter the desired search term in the "Text" field.

Note: When searching for a file, enter the complete name with extension (e.g. DRILLING.MPF).

4. When required, activate the checkbox "Observe upper and lower case".



5. Press the "OK" softkey to start the search.

6. If a corresponding directory or file is found, then it is marked.



7. Press the "Continue search" and "OK" softkeys if the directory or the file does not correspond to the required result.

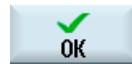

- OR -

Press the "Cancel" softkey when you want to cancel the search.

12.7 Displaying the program in the Preview.

You can show the content on a program in a preview before you start editing.

Procedure



1. Select the "Program manager" operating area.



2. Select a storage location and place the cursor on the relevant program.
3. Press the ">>" and "Preview window" softkeys.
The "Preview: ..." window opens.



4. Press the "Preview window" softkey again to close the window.

12.8 Selecting several directories/programs

You can select several files and directories for further processing. When you select a directory, all directories and files located beneath it are also selected.

Note

Selected files

If you have selected individual files in a directory, then this selection is canceled when the directory is closed.

If the complete directory with all of the files included in it are selected, then this selection is kept when closing the directory.

Procedure



1. Select the "Program manager" operating area.



2. Choose the desired storage location and position the cursor on the file or directory from which you would like your selection to start.
3. Press the "Select" softkey.



The softkey is active.







4. Select the required directories/programs with the cursor keys or mouse.
5. Press the "Select" softkey again to deactivate the cursor keys.



Canceling a selection

By reselecting an element, the existing selection is canceled.

Selecting via keys

Key combination	Meaning
 SELECT	Renders or expands a selection. You can only select individual elements.
 SHIFT  	Renders a consecutive selection.
 INSERT	A previously existing selection is canceled.

Selecting with the mouse

Key combination	Meaning
Left mouse	Click on element: The element is selected. A previously existing selection is canceled.
Left mouse +  SHIFT Pressed	Expand selection consecutively up to the next click.
Left mouse +  CTRL Pressed	Expand selection to individual elements by clicking. An existing selection will expand to include the element you clicked.

12.9 Copying and pasting a directory/program

To create a new directory or program that is similar to an existing program, you can save time by copying the old directory or program and only changing selected programs or program blocks.

The capability of copying and pasting directories and programs can also be used to exchange data with other systems via USB/network drives (e.g. USB FlashDrive).

Copied files or directories can be pasted in a different location.

Note

You can only paste directories on local drives and on USB or network drives.

Note

Write protection

If the current directory is write-protected for the user, then the function is not offered.

Note

When you copy directories, any missing endings are added automatically.

All letters (except accented characters), numbers, and underscores are permitted for name assignment. The names are automatically converted to upper-case letters, and extra dots are converted to underscores.

Example

If the name is not changed during the copy procedure, a copy is created automatically:

MYPROGRAM.MPF is copied to MYPROGRAM__1.MPF. The next time it is copied, it is changed to MYPROGRAM__2.MPF, etc.

If the files MYPROGRAM.MPF, MYPROGRAM__1.MPF, and MYPROGRAM__3.MPF already exist in a directory, MYPROGRAM__2.MPF is created as the next copy of MYPROGRAM.MPF.

Procedure



1. Select the "Program manager" operating area.



2. Choose the desired storage location and position the cursor on the file or directory which you would like to copy.



3. Press the "Copy" softkey.

4. Select the directory in which you want to paste your copied directory/program.

5. Press the "Paste" softkey.

If a directory/program of the same name already exists in this directory, you are informed. You are requested to assign a new name, otherwise the directory/program is assigned a name by the system.

If the name contains illegal characters or is too long, a prompt will appear for you to enter a permissible name.



6. Press the "OK" or "Overwrite all" softkey if you want to overwrite existing directories/programs.



- OR -



Press the "No overwriting" softkey if you do not want to overwrite already existing directories/programs.

- OR -



Press the "Skip" softkey if the copy operation is to be continued with the next file.

- OR -



Enter another name if you want to paste the directory/program under another name and press the "OK" softkey.

Note

Copying files in the same directory

You cannot copy files to the same directory. You must copy the file under a new name.

12.10 Deleting a program/directory

12.10.1 Deleting a program/directory

Delete programs or directories from time to time that you are no longer using to maintain a clearer overview of your data management. Back up the data beforehand, if necessary, on an external data medium (e.g. USB FlashDrive) or on a network drive.

Please note that when you delete a directory, all programs, tool data and zero point data and subdirectories that this directory contains are deleted.

Temp directory for ShopMill

If you want to free up space in the NCK memory, delete the contents of the "TEMP" directory. ShopMill stores the programs that are created internally for calculating the stock removal processes in this directory.

Procedure



1. Select the "Program manager" operating area.



2. Choose the desired storage location and position the cursor on the file or directory that you would like to delete.

3. Press the ">>" and "Delete" softkeys.

A prompt appears as to whether you really want to delete the file or directory.

4. Press the "OK" softkey to delete the program/directory.

- OR -.



Press the "Cancel" softkey to cancel the process.

12.11 Changing file and directory properties

Information on directories and files can be displayed in the "Properties for ..." window.

Information on the creation date is displayed near the file's path and name.

You can change names.

Changing access rights

Access rights for execution, writing, listing and reading are displayed in the "Properties" window.

- Execute: Is used for the selection for execution
- Write: Controls the changing and deletion of a file or a directory

For NC files, you have the option to set the access rights from keyswitch 0 to the current access level, to be set separately for each file.

If an access level is higher than the current access level, it cannot be changed.

For external files (e.g. on a local drive), the access rights are displayed to you only if settings have been executed for these files by the machine manufacturer. They cannot be changed via the "Properties" window.

Settings for the access rights to directories and files

Via a configuration file and MD 51050, access rights of the directories and file types of the NC and user memory (local drive) can be changed and pre-assigned.

References

A detailed description of the configuration can be found in the following documentation:

Commissioning Manual SINUMERIK Operate (IM9) / SINUMERIK 840D sl

Procedure



1. Select the program manager.



2. Choose the desired storage location and position the cursor on the file or directory whose properties you want to display or change.





3. Press the ">>" and "Properties" softkeys.
The "Properties from ..." window appears.

...



4. Enter any necessary changes.
Note: You can save changes via the user interface in the NC memory.



5. Press the "OK" softkey to save the changes.

12.12 Set up drives

12.12.1 Overview

Up to eight connections to so-called logical drives (data carriers) can be configured. These drives can be accessed in the "Program manager" and "Startup" operating areas.

The following logical drives can be set up:

- USB interface
- CompactFlash card of the NCU, only for SINUMERIK Operate in the NCU
- Network drives
- Local hard disk of the PCU, only for SINUMERIK Operate on the PCU



Software option

In order to use the CompactFlash card as data carrier, you require the "Additional HMI user memory on CF card of the NCU" option (not for SINUMERIK Operate on PCU or PC).

Note

The USB interfaces of the NCU are not available for SINUMERIK Operate and therefore cannot be configured.

12.12.2 Setting up drives



The "Set Up Drives" window is available in the "Start-up" operating area for configuration.

File

The created configuration data is stored in the "logdrive.ini" file. This file is located in the /user/sinumerik/hmi/cfg directory.

General information

Entry		Meaning
Type	No drive	No drive defined.
	USB local	Access to the USB memory medium is only realized via the TCU to which it is connected. USB drives are automatically identified if the memory medium is inserted when SINUMERIK Operate powers-up.
	USB global	All of the TCUs in the plant network can access the USB memory medium. - USB global is not possible under Windows!
	NW Windows/Linux	Network drive
	Local drive	Local drive Hard disk or user memory on the CompactFlash card.
	FTP	Access to an external FTP server.
Connection	Front	USB interface that is located at the front of the operator panel.
	X203/X204	USB interface X203/X204 that is located at the rear of the operator panel.
	X204	For SIMATIC Thin Client the USB interface is X204.
Device		Names of the TCU to which the USB storage medium is connected, e.g. tcu1. The NCU must already know the TCU name.
Partition		Partition number on the USB memory medium, e.g. 1. If a USB hub is used, specify the USB port of the hub.
Port		Interface for the FTP connection. The default port is 21.
Disconnect		After a disconnect timeout, the FTP connection is disconnected. The timeout can be between 1 and 150 s. 10 s is the default setting.
Path		<ul style="list-style-type: none"> Start direct directory of the data carrier that is connected via the local drive. Network path to a directory that has been released in the network. This path must always start with "//", e.g. //Server01/share3.
Access level		Assign access rights to the connections: From access level 7 (keyswitch position 0) to access level 1 (manufacturer). The particular assigned access level applies to all operating areas.
Softkey text		2 lines are available as labeling text for the softkey. %n is accepted as a line separator. If the first line is too long, then it is automatically separated into several lines. If a blank is present, then this is used as line separator.
Softkey icon	No icon	No icon is displayed on the softkey.

Entry		Meaning
	sk_usb_front.png 	The icon file name displayed on the softkey.
	sk_local_drive.png 	
	sk_network_drive_ftp.png 	
Text file	slpmdialog	File for softkey dependent on the language. If nothing is specified in the input fields, the text appears on the softkey as was specified in the input field "Softkey text". If your own text files are saved, then the text ID, which is used to search for the text file, is specified in the "Softkey text" input field.
Text context	SIPmDialog	
User name Password		Enter the user name and the corresponding password for which the directory is enabled on the server. The password is displayed in encoded form as string of "*" characters and is stored in the "logdrive.ini" file.

Error messages

Error message	Meaning
Error occurred when closing a connection.	An existing drive was not able to be deactivated.
Error occurred when establishing a connection.	Drive connection was not able to be established.
Error occurred while establishing a connection: Incorrect entry or no authorization.	Drive connection was not able to be established.
Incorrect data	The entered data is either incorrect or inconsistent.
Function not available	The function is not supported with the current software release.
Unknown error - error code:%1	Error was not able to be assigned.

Procedure

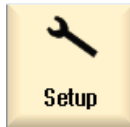

1. Select the "Start-up" operating area.



2. Press the "HMI" and "Log. drive" softkeys.
The "Set Up Drives" window opens.



3. Select the data for the corresponding drive or enter the necessary data.
4. Press the "Activate drive" softkey.
The drive is activated.

The operating system now checks the entered data and whether the connection is established. An OK message is output in the dialog line if an error is not identified.

The drive can be accessed.

- OR -

If the operating system identifies an error, then you receive an error message.



Press the "OK" softkey.

You then return to the "Set Up Drives" window. Check and correct your entries and re-activate the drive.



If you press the "OK" softkey, the modified data is accepted without any feedback message. You do not receive any message about a successful or unsuccessful connection.



If you press the "Cancel" softkey, then all of the data that has not been activated is rejected.

12.13 Viewing PDF documents

You have the option of displaying HTML documents, as well as PDFs, on all drives of the program manager via the data tree of the system data.

Note

A preview of the documents is only possible for PDFs.

Procedure



1. In the "Program manager" operating area, select the desired storage medium.

- OR -
Select the desired storage location in the "Commissioning" operating area in the data tree of the "System data".
2. Position the cursor on the PDF or the HTML file that you want to display, and press the "Open" softkey.
The selected file is displayed on the screen.
The storage path of the document is displayed in the status bar. The current page as well as the total number of pages of the document are displayed.
3. Press the "Zoom +" or "Zoom -" softkey to enlarge or reduce the size of the display.
4. Press the "Search" softkey if you want to search for specific texts in the PDF.
5. Press the "View" softkey to change the representation of the PDF.
A new vertical softkey bar appears.
6. Press the "Zoom page width" softkey to display the document in full width on the screen.

- OR -
Press the "Zoom page height" softkey to display the document with full height on the screen.

- OR -
Press the "Rotate left" softkey to rotate the document through 90 degrees to the left.

- OR -



Press the "Rotate right" softkey to rotate the document through 90 degrees to the right.



7. Press the "Back" softkey to return to the previous window.

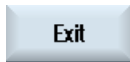

8. Press the "Close" softkey to exit the PDF display.

12.14 EXTCALL

The EXTCALL command can be used to access files on a local drive, USB data carriers or network drives from a part program.

The programmer can set the source directory with the setting data SD \$SC42700 EXT_PROG_PATH and then specify the file name of the subprogram to be loaded with the EXTCALL command.

Supplementary conditions

The following supplementary conditions must be taken into account with EXTCALL calls:

- You can only call files with the MPF or SPF extension via EXTCALL from a network drive.
- The files and paths must comply with the NCK naming conventions (max. 25 characters for the name, 3 characters for the identifier).
- A program is found on a network drive with the EXTCALL command if
 - with SD \$SC42700 EXT_PROG_PATH the search path refers to the network drive or a directory contained on the network drive. The program must be stored directly on that level, no subdirectories are searched.
 - without SD \$SC42700 the correct location of the program is specified in the EXTCALL call itself by means of a fully qualified path that can also point to a subdirectory of the network drive.
- For programs that were generated on external storage media (Windows system) observe upper- and lower-case syntax.

Note

Maximum path length for EXTCALL

The path length must not exceed 112 characters. The path comprises the contents of the setting data (SD \$SC42700) and the path data for EXTCALL call from the part program.

Examples of EXTCALL calls

The setting data can be used to perform a targeted search for the program.

- Call of USB drive on TCU (USB storage device on interface X203), if SD42700 is empty:
e.g. EXTCALL "//TCU/TCU1 /X203 ,1/TEST.SPF"

- OR -

Call of USB drive on TCU (USB storage device on interface X203), if SD42700
"//TCU/TCU1 /X203 ,1" contains: EXTCALL "TEST.SPF"

- Call of the USB front connection (USB-FlashDrive), if SD \$SC 42700 is empty: e.g.
EXTCALL "//ACTTCU/FRONT,1/TEST.SPF"

- OR -

Call of USB front connection (USB-FlashDrive), if SD42700 "//ACTTCU/FRONT,1"
contains: EXTCALL "TEST.SPF"

- Call of network drive, if SD42700 is empty: e.g. EXTCALL "//computer name/enabled
drive/TEST.SPF"

- OR -

Call of the network drive, if SD \$SC42700 "//Computer name/enabled drive" contains:
EXTCALL "TEST.SPF"

- Use of the HMI user memory (local drive):

- On the local drive, you have created the directories part programs (mpf.dir),
subprograms (spf.dir) and workpieces (wks.dir) with the respective workpiece
directories (.wpc):

SD42700 is empty: EXTCALL "TEST.SPF"

The same search sequence is used on the CompactFlash card as in the NCK part
program memory.

- On the local drive, you have created your own directory (e.g. my.dir):

Specification of the complete path: e.g. EXTCALL
"/card/user/sinumerik/data/prog/my.dir/TEST.SPF"

A search is performed for the specified file.

Note

Abbreviations for local drive, CompactFlash card and USB front connection

As abbreviation for the local drive, the CompactFlash card and the USB front
connection you can use the abbreviation LOCAL_DRIVE:, CF_CARD: and USB: (e.g.
EXTCALL "LOCAL_DRIVE:/spf.dir/TEST.SPF").

Alternatively, you can also use the abbreviations CF_Card and LOCAL_DRIVE.



Software options

To display the "Local drive" softkey, you require the "Additional HMI user memory on CF card of the NCU" option (not for SINUMERIK Operate on PCU50 / PC).

NOTICE

Possible interruption when executing from USB FlashDrive

Direct execution from a USB-FlashDrive is not recommended.

There is no protection against contact problems, falling out, breakage through knocking or unintentional removal of the USB-FlashDrive during operation.

Disconnecting it during operation will result in immediate stopping of the machining and, thus, to the workpiece being damaged.



Machine manufacturer

Processing EXTCALL calls can be enabled and disabled.

Please refer to the machine manufacturer's specifications.

12.15 Backing up data

12.15.1 Generating an archive in the Program Manager

You have the option of archiving individual files from the NC memory and the local drive.

Archive formats

You have the option of saving your archive in the binary and punched tape format.

Save target

The archive folder of the system data in the "Startup" operating area as well as USB and network drives are available as save target.

Procedure



1. Select the "Program Manager" operating area.



2. Select the storage location for the file/files to be archived.

3. In the directories, select the required file from which you want to create an archive.

- OR -



If you want to back up several files or directories, press the "Select" softkey and, using the cursor keys or the mouse, select the required directories or files.



4. Press the ">>" and "Archive" softkeys.



5. Press the "Generate archive" softkey.

The "Generate Archive: Select archiving" window opens.



6. Position the cursor to the required storage location, press the "Search" softkey, enter the required search term in the search dialog and press the "OK" softkey if you wish to search for a specific directory or subdirectory.



Note: The place holders "" (replaces any character string) and "?" (replaces any character) make it easier for you to perform a search.

- OR -



Select the required storage location, press the "New directory" softkey, enter the required name in the "New directory" window and press the "OK" softkey to create a directory.



7. Press "OK".
The "Generate Archive: Name" window opens.

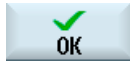

9. Select the format (e.g. archive ARC (binary format)), enter the desired name and press the "OK" softkey.
A message informs you if archiving was successful.

12.15.2 Generating an archive via the system data

If you only want to backup specific data, then you can select the desired files directly from the data tree and generate an archive.

Archive formats

You have the option of saving your archive in the binary and punched tape format.

You can display the contents of the selected files (XML, ini, hsp, syf files, programs) in a preview.

You can display information about the file, such as path, name, date of creation and change, in a Properties window.

Precondition

The access rights depend on the relevant areas and range from protection level 7 (key switch position 0) to protection level 2 (password: Service).

Storage locations

- CompactFlash card under
 /**user**/sinumerik/data/archive, or
 /**oem**/sinumerik/data/archive
- All configured logical drives (USB, network drives)



Software option

In order to save archives on the CompactFlash card in the user area you require the option "Additional HMI user memory on CF card of NCU".

NOTICE

Possible data loss when using USB flash drives

USB-FlashDrives are not suitable as persistent memory media.

Procedure



1. Select the "Startup" operating area.



2. Press the "System data" softkey.

The data tree opens.

3. In the data tree, select the required files from which you want to generate an archive.

- OR -



If you want to back up several files or directories, press the "Select" softkey and, using the cursor keys or the mouse, select the required directories or files.



4. If you press the ">>" softkey, further softkeys are displayed on the vertical bar.



5. Press the "Preview window" softkey.

The contents of the selected file are displayed in a small window. Press the "Preview window" softkey again to close the window.



6. Press the "Properties" softkey.

Information about the selected file is displayed in a small window. Press the "OK" softkey to close the window.



7. Press the "Search" softkey.



Enter the required search term in the search dialog and press the "OK" softkey if you wish to search for a specific directory or subdirectory.

Note: The place holders "*" (replaces any character string) and "?" (replaces any character) make it easier for you to perform a search.



8. Press the "Archive" and "Generate archive" softkeys.



The "Generate Archive: Select Storage Location" window opens.



The "Archive" folder with the subfolders "User" and "Manufacturer" as well as the storage media (e.g. USB) are displayed.



9. Select the required location for archiving and press the "New directory" softkey to create a suitable subdirectory.

The "New Directory" window opens.



10. Enter the required name and press the "OK" softkey.

The directory is created below the selected folder.



11. Press the "OK" softkey.

The "Generate Archive: Name" window opens.



12. Select the format (e.g. archive ARC (binary format)), enter the desired name and press the "OK" softkey to archive the file/files.

A message informs you if archiving was successful.



13. Press the "OK" softkey to confirm the message and end the archiving operation.

An archive file in .arc format is created in the selected directory.

12.15.3 Reading in an archive in the Program Manager

In the "Program Manager" operating area, you have the option of reading in archives from the archive folder of the system data as well as from configured USB and network drives.



Software option

In order to read-in user archives in the "Program Manager" operating area, you require the option "Additional HMI memory on CF Card of NCU" (not for SINUMERIK Operate on PCU50 / PC).

Procedure



1. Select the "Program Manager" operating area.



2. Press the "Archive" and "Read in archive" softkeys.

The "Read in archive: Select archive" window opens.



3. Select the archive storage location and position the cursor on the required archive.

Note: When the option is not set, the folder for user archives is only displayed if the folder contains at least one archive.

- OR -

Press the "Search" softkey and in the search dialog, enter the name of the archive file with file extension (*.arc) if you wish to search for a specific archive and press the "OK" softkey.



...



4. Press the "OK" or "Overwrite all" softkey to overwrite existing files.

- OR -

Press the "Do not overwrite" softkey if you do not want to overwrite already existing files.

- OR -

Press the "Skip" softkey if the read-in operation is to be continued with the next file.

The "Read In Archive" window opens and a progress message box appears for the read-in process.

You will then obtain a "Read error log for archive" in which the skipped or overwritten files are listed.



5. Press the "Cancel" softkey to cancel the read-in process.

See also

Searching directories and files (Page 590)

12.15.4 Read in archive from system data

If you want to read in a specific archive, you can select this directly from the data tree.

Procedure



1. Select the "Start-up" operating area.



2. Press the "System data" softkey.

3. In the data tree below the "Archive" directory, in the "User" folder, select the file that you wish to read in.



4. Press the "Read in" softkey.

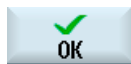

5. Press the "OK" or "Overwrite all" softkey to overwrite existing files.

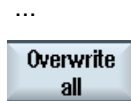

- OR -

Press the "Do not overwrite" softkey if you do not want to overwrite already existing files.

- OR -

Press the "Skip" softkey if the read-in operation is to be continued with the next file.



The "Read In Archive" window opens and a progress message box appears for the read-in process.

You will then obtain a "Read error log for archive" in which the skipped or overwritten files are listed.



6. Press the "Cancel" softkey to cancel the read-in process.

12.16 Setup data

12.16.1 Backing up setup data

Apart from programs, you can also save tool data and zero point settings.

You can use this option, for example, to back up tools and zero point data for a specific machining step program. If you want to execute this program at a later point in time, you will then have quick access to the relevant settings.

Even tool data that you have measured on an external tool setting station can be copied easily into the tool management system using this option.

Backing-up job lists

If you wish to backup a job list, which contains ShopMill and G code programs, you obtain dedicated selection boxes to backup the tool data and zero points.

Note

Backing up setup data from part programs

Setup data from part programs can only be backed up if they have been saved in the "Workpieces" directory.

For part programs, which are located in the "Part programs" directory, "Save setup data" is not listed.

Backing up data

Data	
Tool data	<ul style="list-style-type: none"> • No • All used in the program (only for ShopMill program and job list with ShopMill programs) • Complete tool list
Tool data for ShopMill programs -- only available for job list with ShopMill and G code programs	<ul style="list-style-type: none"> • No • All used in the program • Complete tool list
Tool data for G code programs -- only available for job list with ShopMill and G code programs	<ul style="list-style-type: none"> • No • Complete tool list
Magazine assignment	<ul style="list-style-type: none"> • Yes • No

Data	
Zero points	<ul style="list-style-type: none"> • No The selection box "Basis zero point" is hidden • All used in the program (only for ShopMill program and job list with ShopMill programs) • All
Zero points for ShopMill programs -- only available for job list with ShopMill and G code programs	<ul style="list-style-type: none"> • No The selection box "Basis zero point" is hidden • All used in the program • Complete tool list
Zero points for G code programs -- only available for job list with ShopMill and G code programs	<ul style="list-style-type: none"> • No The selection box "Basis zero point" is hidden • All
Basic zero points	<ul style="list-style-type: none"> • No • Yes
Directory	The directory is displayed, in which the selected program is located.
File name	Here you have the option of changing the suggested file names.

Note

Magazine assignment

You can only read out the magazine assignments if your system provides support for loading and unloading tool data to and from the magazine.

Procedure



1. Select the "Program Manager" operating area.



2. Position the cursor on the program whose tool and zero point data you wish to back up.

...



3. Press the ">>" and "Archive" softkeys.



4. Press the "Setup data" softkey.
The "Backup setup data" window opens.



5. Select the data you want to back up.
6. When required, change the specified name of the originally selected program here in the "File name" field.



7. Press the "OK" softkey.
The setup data will be set up in the same directory in which the selected program is stored.
The file is automatically saved as INI file.

Note

Program selection

If a main program as well as an INI file with the same name are in a directory, when selecting the main program, initially, the INI file is automatically started. In this way, unwanted tool data can be changed.



Machine manufacturer

Please refer to the machine manufacturer's specifications.

12.16.2 Reading-in set-up data

When reading-in, you can select which of the backed-up data you wish to read-in:

- Tool data
- Magazine assignment
- Zero points
- Basic zero point

Tool data

Depending on which data you have selected, the system behaves as follows:

- Complete tool list

First, all tool management data are deleted and then the saved data are imported.

- All tool data used in the program

If at least one of the tools to be read in already exists in the tool management system, you can choose between the following options.



Select the "Replace all" softkey to import all tool data. Any existing tools will now be overwritten without a warning prompt.

- OR -



Press the "Do not overwrite" softkey if existing tools must not be overwritten.

Already existing tools are skipped, without you receiving any queries.

- OR -



Press the "Skip" softkey if already existing tools are not to be overwritten.

For an already existing tool, you receive a query.

Selecting loading point

For a magazine, if more than one loading point was set-up, using the "Select loading point" softkey, you have the option of opening a window in which you can assign a loading point to a magazine.

Procedure



1. Select the "Program Manager" operating area.

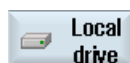

2. Position the cursor on the file with the backed-up tool and zero point data (*.INI) that you wish to re-import.



3. Press the <Cursor right> key

- OR -

Double-click the file.

The "Read-in setup data" window opens.



4. Select the data (e.g. magazine assignment) that you wish to read-in.



5. Press the "OK" softkey.

12.17 RS-232-C

12.17.1 Reading-in and reading-out archives

Availability of the RS-232-C serial interface

You have the option of reading-out and reading-in archives in the "Program manager" operating area as well as in the "Start-up" operating area via the RS-232-C serial interface.

- SINUMERIK Operate on the NCU:

The softkeys for the RS-232-C are available as soon as an option module is connected and the slot is occupied.

- SINUMERIK Operate on the PCU:

The softkeys for the RS-232-C are always available.

Reading-out archives

The files to be sent (directories or individual files) are zipped in an archive (*.ARC). If you send an archive (*.arc), this is sent directly without being additionally zipped. If you have selected an archive (*.arc) together with an additional file (e.g. directory), then these are zipped into a new archive and are then sent.

Reading-in archives

Only archives can be read-in via the RS-232-C. These are transferred and then subsequently unzipped.

Note

Start-up archive

If you read in a start-up archive via the RS-232-C, then this is immediately activated.

Externally processing the punched tape format

If you wish to externally process an archive, then generate this in the punched tape format. Using the SinuCom commissioning and service tool SinuCom ARC, you can process the archive in the binary format and in the commissioning archive.

Procedure

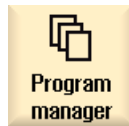

1. Select the "Program manager" operating area, and press the "NC" or "Local drive" softkey.



...



- OR -



- Select the "Start-up" operating area and press the "System data" softkey.



Reading-out archives

2. Select the directories or the files that you wish to send via RS-232-C.
3. Press the ">>" and "Archive" softkeys.



4. Press the "RS-232-C send" softkey.



- OR -

Reading in an archive









- Press the "RS-232-C receive" softkey if you wish to read-in files via RS-232-C.

12.17.2 Setting V24 in the program manager

V24 setting	Meaning
Protocol	The following protocols are supported for transfer via the V24 interface: <ul style="list-style-type: none"> • RTS/CTS (default setting) • Xon/Xoff
Transfer	It is also possible to use a secure protocol for data transfer (ZMODEM protocol). <ul style="list-style-type: none"> • Normal (default setting) • secure For the selected interface, secure data transfer is set in conjunction with handshake RTS/CTS.
Baud rate	Transfer rate: Transfer rates of up to 115 kbaud can be selected. The baud rate that can be used depends on the connected device, the cable length and the general electrical conditions. <ul style="list-style-type: none"> • 110 • • 19200 (default) • ... • 115200
Archive format	<ul style="list-style-type: none"> • Punched tape format (default setting) • Binary format (PC format)
V24 settings (details)	
Interface	<ul style="list-style-type: none"> • COM1
Parity	Parity bits are used for error detection: The parity bits are added to the coded characters to make the number of positions set to "1" an uneven number (uneven parity) or to an even number (even parity). <ul style="list-style-type: none"> • None (default setting) • Odd • Even
Stop bits	Number of stop bits for asynchronous data transfer. <ul style="list-style-type: none"> • 1 (default) • 2
Data bits	Number of data bits for asynchronous data transfer. <ul style="list-style-type: none"> • 5 bits • ... • -8 bits (default setting)
XON (hex)	Only for punched tape format
XOFF (hex)	Only for punched tape format

V24 setting	Meaning
End of data transfer (hex)	Only for punched tape format Stop with end of data transfer character The default setting for the end of data transfer character is (HEX) 1A
Time monitoring (sec)	Time monitoring For data transfer problems or at the end of data transfer (without end of data transfer character) data transfer is interrupted after the specified number of seconds. The time monitoring is controlled by a time generator (clock) that is started with the first character and is reset with each transferred character. The time monitoring can be set (seconds).

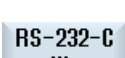
Procedure

- 
1. Select the "Program Manager" operating area.
- 
2. Press the "NC" or "Local drive" softkey.
- 
3. Press the ">>" and "Archive" softkeys.
- 
4. Select the "V24 settings" softkey.
- 
5. The "Interface: V24" window is opened.
- 
6. The interface settings are displayed.
- 
6. Press the "Details" softkey if you wish to view and process additional settings for the interface.

12.18 Multiple clamping

12.18.1 Multiple clamping

The "Multiple clamping" function optimizes tool changes over several workpiece clampings. This shortens idle times because a tool performs all machining operations in all clampings before the next tool change is initiated.



Software options

Multiple clamping is only possible with ShopMill programs. You require the "ShopTurn/ShopMill" option for this.

You can use not only the surface clampings but also the "multiple clamping" function for rotating fixture plates. For this, the machine must have an additional rotary axis (e.g. A-axis) or a dividing unit.



Machine manufacturer

Please refer to the machine manufacturer's specifications.

You can machine not only identical but also different workpieces.

ShopMill automatically generates a single program out of several programs. The tool sequence within a program remains unchanged. Cycles and subprograms are not opened, position patterns are processed as closed units.

Requirements

The individual programs must meet the following requirements:

- Only sequence programs (not G code programs)
- Programs must be executable
- Program for the 1st clamping must have been trial run
- No markers/repetitions, i.e. no branches in the program
- No inch/metric switchover
- No work offsets (except ShopMill program header)
- No coordinate transformation (translation, scaling, etc.)
- Contours must have unique names, i.e. the same contour name must not be called in several different programs.
- The "Starting point" parameter must not be set to "manual" in the stock removal cycle (contour milling).
- No modal settings, i.e. settings that are effective for all subsequent program blocks (only with multiple clamping for different programs)

- 3500 operating steps max. per clamping
- Max. 49 clampings

Note

You can substitute subprograms for the markers or repetitions which must not be included in programs for multiple clampings.

12.18.2 Program header setting, "Clamping"

During the generation of a multiple clamping program, data from the program header of a source program are transferred to a settings step of the multiple clamping program after every clamping change. The setting of the clamping in the program header is also part of this data. The clamping in the program header designates the name of the rotary axis in which the blank is clamped.

A distinction is made between the multiple clamping programs:

- Program type 1, in which the same program is assigned to several clampings.
- Program type 2, in which a different program is assigned to each clamping.

A distinction is made between the installations:

- Installation type A, in which all clampings of the multiple clamping are mounted on one table or on one rotary axis.
- Installation type B, in which the clampings are distributed over different rotary axes (rotary tables).

Multiple clamping programs of program type 1 cannot be executed on installations of type B and are therefore not permitted.

Reason:

The program header contains the axis name of one clamping. Since this axis name is entered in each setting step at a clamping change, the assignment to the actual rotary axis of the respective clamping is missing in the generated multiple clamping program.

Example:

The installation has two rotary tables C1 and C2. The same blank is clamped on both tables. Both blanks are to be machined with the same program. The rotary table must be addressed for the machining.

The original program designates clamping C1 in the program header. The resulting multiple clamping program uses the axis name C1 for both rotary tables, because the other axis name is not known to the program.

The other combinations of multiple clamping programs and installation types are permitted and supported.



Machine manufacturer

Please refer to the machine manufacturer's specifications.

See also

Program header (Page 259)

12.18.3 Creating a multiple clamping program

When assigning the ShopMill programs to a multiple clamping program, you can use programs from NC directories and from external storage media (e.g. USB-FlashDrive).

Procedure



1. Select the "Program manager" operating area.



2. Press the ">>" and "Multiple clamping" softkeys.
The "Multiple Clamping" window opens.



3. Enter the number of clampings and the number of the first zero offset to be used.
The clampings are processed in ascending order from the start zero offset.



4. Enter a name for the new global program (e.g. XYZ) and press the "OK" softkey.
A list is displayed in which the different programs must be assigned to the zero offsets. Not all zero offsets, i.e. clampings, must be assigned to ShopMill programs, but at least two.

5. Enter the name of the desired ShopMill program directly in the list with the complete path specification. The file format (*.mpf) is automatically added.

- OR -



Press the "Program selection" softkey.
The program view is displayed.



6. Position the desired ShopMill program in the program overview and press the "OK" softkey.



- OR -

If you wish to execute the same program on all clampings, press the "On all clampings" softkey.

You can assign different programs to individual zero offsets first, and then assign one program to the remaining zero offsets by selecting the "On all clampings" softkey.

The program is included in the assignment list.

Assigned ShopMill programs that are not in the folder in which you create the multiple clamping program, are displayed with the complete path



7. Place the cursor on the desired program and press the "Delete selection" softkey if you want to remove individual programs from the assignment list.

- OR -



Press the "Delete all" softkey if you want to remove all programs from the global program.



8. Press the "OK" softkey when the assignment list is complete.

This optimizes the tool changes.

The global program is then renumbered. The number of the current clamping is specified every time the program switches from one clamping to another.

Apart from the global program (XYZ.MPF), the file XYZ_MCD.INI is also set up in which the assignment between zero offsets and programs is stored. Both programs are stored in the directory that was previously selected in the Program Manager.

Note

If you switch from the assignment list (without canceling) to another function and then call the "Multiple clamping" function later, the same assignment list is displayed again.

Alarm, error, and system messages

13.1 Displaying alarms

If faulty conditions are recognized in the operation of the machine, then an alarm will be generated and, if necessary, the machining will be interrupted.

The error text that is displayed together with the alarm number gives you more detailed information on the error cause.

 CAUTION
<p>Dangers for persons and machines</p> <p>Please check the situation in the plant on the basis of the description of the active alarm(s). Eliminate the cause/s of the alarm/s and acknowledge it/them as instructed.</p> <p>Failure to observe this warning will place your machine, workpiece, stored settings and possibly even your own safety at risk.</p>

Alarm overview

You can display all upcoming alarms and acknowledge them.

The alarm overview contains the following information:

- Date and time
- Cancel criterion
 - specifies the key or softkey used to acknowledge the alarm
- Alarm number
- Alarm text

Procedure



1. Select the "Diagnostics" operating area.



2. Press the "Alarm list" softkey.
The "Alarms" window appears.
All pending alarms are displayed.

13.1 Displaying alarms



The "Hide SI alarms" softkey is displayed if safety alarms are pending.
 3. Press the "Hide SI alarms" softkey if you do not wish to display SI alarms.



4. Position the cursor on an alarm.

...



5. Press the key that is specified as acknowledgement symbol to delete the alarm.

- OR -



Press the "Delete HMI alarm" softkey to cancel an HMI alarm.

- OR -



Press the "Acknowledge alarm" softkey to delete a PLC alarm of the SQ type (alarm number as of 800000).

The softkeys are activated when the cursor is on the corresponding alarm.

Acknowledgement symbols

Symbol	Meaning
	Turn the unit off and back on (main switch), or press NCK POWER ON.
	Press the <RESET> key.
	Press the <ALARM CANCEL> key.
...	- OR -
	Press the "Acknowl. HMI alarm" softkey.
	Press the key provided by the manufacturer.



Machine manufacturer

Please refer to the machine manufacturer's specifications.

13.2 Displaying an alarm log

A list of all the alarms and messages that have occurred so far are listed in the "Alarm Log" window.

Up to 500 administered, incoming and outgoing events are displayed in chronological order.



Machine manufacturer

Please refer to the machine manufacturer's specifications.

Procedure



1. Select the "Diagnostics" operating area.



2. Press the "Alarm log" softkey.

The "Alarm Log" window opens.

All of the coming and going events - that have occurred since the HMI was started - are listed.



3. Press the "Display new" softkey to update the list of displayed alarms/messages.



4. Press the "Save Log" softkey.

The log that is currently displayed is stored as text file alarmlog.txt in the system data in directory card/user/sinumerik/hmi/log/alarm_log.

13.3 Displaying messages

PLC and part program messages may be issued during machining.

These messages will not interrupt the program execution. Messages provide information with regard to a certain behavior of the cycles and with regard to the progress of machining and are usually kept beyond a machining step or until the end of the cycle.

Overview of messages

You can display all issued messages.

The message overview contains the following information:

- Date
- Message number
is only displayed for PLC messages
- Message text

Procedure



1. Select the "Diagnostics" operating area.



2. Press the "Messages" softkey.
The "Messages" window appears.

13.4 Sorting, alarms, faults and messages

If a large number of alarms, messages or alarm logs are displayed, you have the option of sorting these in an ascending or descending order according to the following criteria:

- Date (alarm list, messages, alarm log)
- Number (alarm list, messages)

As a consequence, for every extensive lists, you can obtain the required information faster.

Procedure



1. Select the "Diagnostics" operating area.



2. Press the softkey "Alarm list", "Messages" or "Alarm log" to display the requested messages and alarms.

...



3. Press the "Sort" softkey.



The list of entries is sorted in ascending order according to date, i.e. the most recent information is at the end of the list.



4. Press the softkey "Descending" to sort the list in a descending order. The most recent event is shown at the beginning of the list.



5. Press the "Number" softkey if you wish to sort the alarm list or the list with messages according to numbers.



6. Press the "Ascending" softkey if you wish to display the list in an ascending order.

13.5 PLC and NC variables

13.5.1 Displaying and editing PLC and NC variables

The "NC/PLC Variables" window allows NC system variables and PLC variables to be monitored and changed.

You receive the following list in which you can enter the desired NC/PLC variables in order to display the actual values.

- Variable
Address for NC/PLC variable.

Incorrect variables have a red background and are displayed with a # character in the value column.
- Comment
Any comment on the variable.

The columns can be displayed and hidden.
- Format
Specify the format in which the variable is to be displayed.

The format can be specified (e.g. floating point).
- Value
Displays the actual value of the NC/PLC variables.

PLC variables	
Inputs	Input bit (Ex), input byte (EBx), input word (EWx), input double word (EDx)
Outputs	Output bit (Ax), output byte (ABx), output word (AWx), output double word (ADx)
Bit memory	Memory bit (Mx), memory byte (MBx), memory word (MWx), memory double word (MDx)
Times	Time (Tx)
Counters	Counter (Cx)
Data	Data block (DBx): Data bit (DBXx), data byte (DBBx), data word (DBWx), data double word (DBDx)

Formats	
B	Binary
H	Hexadecimal
D	Decimal without sign
+/-D	Decimal with sign
F	Floating point (for double words)
A	ASCII character

Notation for variables

- PLC variables
 - EB2
 - A1.2
 - DB2.DBW2
- NC variables
 - NC system variables - notation
 - \$AA_IM[1]
 - User variables/GUDs - notation
 - GUD/MyVariable[1,3]
 - OPI - notation
 - /CHANNEL/PARAMETER/R[u1,2]

Note

NC system variables and PLC variables

- System variables can be dependent on the channel. When the channel is switched over, the values from the corresponding channel are displayed.
 - For user variables (GUDs) it is not necessary to make a specification according to global or channel-specific GUDs. The indices of GUD arrays are, just like NC variables in the system variable syntax, 0-based; this means that the first element starts with the index 0.
 - Using the tooltip, for NC system variables, you can display the OPI notation (with the exception of GUDs).
-

Changing PLC variables

Changes can only be made to the PLC variables with the appropriate password.

 WARNING
Incorrect parameterization Changes in the states of NC/PLC variables have a major impact on the machine. Incorrect configuration of the parameters can endanger human life and cause damage to the machine.

Changing and deleting values



1. Select the "Diagnostics" operating area.



2. Press the "NC/PLC variables" softkey.

The "NC/PLC Variables" window opens.

3. Position the cursor in the "Variable" column and enter the required variable.



4. Press the <INPUT> key.

The operand is displayed with the value.



5. Press the "Details" softkey.

The "NC/PLC Variables: Details" window opens. The information for "Variable", "Comment" and "Value" is displayed in full length.



6. Position the cursor in the "Format" field and choose the required format with <SELECT>.



7. Press the "Display comments" softkey.

The "Comments" column is displayed. You have the option of creating comments or editing existing comments.



Press the "Display comments" softkey once again to hide the column.



8. Press the "Change" softkey if you would like to edit the value.

The "Value" column can be edited.



9. Press the "Insert variable" softkey if you wish to select a variable from a list of all existing variables and insert this.

The "Select Variable" window opens.



10. Press the "Filter/search" softkey to restrict the display of variables (e.g. to mode group variables) using the "Filter" selection box and/or select the desired variable using the "Search" input box.



Press the "Delete all" softkey if you would like to delete the entries for the operands.



11. Press the "OK" softkey to confirm the changes or the deletion.

- OR -



Press the "Cancel" softkey to cancel the changes.

Note

"Filter/Search" when inserting variables

The start value for "Filter/Search" of variables differs.

For example, to insert the variable \$R[0], set "Filter/Search":

- The start value is 0, if you filter according to "System variables".
 - The start value is 1, if you filter according to "All (no filter)". In this case, all signals are displayed and shown in the OPI notation.
-

Changing operands

Depending on the type of operand, you can increment or decrement the address by 1 place at a time using the "Operand +" and "Operand -" softkeys.

Note

Axis names as index

For axis names, the softkeys "Operand +" and "Operand -" do not act as index, e.g. for \$AA_IM[X1].



Examples

DB97.DBX2.5
Result: DB97.DBX2.6

\$AA_IM[1]
Result: \$AA_IM[2]



MB201
Result: MB200
/Channel/Parameter/R[u1,3]
Result: /Channel/Parameter/R[u1,2]

13.5.2 Saving and loading screen forms





You have the option of saving the configurations of the variables made in the "NC/PLC variables" window in a screen form that you reload again when required.

Editing screen forms

If you change a screen form that has been loaded, then this is marked using with * after the screen form name.

The name of a screen form is kept in the display after switching-off.

Procedure

1. You have entered values for the desired variables in the "NC/PLC variables" window.
2. Press the ">>" softkey.

3. Press the "Save screen" softkey.
The "Save screen: Select archiving" window opens.

4. Position the cursor on the template folder for variable screen forms in which your actual screen form should be saved and press the "OK" softkey.
The "Save screen: Name" window opens.

5. Enter the name for the file and press the "OK" softkey.
A message in the status line informs you that the screen form was saved in the specified folder.
If a file with the same name already exists, then you will receive a prompt.

6. Press the "Load screen" softkey.
The "Load screen" window opens and displays the sample folder for the variable screen forms.
7. Select the desired file and press the "OK" softkey.
You return to the variable view. The list of all of the predefined NC and PLC variables is displayed.

13.5.3 Load symbols

PLC data can also be edited via symbols.

To do this, the symbol tables and texts for the symbols in the PLC project must have been suitably prepared (STEP7) and made available in SINUMERIK Operate.

Preparing PLC data

Save the generated files in the `/oem/sinumerik/plc/symbols` directory.

Procedure



1. The variable view is opened.



2. Press the ">>" and "Load icons" softkeys.
The "Import PLC symbols: *.snh" window opens.



3. In the folder `/oem/sinumerik/plc/symbols`, select the `PlcSym.snh` file to import the symbols and then click on "OK".



4. In the folder `/oem/sinumerik/plc/symbols`, select the `PlcSym.snt` file to import the symbols and then press the "OK" softkey.

You will obtain an appropriate note if the tables were successfully imported.



5. Press the "OK" softkey.
You return to the "NC/PLC variables" window.

6. Restart the SINUMERIK Operate in order to activate the files.

13.6 Version

13.6.1 Displaying version data

The following components with the associated version data are specified in the "Version data" window:

- System software
- Basic PLC program
- PLC user program
- System extensions
- OEM applications
- Hardware

Information is provided in the "Nominal version" column as to whether the versions of the components deviate from the version supplied on the CompactFlash Card.



The version displayed in the "Actual version" column matches the version of the CF card.



The version displayed in the "Actual version" column does not match the version of the CF card.

You may save the version data. Version displays saved as text files can be further processed as required or sent to the hotline in the event of an error.

Procedure



1. Select the "Diagnosis" operating area.



2. Press the "Version" softkey.
The "Version Data" window appears.
Data from the available components are displayed.



3. Select the component for which you would like more information.



4. Press the "Details" softkey, in order to receive more exact information on the components displayed.

13.6.2 Save information

All the machine-specific information of the control is combined in a configuration via the user interface. You can save machine-specific information on the drives that have been set-up.

Procedure



1. Select the "Diagnostics" operating area.



2. Press the "Version" softkey.
It takes some time to call the version display. While the version data is being determined a progress message box and the appropriate text are displayed in the dialog line.



3. Press the "Save" softkey.
The "Save Version Information: Select Archive" window opens. The following storage locations are offered depending on the configuration:
 - Local drive
 - Network drives
 - USB
 - Version data (archive: Data tree in the "HMI data" directory)



4. Then press the "New directory" softkey if you wish to create your own directory.



5. Press the "OK" softkey. The directory is created.



6. Press the "OK" softkey again to confirm the storage location.

The "Save Version Information: Name" window opens. The following options are available:

- In the "Name:" text field, the file name is pre-assigned with <Machine name/no.>+<CF-card number>. "_config.xml" or "_version.txt" is automatically attached to the file names.
- In text field "Comment", you can add a comment that is stored with the configuration data.

Select the following data via a checkbox:

- Version data (.TXT): Output of pure version data in text format.
- Configuration data (.XML): Output of configuration data in XML format. The configuration file contains the data you entered under Machine identity, the license requirements, the version information and the logbook entries.



7. Press the "OK" softkey to start the data transfer.

13.7 Logbook

The logbook provides you with the machine history in an electronic form.

If service is carried out on the machine, this can be electronically saved. This means that it is possible to obtain a picture about the "History" of the control and to optimize service.

Editing the logbook

You can edit the following information:

- Editing information on the machine identity
 - Machine name/No.
 - Machine type
 - Address data
- Make logbook entries (e.g. "filter replaced")
- Deleting logbook entries

Note

Deleting logbook entries

Up to the 2nd commissioning, you have the option to delete all of the entered data up to the time of the first commissioning.

Output of the logbook

You have the possibility of exporting the logbook by generating a file using the "Save version" function in which the logbook is contained as section.

See also

Save information (Page 639)

13.7.1 Displaying and editing the logbook

Procedure



1. Select the "Diagnostics" operating area.



2. Press the "Version" softkey.



3. Press the "Logbook" softkey.
The "Machine logbook" window opens.

Editing end customer data



You have the option of changing the address data of the end customer using the "Change" softkey.

- OR -



Using the "Clean up" softkey, you can delete all logbook entries.



All entries, except the date of the first commissioning, are deleted and the softkey "Clean up" is deactivated.

Note

Deleting logbook entries

As soon as the 2nd commissioning has been completed, the "Clean up" softkey to delete the logbook data is no longer available.

13.7.2 Making a logbook entry

Using the "New logbook entry" window to make a new entry into the logbook.

Enter your name, company and department and a brief description of the measure taken or a description of the fault.

Note

If you wish to make line breaks in the "fault diagnostics/measure" field, use the key combination <ALT> + <INPUT>.

The date and entry number are automatically added.

Sorting the entries

The logbook entries are displayed numbered in the "machine logbook" window.

More recent entries are always added at the top in the display.

Procedure



1. The logbook is opened.
2. Press the "New entry" softkey.
The "New logbook entry" window opens.
3. Enter the required data and press the "OK" softkey.
You return to the "Machine logbook" window and the entry is displayed below the machine identity data.

Note

Deleting logbook entries

Up to the end of the 2nd commissioning, you have the option to delete the logbook entries up to the time of the first commissioning using the "Clean up" softkey.

Searching for a logbook entry

You have the option for searching for specific entries using the search function.



1. The "Machine logbook" window is opened.
2. Press the "Search..." softkey and enter the desired term in the search form. You can make a search according to date/time, company name/department or according to fault diagnostics/measure.

The cursor is positioned on the first entry that corresponds to the search term.



3. Press the "Continue search" softkey if the entry found is not the one that you are looking for.

Additional search option



Press the "Go to Beginning" softkey to start the search at the latest entry.

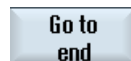

Press the "Go to End" softkey to start the search at the oldest entry.

13.8 Creating screenshots

You can create screenshots of the current user interface.

Each screenshot is saved as a file and stored in the following folder:

`/user/sinumerik/hmi/log/screenshot`

Procedure

Ctrl + P Press the <Ctrl+P> key combination.

A screenshot of the current user interface is created in .png format.

The file names assigned by the system run in ascending order from "SCR_SAVE_0001.png" to "SCR_SAVE_9999". You can create up to 9,999 screenshots.

Copy file



1. Select the "Start-up" operating area.



2. Press the "System data" softkey and open the specified folder.

As you cannot open screenshots in SINUMERIK Operate, you must copy the files to a Windows PC either via "WinSCP" or via a USB-FlashDrive.

You can open the files using a graphics program, e.g. "Office Picture Manager".

13.9 Remote diagnostics

13.9.1 Setting remote access

You can influence the remote access to your control in the "Remote diagnostics (RCS)" window.

Here, rights for all types of remote control are set. The selected rights are defined from the PLC and using the setting at the HMI.

The HMI can restrict the rights specified from the PLC, but however, cannot extend the rights beyond the PLC rights.

If the settings made permit access from outside, then this is still dependent on a manual or automatic confirmation.

Rights for remote access

The "Specified from PLC" field shows the access rights for remote access or remote monitoring specified from the PLC.



Machine manufacturer

Please refer to the machine manufacturer's specifications.

In the "Selected in the HMI" selection box, you have the possibility of setting rights for remote control:

- Do not permit remote access
- Permit remote monitoring
- Permit remote control

The combination of the settings in the HMI and in the PLC show the valid status as to whether access is permitted or not. This is displayed in the "Resulting from" line.

Settings for the confirmation dialog box

If the settings made for "Specified from the PLC" and "Selected in the HMI" permit access from outside, then this is however, still dependent on either a manual or automatic confirmation.

As soon as a remote access is permitted, at all of the active operating stations, a query dialog box is displayed for the operator at the active operating station to either confirm or reject an access.

For the case that there is no local operation, then the control behavior can be set for this particular scenario. You define how long this window is displayed and whether, after the confirmation has expired, the remote access is automatically rejected or accepted.

Display of the state



Remote monitoring active



Remote control active

If remote access is active, using these icons you will be informed in the status line as to whether a remote access is presently active or whether only monitoring is permitted.

Procedure



1. Select the "Diagnostics" operating area.



2. Press the "Remote diag." softkey.
The "Remote diagnostics (RCS)" window is opened.



3. Press the "Change" softkey.
The "Selected in the HMI" is activated.



4. If you desire remote control, select the entry "Permit remote control".

In order that remote control is possible, the entry "Permit remote control" must be specified in the fields "Specified from the PLC" and "Selected in the HMI".

5. Enter new values in the group "Behavior for confirming remote access" if you wish to change the behavior for confirming remote access.
6. Press the "OK" softkey.
The settings are accepted and saved.



References

For a description of configuration options, refer to the Commissioning Manual SINUMERIK Operate (IM9) / SINUMERIK 840D sl

13.9.2 Permit modem

You can permit remote access to your control via a teleservice adapter IE connected at X127.



Machine manufacturer

Please refer to the machine manufacturer's specifications.



Software option

You need the "MC Information System RCS Host" option to display the "Permit modem" softkey.

Procedure



1. The "Remote diagnostics (RCS)" window is opened.



2. Press the "Permit modem" softkey.
Access to the control via modem is enabled so that a connection can be established.



3. To block access again, press the "Permit modem" softkey again.

13.9.3 Request remote diagnostics

Using the "Request remote diagnostics" softkey, from your control you have the option of actively requesting remote diagnostics with your machinery construction OEM.

The access via modem must be enabled if the access is to be made via modem.



Machine manufacturer

Please refer to the machine manufacturer's specifications.

When requesting remote diagnostics, you obtain a window with the corresponding pre-assigned data and values of the ping service. If required, you can ask your machine manufacturer for this data.

Data	Meaning
IP address	IP address of the remote PC
Port	Standard port that is intended for remote diagnostics
Send duration	Duration of the request in minutes
Send interval	Cycle in which the message is sent to the remote PC in seconds
Ping send data	Message for the remote PC

Procedure



1. The "Remote diagnostics (RCS)" window is opened.



2. Press the "Request remote diagnostics" softkey.
The "Request remote diagnostics" window is displayed.



3. Press the "Change" softkey if you would like to edit the values.



4. Press the "OK" softkey.
The request is sent to the remote PC.

References

Commissioning Manual SINUMERIK Operate (IM9) / SINUMERIK 840D sl

13.9.4 Exit remote diagnostics

Procedure



1. The "Remote diagnostics (RCS)" is opened and it is possible that remote monitoring or remote access is active.
2. Block the modem access if access via modem is to be blocked.
- OR -
In the "Remote Diagnostics (RCS)" window, reset the access rights to "Permit no remote access".

Working with Manual Machine

"Manual Machine" offers a modified comprehensive spectrum of functions for manual mode. You can carry out all the important machining processes without writing a program.



Software options

You require the "ShopTurn/ShopMill" option for working with "Manual Machine".



Machine manufacturer

Please refer to the machine manufacturer's specifications.

Main screen

After the controller has powered up, the following basic screen is displayed:

The screenshot shows the Siemens manual machine control interface. At the top, there is a status bar with the Siemens logo, a date/time display (12/08/11 10:22 AM), and a 'JOG' button. Below this, the screen is divided into several sections:

- Top Section:** 'CHAN1 Reset' and 'SIEMENS' logo.
- Workpiece Position [mm]:**

Workpiece	Position [mm]
∅ X	0.000
Y	0.000
Z	0.000
B1	90.000 °
Z3	0.000
- Tool Parameters (T, F, S):**

Parameter	Value	Unit	Limit
T	0.000	mm/rev	15%
F	0.000	mm/rev	15%
S4	0	rpm	80%
- Tool Selection:** 'FRAESER_Grav D 1' is selected.
- Other M function:** 0.000 °
- Navigation:** A central joystick with directional arrows (+Z, -Z, +Y, -Y, +X, -X) and a green center button.
- Buttons:** 'Select tool', 'Angle milling', 'Stops', and 'Simulation'.
- Bottom Bar:** Icons for 'Meas. tool', 'Meas. workp.', 'Strght Circle', 'Drilling', 'Milling', and 'Simulation'.

Machining options

You have the following options for machining the workpieces:

- Manual mode
- Single-cycle machining

14.1 Measuring the tool

All the options of the manual and automatic measurement are available to determine the tool offset data (see also Section "Measuring the tool (Page 71)").

Procedure



1. "Manual Machine" is active.
2. Press the "Meas. tool" softkey.
3. Select the the required measuring function in the vertical softkey bar and press the appropriate softkey.

14.2 Measuring the workpiece zero

You can use the following workpiece elements to determine the workpiece zero:

- Edge
- Corner
- Pocket/hole
- Spigot
- Plane

You can measure the workpiece zero either manually or automatically (see Section "Measuring the workpiece zero (Page 78)").

Procedure



1. "Manual Machine" is active.
2. Press the "Workpiece zero" softkey.
3. Select the the required measuring variant in the vertical softkey bar and press the appropriate softkey.

14.3 Setting the zero offset

Select the work offset in the "Parameter" operating area directly in the work offset list.



Machine manufacturer

Please refer to the machine manufacturer's specifications.

Procedure

1. "Manual Machine" is active.
2. Select the "Parameter" operating area.
2. Press the "Work offset" and "G54...599" softkeys.



The "Work Offset G54...599" window opens.



3. Position the cursor on the desired work offset and press the softkey "WO selection"



Now return to the basic screen and enter the selected work offset in the "Work offset" field.

14.4 Set limit stop

You can limit the traversing range of the axes.

To do this, enter the values for the respective axes. The values refer to the workpiece coordinate system. The limits can be switched on and off individually.

Activated, i.e. active set limits, are indicated by a bar next to the wind rose in the direction graphic.

When a limit is reached, an alarm appears which disappears again when the axis is moved away from the limit.

Note

Mode change

Entered and activated limit stops remain active after switching from JOG mode to the MDA or AUTO mode.

Procedure



1. "Manual Machine" is active
2. Press the "Limit stops" softkey.
The "Limit Stops" window appears.



3. Enter the desired position of the limit stop for each axis.
- OR -
Press the "Set limit stop" softkey to enter the current position of an axis.



4. In the field next to the position specification select the entry "On" to activate the desired limit stop.
The bar is displayed next to the wind rose.



5. Press the "Back" softkey to return to the basic screen.
The active limit stops are also displayed here with bars.

14.5 Simple workpiece machining

In "Manual Machine", you machine workpieces directly in the "JOG" mode without creating a program.

Functions

The following functions are available to you for machining in manual mode:

- Axis movements
- Angular milling
- Straight (face and longitudinal milling) and circle





Note

Tool, spindle speed and direction of spindle rotation are activated with <CYCLE START>. A change in feedrate immediately becomes active.

14.5.1 Traversing axes

For preparatory actions and simple traversing movements, input the parameters directly into the "Manual Machine" input fields of the basic screen.

Tool selection

1. "Manual Machine" is active.
2. Select the desired tool in "T".

3. Enter the feedrate (F) and the spindle speed (S).
4. Select the direction of spindle rotation (e.g. clockwise direction of rotation):

- OR -
Set the direction of rotation via the machine control panel.
5. Press the <CYCLE START> key.

The spindle starts immediately after the tool is selected.

Note:

Please refer to the machine manufacturer's specifications.

Machining



6. Select the axis to be traversed on the machine control panel.

...



7. Press the <+> or <-> key on the machine control panel.

...

- OR -

Select the direction with the aid of the cross-switching lever.
The axes are moved at the set machining feedrate.

Note:

Please refer to the machine manufacturer's specifications.

The active direction is graphically displayed in the basic screen by means of the wind rose.

14.5.2 Angular milling

The basic effective direction can be selected via the axis direction keys or via the cross-switching lever. In addition, an angle (α_1) can also be entered.

Procedure



1. "Manual Machine" is active.
2. Press the "Angular milling" softkey.



3. Select the tool, spindle, and spindle direction and specify the machining feedrate.
4. Enter the desired angle α_1 .

Note

Selecting/deselecting the angular milling and changing the angle α_1 is only possible in the reset state.

Parameter	Description	Unit
T	Tool name	
D	Cutting edge number	
F	Feedrate	mm/min mm/rev
S / V	Spindle speed or constant cutting rate	rev/min m/min
$\alpha 1$	Rotation of the coordinate system	Degrees
Other M function	Input of machine functions Refer to the machine manufacturer's table for the correlation between the meaning and number of the function.	
Zero offset	Selecting the zero offset.	

14.5.3 Straight and circular machining

14.5.3.1 Straight milling

Use this function for simple, straight machining (e.g. face or longitudinal turning).

Procedure

1. "Manual Machine" is active.
2. Press the "Straight Circle" softkey.



3. Select the desired straight machining and press the "Straight all axes" softkey



- OR -



- OR -

4. Specify the desired value for the feedrate F.

- OR -



Press the "Rapid traverse" softkey.
The rapid traverse is displayed in field "F".

5. Enter the target position and, if required, the angle (α) for the axis or axes to be traversed.



Using the "Graphic view" softkey, you can toggle between the help screen and the graphic view in the screen.

Parameter	Description	Unit
F 	Feedrate	mm/min mm/rev
	Straight all axes	
X	Target position in the X direction (abs or inc)	mm
Z	Target position in the Z direction (abs or inc)	mm
Y	Target position in the Y direction (abs or inc)	mm
B	Target position of the B axis (abs or inc)	mm
	Straight X α	
X	Target position in the X direction (abs or inc)	mm
α	Angle of the straight line to the X axis	Degrees
	Straight Z α	
Z	Target position in the Z direction (abs or inc)	mm
α	Angle of the straight line to the Z axis	Degrees

14.5.3.2 Circular milling

You can use this function for a simple circular machining.





Procedure



1. "Manual Machine" is active.
2. Press the "Straight circle" softkey.
3. Press the "Circle" softkey.
4. Specify the desired value for the feedrate F.
5. Select the desired circle input (e.g. "End point + radius") and the direction of rotation.
6. Enter the target position as well as the circle center point or radius.

Using the "Graphic view" softkey, you can toggle between the help screen and the graphic view in the screen.

Parameter

Parameter	Description	Unit
F 	Feedrate	mm/min mm/rev
Circle input	<ul style="list-style-type: none"> • End point + center point • End point + radius 	mm
Direction of rotation 		
Z 	Target position in the Z direction (abs and inc)	mm
X 	Target position in the X direction (abs and inc)	mm
K	Center of the circle K (inc) - only if circle input via end point and center point Note: Incremental dimensions: The sign is also evaluated.	mm

Parameter	Description	Unit
I	Center of circle I (inc) - only if circle input via end point and center point	mm
PL 	Circle plane <ul style="list-style-type: none"> • XY IJ • YZ JK • ZX KI 	

14.6 More complex machining

The following functions are available to you for more extensive and complicated machining in manual mode:

- Drilling (axial drilling, axial threads, drilling, reaming, deep-drilling, threads)
- Milling (pocket, shank, groove, multi-edged, engraving)
- Contour milling (contour, path milling, predrilling, pocket, spigots)

General sequence

For more complex machining processes, proceed in the following order:

- Select the desired function via the corresponding softkey.
- Input the desired values in the parameter screen form.
- Press the "OK" softkey in order to accept the values.

The input screen form closes.

A line with the specified parameters is displayed on the basic screen.

- Press the <CYCLE START> key.

The selected cycle is started.

Note

Note

You can return to the parameter screen form at any time to check and correct the inputs.

Press the "Cursor right" key to jump back to the input screen form.

Drilling a position pattern

You can drill a position pattern:

- First select the desired function (e.g. "Centering") via the softkey in "Drilling".
- Select the appropriate tool, enter the desired values in the parameter screen and press the "Accept" softkey to confirm the technology block.

The input screen is closed and the line with the technology data is displayed in the main screen.

- Press the "Positions" softkey and select the desired position pattern (e.g. any positions) via softkey, enter the desired values in the parameter screen form press the "Accept" softkey.

The input screen is closed and the technology and positioning blocks are displayed in brackets.

Swiveling

Manual swivel is available for the setup, measuring and machining of workpieces with inclined, swiveled surfaces (see Section "Swiveling (Page 137)").

Approach and retraction

When machining the workpiece, you traverse from the current position to the machining start point. After the machining process, the tool is returned along a direct path to the starting point.

14.6.1 Drilling with Manual Machine

The same range of technological functions (cycles) is available as in automatic mode for drilling on the face or peripheral surface of a workpiece:



Parameter

The parameters of the input screen forms correspond to the parameters under Automatic (see Section "Drilling (Page 299)").

14.6.2 Milling with Manual Machine

The same range of technological functions (cycles) is available as in automatic mode for the milling of simple geometric shapes:

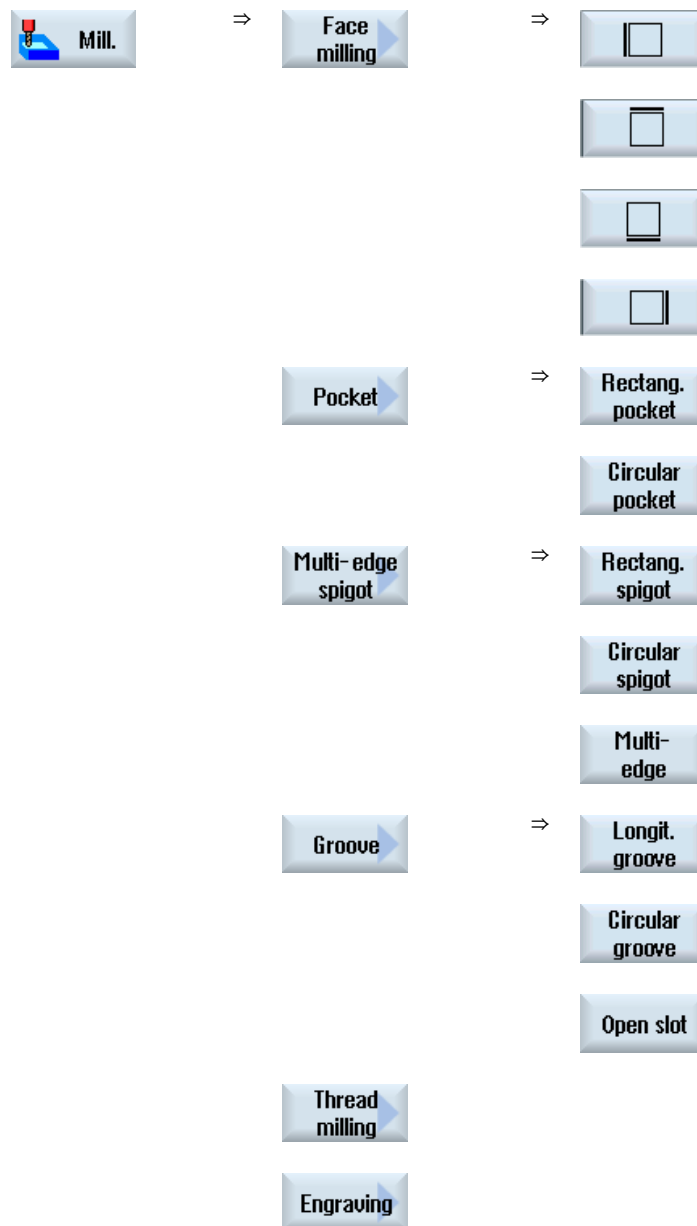

Parameter

The parameters of the input screen forms correspond to the parameters under Automatic (see Section "Milling (Page 334)").

14.6.3 Contour milling with manual machine

The same range of technological functions (cycles) is available as in automatic mode for contour milling of simple geometric shapes:

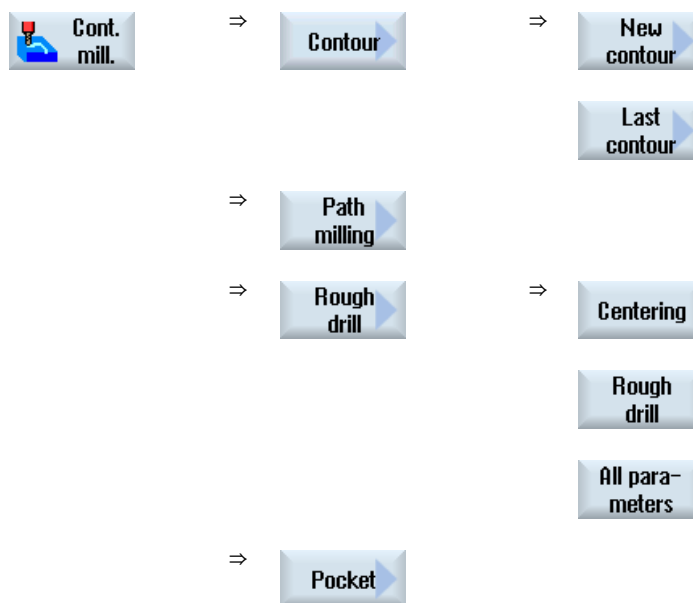

Parameter

The parameters of the input screen forms correspond to the parameters under Automatic (see Section Auto-Hotspot

14.7 Simulation and simultaneous recording

For more complex machining processes, you can check the result of your inputs with the aid of the simulation, without having to traverse the axes (see Section "Simulating machining (Page 209)"). The execution of the work steps is graphically displayed on the screen during this.



Software option

You require the option "Simultaneous recording (real-time simulation)" for the simultaneous recording of the work steps.

Note

In "Manual Machine", you can simulate a work step with an already opened and filled out parameter screen form.

Teaching in a program

15.1 Overview

The "Teach in" function can be used to edit programs in the "AUTO" and "MDA" modes. You can create and modify simple traversing blocks.

You traverse the axes manually to specific positions in order to implement simple machining sequences and make them reproducible. The positions you approach are applied.

In "AUTO" teach-in mode, the selected program is "taught".

In "MDA" teach-in mode, you teach to the MDA buffer.

External programs, which may have been rendered offline, can therefore be adjusted and modified according to need.

15.2 General sequence

General sequence

Select the desired program block, press the relevant softkey "Teach position", "Rap. tra. G01", "Straight line G1" or "Circ. interm. pos. CIP", and "Circ. end pos. CIP" and traverse the axes to change the program block.

You can only overwrite a block with a block of the same type.

- OR -

Position the cursor at the desired point in the program, press the relevant softkey "Teach position", "Rap. tra. G01", "Straight line G1" or "Circ. interp. pos. CIP", and "Circ. end pos. CIP" and traverse the axes to insert a new program block.

In order for the block to be inserted, the cursor must be positioned in an empty line using the cursor key and input key.

Press the "Accept" softkey to teach-in the modified or new program block.

Note

All defined axes are "taught in" in the first teach-in block. In all additional teach-in blocks, only axes modified by axis traversing or manual input are "taught in".

If you exit teach-in mode, this sequence begins again.

Operating mode or operating area switchover

If you switch to another operating mode or operating area in teach-in mode, the position changes will be canceled and teach-in mode will be cleared.

15.3 Inserting a block

You have the option of traversing the axes and writing the current actual values directly to a new position block.

Requirement

"AUTO" mode: The program to be edited is selected.

Proceed as follows



1. Select the "Machine" operating area.



2. Press the <AUTO> or <MDA> key.



3. Press the <TEACH IN> key.



4. Press the "Teach prog." softkey.



5. Traverse the axes to the relevant position.
6. Press the "Teach position" softkey.
A new program block with the current actual position values will be created.

15.3.1 Input parameters for teach-in blocks

Parameters for teach-in of position and teach-in of G0, G1, and circle end position CIP

Parameter	Description
X	Approach position in X direction
Y	Approach position in Y direction
Z	Approach position in Z direction
F	Feedrate (mm/r; mm/min) - only for teach-in of G1 and circle end position CIP
	

Parameters for teach-in of circle intermediate position CIP

Parameter	Description
I	Coordinate of the circle center point in the X direction
J	Coordinate of the circle center point in the Y direction
K	Coordinate of the circle center point in the Z direction

Transition types for teach-in of position and teach-in of G0 and G1, and ASPLINE

The following parameters are offered for the transition:

Parameter	Description
G60	Exact stop
G64	Corner rounding
G641	Programmable corner rounding
G642	Axis-specific corner rounding
G643	Block-internal corner rounding
G644	Axis dynamics corner rounding

Motion types for teach-in of position and teach-in of G0 and G1

The following motion parameters are offered:

Parameter	Description
CP	Path-synchronous
PTP	Point-to-point
PTPG0	Only G0 point-to-point

Transition behavior at the beginning and end of the spline curve

The following motion parameters are offered:

Parameter	Description
Start	
BAUTO	Automatic calculation
BNAT	Curvature is zero or natural
BTAN	Tangential
End	
EAUTO	Automatic calculation
ENAT	Curvature is zero or natural
ETAN	Tangential

15.4 Teach-in via window

15.4.1 General

The cursor must be positioned on an empty line.

The windows for pasting program blocks contain input and output fields for the actual values in the WCS. Depending on the default setting, selection fields with parameters for motion behavior and motion transition are available.

When first selected, the input fields are empty unless axes were already traversed before the window was selected.

All data from the input/output fields are transferred to the program via the "Accept" softkey.

Precondition

"AUTO" mode: The program to be edited is selected.

Procedure



1. Select the "Machine" operating area.



2. Press the <AUTO> or <MDA> key.



3. Press the <TEACH IN> key.



4. Press the "Teach prog." softkey.

5. Use the cursor and input keys to position the cursor at the desired point in the program.

If an empty row is not available, insert one.



6. Press the softkeys "Rap. tra. G0", "Straight line G1", or Circ. interm. pos. CIP" and "Circ. end pos. CIP".

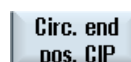

The relevant windows with the input fields are displayed.

7. Traverse the axes to the relevant position.



8. Press the "Accept" softkey.
A new program block will be inserted at the cursor position.

- OR -



Press the "Cancel" softkey to cancel your input.

15.4.2 Teach in rapid traverse G0

You traverse the axes and teach-in a rapid traverse block with the approached positions.

Note

Selection of axes and parameters for teach-in

You can select the axes to be included in the teach-in block in the "Settings" window.

You also specify here whether motion and transition parameters are offered for teach-in.

15.4.3 Teach in straight G1

You traverse the axes and teach-in a machining block (G1) with the approached positions.

Note

Selection of axes and parameters for teach-in

You can select the axes to be included in the teach-in block in the "Settings" window.

You also specify here whether motion and transition parameters are offered for teach-in.

15.4.4 Teaching in circle intermediate and circle end point CIP

Enter the intermediate and end positions for the circle interpolation CIP. You teach-in each of these separately in a separate block. The order in which you program these two points is not specified.

Note

Make sure that the cursor position does not change during teach-in of the two positions.

You teach-in the intermediate position in the "Circle intermediate position CIP" window.

You teach-in the end position in the "Circle end position CIP" window.

The intermediate or interpolation point is only taught-in with geometry axes. For this reason, at least 2 geometry axes must be set up for the transfer.

Note

Selection of axes for teach in

You can select the axes to be included in the teach-in block in the "Settings" window.

15.4.5 Teach-in A spline

For Akima-spline interpolation, you enter interpolation points that are connected by a smooth curve.

Enter a starting point and specify a transition at the beginning and end.

You teach-in each interpolation point via "Teach in of position".



Software option

You require the "Spline-Interpolation" option for A Spline interpolation.

Note

The relevant option bit must be set to enable you to program a spline interpolation.



Machine manufacturer

Please refer to the machine manufacturer's specifications.

Procedure



1. Select the "Machine" operating area.



2. Press the <AUTO> or <MDA> key.



3. Press the <TEACH IN> key.



4. Press the "Teach prog." softkey.



5. Press the ">>" and "ASPLINE" softkeys.
The "Akima-spline" window opens with the input fields.



6. Traverse the axes to the required position and if necessary, set the transition type for the starting point and end point.



7. Press the "Accept" softkey.
A new program block will be inserted at the cursor position.

- OR -



Press the "Cancel" softkey to cancel your input.

Note

Selection of axes and parameters for teach-in

You can select the axes to be included in the teach-in block in the "Settings" window.

You also specify here whether motion and transition parameters are offered for teach-in.

15.5 Editing a block

You can only overwrite a program block with a teach-in block of the same type.

The axis values displayed in the relevant window are actual values, not the values to be overwritten in the block.

Note

If you wish to change any variable in a block in the program block window other than the position and its parameters, then we recommend alphanumerical input.

Requirement

The program to be processed is selected.

Procedure



1. Select the "Machine" operating area.



2. Press the <AUTO> or <MDA> key.



3. Press the <TEACH IN> key.



4. Press the "Teach prog." softkey.



5. Click the program block to be edited.

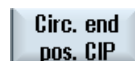

6. Press the relevant softkey "Teach position", "Rap. tra. G0", "Straight line G1", or "Circ. interm. pos. CIP", and "Circ. end pos. CIP".

The relevant windows with the input fields are displayed.



7. Traverse the axes to the desired position and press the "Accept" softkey.

The program block is taught with the modified values.

- OR -



Press the "Cancel" softkey to cancel the changes.

15.6 Selecting a block

You have the option of setting the interrupt pointer to the current cursor position. The next time the program is started, processing will resume from this point.

With teach-in, you can also change program areas that have already been executed. This automatically disables program processing.

You must press reset or select a block to resume the program.

Requirement

The program to be processed is selected.

Proceed as follows



1. Select the "Machine" operating area.



2. Press the <AUTO> key.



3. Press the <TEACH IN> key.



4. Press the "Teach prog." softkey.



5. Place the cursor on the desired program block.
6. Press the "Block selection" softkey.

15.7 Deleting a block

You have the option of deleting a program block entirely.

Requirement

"AUTO" mode: The program to be processed is selected.

Procedure



1. Select the "Machine" operating area.



2. Press the <AUTO> or <MDA> key.



3. Press the <TEACH IN> key.



4. Press the "Teach prog." softkey.



5. Click the program block to be deleted.



6. Press the ">>" and "Delete block" softkeys.

The program block on which the cursor is positioned is deleted.

In the "Settings" window, you define which axes are to be included in the teach-in block and whether motion-type and continuous-path mode parameters are to be provided.

Proceed as follows



1. Select the "Machine" operating area.



2. Press the <AUTO> or <MDA> key.



3. Press the <TEACH IN> key.



4. Press the "Teach prog." softkey.



5. Press the ">>" and "Settings" softkeys.
The "Settings" window appears.



6. Under "Axes to be taught" and "Parameters to be taught", select the check boxes for the relevant settings and press the "Accept" softkey to confirm the settings.

16.1 HT 8 overview

The mobile SINUMERIK HT 8 handheld terminal combines the functions of an operator panel and a machine control panel. It is therefore suitable for visualization, operation, teach in, and programming at the machine.



- 1 Customer keys (user-defined)
- 2 Traversing keys
- 3 User menu key
- 4 Handwheel (optional)

Operation

The 7.5 TFT color display provides touch operation.

It also has membrane keys for traversing the axes, for numeric input, for cursor control, and for machine control panel functions like start and stop.

It is equipped with an emergency stop button and two 3-position enabling buttons. You can also connect an external keyboard.

References

For more information about connection and startup of the HT 8, see the following references:
Commissioning Manual SINUMERIK Operate (IM9) / SINUMERIK 840D sl

Customer keys

The four customer keys are freely assignable and can be set up customer-specifically by the machine manufacturer.



Machine manufacturer

Please refer to the machine manufacturer's specifications.

Integrated machine control panel

The HT 8 has an integrated machine control panel consisting of keys (e.g. start, stop, traversing keys, etc.), and keys reproduced as softkeys (see machine control panel menu).

See Section "Controls on the machine control panel" for a description of the individual keys.

Note

PLC interface signals that are triggered via the softkeys of the machine control panel menus are edge triggered.

Enabling button

The HT 8 has two enabling buttons. Thus, you can initiate enabling functions for operations that require enabling (e.g. displaying and operating of traversing keys) with either your right hand or your left hand.

Enabling buttons are available for the following key positions:

- Released (no activation)
- Enabling (center position) - enabling for channel 1 and 2 is on the same switch
- Panic (completely pushed through)

Traversing keys

To traverse the axes of your machine using the traversing keys of the HT 8, you must select "JOG" mode or either the "Teach In" or "Ref.Point" submode. Depending on the setting, the enabling button must be activated.



Machine manufacturer

Please refer to the machine manufacturer's specifications.

Virtual keyboard

A virtual keyboard is available for the easy entry of values.

Changing the channel

- You are able to switch the channel by touch in the status display:
 - In the Machine operating area (large status display), by touch operation of the channel display in the status display.
 - In the other operating areas (no status display), by touch operation of the channel display in the screen headers (yellow field).
- The "1... n CHANNEL" softkey is available in the machine control panel menu that can be reached via the user menu key "U".

Operating area switchover

You can display the operating area menu by touching the display symbol for the active operating area.

Handwheel

The HT 8 is available with a hand wheel.

References

For information about connecting the hand wheel, refer to:

Operator Components and Networking Manual; SINUMERIK 840D sl/840Di sl

16.2 Traversing keys

The traversing keys are not labeled. However, you can display a label for the keys in place of the vertical softkey bar.

Labeling of the traversing keys is displayed for up to six axes on the touch panel by default.



Machine manufacturer

Please refer to the machine manufacturer's specifications.

Showing and hiding

You can link the showing and hiding of the label to activation of the enabling button, for example. In this case, the traversing keys are displayed when you press the enabling button.

If you release the enabling button, the traversing keys are hidden again.



Machine manufacturer

Please refer to the machine manufacturer's specifications.



All existing vertical and horizontal softkeys are covered or hidden, i.e. other softkeys cannot be used.

16.3 Machine control panel menu

Here you select keys from the machine control panel which are reproduced by the software by touch operation of the relevant softkeys.

See chapter "Controls on the machine control panel" for a description of the individual keys.

Note

PLC interface signals that are triggered via the softkeys of the machine control panel menus are edge triggered.

Showing and hiding

The user menu key "U" displays the CPF softkey bar (vertical softkey bar) and the user softkey bar (horizontal softkey bar).

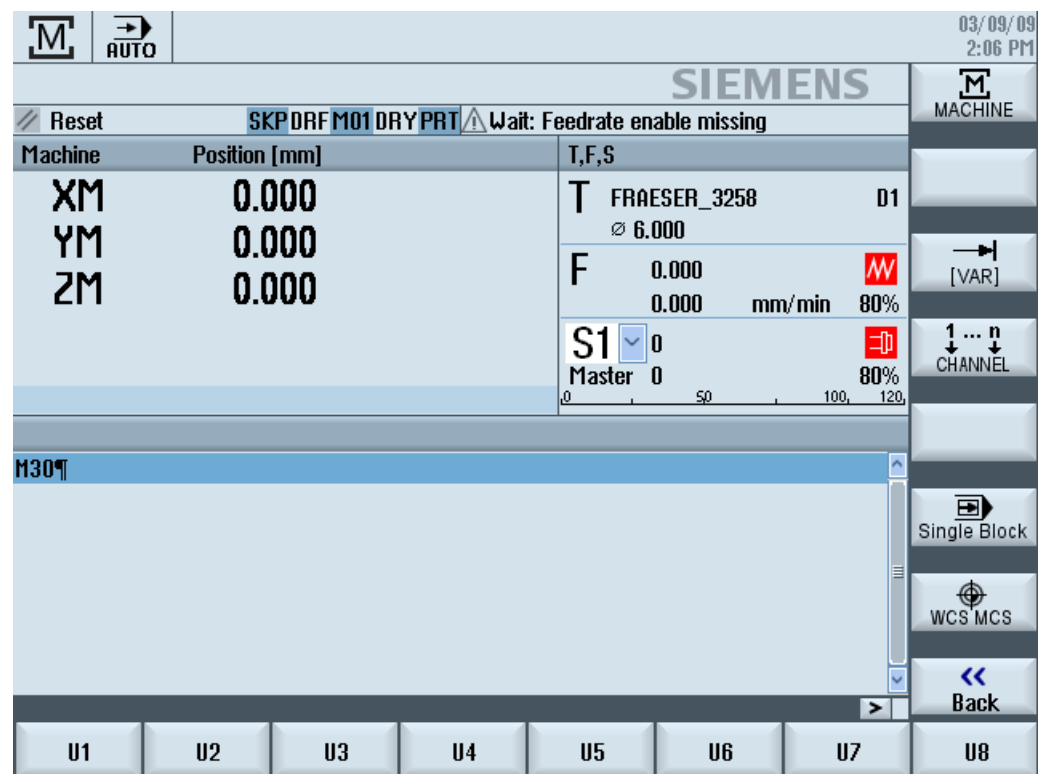

You can expand the user softkey bar to display eight additional softkeys via the menu forward key.



You use the "Back" softkey to hide the menu bar again.

Softkeys on the machine control panel menu

Available softkeys:

"Machine" softkey	Select the "Machine" operating area
"[VAR]" softkey	Select the axis feedrate in the variable increment
"1... n CHANNEL" softkey	Change the channel
"Single Block" softkey	Switch single block execution on/off
"WCS MCS" softkey	Switch between WCS and MCS
"Back" softkey	Close the window.

Note

The window will automatically disappear when changing regions areas with the "Menu Select" key.

16.4 Virtual keyboard

The virtual keyboard is used as the input device for touch operator panels.

It opens when you double-click an operator element with input capability (editor, edit field). The virtual keyboard can be positioned anywhere on the operator interface. In addition, you can toggle between a full keyboard and a reduced keyboard that only includes the number block. Moreover, with the full keyboard, you can toggle between English key assignments and the keyboard assignment for the current language setting.

Procedure

1. Click in the required input field in order to place the cursor there.
2. Click the input field.
The virtual keyboard is displayed.
3. Enter your values via the virtual keyboard.
4. Press the <INPUT> key.



- OR -

Position the cursor on an another operator element.

The value is accepted and the virtual keyboard is closed.

Positioning of the virtual keyboard

You can position the virtual keyboard anywhere in the window by pressing the empty bar next to the "Close window" icon with your finger or a stylus and moving it back and forth.

Special keys on the virtual keyboard

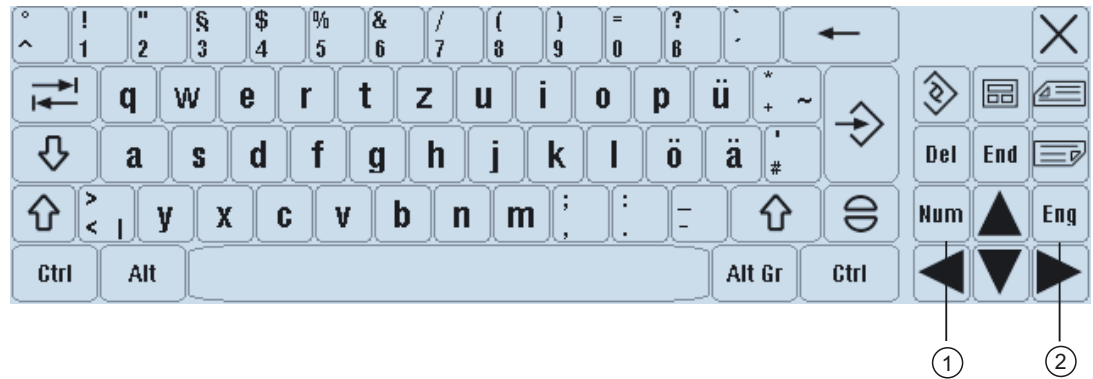

- 1 Num:
Reduces the virtual keyboard to the number block.
- 2 Eng:
Toggles the keyboard assignment between the English keyboard assignment and the keyboard assignment for the current language setting.

Number block of the virtual keyboard

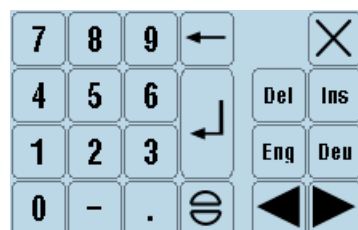

Use the "Deu" or "Eng" keys to return to the full keyboard with the English keyboard assignment or the keyboard assignment of the current language setting.

16.5 Calibrating the touch panel

It is necessary to calibrate the touch panel upon first connection to the controller.

Note

Recalibration

If the operation is not exact, then redo the calibration.



Procedure



1. Press the back key and the <MENU SELECT> key at the same time to start the TCU service screen.
2. Touch the "Calibrate TouchPanel" button.
The calibration process will be started.
3. Follow the instructions on the screen and touch the three calibration points one after the other.
The calibration process has terminated.
4. Touch the horizontal softkey "1" or the key with the number "1" to close the TCU service screen.

Ctrl-Energy

17.1 Overview

The "Ctrl-Energy" function provides you with the following options to improve the energy utilization of your machine.

Ctrl-E Analysis: Measuring and evaluating the energy consumption

Acquiring the actual energy consumption is the first step to achieving better energy efficiency. The energy consumption is measured and displayed at the controller using the SENTRON PAC multi-function device.

Depending on the configuration and connection of the SENTRON PAC, you have the possibility of either measuring the power of the whole machine or only a specific load.

Independent of this, the power is determined directly from the drives and displayed.

Ctrl-E Profiles: Control of energy saving states of the machine

To optimize the energy consumption, you have the option of defining energy saving profiles and saving them. For instance, your machine has a basic and a more sophisticated energy-saving mode - or under certain conditions, automatically switches itself off.

These defined energy states are saved as profiles. At the user interface, you have the possibility of activating these energy-saving profiles (e.g. the so-called tea break key).

Note

Ctrl-E Deactivating profiles

Disable Ctrl-E profiles before a series startup in order to prevent the NCU unintentionally shutting down.



Machine manufacturer

Please refer to the machine manufacturer's specifications.

17.2 Displaying energy consumption

You have the option of displaying the actual energy consumption values of the individual axes and the total energy consumption.

Display	Meaning
Manual	<ul style="list-style-type: none"> No input Entering and displaying a fixed value Displaying a value from a data source
Sentron PAC	Displaying an actual value measured by a SENTRON PAC device.
Total, drives	Display of the total of all measured drive values.
Total, machine	Addition of the values of all axes as well as a fixed value and Sentron PAC.

The display in the table depends on the configuration.

References

Information on the configuration is provided in the following reference:

System Manual "Ctrl-Energy", SINUMERIK 840D sl / 828D

Procedure



1. Select the "Parameter" operating area and press the "Ctrl-Energy" softkey.



- OR -



+

Press the <Ctrl> + <E> keys.



2. Press the "Energy analysis" softkey.
The "SINUMERIK Ctrl-Energy Analysis" window opens.
You obtain a display of the actual active power for all of the axes.

17.3 Measuring and saving the energy consumption

For the currently selected axes, you have the option of measuring and recording the energy consumption.

Measurement of the energy consumption by part programs

The energy consumption of part programs can be measured. The measurement should take single drives into account.

They specify in which channel the start and stop of the part program should be initiated and which number of repetitions are to be measured.

Save measurements

Save the measured consumption values so that you can subsequently compare the data.

Note

Up to three data records are displayed. The oldest data record is automatically overwritten if there are more than three measurements.

Measurement duration

The measurement duration is limited. When the maximum measurement duration is reached, the measurement is terminated and a corresponding message is output in the dialog line.



Machine manufacturer

Please refer to the machine manufacturer's specifications.

Procedure



1. The "Ctrl-Energy Analysis" window opens.
2. Press the "Start measurement" softkey.
The "Setting Measurement: Select Device" window opens.
3. Select the desired device in the list, possibly activate the "Measure part program" checkbox, enter the number of repetitions, possibly select the desired channel, and press the "OK" softkey.
The trace is started.
4. Press the "Stop measurement" softkey.
The measurement is ended.

17.4 Long-term measurement of the energy consumption



5. Press the "Graphic" softkey, to track the measurement characteristic.



6. If you want to track the consumption values, press the "Details" softkey.



7. Press the "Save measurement" softkey to save the consumption values of the actual measurement.

The selection of the axis to be measured depends on the configuration.

References

Information on the configuration is provided in the following reference:

System Manual "Ctrl-Energy", SINUMERIK 840D sl / 828D

17.4 Long-term measurement of the energy consumption

The long-term measurement of energy consumption is performed in the PLC and saved. The values from times in which the HMI is not active are also recorded.

Measured values

The infeed and regenerative power values as well as the sum of the power are displayed for the following periods:

- Current and previous day
- Current and previous month
- Current and previous year

Requirement

SETRON PAC is connected.

Procedure

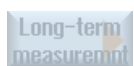

1. The "Ctrl-Energy Analysis" window opens.
2. Press the "Long-term measurement" softkey.
The "SINUMERIK Ctrl-Energy Analysis Long-term Measurement" window opens.
The results of the long-term measurement are displayed.



4. Press the "Back" softkey to terminate the long-term measurement.

17.5 Displaying measured curves

Display	Meaning
Start of the measurement	Shows the time at which the measurement was started by the pressing the "Start measurement" softkey.
Duration of the measurement [s]	Shows the measuring duration in seconds until the "Stop measurement" softkey is pressed.
Device	Displays the selected measured component. <ul style="list-style-type: none"> • Manual • Total, drives • Total, machine
Supplied energy [kWh]	Shows the supplied energy of the selected measured component in kilowatts per hour.
Regenerated energy [kWh]	Shows the regenerated energy of the selected measured component in kilowatts per hour.
Energy totals [kWh]	Shows the total of all measured drive values or the total of all axes as well as fixed value and Sentron PAC.

Procedure



1. The "SINUMERIK Ctrl-Energy Analysis" window opens and you have already performed and saved measurements.
2. Press the "Graphic" and "Saved measurements" softkeys.
The measurement curves are displayed in the "SINUMERIK Ctrl-Energy Analysis" window.
3. Press the "Saved measurements" softkey again if you only want to see the actual measurement.
4. Press the "Details" softkey for the exact measurement data and consumption values of the last three saved measurements and possibly a current measurement.

17.6 Using the energy-saving profile

In the "SINUMERIK Ctrl-Energy Energy-Saving Profile" window, you can display all of the defined energy-saving profiles. Here, directly activate the required energy-saving profile - or inhibit or release profiles.

SINUMERIK Ctrl-Energy energy-saving profiles

Display	Meaning
Energy-saving profile	All energy-saving profiles are listed.
active in [min]	The remaining time up until the defined profile is reached is displayed.

Note

Disable all energy-saving profiles

For example, in order not to disturb the machine while measurements are being made, select "Disable all".

Once the pre-warning time of a profile has been reached, an alarm window that shows the remaining time is displayed. Once the energy-saving mode has been reached, then an appropriate message is displayed in the alarm line.

Energy-saving profiles

Energy-saving profile	Meaning
Simple energy-saving mode (machine standby)	Machine units that are not required are either throttled or shut down. When required, the machine is immediately ready to operate again.
Full energy-saving mode (NC standby)	Machine units that are not required are either throttled or shut down. Wait times are incurred at the transition into the ready to operate state.
Maximum energy-saving mode (auto shut-off)	The machine is completely switched-off. Longer wait times are incurred at the transition into the ready to operate state.



Machine manufacturer

The selection and function of the displayed energy-saving profiles can differ. Please refer to the machine manufacturer's specifications.

References

Information on the configuration of the energy-saving profiles is provided in the following reference:

System Manual "Ctrl-Energy", SINUMERIK 840D sl / 828D

Procedure



1. Select the "Parameter" operating area.



2. Press the menu forward key and then the "Ctrl-Energy" softkey.



- OR -

Press the <CTRL> + <E> keys.



+



The "SINUMERIK Ctrl-Energy Energy-Saving Profiles" window opens.



3. Position the cursor on the required energy-saving profile and press the "Activate immediately" softkey if you wish to directly activate this state.



4. Position the cursor on the required energy-saving profile and press the "Disable profile" softkey if you wish to disable this state.

The profile is disabled. The energy-saving profile cannot be active, i.e. it is grayed out and displayed without time details.

The labeling of the "Disable profile" softkey changes to "Enable profile".



Press the "Enable profile" softkey in order to withdraw the energy-saving profile disable.



5. Press the "Disable all" softkey in order to disable all states.

All the profiles are disabled and can be non-active.

The labeling of the "Disable all" softkey changes to "Enable all".



6. Press the "Enable all" softkey to withdraw the disable for all profiles.

Easy Message (828D only)

18.1 Overview

Easy Message enables you to be informed about certain machine states by means of SMS messages via a connected modem:

- For example, you would like to be informed about emergency stop states
- You would like to know when a batch has been completed

Control commands

- HMI commands are used to activate or deactivate a user.

Syntax: [User ID] deactivate, [User ID] activate

- A special area is reserved in the PLC to which you can send commands in the form of PLC bytes using SMS commands.

Syntax: [User ID] PLC DataByte

The user ID is optional and required only if a corresponding ID has been specified in the user profile. The string PLC indicates that a PLC byte is to be written. It is followed by the data byte to be written in the following format: Base#Value. Base can take the values 2, 10 and 16 and defines the number base. Then follows the separator # and the value of the byte. Only positive values are allowed to be sent.

Examples:

2#11101101

10#34

16#AF



Machine manufacturer

Please refer to the machine manufacturer's specifications.

Active users

In order to receive an SMS message for certain events, you must be activated as user.

User logon

As registered user, you can log on via SMS to inquire about messages.

Action log

You can obtain precise information about incoming and outgoing messages via SMS logs.

References

Information on the GSM modem can be found in the PPU SINUMERIK 828D Manual

Calling the SMS Messenger



1. Select the "Diagnostics" operating area.



2. Press the "Easy Msg." softkey.

18.2 Activating Easy Message

To commission the connection to the modem for the SMS Messenger, activate the SIM card at the initial start-up.

Requirement

The modem is connected and activated.



Machine manufacturer

The modem is activated via the machine data 51233 \$MSN_ENABLE_GSM_MODEM.

Please refer to the machine manufacturer's specifications.

Procedure

Activating the SIM card



1. Press the "Easy Msg." softkey.
The "SMS Messenger" window appears.
"Status" shows that the SIM card has not been activated with a PIN.

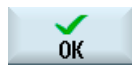

2. Enter the PIN, repeat the PIN and press the "OK" softkey.



3. If you made an incorrect entry several times, enter the PUK code in the "PUK Input" window and press the "OK" softkey to activate the PUK code.

The "PIN input" window is opened and you can enter the PIN number as usual.

Activating a new SIM card



1. Press the "Easy Msg." softkey.

The "SMS Messenger" window appears.

"Status" shows that the connection to the modem has been activated.



2. Press the "Settings" softkey.



3. Press the "Delete PIN" softkey to delete the stored PIN.

Enter the new PIN in the "PIN Input" window at the next power up.

18.3 Creating/editing a user profile

User identification

Display	Meaning
User name	Name of the user to be created or logged on.
Telephone number	Telephone number of the user to which the messages are to be sent. The telephone number must include the country code in order that control commands can identify the sender (e.g. +49172999999)
User ID	<p>The user ID has 5 digits (e.g. 12345)</p> <ul style="list-style-type: none"> • It is used to activate and deactivate the user via SMS. (e.g. "12345 activate") • The ID is used to additionally verify the incoming and outgoing messages and to activate the control commands.

Events that can be selected

You must set-up the events for which you receive notification.

Note

Selecting alarms

You have the option of selecting tool management type or measuring cycles alarms. This means that you obtain notification by SMS as soon as alarms are output, without having to know the number ranges.

Requirement

The modem is connected.

Procedure

Creating a new user



1. Press the "User profiles" softkey.
The "User Profiles" window appears.



2. Press the "New" softkey.

3. Enter the name and telephone number of the user.
4. If required, enter the ID number of the user.
5. In the area "send SMS for the following events" area, activate the appropriate checkbox and when required, enter the desired value (e.g. the unit quantity, which when it is reached, a notification should be sent).

- OR -



Press the "Default" softkey.

The appropriate window is opened and displays the default values.



6. Press the "Send test message" softkey.
An SMS message with predefined text is sent to the specified telephone number.

Editing user data and events



1. Select the user whose data you want to edit and press the "Edit" softkey.

The input fields can be edited.

2. Enter new data and activate the desired settings.

- OR -



Press the "Default" softkey to accept the default values.

18.4 Setting-up events

In the "Send SMS for the following events" area, select the events using the check box, which when they occur, an SMS is sent to the user.







- Programmed messages from the part program (MSG)
In the part program, program an MSG command via which you receive an SMS.
Example: MSG ("SMS: An SMS from a part program")
- Select the following events using the <SELECT> key
 - The workpiece counter reaches the following value
An SMS is sent if the workpiece counter reaches the set value.
 - The following program progress is reached (percent)
An SMS is sent if, when executing a part program, the set progress is reached.
 - Actual NC program reaches runtime (minutes)
An SMS is sent after the set runtime has been reached when executing an NC program.
 - Tool usage time reaches the following value (minutes)
An SMS is sent if the usage time of the tool reaches the set time when executing a part program (derived from \$AC_CUTTING_TIME).
- Messages/alarms from the Tool Manager
An SMS is sent if messages or alarms are output to the Tool Manager.
- Measuring cycle messages for tools
An SMS is sent if measuring cycle messages are output that involve tools.
- Measuring cycle messages for workpieces
An SMS is sent if measuring cycle messages are output that involve workpieces.
- Sinumerik messages/alarms (error when executing)
An SMS is sent if NCK alarms or messages are output that cause the machine to come to a standstill.

- Machine faults
An SMS is sent if PLC alarms or messages are output that cause the machine to come to a standstill (i.e. PLC alarms with Emergency Off response).
- Maintenance intervals
An SMS is sent if the service planner registers pending maintenance work.
- Additional alarm numbers:
Here, specify additional alarms where you should be notified if they occur.
You can enter individual alarms, several alarms or alarm number ranges.
Examples:
1234,400
1000-2000
100,200-300

Requirement

- The user profile window is opened.
- You selected the event "Measuring cycle messages for tools", "Measuring cycle messages for workpieces", "Sinumerik messages/alarms (errors when executing)", "Machine faults" or "Maintenance intervals".

Editing events

- | | |
|---|---|
|  | 1. Activate the required check box and press the "Details" softkey.
The appropriate window opens (e.g. "Measuring cycle messages for workpieces") and shows a list of the defined alarm numbers. |
|  | 2. Select the corresponding entry and press the "Delete" softkey to remove the alarm number from the list. |
| | - OR - |
|  | Then press the "New" softkey if you wish to create a new entry.
The "Create new entry" window opens. |
|  | Enter the data and press the "OK" softkey to add the entry to the list. |
|  | Press the "Save" softkey to save the settings for the result. |
|  | 3. Press the "Standard" softkey to return to the standard settings for the events. |

18.5 Logging an active user on and off

Only active users receive an SMS message for the specified events.

You can activate users, already created for Easy Message, with certain control commands via the user interface or via SMS.



The connection has been established to the modem.

Procedure



1. Press the "User profiles" softkey.



2. Select the desired user in the User name field and press the "User active" softkey



Note

Repeat step 2 to activate further users.

- OR -

Send an SMS with the User ID and the "activate" text to the control (e.g. "12345 activate")



If the telephone number and the user ID match the stored data, the user profile is activated.

You receive a message of success or failure per SMS.



3. Press the "User active" softkey to log off an activated user.





- OR -

Send an SMS with the "deactivate" text (e.g. "12345 deactivate") to log off from the Messenger.

An SMS message is not sent to the deactivated user for the events specified in the user profile.

18.6 Displaying SMS logs

The SMS data traffic is recorded in the "SMS Log" window. In this way, it is possible to see the chronological sequence of activates when a fault occurs.

Symbols	Description
	Incoming SMS message for the Messenger.
	Message that has reached the Messenger, but which has not been processed (e.g. incorrect user ID or unknown account).
	SMS message sent to a user.
	Message that has not reached the user because of an error.

Requirement



The connection has been established to the modem.

Procedure



1. Press the "SMS log" softkey.



The "SMS Log" window appears.

All the messages that have been sent or received by the Messenger are listed.

Note

Press the "Incoming" or "Outgoing" softkey to restrict the list.

18.7 Making settings for Easy Message

You can change the following Messenger configuration in the "Settings" window:

- Name of the controller that is part of an SMS message
- Number of sent messages
 - The SMS counter provides information on all sent messages.
 - Limit the number of sent messages in order to receive an overview of the costs through SMS messages, for example.

Setting the SMS counter to zero



When a set limit is reached, no further SMS messages are sent.
Press the "Reset SMS counter" softkey to reset the counter to zero.

Requirement



The connection has been established to the modem.

Procedure



1. Press the "Settings" softkey.

2. Enter an arbitrary name for the controller in the "Machine name" field.



3. If you want to limit the number of sent SMS messages then select the "Specify limit for SMS counter" entry and enter the desired number.

When the maximum number of messages is reached, you obtain a corresponding error message.

Note

Check the SMS log to see the exact time when the limit was reached.

- OR -



3. Press the "Default" softkey.

If you have freely selected a machine name, this is replaced by a default name (e.g. 828D).

Easy Extend (828D only)

19.1 Overview

Easy Extend enables machines to be retrofitted with additional units, which are controlled by the PLC or that require additional NC axes (such as bar loaders, swiveling tables or milling heads), at a later point in time. These additional devices are easily commissioned, activated, deactivated or tested with Easy Extend.

The communication between the operator component and the PLC is performed via a PLC user program. The sequences to be executed for the installation, activation, deactivation and testing of a device are stored in a statement script.

Available devices and device states are displayed in a list. The view of the available devices can be controlled for users according to their access rights.

The subsequent chapters are selected for example only and are not available in every statement list.



Machine manufacturer

Please refer to the machine manufacturer's specifications.

Up to 64 devices can be managed.

References

SINUMERIK 828D Turning and Milling Commissioning Manual

19.2 Enabling a device

The available device options are protected by a password.



Machine manufacturer

Please refer to the machine manufacturer's specifications.

Procedure

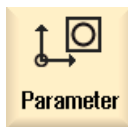

1. Select the "Parameter" operating area.



2. Press the menu forward key and then the "Easy Extend" softkey.
A list of the connected devices is displayed.

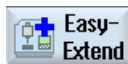

3. Press the "Enable function" softkey.
The "Enabling of the Devices Option" window is opened.



4. Enter the option code and press the "OK" softkey.
A tick appears in the appropriate checkbox in the "Function" column and the function is enabled.

19.3 Activating and deactivating a device

Status	Meaning
	Device activated
	System waiting for PLC checkback signal
	Device faulty
	Interface error in the communication module

Procedure



1. Easy Extend is opened.



2. You can select the desired device in the list with the <Cursor up> and <Cursor down> keys.



3. Position the cursor on the device option for which the function has been unlocked and press the "Activate" softkey.

The device is marked as activated and can now be used.



4. Select the desired activated device and press the "Deactivate" softkey to switch the device off again.

19.4 Commissioning Easy Extend

As a rule, the "Easy Extend" function has already been commissioned by the machine manufacturer. If a first commissioning has not been performed or if, for example, function tests are to be performed again (e.g. when retrofitting additional devices), this is possible at any time.

The "Start-up" softkey has been declared as Manufacturer data class (M).

Procedure

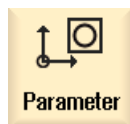

1. Select the "Parameter" operating area.



2. Press the menu forward key and then the "Easy Extend" softkey.

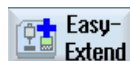

3. Press the "Start-up" softkey.
A new vertical softkey bar appears.



4. Press the "Comm. start-up" softkey to start the commissioning.
Before starting, a complete data backup is generated which you can then use in an emergency.

5. Press the "Cancel" softkey if you want to abort the commissioning prematurely.



6. Press the "Restore" softkey to load the original data.



7. Press the "Device function test" softkey to test the machine manufacturer's intended function.

Service Planner (828D only)

20.1 Performing and monitoring maintenance tasks

With the "Service Planner", maintenance tasks have been set up that have to be performed at certain intervals (e.g. top up oil, change coolant).

A list is displayed of all the maintenance tasks that have been set up together with the time remaining until the end of the specified maintenance interval.

The current status can be seen in the status display.

Messages and alarms indicate when a task has to be performed.

Acknowledging a maintenance task



Acknowledge the message when a maintenance task has been completed.

Note

Protection level

You require protection level 2 (service) to acknowledge completed maintenance tasks.

Service Planner

Display	Meaning	
Pos	Position of the maintenance task in the PLC interface.	
Maintenance task	Name of the maintenance task.	
Interval [h]	Maximum time until next servicing in hours.	
Remaining time [h]	Time until the interval expires in hours.	
Status	  	Display of the current status of a maintenance task. The maintenance task has been started. The maintenance task is completed. The maintenance task is deactivated.

Procedure



1. Select the "Diagnostics" operating area.



2. Press the menu forward key and then the "Service planner" softkey. The window with the list of all the maintenance tasks that have been set up appears.



3. Perform the maintenance task when the maintenance interval has nearly expired or when prompted to do so by alarms or a warning.



4. After you have performed a pending maintenance task and the task is signaled as "Completed", position the cursor at the appropriate task and press the "Servicing performed" softkey. A message is displayed confirming the acknowledgment, and the maintenance interval is restarted.

Note

You can perform the maintenance tasks before the interval expires. The maintenance interval is restarted.

20.2 Set maintenance tasks

You can make the following changes in the list of maintenance tasks in the configuration mode:

- Set up a maximum of 32 maintenance tasks with interval, initial warning and number of warnings to be acknowledged
- Change the interval, time of the initial warning and the number of warnings to be output
- Delete a maintenance task
- Reset the times of the maintenance tasks

Acknowledging a maintenance task



You can acknowledge the maintenance tasks with the "Servicing performed" softkey.

Note

Protection level

You require protection level 1 (manufacturer) to set up and edit maintenance tasks.

Service Planner

Display	Meaning	
Pos	Position of the maintenance task in the PLC interface.	
Maintenance task	Name of the maintenance task.	
Interval [h]	Maximum time until next servicing in hours.	
1. warning [h]	Time in hours at which an initial warning is displayed.	
Number of warnings	Number of warnings that can be acknowledged by the operator before an alarm message is output for the last time.	
Remaining time [h]	Time until the interval expires in hours. The remaining time cannot be edited.	
Status	  	Display of the current status of a maintenance task. The maintenance task has been started. The maintenance task is completed. The maintenance task is deactivated, i.e. the time has been stopped.
	The status cannot be edited.	

Procedure



1. Select the "Diagnostics" operating area.



2. Press the menu forward key and then the "Service planner" softkey. The window opens and displays a list of all the tasks that have been set up.



The values cannot be edited.



3. Press the "New maintenance task" softkey to set up a new maintenance task.

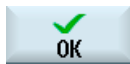

A message informs you that a new maintenance task will be set up at the next free position. Enter the required data in the columns and press the "OK" softkey.

- OR -



Position the cursor on the desired maintenance task and press the "Change task" softkey to change the associated times.

All columns except Remaining time and Status can be edited.

- OR -



Press the "Reset all" softkey to reset all the times.

- OR -



Position the cursor on the desired maintenance task and press the "Delete task" softkey to remove the maintenance task from the list.

Ladder Viewer and Ladder add-on (828D only)

21.1 PLC diagnostics

A PLC user program consists to a large degree of logical operations to implement safety functions and to support process sequences. These logical operations include the linking of various contacts and relays. These logic operations are displayed in a ladder diagram.

21.2 Structure of the user interface

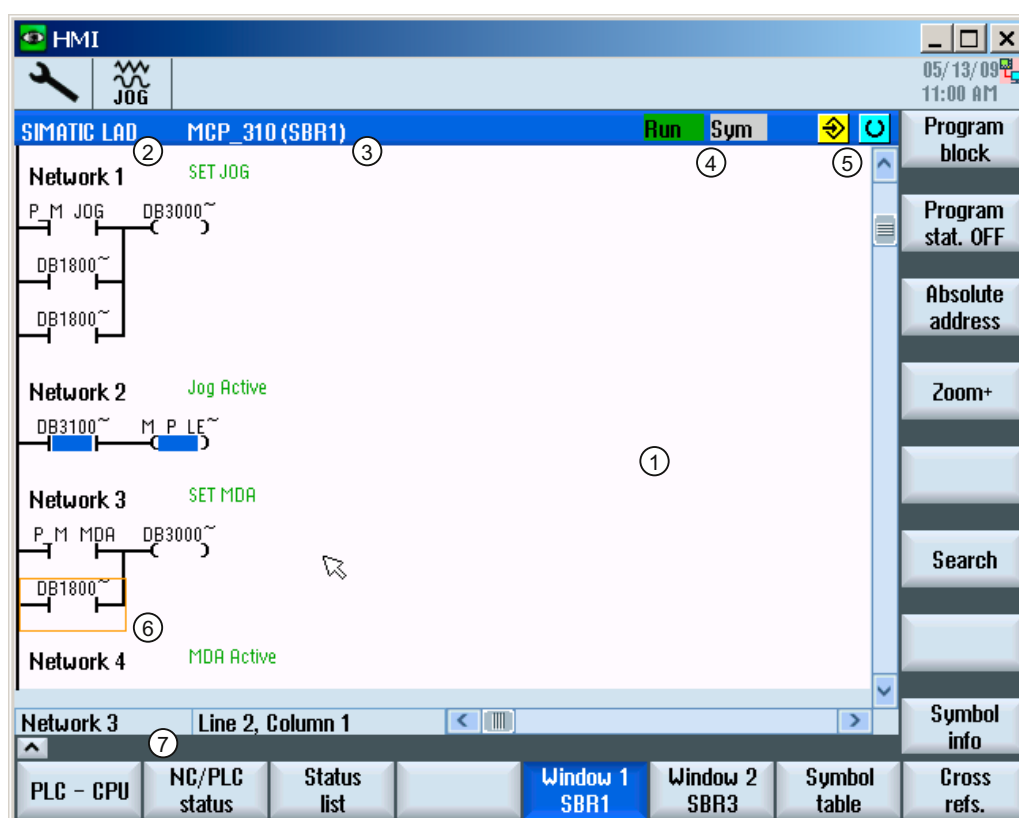



Figure 21-1 Screen structure

21.3 Control options

Table 21- 1 Key to screen layout



Screen element	Display	Meaning
1	Application area	
2	Supported PLC program language	
3	Name of the active program block Representation: Symbolic name (absolute name)	
4	Program status 	
	Run	Program is running
	Stop	Program is stopped
	Status of the application area	
	Sym	Symbolic representation
	Abs	Absolute representation
5	Display of the active keys (<INPUT>, <SELECT>) 	
6	Focus Performs the tasks of the cursor	
7	Information line Displays information, e.g. for searching	























21.3 Control options

In addition to the softkeys and the navigation keys, there are further shortcuts in this area.

Shortcuts

The cursor keys move the focus over the PLC user program. When the window borders are reached, scrolling is performed automatically.

Shortcuts	Action
	To the first column of the row
CTRL 	
END	To the last column of the row

Shortcuts		Action
		
		Up a screen
		Down a screen
		One field to the left, right, up or down
		
		To the first field of the first network
-or-		
		
		To the last field of the last network
-or-		
		
		Open the next program block in the same window
		Open the previous program block in the same window
		<p>The function of the Select key depends on the position of the input focus.</p> <ul style="list-style-type: none"> • Table line: Displays the complete text line • Network title: Displays the network comment • Command: Displays all operands
		If the input focus is positioned on a command, all operands including the comments are displayed.

21.4 Displaying PLC properties

The following PLC properties can be displayed in the "SIMATIC LAD" window:

- Operating state
- Name of the PLC project
- PLC system version
- Cycle time
- Machining time of the PLC user program

Procedure

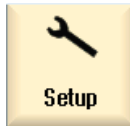

1. Select the "Start-up" operating area.



2. Press the "PLC" softkey.
The ladder diagram display opens and displays the PLC information.



3. Press the "Reset mach.time" softkey.
The data of the machining time is reset.

21.5 Displaying and editing NC/PLC variables

The "NC/PLC Variables" window enables the monitoring and modification of NC system variables and PLC variables.

You receive the following list in which you enter the desired NC and PLC variables in order to display the actual values.

- Variable
Address for NC/PLC variable.
Faulty variables have a red background and # is displayed in the Value column.
- Comment
Arbitrary comment on the variables.
The column can be shown or hidden.
- Format
Specification of the format in which the variable is to be displayed.
The format can be permanently defined (e.g. floating-point).
- Value
Display of the current value of the NC/PLC variable.

Procedure



1. Ladder add-on tool is opened.



2. Press the "NC/PLC variables" softkey.
The "NC/PLC Variables" window appears.

21.6 Displaying and editing PLC signals

PLC signals are displayed and can be changed here in the "PLC status list" window.

The following lists are shown

Inputs (IB)

Bit memories (MB)

Outputs (QB)

Variables (VB)

Data (DB)







Setting the address

You can go directly to the desired PLC address to monitor the signals.

Editing

You can edit the data.

Procedure

- | | |
|---|---|
|  | 1. Ladder add-on tool is opened. |
|  | 2. Press the "Status list" softkey.
The "Status List" window appears. |
|  | 3. Press the "Set address" softkey.
The "Set Address" window appears. |
|  | 4. Activate the desired address type (e.g. DB), enter the value and press the "OK" softkey.
The cursor jumps to the specified address. |
|  | 5. Press the "Change" softkey.
The "RW" input field can be edited. |
|  | 6. Enter the desired value and press the "OK" softkey. |

21.7 Displaying information on the program blocks

You can display all the logic and graphic information of a program block.

Display program block

In the "Program block" list, select the program block that you want to display.

Logic information

The following logic information is displayed in a ladder diagram (LAD):

- Networks with program parts and current paths
- Electrical current flow through a number of logical operations

Further information

- Properties

Name of the block, author, number of the subprogram, data class, date it was generated, date of the last change and comment.

- Local variable

Name of the variable, variable type, data type and comment.

Access protection



If a program block is password-protected. The ladder diagram display can be enabled using the "Protection" softkey.

Displaying the program status

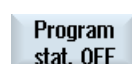

1. Press the "Program stat. OFF" softkey to hide the program status in the status display.

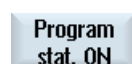

2. Press the "Program stat. ON" softkey to unhide the program status in the status display.

Display progress status

If your PLC has the function "Progress status" available, the status values are displayed at the time of execution of the operations. The status of the local data memory and the accumulators is also displayed.

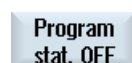

1. Press the "Program stat. OFF" softkey to hide the program status in the status display.

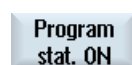

2. Press the "Program stat. ON" softkey to unhide the program status in the status display.

Change colors for displaying of progress or program status

In progress status, different colors are used to display information.

Display	Color
Signal flow of power rail, when status active	Blue
Signal flow in the networks	Blue
All operations that are active and that are executed without error (corresponds to signal flow)	Blue
Status of the Boolean operations (corresponds to signal flow)	Blue
Times and counters active	Green
Error during execution	Red
No signal flow	Gray
No network executed	Gray
STOP mode	Gray

Note

Colored display in program status

In the display of the program status only the color of the signal flow is relevant.

Enlarging/reducing the display of the ladder diagram



1. Press the "Zoom +" softkey to enlarge the section of the ladder diagram.

After enlarging, the "Zoom -" softkey is available.



2. Press the "Zoom -" softkey to reduce the section of the ladder diagram again.

Procedure



1. Ladder add-on tool is opened.



2. Press the "Window 1" or "Window 2" softkey.

...



3. Press the "Program block" softkey.
The "Program block" list is displayed.



4. Press the "Properties" softkey if you wish to display additional information.

- OR -



Press the "Local variables" softkey if you wish to display data of a variable.

21.8 Loading modified PLC user program

Download the project data into the PLC if some changes have been made to the project data and a new PLC user program is available.

When the project data is loaded, the data classes are saved and loaded to the PLC.

Requirement

Check whether the PLC is in Stop mode.

Note

PLC in RUN mode

If the PLC is in RUN mode, a corresponding message is displayed and the "Load in Stop" and "Load in Run" softkeys appear.

With "Load in Stop", the PLC is set to Stop mode and the project is stored and loaded to the CPU.

With "Load in Run", the loading operation is continued and the PLC project loaded to the PLC. Only those data classes that have really been changed are loaded, i.e. generally INDIVIDUAL data classes.

Procedure



1. Ladder add-on tool is opened.
You have changed project data.



2. Press the "PLC Stop" softkey if the PLC is in the run mode.



3. Press the "Load to CPU" softkey to start the loading operation.
All data classes are loaded.



4. When the PLC project has been loaded, press the "PLC Start" softkey to switch the PLC to Run mode.

21.9 Editing the local variable table

You have the option of editing the local variable table of an INT block.

Insert local variable

If you have inserted new networks or operands, it may be necessary to insert new variables in the local variable table of an INT block.

Name	Freely assign.
Variable type	Selection: <ul style="list-style-type: none">• IN• IN_OUT• OUT• TEMP
Data type	Selection: <ul style="list-style-type: none">• BOOL• BYTE• WORD• INT• DWORD• DINT• REAL
Comment	Freely assign.

Procedure



...



1. The ladder diagram display (LAD) is opened.
2. Press the "Program block" softkey.
3. Press the "Local variables" softkey.
The "Local Variables" window appears and lists the created variables.
4. Press the "Edit" softkey.
The fields can be edited.
5. Enter a name, select the variable and data type and, if required, enter a comment.
6. Press the "Attach line" softkey if you want to add a further variable and enter the data.

- OR -
Select the relevant variable and press the "Delete line" softkey to remove the variable from the list.

21.10 Creating a new block

Create INT blocks to make changes in the PLC user program.

Name	INT_100, INT_101 The number from the selection field "Number of subprogram" is taken for the name of the INT block.
Author	A maximum of 48 characters is permitted.
Number of subprogram	100, 101
Data class	Individual
Comment	A maximum of 100 lines and 4096 characters are permitted.

Note

Access protection

You have the option of protecting blocks that have been newly created against being accessed.

Procedure



...



1. The ladder diagram display (LAD) is opened.
2. Press the "Program block" softkey to open the list of program blocks.
3. Press the "Add" softkey.
The "Properties" window appears.
4. Enter author, number of the INT block and, if required, a comment.
The data class of the block is specified.
5. Press the "OK" softkey to transfer the block to the list.

21.11 Editing block properties subsequently

You can edit the title, author and comments of an INT block.

Note

You cannot edit the block name, subprogram number and data class assignment.

Procedure



1. The ladder diagram display is opened.



2. Select the relevant block and press the "Program block" softkey.



3. Press the "Properties" softkey.
The "Properties" window appears.

21.12 Inserting and editing networks

You can create a new network and then insert operations (bit operation, assignment, etc.) at the selected cursor position.

Only empty networks can be edited. Networks, that already include statements, can only be deleted.

A simple, single line can be edited for each network. You can create a maximum of 3 columns per network.

Column	Operation	
Column 1	<ul style="list-style-type: none"> • NO contact • NC contact 	- - - / -
Column 2 (optional)	NOT Rising edge Falling edge Assign Set Reset	- NOT - - P - - N - -() -(S) -(R)
Column 3 (only possible if no assign, set or reset operations were specified in the second column)	Assign Set Reset	-() -(S) -(R)

Note

Logical AND (serial contact) and logical OR (parallel contact) are not possible.

The bit combinations comprise one or several logical operations and the assignment to an output / bit memory.

If the cursor is moved further to the left with the arrow key, the type of assignment or a logic operation can be selected. A further logic operation cannot be placed to the right of an assignment. A network must always be terminated with an assignment.

References

For further information about PLC programming, please refer to:

Function Manual Basic Functions, PLC for SINUMERIK 828D (P4)

Procedure

1. An INT100 or INT101 routine has been selected.



2. Press the "Edit" softkey.



3. Position the cursor on a network.
4. Press the "Insert network" softkey.

- OR -



Press the <INSERT> key.

If the cursor is positioned on "Network x", a new, empty network is inserted behind this network.



5. Position the cursor on the desired element below the network title and press the "Insert operation" softkey.

The "Insert Operation" window appears.



6. Select the desired bit operation (NC contact or NO contact) or assignment and press the "OK" softkey.



7. Press the "Insert operand" softkey.



8. Enter the logic operation or the command and press the <INPUT> key to complete the entry.



9. Position the cursor on the operation that you want to delete and press the "Delete operation" softkey.

- OR -



Position the cursor on the title of the network that you want to delete and press the "Delete network" softkey.

- OR -



Press the key.

The network, including all the logic operations and operands, or the selected operation is deleted.

21.13 Editing network properties

You can edit the network properties of an INT block.

Network title and network comment

The title can have a maximum of three lines and 128 characters. The comment can have a maximum of 100 lines and 4096 characters.

Procedure



1. The ladder diagram display (LAD) is opened.



2. Use the cursor keys to select the network that you want to edit.



3. Press the <SELECT> key.
The "Network title / comment" window opens and shows the title and a possibly assigned comment for the selected network.



5. Press the "Change" softkey.
The fields can be edited.











6. Enter the changes and press the "OK" softkey to transfer the data to the user program.

21.14 Displaying and editing symbol tables

You can display the symbol tables that are used to obtain an overview of the global operands available in the project - which you can then edit.

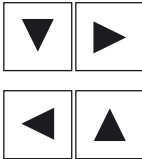
The name, address and possibly also a comment is displayed for each entry.

Procedure

- | | |
|---|--|
|  | 1. Ladder add-on tool is opened. |
|  | 2. Press the "Symbol table" and the "Select sym. table" softkeys. The list with the symbol table entries is displayed. |
|  | |
|  | 3. Select the desired table and press the "Open" softkey. The display fields can be edited. |
|  | 4. Use the cursor keys to select the desired entry and the field to be changed. |
|  | 5. Enter the value to be changed.
- OR -
Press the "Attach line" softkey to insert an empty line after the selected entry.
- OR - |
|  | |
|  | 6. Press the "OK" softkey to confirm your action. |

21.15 Inserting/deleting a symbol table







New user symbol tables can be generated and changed. Tables that are no longer used can be deleted.

Note

Delete symbol table

The "Delete" softkey is only available if a user symbol table has been selected.

Procedure

- | | |
|---|--|
|  | 1. The symbol table is opened. |
|  | 2. Press the "Select sym. table" softkey.
The "Symbol Table - Selection" window appears. |
|  | 3. Position the cursor at the desired position and press the "Insert sym. table" softkey.
The "Create Symbol Table" window appears. |
|  | 4. Enter a symbolic name and press the "OK" softkey.
The new user symbol table is inserted in the line after the cursor position.
- OR - |
|  | Select a symbol table and press the "Change symbol table" softkey if you wish to change the properties of the symbol table. |
|  | 5. Position the cursor on the symbol table that you want to delete and press the "Delete" softkey. |

21.16 Searching for operands

You can use the search function to quickly reach points in very large programs where you would like, for example, to make changes.

Restricting the search

- "Window 1" / "Window 2", "Symbol table"

With "Go to", you can jump directly to the desired network.







- "Cross references"

With "Go to", you can jump directly to the desired line.

Requirement

Window 1 / window 2, the symbol tables or the list of cross references is opened.

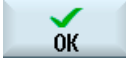
Procedure

- | | |
|---|---|
|  | 1. Press the "Find" softkey.
A new vertical softkey bar appears. The "Find / Go To" window opens at the same time. |
|  | 2. Select the "Find operand" entry in the first input field if you are searching for a specific operand and enter the search term in the "Find" input field. |
|  | 3. Select the search range (e.g. Find all). |
|  | 4. Select the "In this program unit" or "In all program units" entry if you are in "Window 1" or "Window 2" or in the symbol table in order to restrict the search. |
|  | 5. Press the "OK" softkey to start the search.
If the operand you are searching for is found, the corresponding line is highlighted. |
|  | Press the "Continue search" softkey if the operand found during the search does not correspond to the element you are looking for. |
| - OR - | |
|  | Press the "Cancel" softkey if you want to cancel the search. |

Further search options



1. Press the "Go to start" softkey to jump to the start of the ladder diagram in window 1 or window 2, or the list (cross references, symbol table).



2. Press the "Go to end" softkey to jump to the end of the ladder diagram in window 1 or window 2, or the list (cross references, symbol table).

21.17 Displaying the network symbol information table

All of the symbolic identifiers used in the selected network are displayed in the "Network symbol information table" window.

The following information is listed:

- Names
- Absolute addresses
- Comments

The symbol information table remains empty for networks that do not contain any global symbols.

Procedure



1. The ladder diagram display (LAD) is opened.



2. Select the desired network and press the "Symbol info" softkey. The "Network Symbol Information Table" window appears.



3. Use the cursor keys to move within the table.







21.18 Displaying/canceling the access protection

You can password protect your program organizational units (POUs) in the PLC 828 programming tool. This prevents other users from accessing this part of the program. This means that it is invisible to other users and is encrypted when it is downloaded.

A lock symbol is used to show a password-protected POU in the block overview and in the ladder diagram.

Procedure

- | | | |
|---|----|--|
|  | 1. | The ladder diagram display (LAD) is opened. |
|  | | |
|  | 2. | Select the relevant program organizational unit (POU) in the overview and press the "Program block" softkey. |
|  | 3. | Press the "Protection" softkey.
The "Protection" window appears. |
|  | 4. | Enter your password and press the "Accept" softkey. |

21.19 Displaying cross references

You can display all the operands used in the PLC user project and their use in the list of cross references.

This list indicates in which networks an input, output, bit memory etc. is used.

The list of cross references contains the following information:

- Block
- Address in the network
- Context (command ID)

Symbolic and absolute address

You can choose between specification in absolute or symbolic address.

Elements for which there are no symbolic identifiers are automatically displayed with absolute identifiers.

Opening program blocks in the ladder diagram











From the cross references, you have the option of going directly to the location in the program where the operand is used. The corresponding block is opened in window 1 or 2 and the cursor is set to the corresponding element.

Searching

Using a specific search, you can go directly to the location that you wish to view in more detail:

- Search for operand
- Jump to sought line

Procedure

- | | |
|---|--|
|  | 1. Ladder add-on tool is opened. |
|  | 2. Press the "Cross refs." softkey.
The list of cross references appears and the operands are displayed sorted according to absolute address. |
|  | 3. Press the "Symbol. address" softkey.
The list of operands is displayed sorted according to symbolic address. |
|  | 4. Press the "Absolute address" softkey to return to the display showing the absolute addresses. |
|  | 5. Select the desired cross reference and press the "Open in window 1" or "Open in window 2" softkey. |
|  | The ladder diagram is opened, and the selected operand is marked. |
|  | 6. Press the "Find" softkey.
The "Find / Go To" window appears. |
|  | 7. Select "Find operand" or "Go to" and enter the sought element or the desired line and select the search order (e.g. search up). |
|  | 8. Press the "OK" softkey to start the search. |
|  | 9. If an element is found that corresponds to the sought element, but is not at the appropriate position, press the "Continue search" softkey to find where the search term occurs next. |

Appendix

A.1 840D sl documentation overview

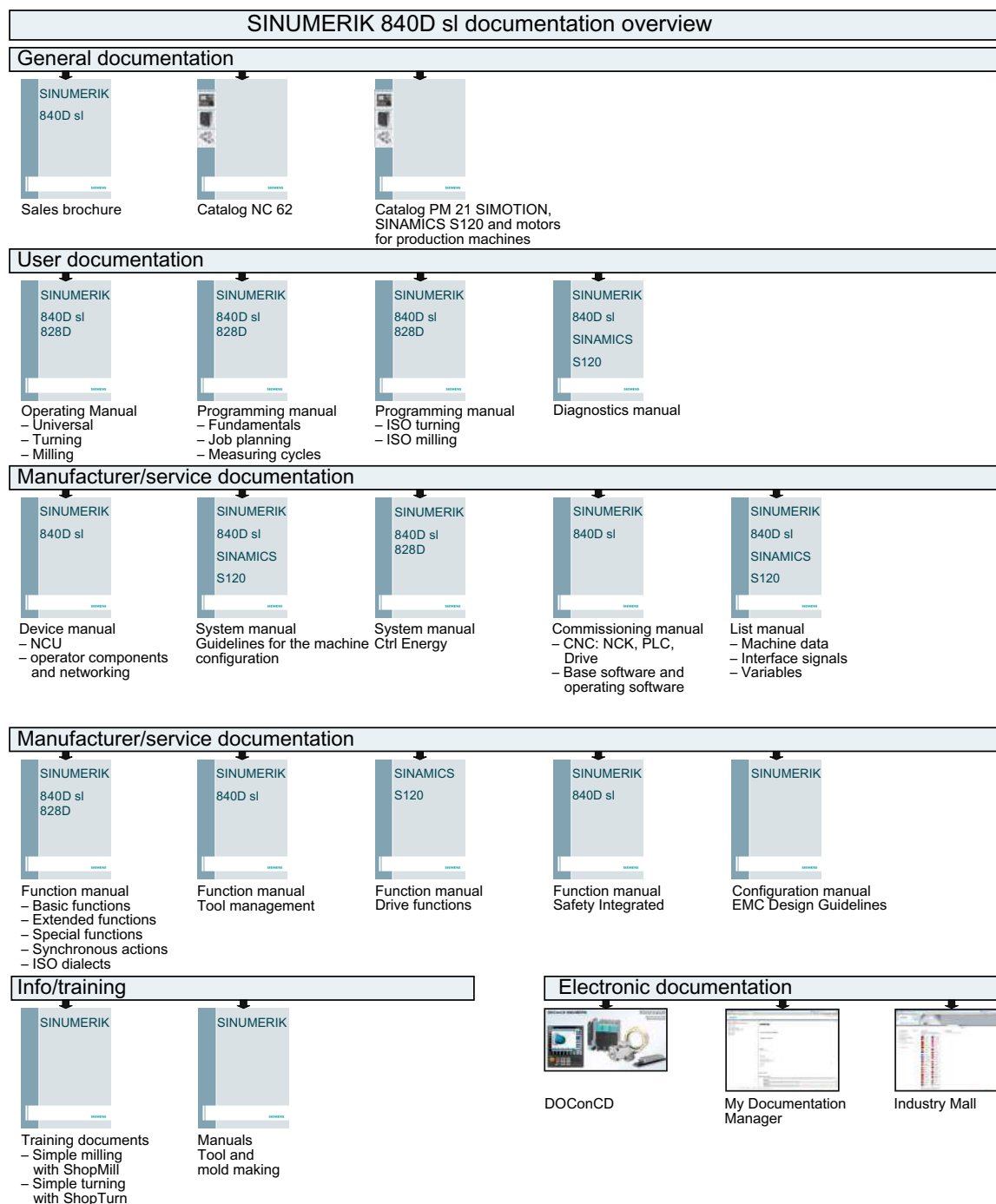

Index

A

- Actual-value display, 38
- Adapter-transformed view, 568
- Alarm log
 - display, 629
 - Sorting, 631
- Alarms
 - Displaying, 627
 - Sorting, 631
- Aligning milling tool - CYCLE800
 - Function, 487
 - Parameters, 488
- Angular milling
 - Manual Machine, 654
- Any file
 - Creating, 585
- Arbitrary positions - CYCLE802
 - Function, 324
 - Parameter, 326
- Archive
 - Generate in the program manager, 607
 - generating in the system data, 608
 - Punched tape format, 607
 - read in archive from system data, 612
 - reading-in in the Program Manager, 610
- Asian characters, 50
- Auxiliary functions
 - H functions, 196
 - M functions, 196
- Axes
 - Defined increment, 134
 - Direct positioning, 136
 - Referencing, 60
 - Repositioning, 157
 - Traversing, 134
 - Variable increment, 135

B

- Backing up
 - Data - in the Program Manager, 607
 - Data - via the system data, 608
 - Setup data, 613
- Base offset, 113

Milling

Operating Manual, 03/2013, 6FC5398-7CP40-3BA1

- Basic blocks, 154
- Binary format, 607
- blank
 - Change, 270
- Blank input
 - Function, 238
 - Parameter, 239
- Block
 - Searching, 159
 - Searching - interruption point, 162
 - Searching - search pointer, 163
- Block search
 - Mode, 165
 - Program interruption, 162
 - Search pointer, 163
 - Search target parameters, 164
 - Search target specification, 161
 - Using, 158
- Boring - CYCLE86
 - Function, 309
 - Parameter, 311

C

- Calculator, 47
- Centering - CYCLE81
 - Function, 300
 - Parameter, 301
- Change
 - Blank, 270
- Channel switchover, 65
- Circle
 - Manual Machine, 657
 - Polar, 509
 - With known center point - function, 504
 - With known center point - parameter, 505
 - With known radius - function, 505
 - With known radius - parameter, 506
- Circle position pattern - HOLES2
 - Function, 329
- Circular pocket - POCKET4
 - Function, 341
 - Parameter - input complete, 346
- Circular position pattern - HOLES2
 - Parameter, 330
- Circular spigot - CYCLE77
 - Function, 350
 - Input simple, 350

- Parameter - input complete, 352
- Circumferential slot - SLOT2
 - Function, 360
 - Parameter - input complete, 363
- Coarse and fine offsets, 113
- Code carrier connection, 545
- Collision avoidance, 519
- Context-sensitive online help, 54
- Contour call - CYCLE62
 - Function, 454
 - Parameter, 455
- Contour milling
 - Manual Machine, 662
- Contour pocket residual material - CYCLE63
 - Function, 406
 - Parameters, 407
- Contour spigot residual material - CYCLE63
 - Function, 410
 - Parameters, 411
- Contour turning
 - Overview, 443
- Coordinate system
 - Switching over, 67
- Coordinate transformation, 493
- Copying
 - Directory, 594
 - Program, 594
- Creating
 - Any file, 585
 - Directory, 581
 - G code program, 583
 - Job list, 586
 - NC directory on the local drive, 575
 - Program block, 178
 - Program list, 587
 - Workpiece, 582
- Ctrl-Energy
 - Energy analysis, 686
 - Energy-saving profiles, 690
 - Functions, 685
 - Measuring the energy consumption, 687
 - Saved measuring curves, 689
- Cut-off - CYCLE92
 - Function, 441
 - Parameter, 442
- CYCLE60 - Engraving
 - Function, 377
 - Parameters, 382
- CYCLE61 - Face milling
 - Function, 334
 - Parameters, 336
- CYCLE62- contour call
 - Function, 454
 - Parameter, 455
- CYCLE63 - Contour pocket residual material
 - Function, 406
 - Parameters, 407
- CYCLE63 - Contour spigot residual material
 - Function, 410
 - Parameters, 411
- CYCLE63 - Milling contour pocket
 - Parameter - input complete, 405
- CYCLE63 - Milling contour spigot
 - Function, 408
 - Parameter - input complete, 409
- CYCLE64 - Predrilling contour pocket
 - Function - Centering, 400
 - Function - Predrilling, 400
 - Parameter - Centering, 402
 - Parameter - Predrilling, 403
- CYCLE70 - thread milling
 - Function, 373
 - Parameter, 376
- CYCLE72 - Path milling
 - Function, 394
 - Parameter, 398
- CYCLE76 - rectangular spigot
 - Function, 347
 - Parameter - input complete, 349
- CYCLE77 - circular spigot
 - Function, 350
 - Input simple, 350
 - Parameter - input complete, 352
- CYCLE78 - Drill thread milling
 - Function, 317
 - Parameter, 320
- CYCLE79 - multi-edge
 - Function, 353
 - Parameter - input complete, 355
- CYCLE800 - Aligning milling tool
 - Function, 487
 - Parameters, 488
- CYCLE800 - Setting milling tool
 - Function, 485
 - Parameters, 486
- CYCLE800 - Swiveling
 - Function, 475
 - Parameters, 482
- CYCLE801 - grid/frame position pattern
 - Function, 327
 - Parameter, 328
- CYCLE802 - arbitrary positions
 - Function, 324
 - Parameter, 326

- CYCLE81 - centering
 - Function, 300
 - Parameter, 301
 - CYCLE82 - drilling
 - Function, 302
 - Parameter input complete, 303
 - CYCLE83 - deep-hole drilling
 - Function, 305
 - Parameter, 308
 - CYCLE832 - High Speed Settings
 - Function, 488
 - Parameters, 491
 - CYCLE84 - rigid tapping
 - Function, 311
 - Parameter, 316
 - CYCLE840 - tapping with compensating chuck
 - Function, 311
 - Parameter, 316
 - CYCLE85 - reaming
 - Function, 304
 - Parameter, 305
 - CYCLE86 - boring
 - Function, 309
 - Parameter, 311
 - CYCLE899 - Milling open slot
 - Parameter - input complete, 370
 - CYCLE899 - open slot
 - Function, 363
 - CYCLE92 - cut-off
 - Function, 441
 - Parameter, 442
 - CYCLE930 - groove
 - Function, 417
 - Parameter, 421
 - CYCLE940 - Undercut
 - Function - DIN thread, 426
 - Function - Form E, 422
 - Function - Form F, 422
 - Function - Thread, 426
 - Parameter - DIN thread, 427
 - Parameter - Form E, 424
 - Parameter - Form F, 425
 - Parameter - Thread, 428
 - CYCLE951 - stock removal
 - Function, 412
 - Parameter, 416
 - CYCLE952 - Grooving
 - Function, 464
 - Parameter - input complete, 467
 - CYCLE952 - Grooving residual material
 - Function, 467
 - Parameters, 469
 - CYCLE952 - Plunge turning
 - Function, 469
 - Parameter - input complete, 472
 - CYCLE952 - Plunge turning residual material
 - Function, 472
 - Parameters, 474
 - CYCLE952 - Stock removal
 - Function, 455
 - Parameter - input complete, 460
 - CYCLE952 - Stock removal residual material
 - Function, 461
 - Parameters, 463
 - CYCLE98 - thread chain
 - Function, 438
 - Parameter - input simple, 440
 - CYCLE99 - face thread
 - Parameter - input complete, 435
 - CYCLE99 - longitudinal thread
 - Parameter - input complete, 433
 - CYCLE99 - tapered thread
 - Parameter - input complete, 437
 - CYCLE99 - Thread turning
 - Function - Face thread, 429
 - Function - Longitudinal thread, 429
 - Function - Tapered thread, 429
 - Cycles
 - Current levels, 235
 - Hiding cycle parameters, 245
 - Screen forms, 235
 - Cylinder surface transformation
 - Function, 498
 - General programming, 499
 - Parameters, 500
- ## D
- Data block (SB2), 152
 - Deep-hole drilling - CYCLE83
 - Function, 305
 - Parameter, 308
 - Deleting
 - Directory, 596
 - Program, 596
 - Device
 - Activate/deactivate, 704
 - Enabling, 704
 - Directory
 - Copying, 594
 - Creating, 581
 - Deleting, 596
 - Highlight, 592
 - Pasting, 594

- Properties, 597
 - Selecting, 592
- Displaying
 - Energy consumption, 686
 - HTML documents, 603
 - PDF documents, 603
 - Program level, 155
- DRF (handwheel offset), 167
- Drill thread milling - CYCLE78
 - Function, 317
 - Parameter, 320
- Drilling
 - Manual Machine, 660
- Drilling - CYCLE82
 - Function, 302
 - Parameter input complete, 303
- Drive
 - Error messages, 601
 - Logical drive, 599
 - Setting up, 599
- DRY (dry run feed), 167
- Dual editor, 179
- Duplo number, 534

E

- Easy Extend, 703
 - Activate/deactivate device, 704
 - Enabling a device, 704
 - First commissioning, 705
- Easy Message, 693
 - Commissioning, 694
 - Settings, 701
 - User log on/off, 699
- Edges
 - Managing, 540
- Editor
 - Calling, 172
 - Settings, 181
- Elongated hole - LONGHOLE
 - Function, 371
 - Parameter, 372
- Enabling button, 678
- Energy consumption
 - Displaying, 686
 - Measuring, 687
- Energy-saving profiles, 690
- Engraving - CYCLE60
 - Function, 377
 - Parameter, 382
- Executing
 - Program, 580

- EXTCALL call, 604

F

- Face milling
 - in JOG, 144
- Face milling - CYCLE61
 - Function, 334
 - Parameter, 336
- Face milling in JOG
 - Parameter, 146
- Face thread - CYCLE99
 - Parameter - input complete, 435
- Feed data
 - Actual value window, 41

G

- G code program
 - Blank input, 238
 - Creating, 583
- G functions
 - Display all G groups, 193
- G Functions
 - Displaying selected G groups, 191
- GCC (G code converter), 167
- Global user variables, 185
- Graphic tool display, 558
- Graphic view
 - ShopMill, 250
- Grid/frame position pattern - CYCLE801
 - Function, 327
 - Parameter, 328
- Groove - CYCLE930
 - Function, 417
 - Parameter, 421
- Grooving - CYCLE952
 - Function, 464
 - Parameter - input complete, 467
- Grooving residual material - CYCLE952
 - Function, 467
 - Parameters, 469

H

- Handheld terminal 8, 677
- Handwheel
 - Assigning, 123
- Helix, 506
- High Speed Settings - CYCLE832
 - Function, 488

- Parameters, 491
- Highlight
 - Directory, 592
 - Program, 592
- High-Speed Cutting, 194
- HOLES1 - line position pattern
 - Function, 327
 - Parameter, 328
- HOLES2 - circle position pattern
 - Function, 329
 - Parameter, 330
- HSC information, 194
- HT 8
 - Enabling button, 678
 - Overview, 677
 - Touch Panel, 684
 - Traversing keys, 680
 - User menu, 681
 - Virtual keyboard, 682
- HTML documents
 - Displaying, 603

I

- Input simple
 - Circular spigot - CYCLE77, 350
- Interruption point
 - Approaching, 162

J

- Job list
 - Creating, 586

L

- Ladder viewer, 711
- Limit stops, 652
- Line position pattern - HOLES1
 - Function, 327
 - Parameter, 328
- Logbook
 - Delete entries, 641
 - Displaying, 641
 - Edit the address data, 641
 - Entry search, 643
 - Making an entry, 642
 - Output, 639
 - Overview, 640
- LONGHOLE - elongated hole
 - Function, 371

- Parameter, 372
- Longitudinal slot - SLOT1
 - Function, 355
 - Parameter - input complete, 359
- Longitudinal thread - CYCLE99
 - Parameter - input complete, 433

M

- Machine control panel
 - Operator controls, 31
- Machine functions, 264
- Machine model, 519
- Machine-specific information
 - Save, 639
- Machining
 - Canceling, 150
 - Starting, 149
 - Stopping, 149
- Machining step program, 249
- Magazine
 - Open, 553
 - Positioning, 555
 - Selecting, 544
- Magazine management, 524
- Maintenance tasks
 - Monitoring/performing, 707
 - Setting up, 709
- Manual Machine, 649
 - Angular milling, 654
 - Circle, 657
 - Contour milling, 662
 - Drilling, 660
 - Manual mode, 653
 - Measuring the tool, 650
 - Milling, 661
 - Set limit stop, 652
 - Simulating, 663
 - Single-cycle machining, 658
 - Straight line, 655
 - Traversing axes, 653
 - Work offset, 651
 - Workpiece zero, 650
- Manual mode, 129
 - Circle, 657
 - Positioning axes, 136
 - Settings, 147
 - Spindle, 132
 - Straight line, 655
 - T, S, M windows, 129
 - Tool, 131
 - Traversing axes, 134

- Unit of measurement, 129
- Manually
 - Retracting, 142
 - Swiveling, 137
- MDA
 - Deleting a program, 128
 - Executing a program, 128
- MDI
 - Loading a program, 126
 - Saving a program, 127
- Measuring
 - Tool, 71
 - Tool automatically, 75
 - Tool manually, 71
 - Workpiece zero, 78
- Measuring the tool
 - Manual Machine, 650
- Messages
 - Displaying, 630
 - Sorting, 631
- Milling
 - Manual Machine, 661
- Milling contour pocket - CYCLE63
 - Parameter - input complete, 405
- Milling contour spigots - CYCLE63
 - Function, 408
 - Parameter - input complete, 409
- Milling open slot - CYCLE899
 - Parameter - input complete, 370
- Mode groups, 65
- Mold making
 - G functions, 194
- Mold making view
 - Changing a graphic, 203
 - Changing the section, 204
 - Editing a program block, 202
 - Programs, 198
 - Searching for program blocks, 202
 - Starting, 201
- Multi-channel view, 511
 - "Machine" operating area, 511
 - Settings, 516
- Multi-edge - CYCLE79
 - Function, 353
 - Parameter - input complete, 355
- Multiple clamping, 622
 - Program creation, 624
 - Settings in the program header, 623

N

- NC directory

- creating on local drive, 575
- NC/PLC variables
 - Changing, 634
 - Displaying, 632
 - Load symbols, 637
- New contour
 - Function - Milling, 385
 - Function - Turning, 445
 - Parameter - Milling, 386
 - Parameter - Turning, 447
- Number of teeth, 535

O

- Obstacle
 - Function, 510
 - Parameter, 510
- Offset, 494
- Online help
 - Context-sensitive, 54
- Open
 - Program, 578
 - Second program, 179
- Open slot - CYCLE899
 - Function, 363
- Operating area
 - Changing, 43
- Operating mode
 - AUTO, 64
 - Changing, 43
 - JOG, 129
 - MDI, 64
 - REPOS, 63
 - TEACH IN, 64
- Operator panel fronts, 20

P

- Parameter
 - Calculating, 45
 - Changing, 45
 - Entering, 44
 - Face milling in JOG, 146
- Pasting
 - Directories, 594
 - Program, 594
- Path milling - CYCLE72
 - Function, 394
 - Parameter, 398
- PDF documents
 - Displaying, 603

- Pinyin
 - Input editor, 50
 - Pitch, 534
 - PLC diagnostics
 - Ladder add-on tool, 711
 - PLC symbols
 - Loading, 637
 - Plunge turning - CYCLE952
 - Function, 469
 - Parameter - input complete, 472
 - Plunge turning residual material - CYCLE952
 - Function, 472
 - Parameters, 474
 - POCKET3 - rectangular pocket
 - Function, 337
 - Parameter - input complete, 341
 - POCKET4 - circular pocket
 - Function, 341
 - Parameter - input complete, 346
 - Polar coordinates, 507
 - Positions
 - display/hide, 331
 - Predrilling contour pocket - CYCLE64
 - Function - Centering, 400
 - Function - Predrilling, 400
 - Parameter - Centering, 402
 - Parameter - Predrilling, 403
 - Preview
 - Program, 591
 - Probe, 77
 - Electronic, 85
 - Program
 - Closing, 578
 - Copying, 594
 - Creating with cycle support, 237
 - Deleting, 596
 - Executing, 580
 - Highlight, 592
 - Multiple clamping, 624
 - Open, 578
 - Opening a second program, 179
 - Pasting, 594
 - Preview, 591
 - Properties, 597
 - Selecting, 592
 - Program block
 - Changing, 269
 - Configuration, 254
 - Copying and inserting, 176
 - Creating, 261
 - Current, 153
 - Delete, 176
 - linked, 254
 - Numbering, 177
 - Repeat, 266
 - Searching, 173
 - Selecting, 176
 - Program blocks, 178
 - Program control
 - Modes of operation, 167
 - Program editing, 156
 - Program header, 259
 - Important parameters, 262
 - Multiple clamping, 623
 - Program level
 - Displaying, 155
 - Program list
 - Creating, 587
 - Program Manager, 571
 - Searching directories and files, 590
 - Program runtime, 205
 - Program settings
 - Change, 270
 - Parameter, 271
 - Program views
 - ShopMill, 250
 - Programmed stop 1, 167
 - Programmed stop 2, 167
 - Programming variables, 278
 - Programs
 - Correcting, 156
 - Editing, 172
 - Managing, 571
 - Renumbering blocks, 177
 - Replacing text, 174
 - Running-in, 152
 - Searching for a program position, 173
 - Selecting, 151
 - Teach-in, 665
 - Properties
 - Directory, 597
 - Program, 597
 - Protection levels
 - Softkeys, 52
 - PRT (no axis motion), 167
- Q**
- Quantity, 549
- R**
- R parameters, 184

- Reading in
 - Setup data, 616
- Reaming - CYCLE85
 - Function, 304
 - Parameter, 305
- Rectangular pocket - POCKET3
 - Function, 337
 - Parameter - input complete, 341
- Rectangular spigot - CYCLE76
 - Function, 347
 - Parameter - input complete, 349
- Reference, 60
- Remote access
 - permit, 646
 - Setting, 644
- Remote diagnostics, 644
 - Exit, 648
 - requesting, 647
- Repeat positions
 - Function, 332
 - Parameters, 333
- Repositioning, 157
- Retract
 - Retraction, 142
- Retraction
 - Manual, 142
- RG0 (reduced rapid traverse), 167
- Rigid tapping - CYCLE84
 - Function, 311
 - Parameter, 316
- Rotation, 495

- S**
- Save
 - Setup data, 613
- SB (single blocks), 167
- SB1, 152
- SB2, 152
- SB3, 152
- Screenshots
 - Copy, 644
 - Creating, 643
 - Open, 644
- Search
 - in the Program Manager, 590
- Search mode, 165
- Search pointer, 163
- Searching
 - Logbook entry, 643
- Selecting
 - Directory, 592
 - Program, 592
- Service Planner, 707
- Setting actual values, 69
- Setting milling tool - CYCLE800
 - Function, 485
 - Parameter, 486
- Settings
 - Editor, 181
 - For automatic operation, 207
 - For manual operation, 147
 - Multi-channel view, 516
 - Teach-in, 675
 - Tool lists, 568
- Setup data
 - Backing up, 613
 - reading in, 616
- ShopMill program
 - Creating, 258
 - Cutting edge, 262
 - Feedrate, 263
 - Machine functions, 264
 - Program blocks, 261
 - Program header, 259
 - Program settings, 270
 - Program structure, 254
 - Radius compensation, 262
 - Spindle speed, 263
 - Straight line/Circle, 501
 - Tool, 262
- ShopTurn program
 - Mirroring, 497
 - Scaling, 496
- Simulation, 209
 - Alarm display, 228
 - Blank, 221
 - Changing a graphic, 224
 - Manual Machine, 663
 - Program control, 222
 - Showing and hiding the path display, 221
 - Views, 219
- Simultaneous recording, 211
 - Before machining, 217
- Single block
 - Coarse (SB1), 152
 - Fine (SB3), 152
- Sister tool number, 534
- Skip blocks, 168
- SKP (skip blocks), 167
- SLOT1 - longitudinal slot
 - Function, 355
 - Parameter - input complete, 359
- SLOT2 - circumferential slot

- Function, 360
 - Parameter - input complete, 363
 - SMS messages, 693
 - Log, 700
 - Spindle data
 - Actual value window, 41
 - Spindle speed limitation, 122
 - Status display, 35
 - Stock removal - CYCLE951
 - Function, 412
 - Parameter, 416
 - Stock removal - CYCLE952
 - Function, 455
 - Parameter - input complete, 460
 - Stock removal residual material - CYCLE952
 - Function, 461
 - Parameters, 463
 - Straight line, 503
 - Manual Machine, 655
 - Polar, 508
 - Straight line/Circle, 501
 - Submode
 - REF POINT, 63
 - Subprogram
 - Function, 491
 - Parameters, 492
 - Switching off, 59
 - Switching on, 59
 - Switching over
 - Channel, 65
 - Coordinate system, 67
 - Unit of measurement, 68
 - Swiveling
 - in JOG - Function, 137
 - in JOG - Parameter, 141
 - Manually, 137
 - Swiveling - CYCLE800
 - Function, 475
 - Parameters, 482
 - Symbol tables, 727
 - Synchronized actions
 - Displaying status, 196
- T**
- Tapered thread - CYCLE99
 - Parameter - input complete, 437
 - Tapping with compensating chuck - CYCLE840
 - Function, 311
 - Parameter, 316
 - Teach-in, 665
 - Changing blocks, 673
 - Circle intermediate position CIP, 671
 - Continuous-path mode, 668
 - Deleting blocks, 675
 - General sequence, 665
 - Inserting a position, 666
 - Inserting blocks, 669
 - Motion type, 667
 - Parameter, 667
 - Rapid traverse G0, 670
 - Selecting a block, 674
 - Settings, 675
 - Traversing block G1, 670
 - Templates
 - Creating, 589
 - Storage locations, 589
 - Thread chain - CYCLE98
 - Function, 438
 - Parameter - input simple, 440
 - Thread milling - CYCLE70
 - Function, 373
 - Parameter, 376
 - Thread turning - CYCLE99
 - Function - Face thread, 429
 - Function - Longitudinal thread, 429
 - Function - Tapered thread, 429
 - Tip angle, 534
 - Tool
 - Automatic measurement, 75
 - Change type, 567
 - Create, 538
 - Deleting, 541
 - Details, 564
 - Dimensioning, 527
 - Loading, 542
 - Manual measurement, 71
 - Measuring, 71
 - Multiple edges, 540
 - Reactivating, 551
 - Relocating, 555
 - Unloading, 542
 - Tool data
 - Actual value window, 40
 - Backing up, 613
 - reading in, 616
 - Tool details
 - All parameters, 566
 - Tool life, 549
 - Tool list, 534
 - Tool lists
 - Settings, 568
 - Tool management, 523
 - List filtering, 561

- Sorting lists, 560
- Tool parameters, 527
- Tool probe, 77
- Tool types, 525
- Tool wear, 548
- Tool wear list
 - Open, 548
- Tools
 - Graphic display, 558
- Touch Panel
 - Calibrating, 684
- Transformed view, 568

U

- Undercut - CYCLE940
 - Function - DIN thread, 426
 - Function - Form E, 422
 - Function - Form F, 422
 - Function - Thread, 426
 - Parameter - DIN thread, 427
 - Parameter - Form E, 424
 - Parameter - Form F, 425
 - Parameter - Thread, 428
- Unit of measurement
 - Switching over, 68
- User agreement, 61
- User data, 183
- User variables
 - Activating, 189
 - Channel GUD, 186
 - Defining, 189
 - Global GUD, 189
 - Local LUD, 187
 - Program PUD, 188
 - R parameters, 184
 - Searching, 189

V

- Variable screen forms, 636
- Virtual keyboard, 682

W

- Wear, 549
- Work offset
 - Manual Machine, 651
- Work offsets
 - Calling, 266
- Work plan

- ShopMill, 250
- Working area limitation
 - Defining, 121
- Workpiece
 - Creating, 582
- Workpiece counter, 205
- Workpiece zero
 - Aligning the edge, 89
 - Aligning the plane, 108
 - Automatic measurement, 78
 - Changing the user interface, 110
 - Corrections after measurement, 111
 - Manual Machine, 650
 - Manual measurement, 78
 - Measuring a circular spigot, 101
 - Measuring a hole, 95
 - Measuring a rectangular pocket, 95
 - Measuring a rectangular spigot, 101
 - Measuring a right-angled corner, 91
 - Measuring any corner, 91
 - Measuring the distance between two edges, 89

Z

- Zero offsets
 - Active ZO, 114
 - Delete, 119
 - Displaying details, 118
 - Overview, 115
 - Settable ZO, 117
 - Setting, 69
- Zero point settings
 - Backing up, 613
 - reading in, 616