

OWNER'S MANUAL

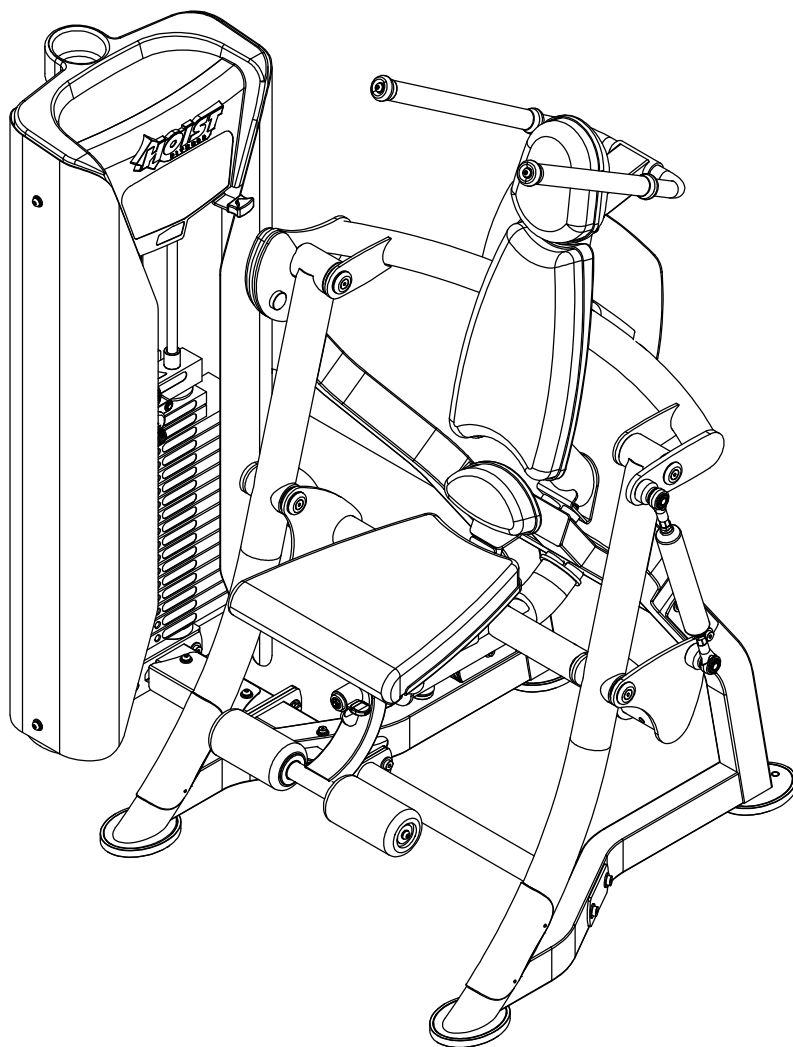

RS-2601 ROC-IT SELECTORIZED AB



****WARNING!****

TO PREVENT POSSIBLE TIPPING, BOLT THIS UNIT TO THE EXERCISE FLOOR USING MINIMUM 4 - 1/2" LONG BOLTS. FAILURE TO DO SO MAY RESULT IN SERIOUS INJURY OR DEATH.

Note: Both Serial Number and Model Number are Required when Ordering Parts

RECORD SERIAL NUMBER HERE

MACHINE CODE

Customer Service

(800) 548-5438

(858) 578-7676

Fax

(858) 578-9558



www.facebook.com/hoistfitness

OWNER'S MANUAL

CONTENTS

INSTRUCTIONS	02
FRAME ASSEMBLY	04
PRE-ASSEMBLY.....	23
DECAL PLACEMENT.....	25
DECAL REFERENCE.....	27
PART LIST.....	29
ABBREVIATIONS.....	32
BOLT SIZING CHART.....	33
WASHER SIZING CHART.....	34
MAINTENANCE SCHEDULE.....	36
GENERAL MAINTENANCE INFORMATION.....	37
WEIGHT TRAINING TIPS.....	38
EXERCISE LOG.....	39
LIMITED WARRANTY.....	40

OWNER'S MANUAL

INSTRUCTIONS

Before beginning assembly please take the time to read instructions thoroughly. Please use the various lists in this manual to make sure that all parts have been included in your shipment. When ordering, use part number and description from the lists. Use only HOIST replacement parts when servicing. Failure to do so will void your warranty and could result in personal injury.

HOIST equipment is designed to provide the smoothest, most effective exercise motion possible. After assembly, you should check all functions to ensure correct operation. If you experience problems, first recheck the assembly instructions to locate any possible errors made during assembly. If you are unable to correct the problem, call your authorized HOIST dealer. Be sure to have your serial number and this manual when calling. When all parts have been accounted for, continue on.

TOOLS REQUIRED

Ratchet Wrench

1/2", 9/16" and 3/4" Sockets

Adjustable Wrench

Rubber Mallet

Tape Measure

Level

SAE Hex Key Wrench Set

Two People

OWNER'S MANUAL

THIS PAGE WAS INTENTIONALLY LEFT BLANK

OWNER'S MANUAL

FRAME ASSEMBLY

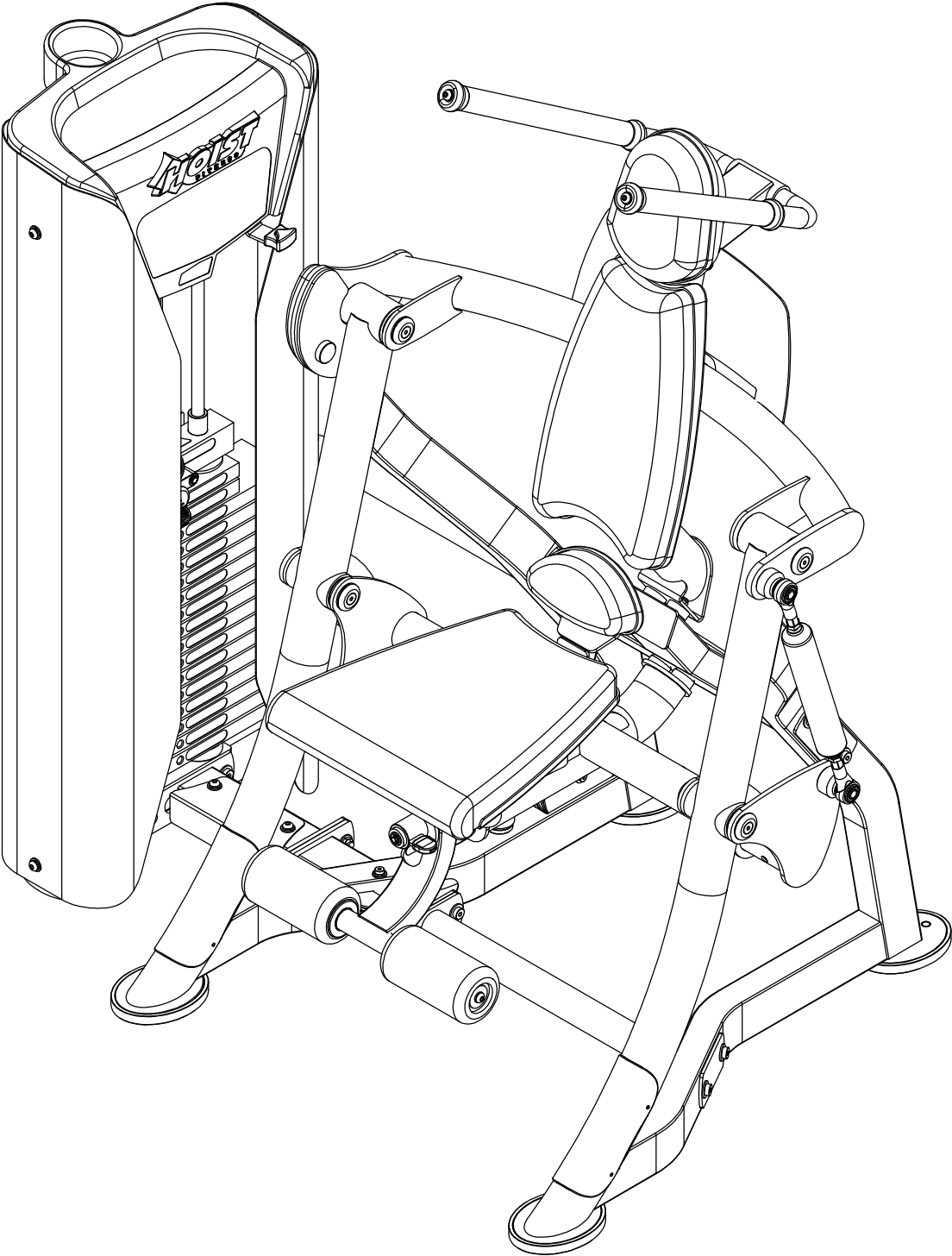

OWNER'S MANUAL

FRAME ASSEMBLY

REFER TO RS-CAGE-NG MANUAL BEFORE BEGINNING THIS STEP

NOTE:

- HAND TIGHTEN HARDWARE.
- SOME PARTS MAY HAVE BEEN REMOVED FOR CLARITY.

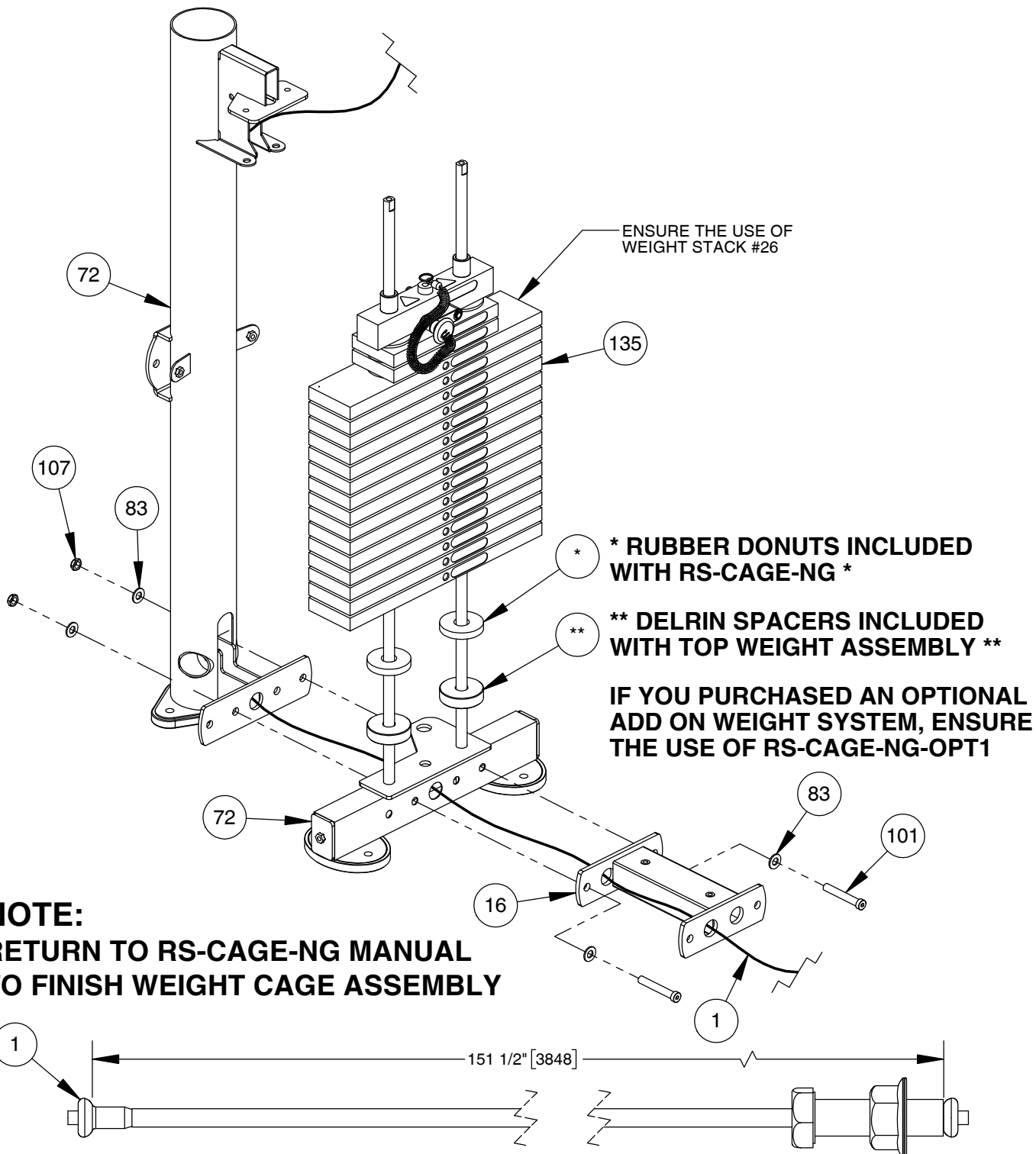

OWNER'S MANUAL

FRAME ASSEMBLY

NOTE:
- HAND TIGHTEN HARDWARE.
- SOME PARTS MAY HAVE BEEN
REMOVED FOR CLARITY.

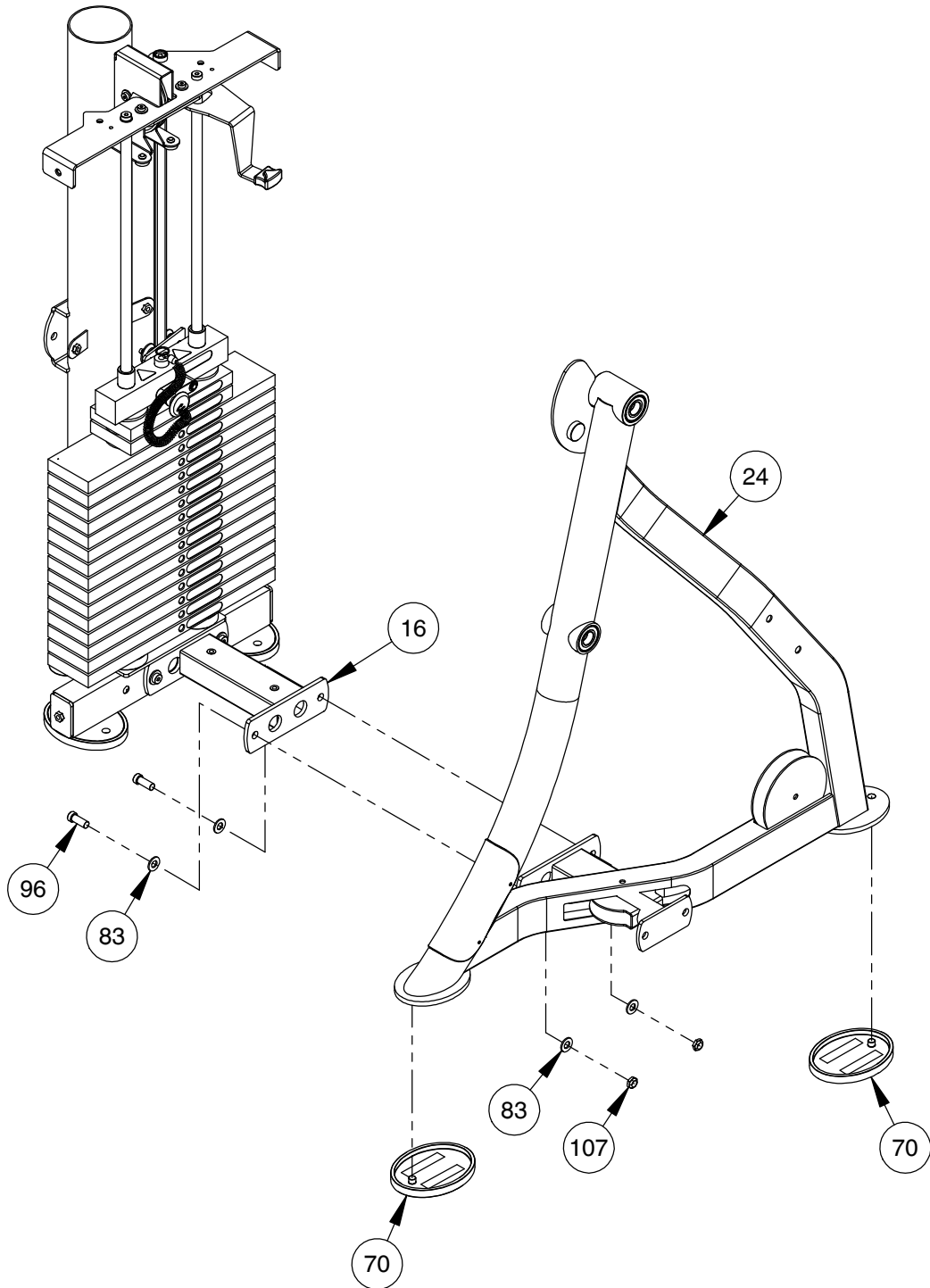

OWNER'S MANUAL

FRAME ASSEMBLY

NOTE:
- HAND TIGHTEN HARDWARE.
- SOME PARTS MAY HAVE BEEN
REMOVED FOR CLARITY.

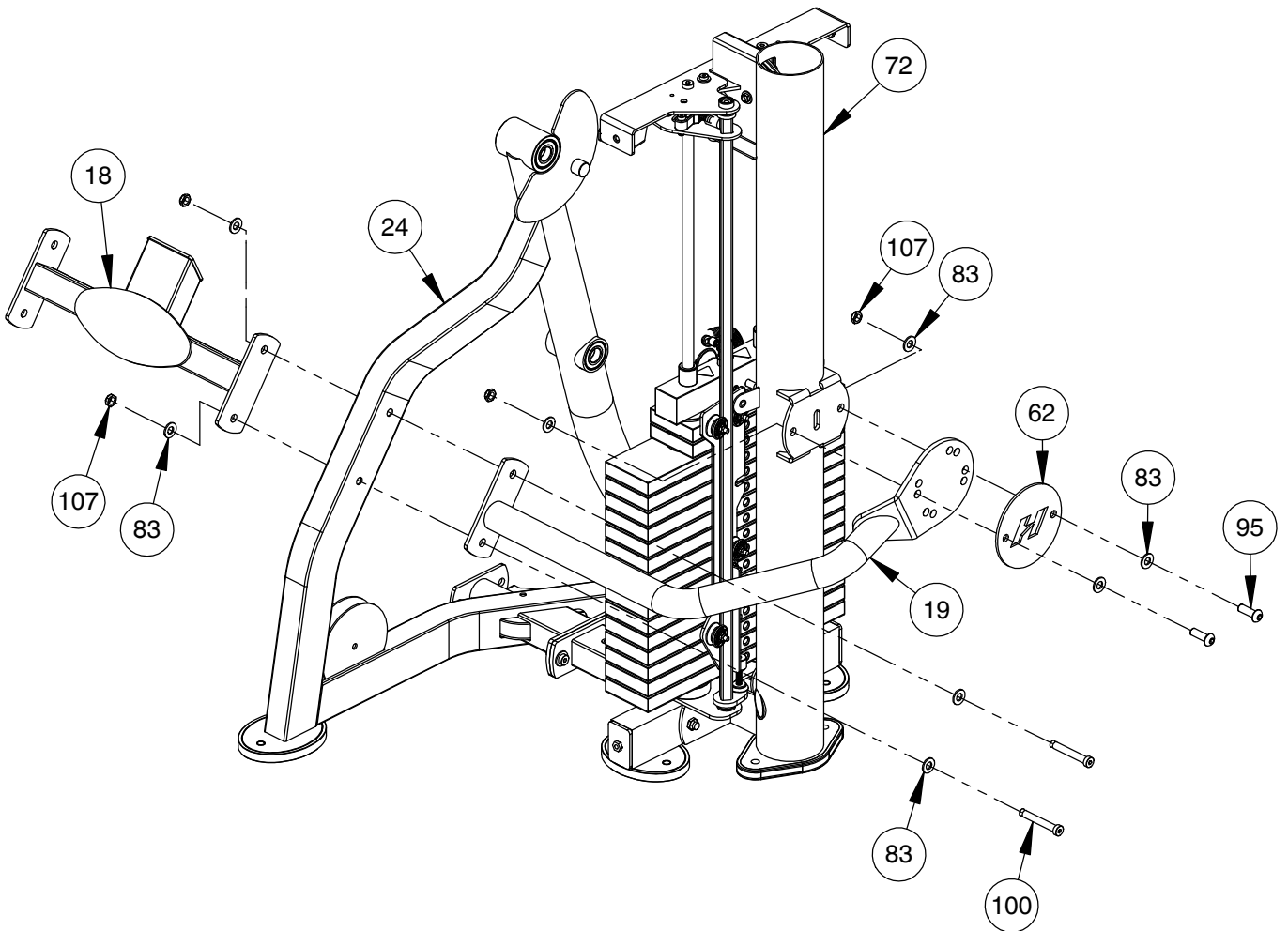

OWNER'S MANUAL

FRAME ASSEMBLY

NOTE:
- HAND TIGHTEN HARDWARE.
- SOME PARTS MAY HAVE BEEN
REMOVED FOR CLARITY.

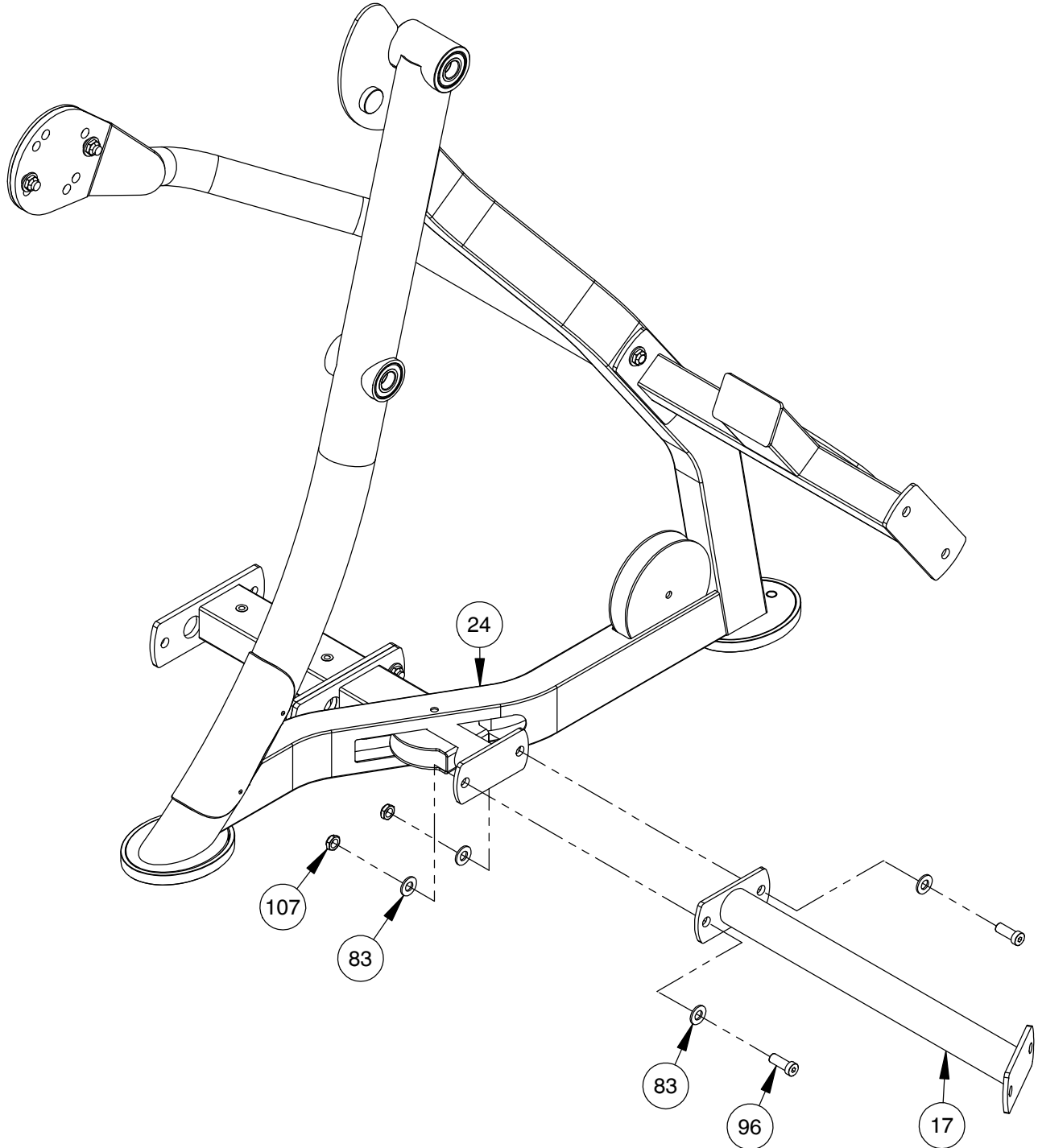

OWNER'S MANUAL

FRAME ASSEMBLY

NOTE:
- HAND TIGHTEN HARDWARE.
- SOME PARTS MAY HAVE BEEN
REMOVED FOR CLARITY.

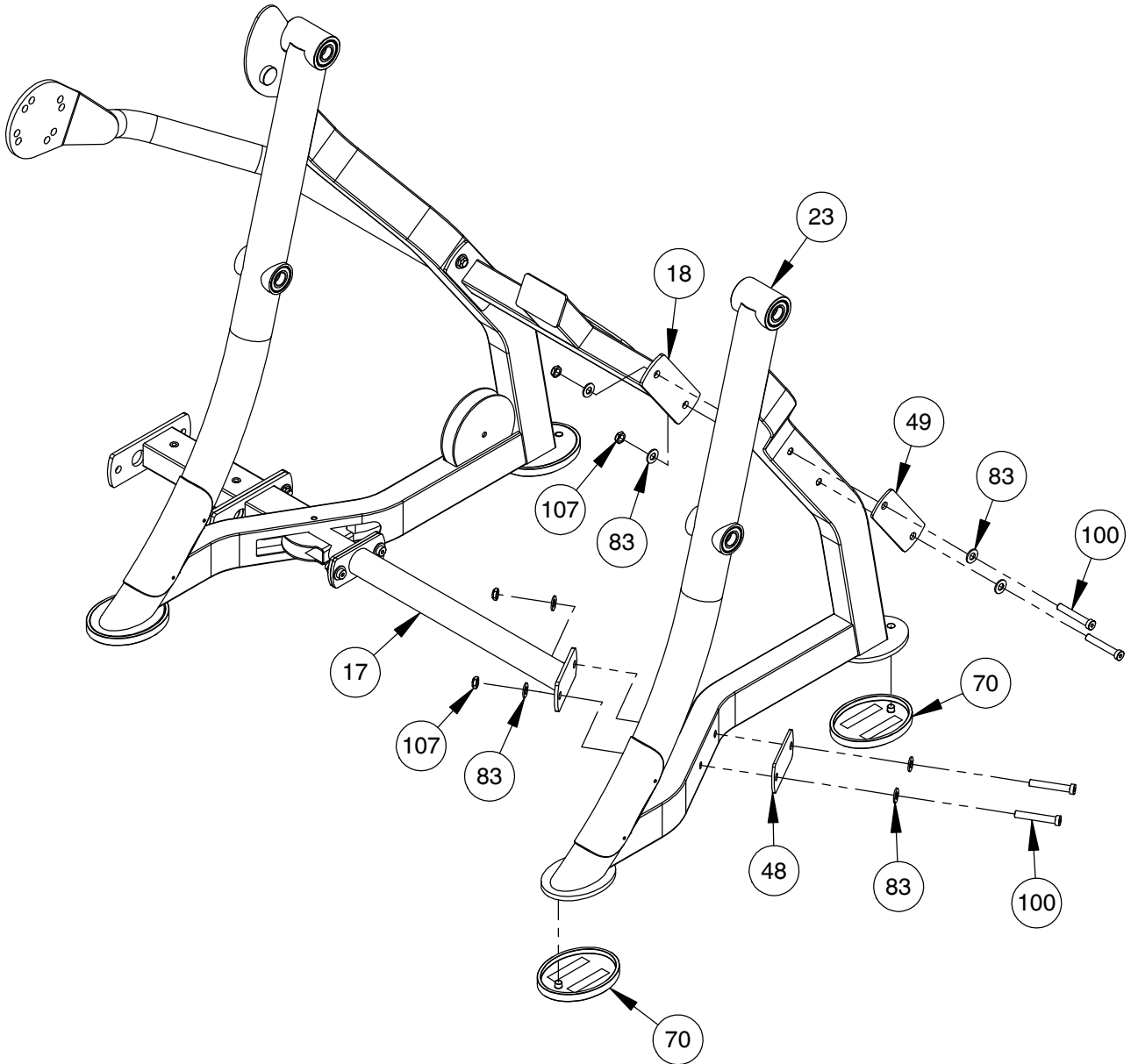

OWNER'S MANUAL

FRAME ASSEMBLY

NOTE:
REPEAT PROCEDURE
FOR ALL OTHER
INSTANCES (134).

NOTE:
- HAND TIGHTEN HARDWARE.
- SOME PARTS MAY HAVE BEEN
REMOVED FOR CLARITY.

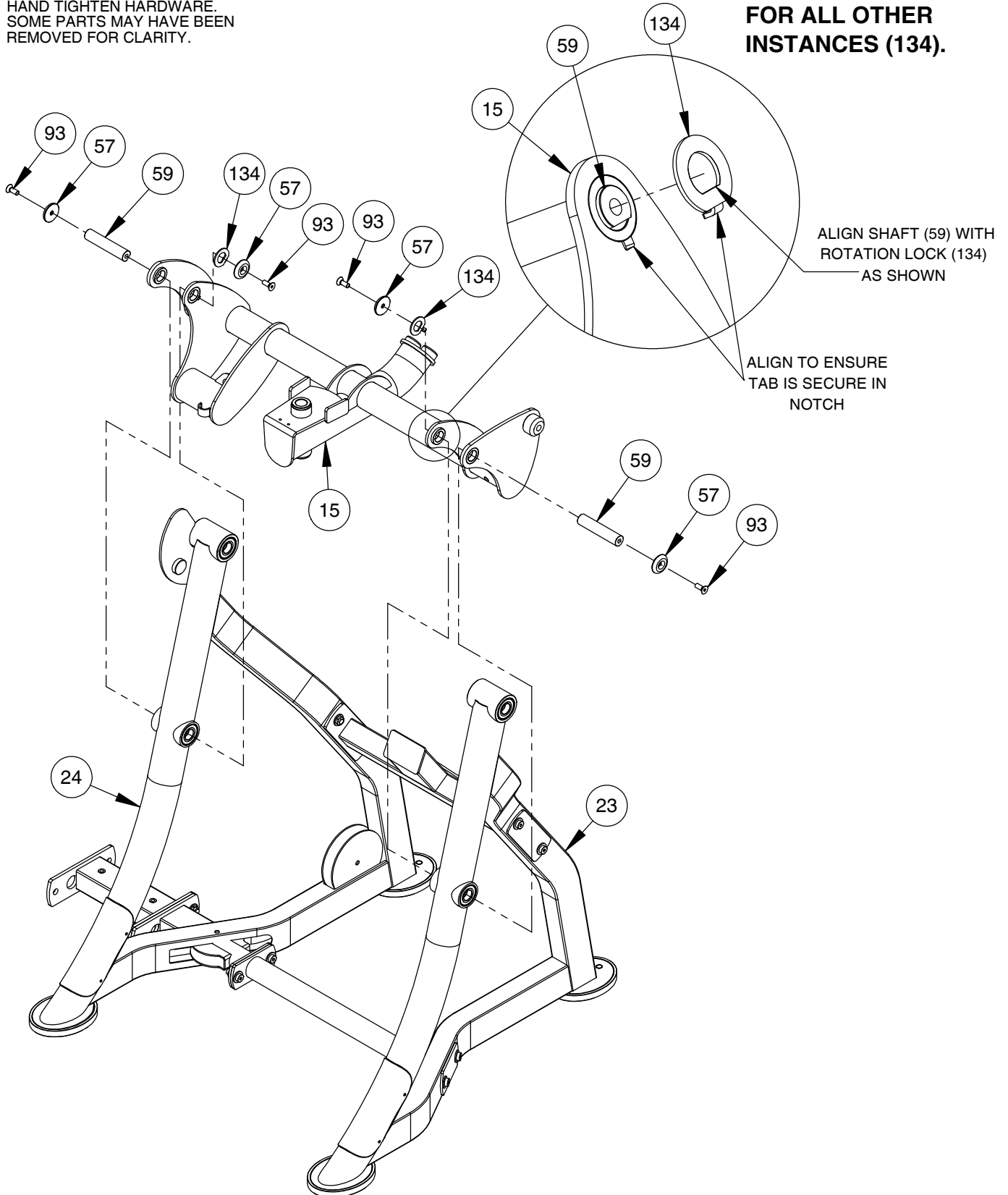

OWNER'S MANUAL

FRAME ASSEMBLY

DETAIL VIEW
CABLE QUICK RELEASE ASSEMBLY

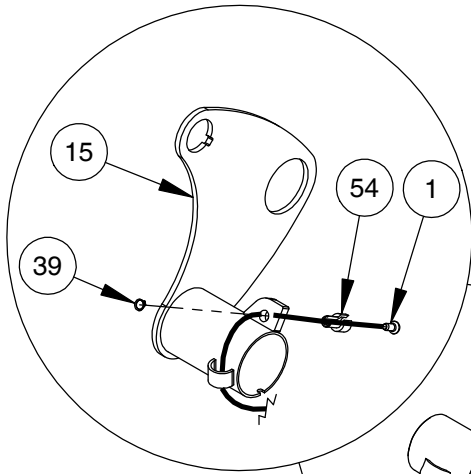

- NOTE:
- WRENCH TIGHTEN HARDWARE.
 - INSTALL CABLE AND PULLEYS AT THE SAME TIME.
 - SOME PARTS MAY HAVE BEEN REMOVED FOR CLARITY.

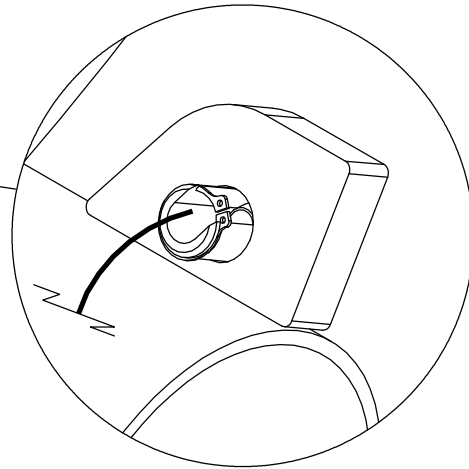

DETAIL VIEW
COMPLETED CABLE QUICK RELEASE

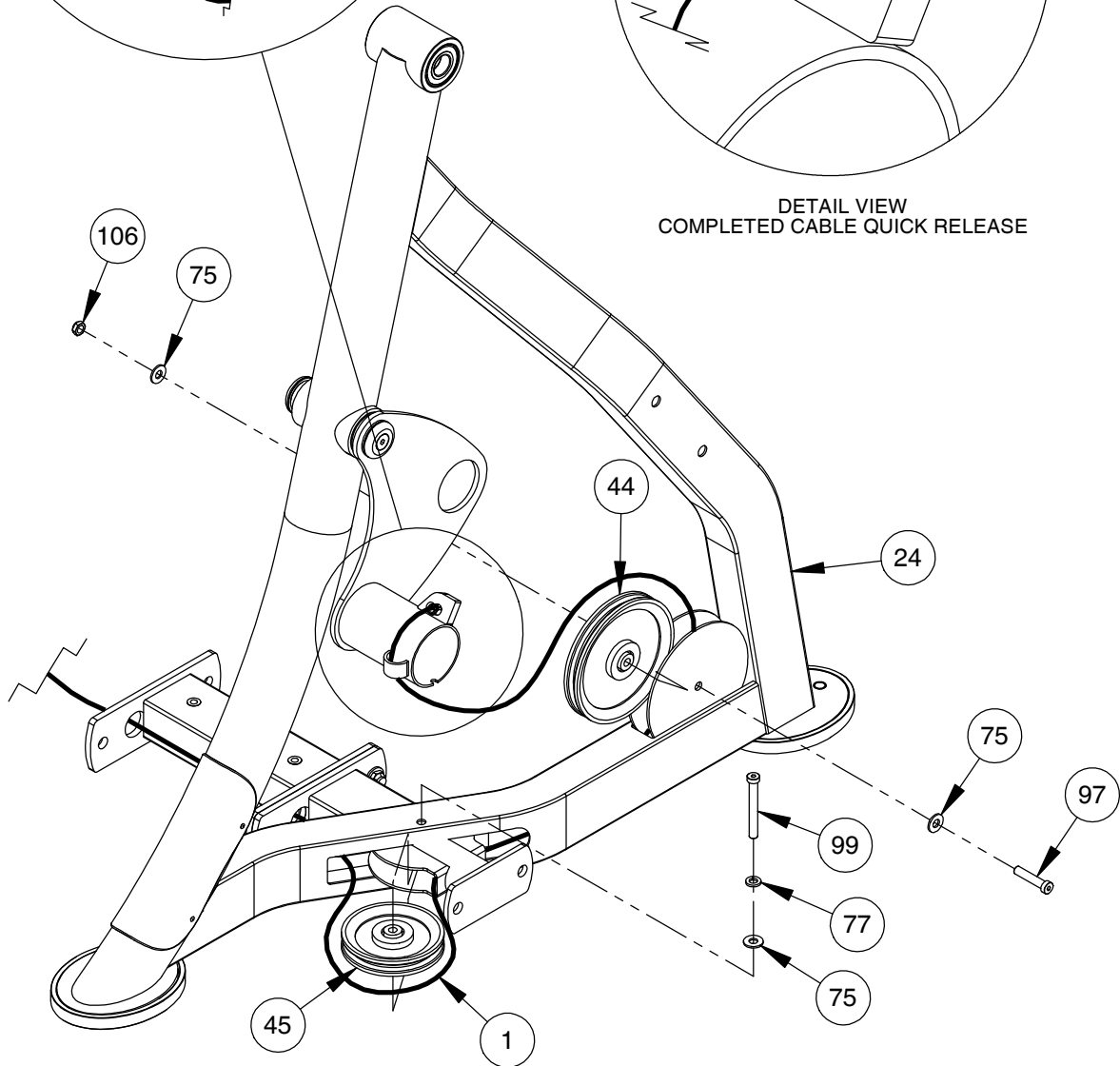

OWNER'S MANUAL

FRAME ASSEMBLY

NOTE:
- WRENCH TIGHTEN HARDWARE.
- SOME PARTS MAY HAVE BEEN
REMOVED FOR CLARITY.

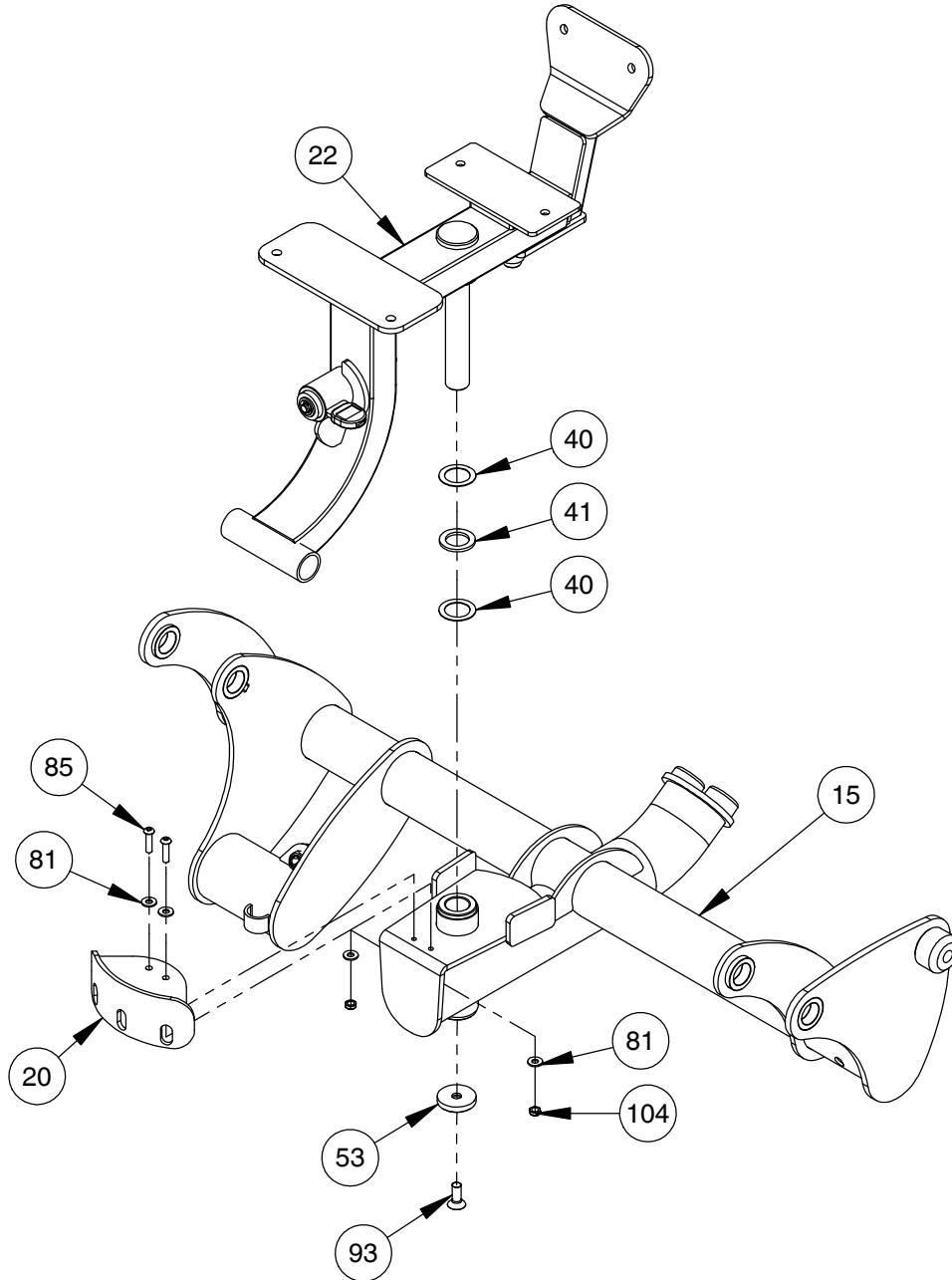

OWNER'S MANUAL

FRAME ASSEMBLY

NOTE:
- WRENCH TIGHTEN HARDWARE.
- SOME PARTS MAY HAVE BEEN
REMOVED FOR CLARITY.

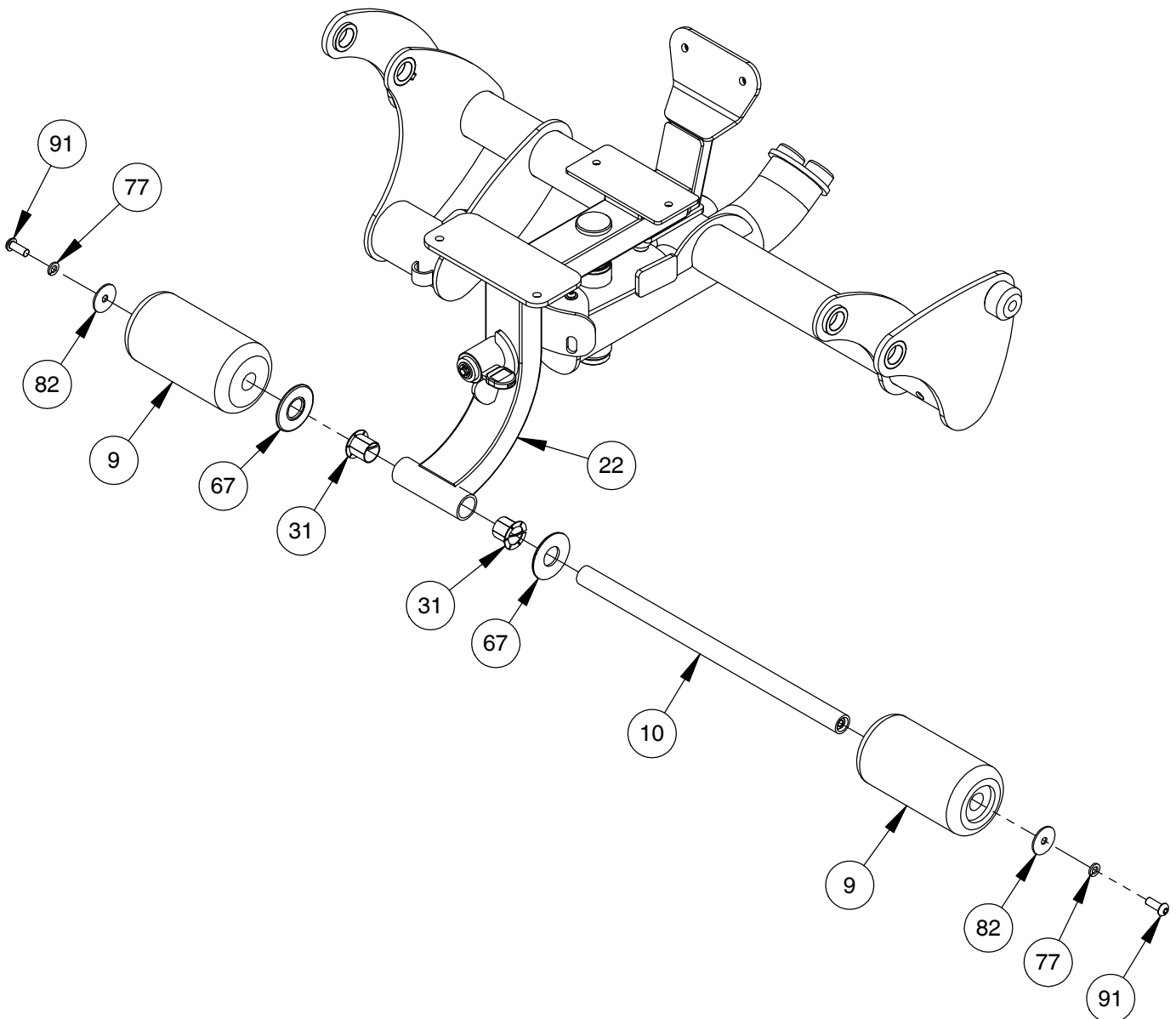

OWNER'S MANUAL

FRAME ASSEMBLY

STEP 1

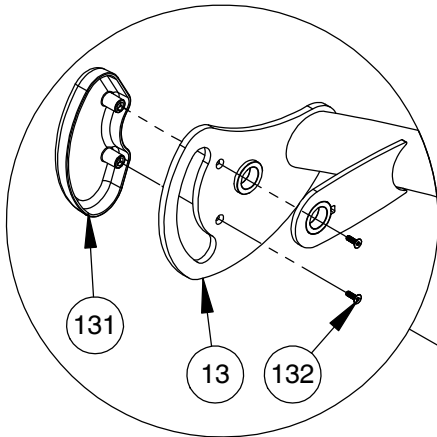

DETAIL VIEW
COVER (131) ASSEMBLY

STEP 2

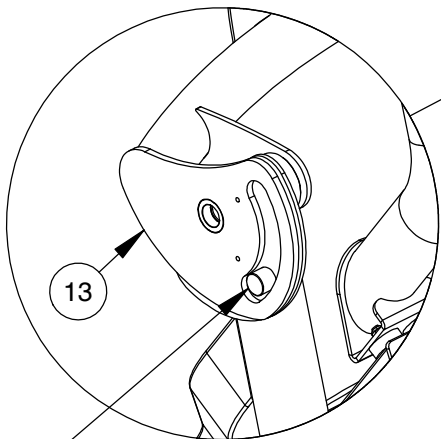

HOLD (13) UPSIDE DOWN
AND ROTATE TO INSERT
SLOT INTO STOP.

STEP 3

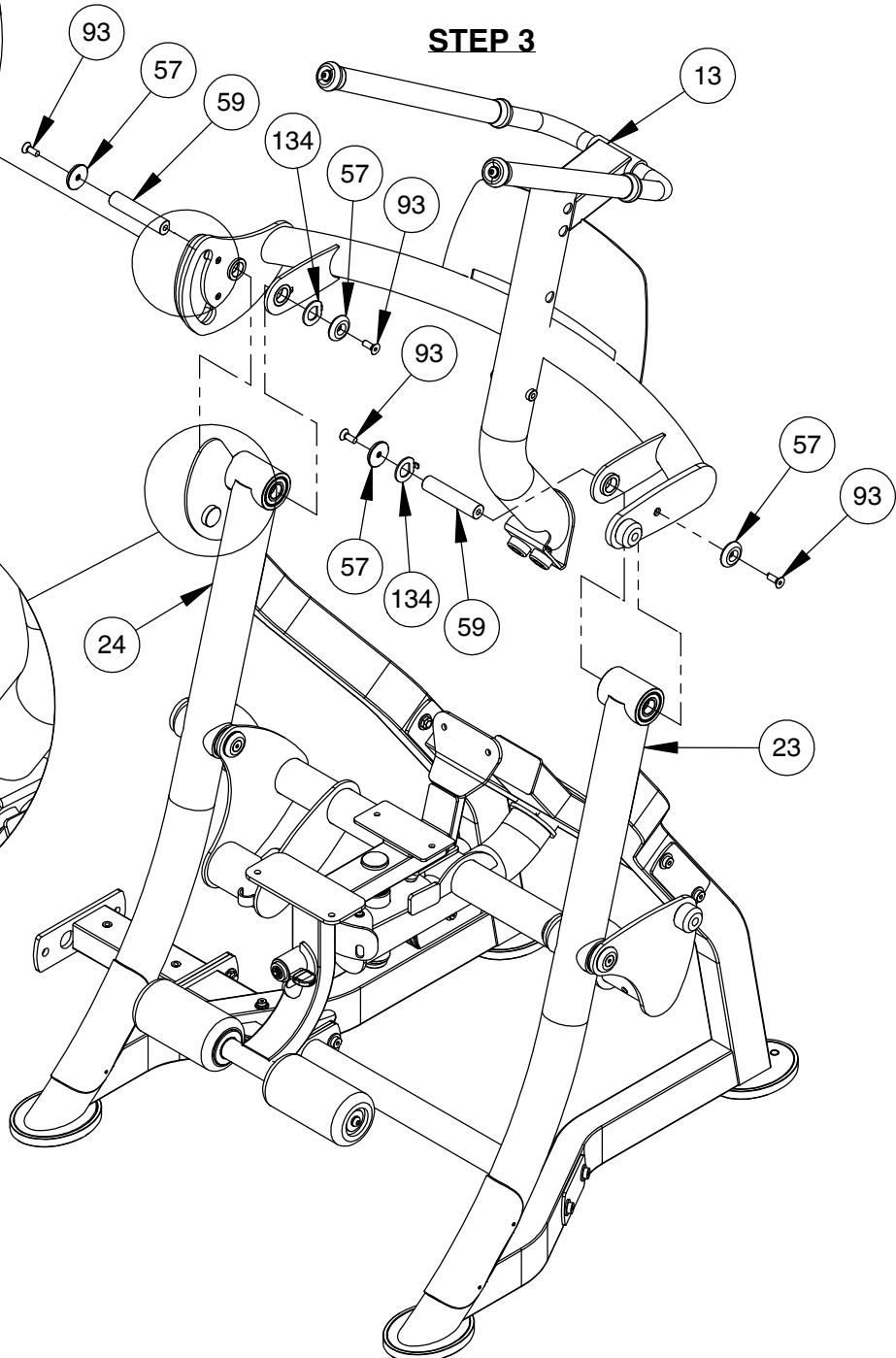

NOTE:
- WRENCH TIGHTEN HARDWARE.
- SOME PARTS MAY HAVE BEEN
REMOVED FOR CLARITY.

OWNER'S MANUAL

FRAME ASSEMBLY

- NOTE:
- WRENCH TIGHTEN HARDWARE.
 - WRENCH TIGHTEN HARDWARE (108) THEN LOOSEN NUT JUST ENOUGH FOR (11,12) TO PIVOT FREELY.
 - SOME PARTS MAY HAVE BEEN REMOVED FOR CLARITY.

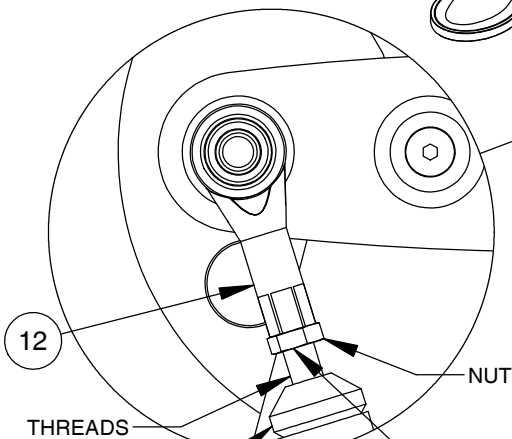
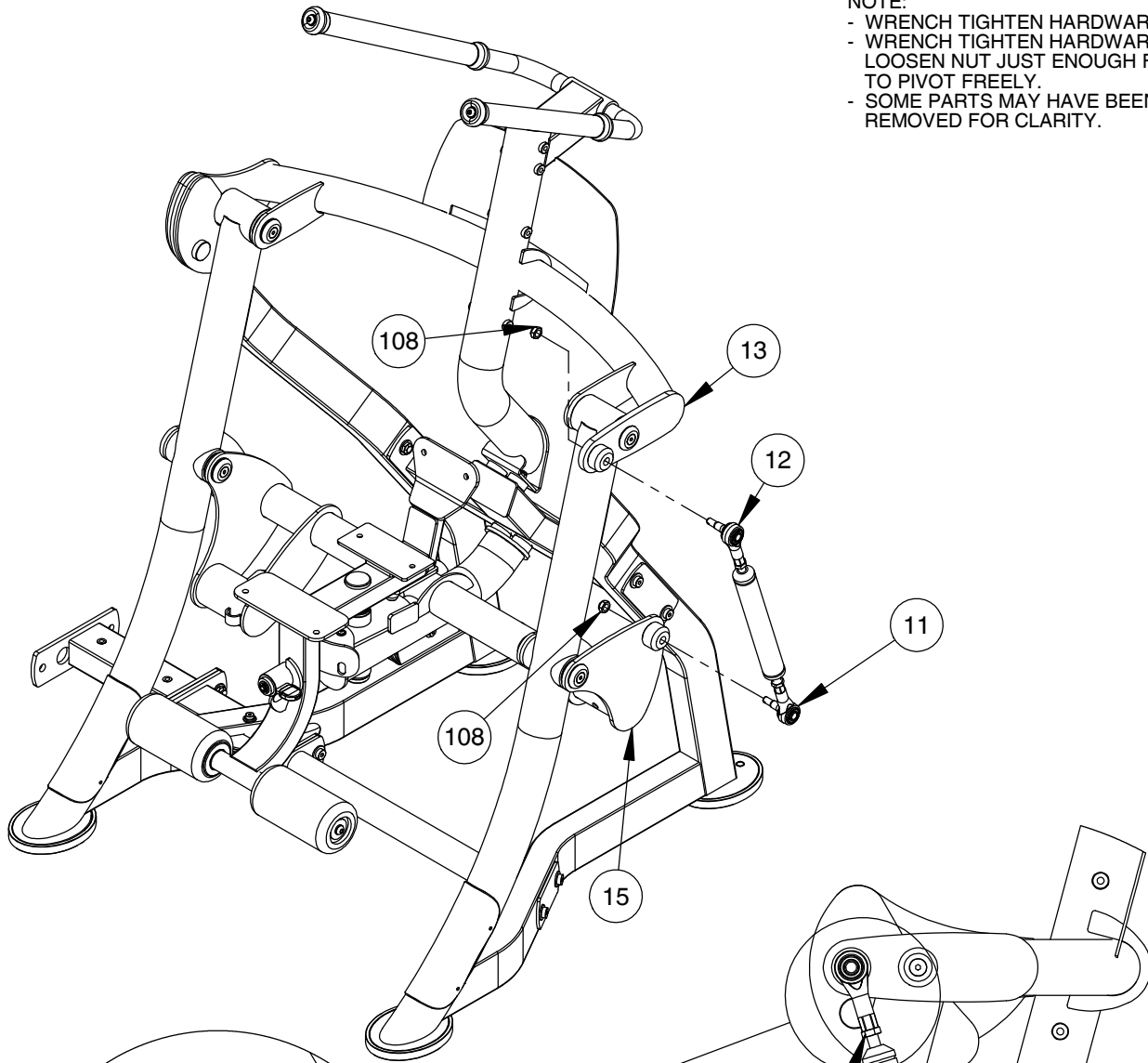

STEP 1
TIGHTEN/LOOSEN JAM NUTS
SO THAT RUBBER BUMPERS
MAKE CONTACT WITH
STOPPER.

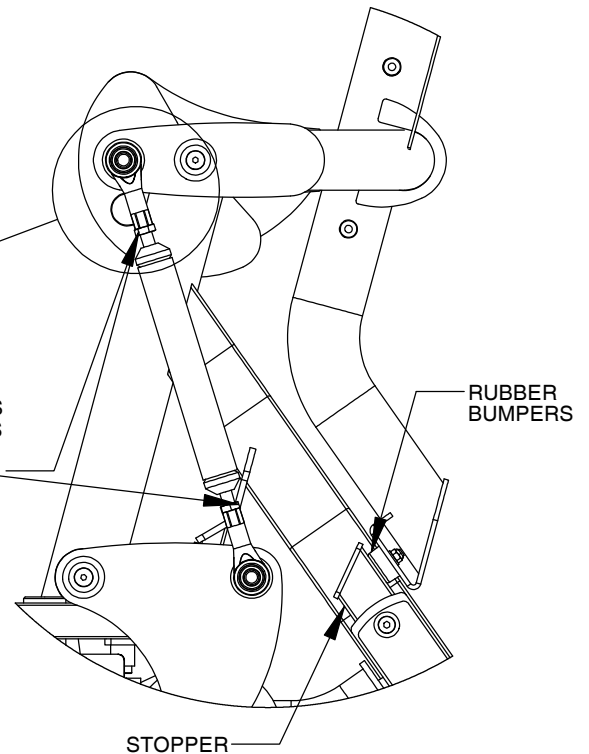

STEP 2
WRENCH TIGHTEN NUT SO THAT IT
RESTS AGAINST THE LEFT HANDED TIE ROD END (12).
REPEAT FOR THE RIGHT HANDED TIE ROD END (11).

OWNER'S MANUAL

FRAME ASSEMBLY

- NOTE:
- WRENCH TIGHTEN HARDWARE.
 - WRENCH TIGHTEN ALL PREVIOUSLY HAND TIGHTENED HARDWARE.
 - SOME PARTS MAY HAVE BEEN REMOVED FOR CLARITY.

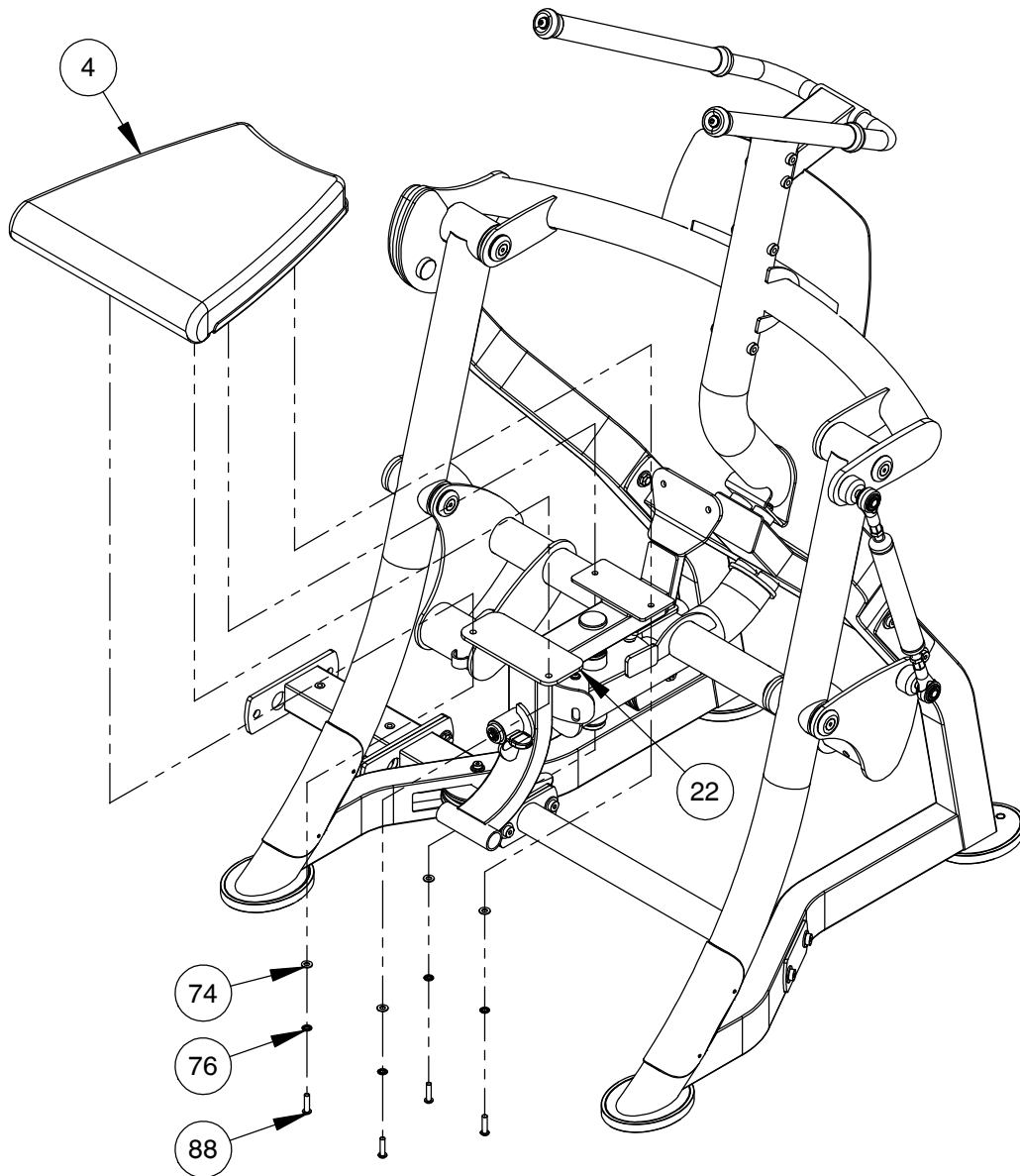

OWNER'S MANUAL

FRAME ASSEMBLY

NOTE:
- WRENCH TIGHTEN HARDWARE.
- SOME PARTS MAY HAVE BEEN
REMOVED FOR CLARITY.

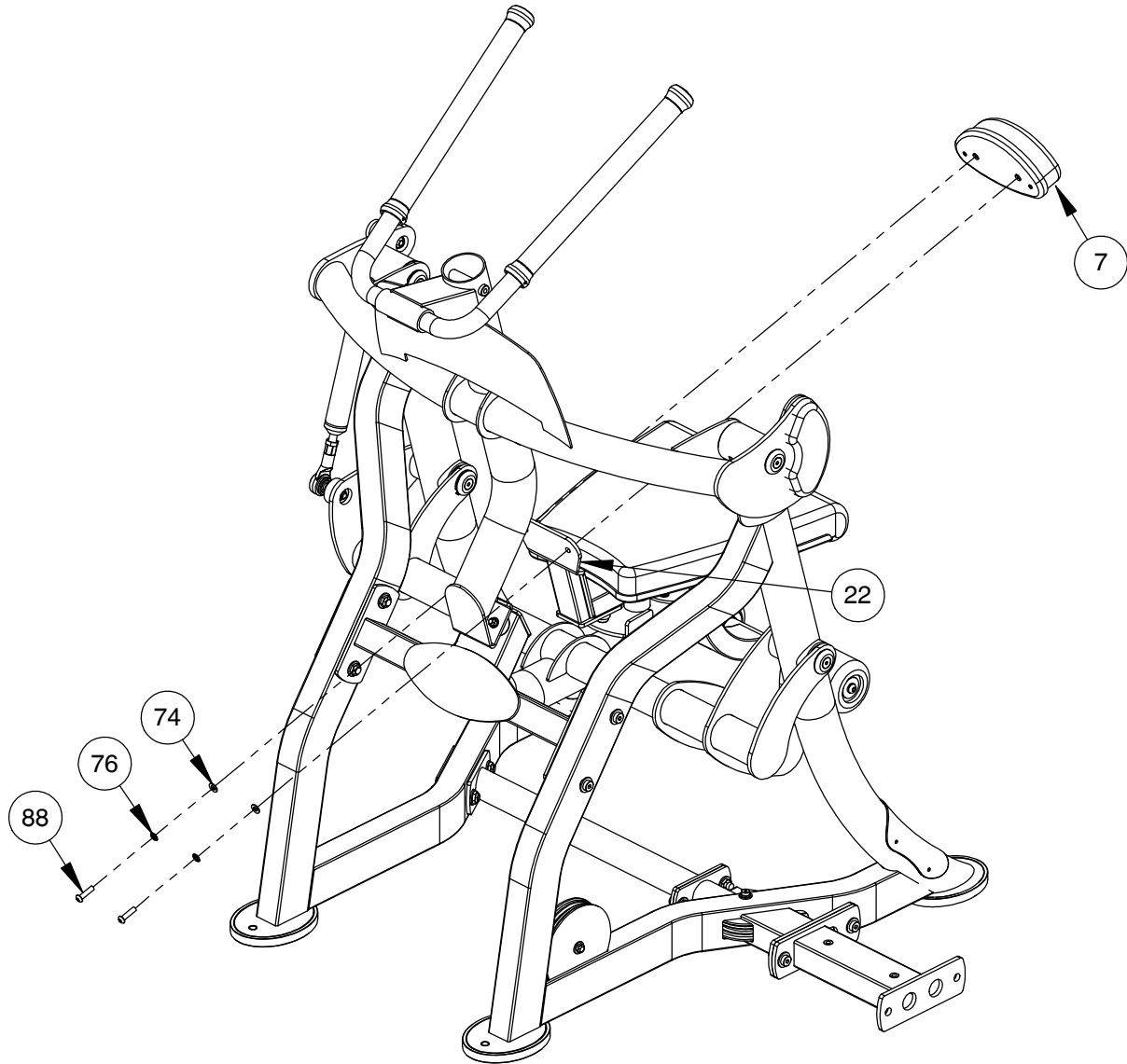

OWNER'S MANUAL

FRAME ASSEMBLY

NOTE:
- WRENCH TIGHTEN HARDWARE.
- SOME PARTS MAY HAVE BEEN
REMOVED FOR CLARITY.

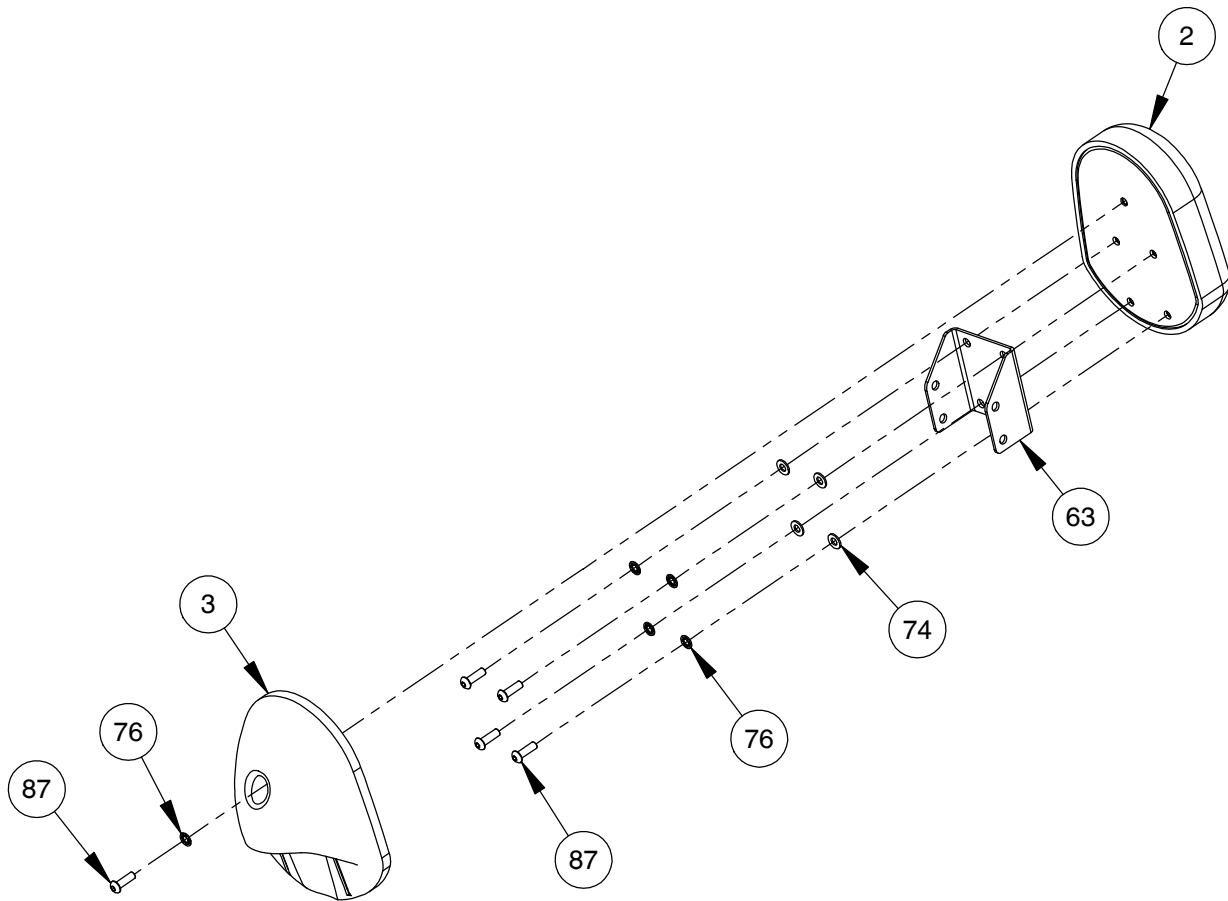

OWNER'S MANUAL

FRAME ASSEMBLY

NOTE:
- WRENCH TIGHTEN HARDWARE.
- SOME PARTS MAY HAVE BEEN
REMOVED FOR CLARITY.

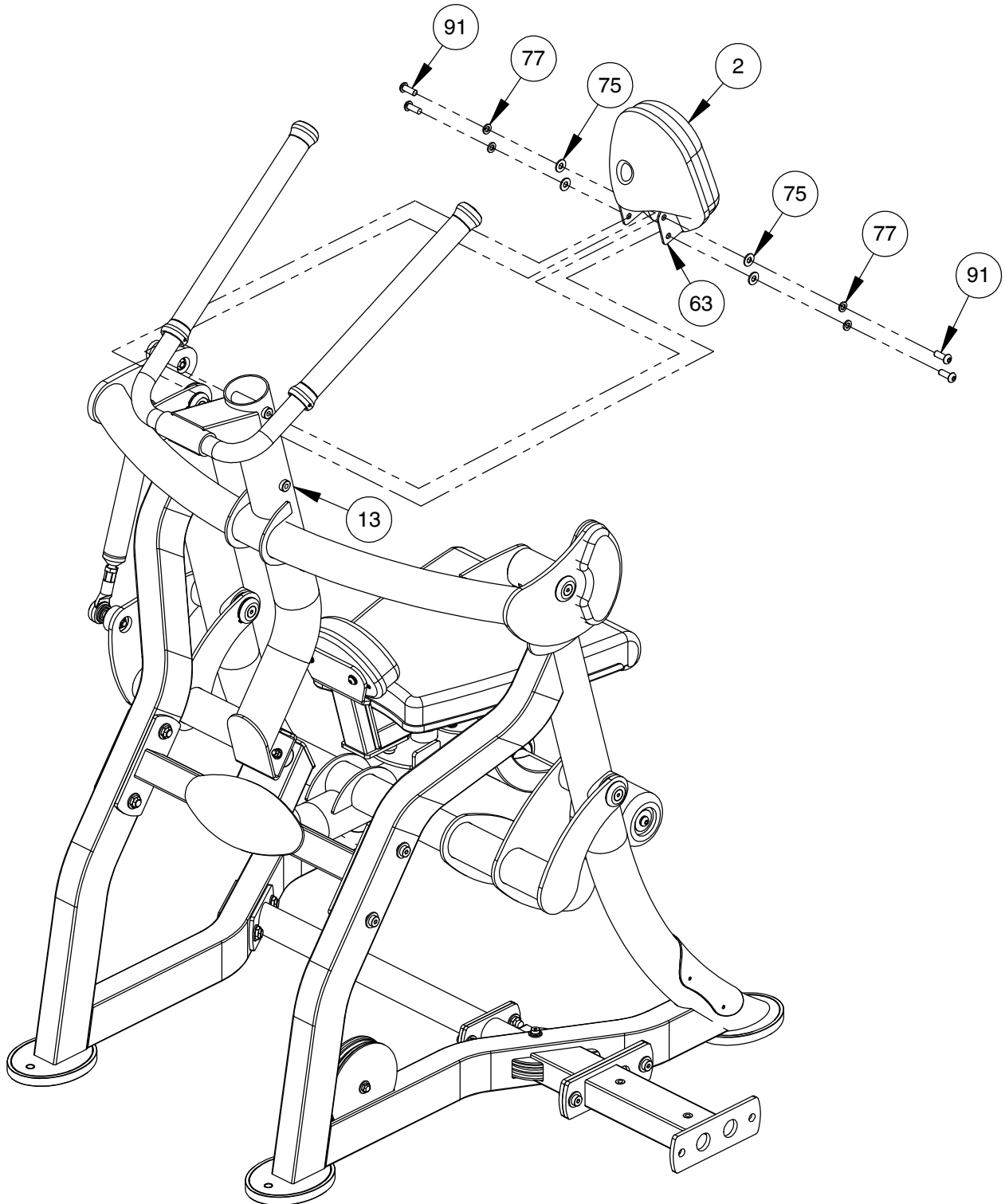

OWNER'S MANUAL

FRAME ASSEMBLY

NOTE:
- WRENCH TIGHTEN HARDWARE.
- SOME PARTS MAY HAVE BEEN
REMOVED FOR CLARITY.

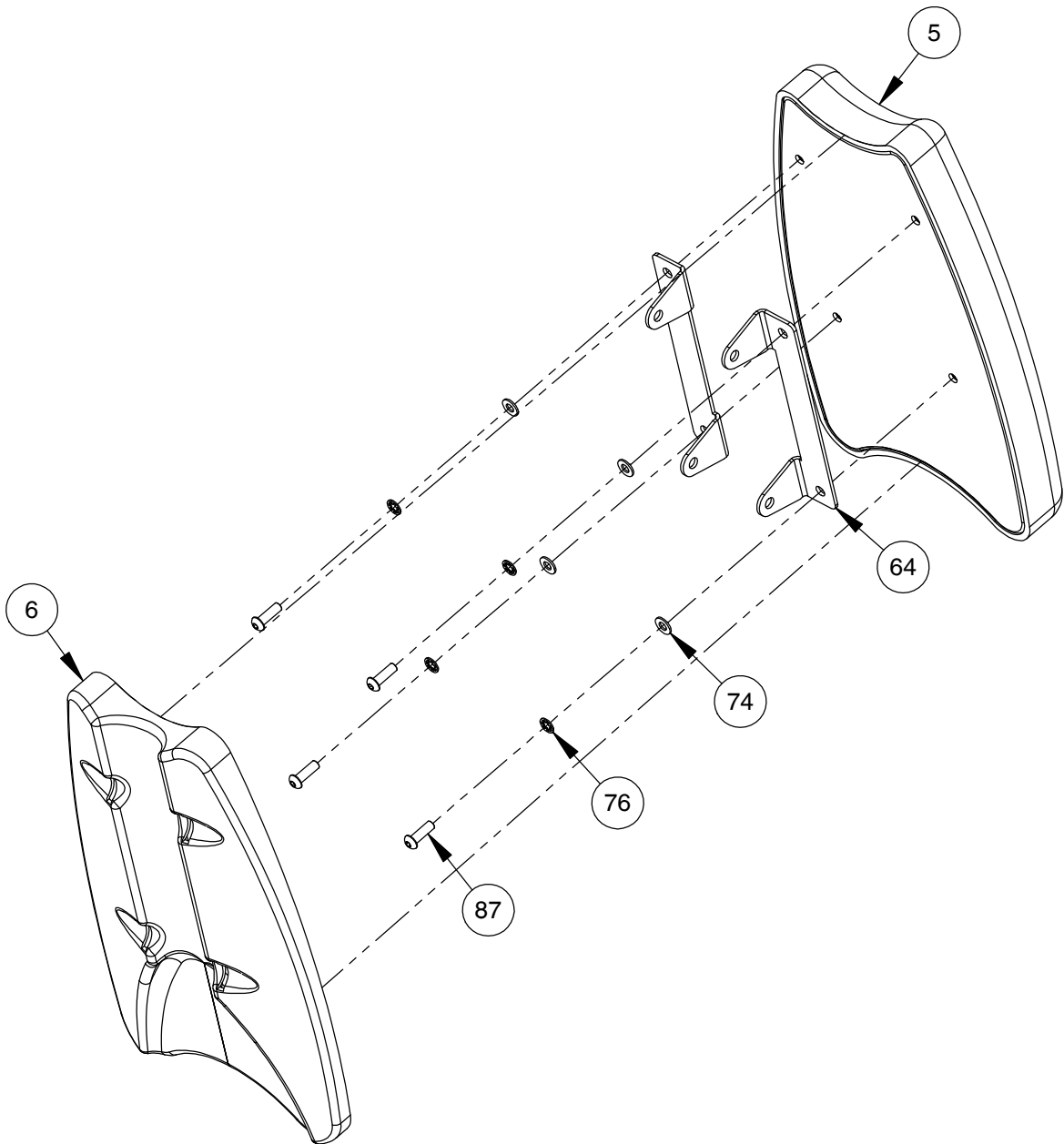

OWNER'S MANUAL

FRAME ASSEMBLY

- NOTE:
- WRENCH TIGHTEN HARDWARE.
 - REPEAT ASSEMBLY FOR OPPOSITE SIDE (75, 77, 91).
 - SOME PARTS MAY HAVE BEEN REMOVED FOR CLARITY.

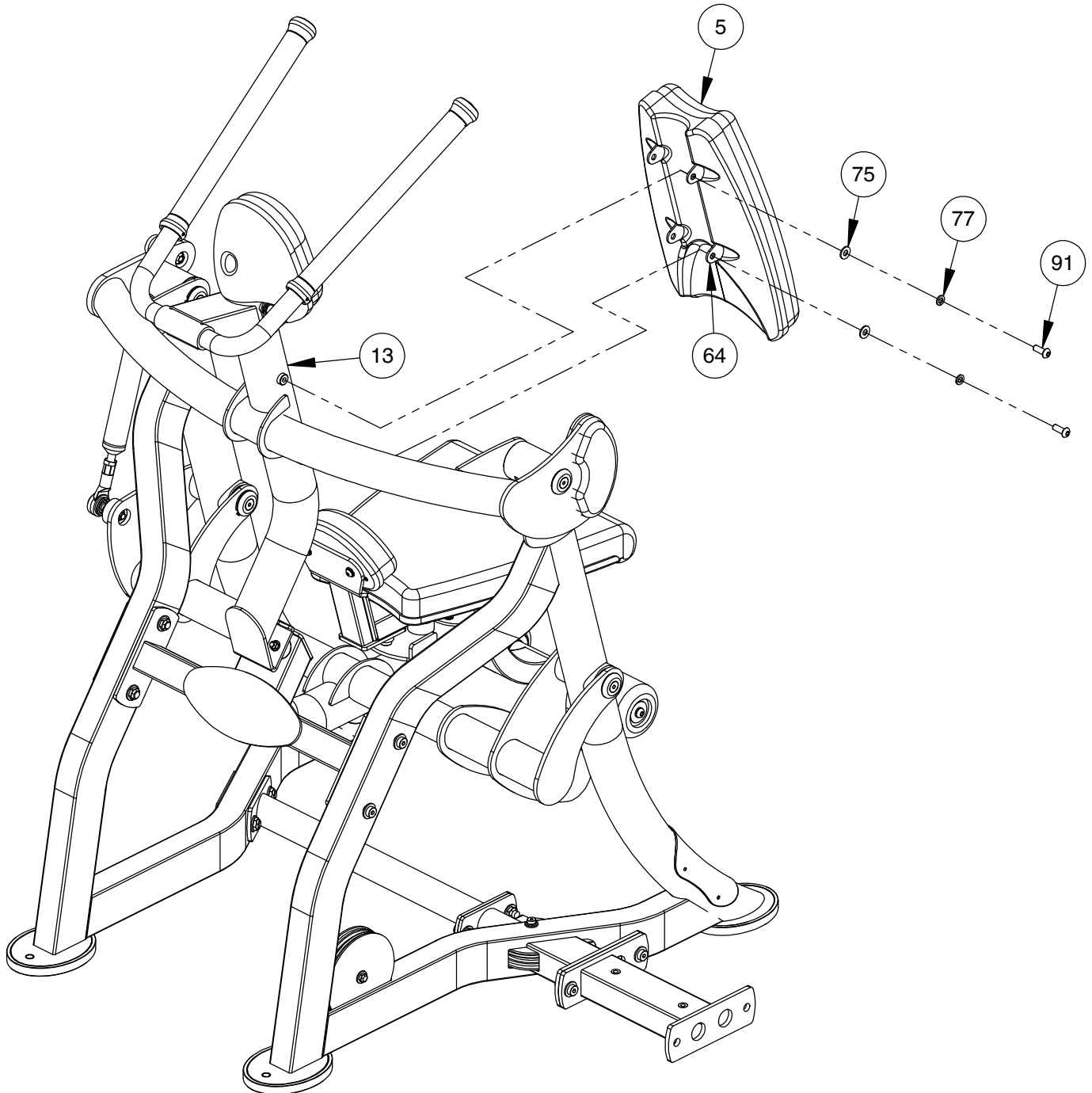

OWNER'S MANUAL

FRAME ASSEMBLY

NOTE:
- WRENCH TIGHTEN HARDWARE.
- SOME PARTS MAY HAVE BEEN REMOVED FOR CLARITY.

STOP

WHEN FINISHED WITH THIS STEP
PLEASE SEE RS-CAGE-NG MANUAL
FOR FINAL ASSEMBLY.

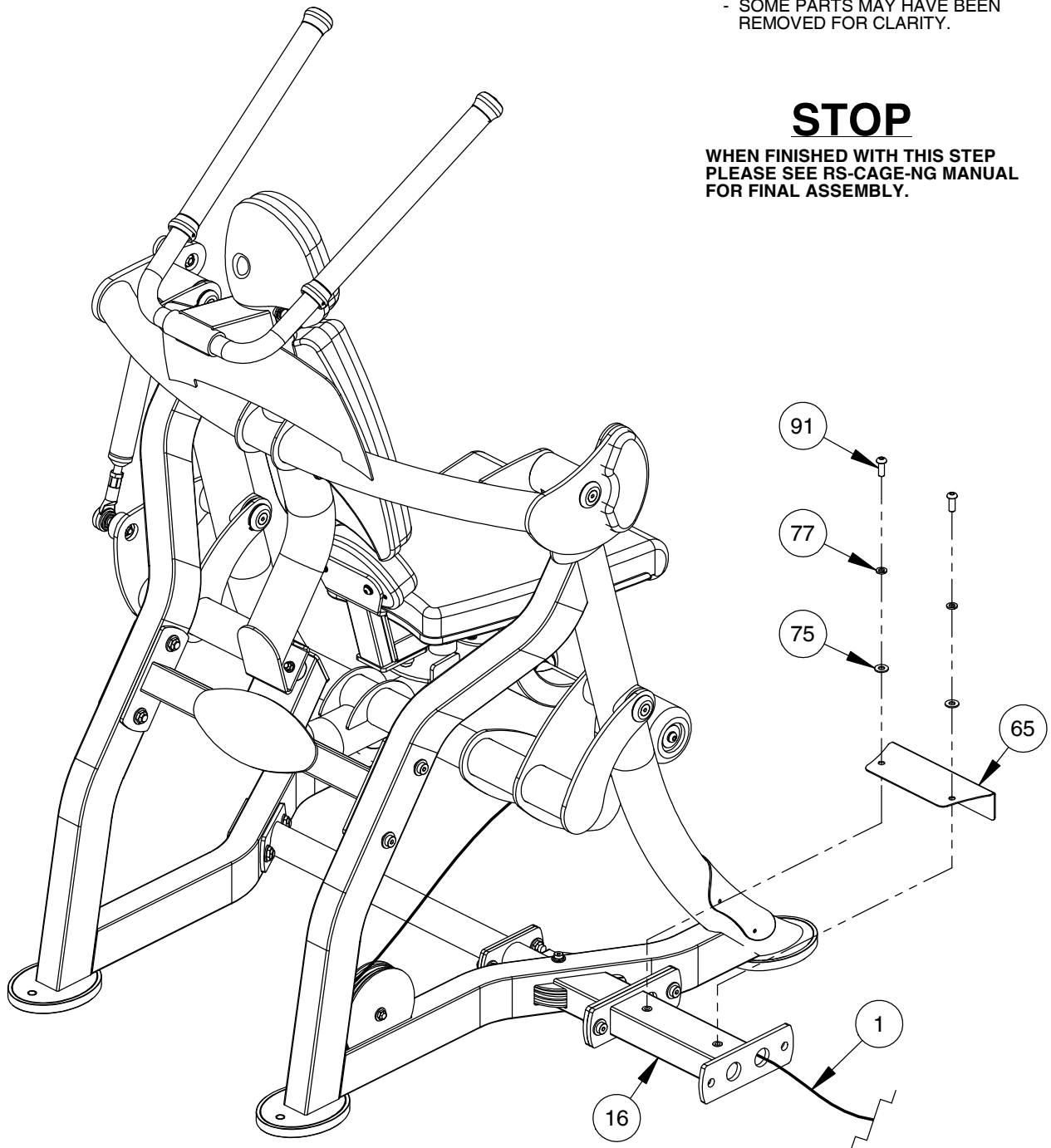

IMPORTANT

NOW THAT THE RS-2601 IS COMPLETELY ASSEMBLED TAKE TIME TO ASSURE THAT YOUR UNIT IS ASSEMBLED SQUARE AND PERPENDICULAR. IF NOT, IT WILL BE NECESSARY TO LOOSEN SOME FRAME HARDWARE TO RE-ALIGN THE FRAME AND RETIGHTEN BOLTS.

OWNER'S MANUAL

PRE-ASSEMBLY

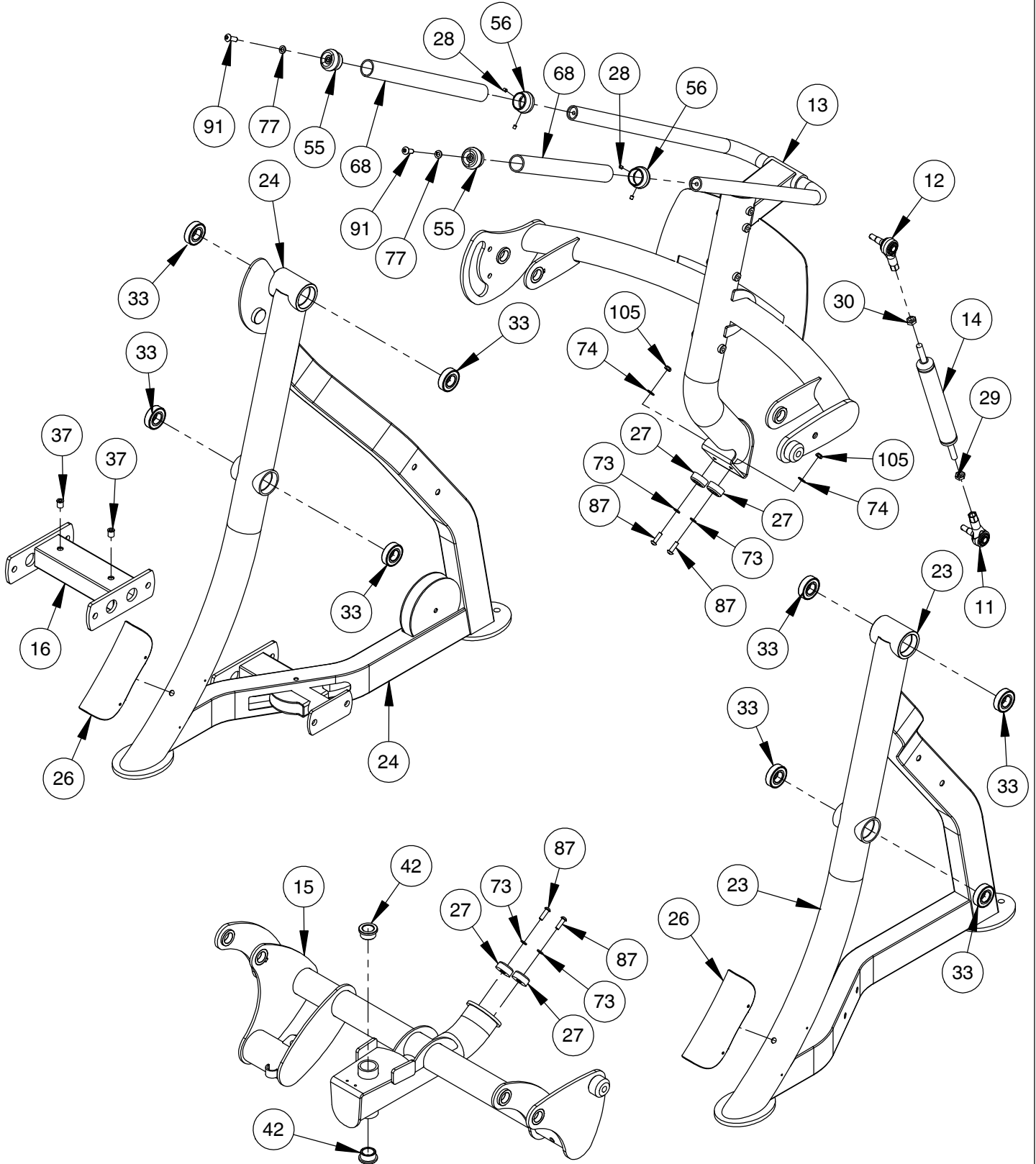

OWNER'S MANUAL

PRE-ASSEMBLY (CONTINUED)

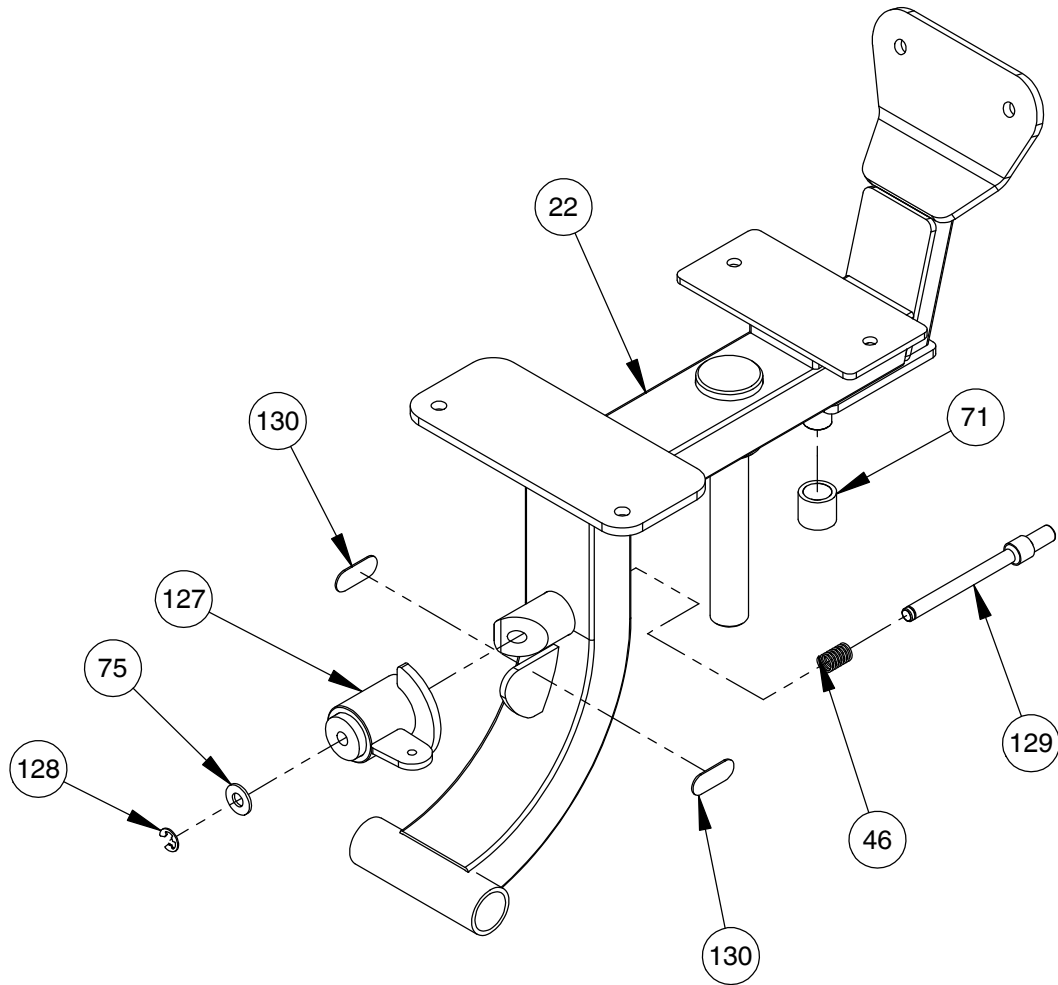

OWNER'S MANUAL

DECAL PLACEMENT

NOTE:
- ALL DECALS ARE CENTERED
UNLESS OTHERWISE STATED.

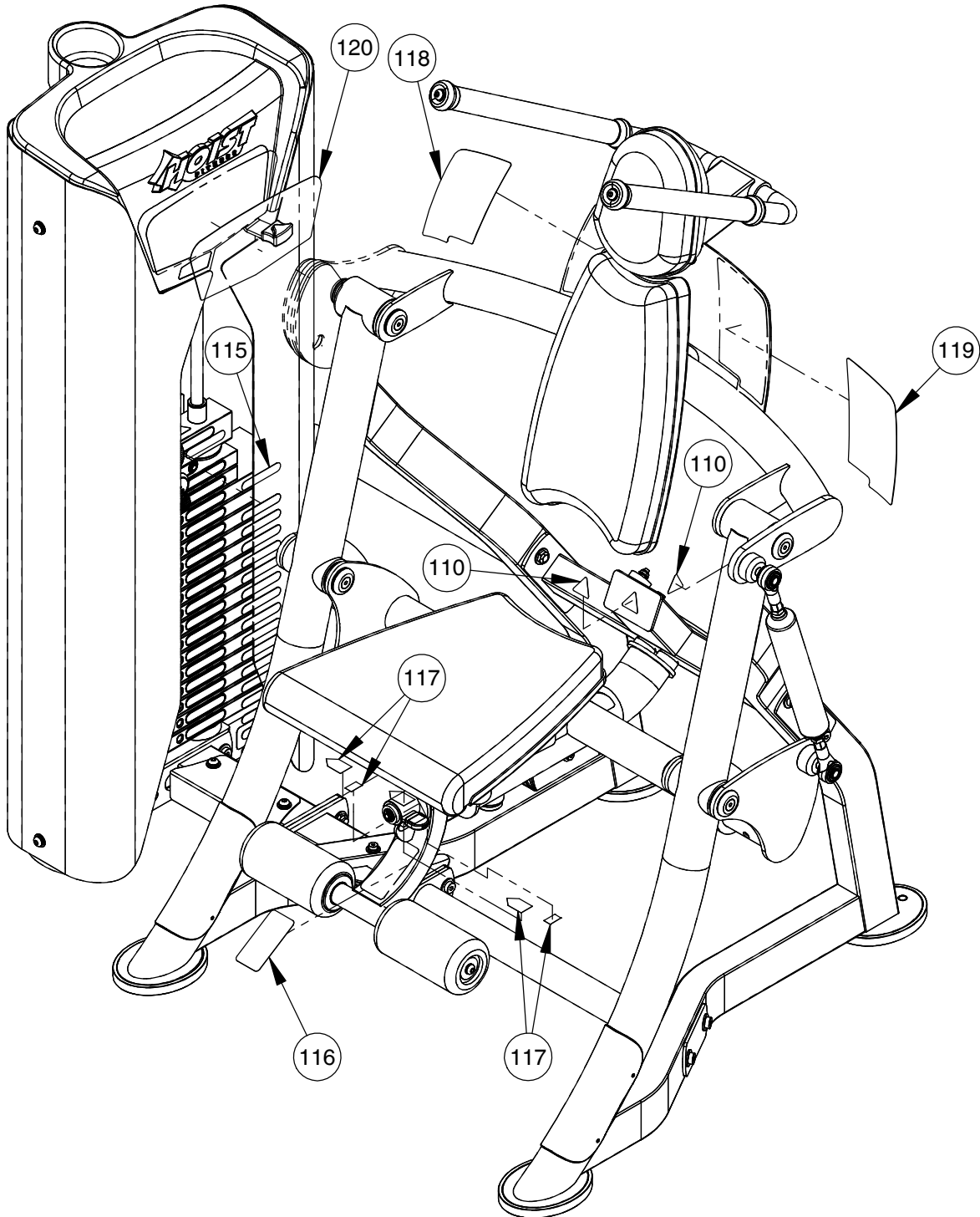

OWNER'S MANUAL

DECAL PLACEMENT (CONTINUED)

NOTE:
- ALL DECALS ARE CENTERED
UNLESS OTHERWISE STATED.

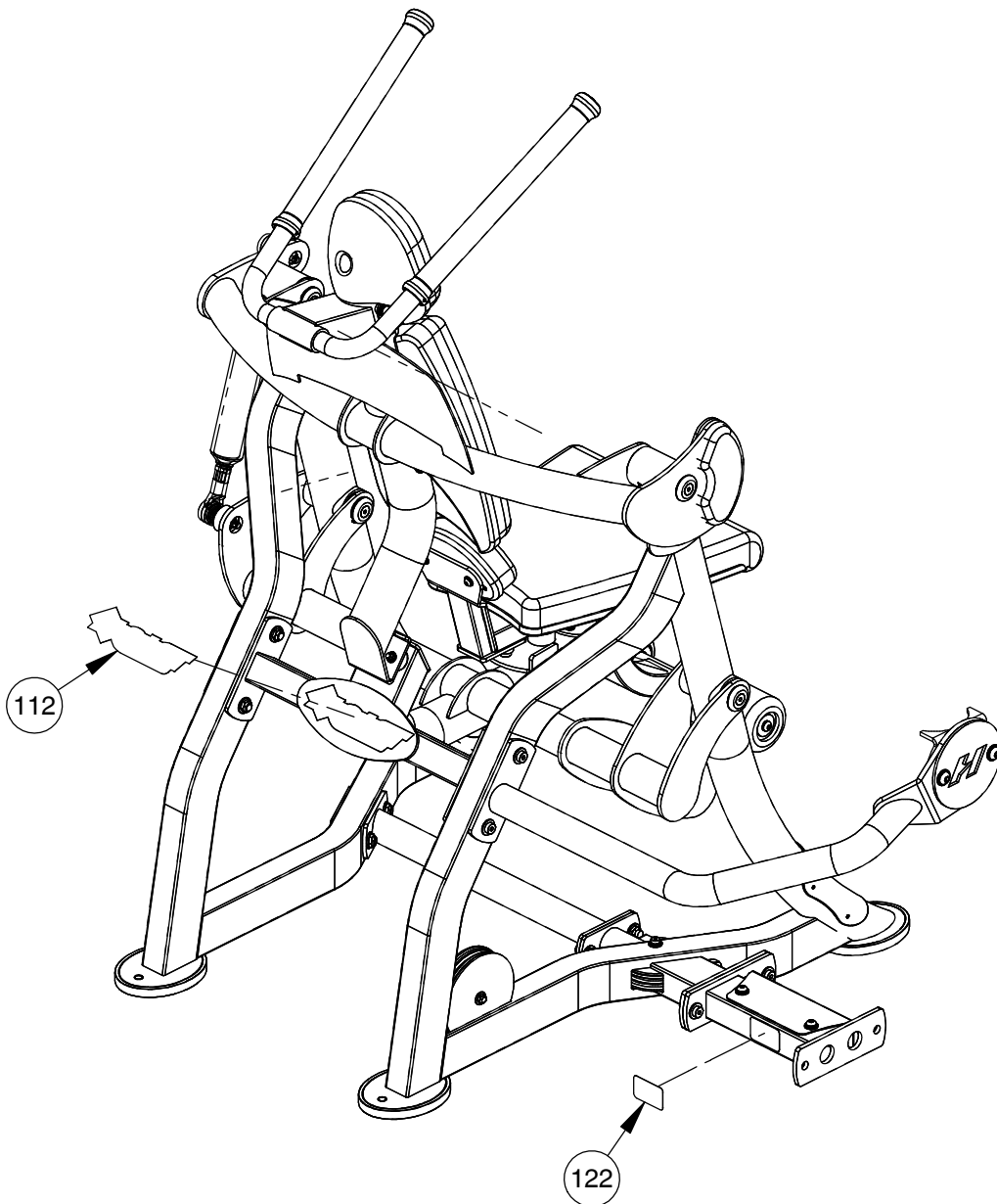

OWNER'S MANUAL

DECAL REFERENCE

15 LBS / 7 KGS	155 LBS / 70 KGS	315 LBS / 143 KGS
25 LBS / 11 KGS	175 LBS / 79 KGS	335 LBS / 152 KGS
35 LBS / 16 KGS	195 LBS / 88 KGS	
55 LBS / 25 KGS	215 LBS / 98 KGS	
75 LBS / 34 KGS	235 LBS / 107 KGS	
95 LBS / 43 KGS	255 LBS / 116 KGS	
115 LBS / 52 KGS	275 LBS / 125 KGS	
135 LBS / 61 KGS	295 LBS / 134 KGS	

021-0004241



021-0003221

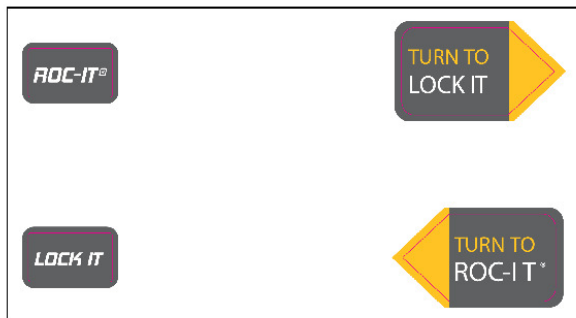

021-0003881

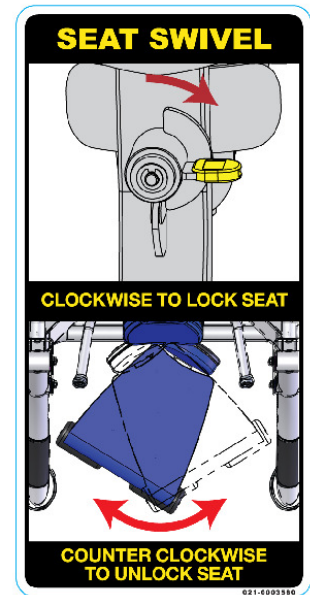

021-0003560



021-0003512



www.hoistfitness.com

Serial # 00-00-A00-000000



SERIAL # DECAL

OWNER'S MANUAL

DECAL REFERENCE (CONTINUED)

ABDOMINALS

Designed by HOIST in California

RS-2601

OBLIQUE CRUNCH

1. Sit with back against pad and seat in unlocked position with knees to the side of your body.
2. Grasp handles and place feet behind roller pads.
3. Pull handles down while raising knees.

SWIVEL SEAT

ROTATING CRUNCH

1. Sit with back against pad and seat in unlocked position.
2. Grasp handles and place feet behind roller pads.
3. Pull handles down while rotating knees upward and around in a semi-circular motion.
4. Lower and continue rotating knees to complete circular motion, returning to starting position.

TWISTING OBLIQUE

1. Sit with back against pad and seat in unlocked position with knees to the side of your body.
2. Grasp handles and place feet behind roller pads.
3. Pull handles down while raising knees diagonally.

SCAN FOR WEIGHT CALCULATOR & MORE

TORSO ROTATION

1. Sit with back against pad and seat in unlocked position with knees to the side of your body.
2. Grasp handles and place feet behind roller pads.
3. Pull handles down and hold the crunch position while rotating knees from side to side.

LOCK SEAT

021-0013333

Designed by HOIST in California

CAUTION

1. Your seat is designed to move as you exercise.
2. Keep your hands on the handles.
3. Your seat will swivel side to side unless locked.
4. Read all warnings prior to use.

021-0013343

021-0013343

ABS

INSTRUCTION

1. Sit with back against pad and seat in locked position.
2. Grasp handles and place feet behind roller pads.
3. Pull handles down while raising knees towards chest.

START

EXERCISE

021-0013344

021-0013344

OWNER'S MANUAL

PART LIST

NOTE: SOME OF THESE PARTS MAY COME PRE-INSTALLED

ITEM NO.	PART NUMBER	DESCRIPTION	QTY.
1	010-01C0414	RS-1601-A CABLE ASSEMBLY 151.5001" LG.	1
2	022-01PD2073-A	HEAD PAD ASSEMBLY	1
3	022-01PD2073-5	HEAD PAD PLASTIC BACKING	1
4	022-01PD2079-A	SEAT PAD ASSEMBLY	1
5	022-01PD2081-A	BACK PAD ASSEMBLY	1
6	022-01PD2081-5	BACK PAD PLASTIC BACKING	1
7	022-01PD2082-A	HIP PAD ASSEMBLY	1
9	022-01PDR017	ROLLER PAD Ø3.75" X 7.00" LG.	2
10	026-01X0139	ROLLER BAR ASSEMBLY 17.94" LG.	1
11	026-01X3725	TIE-ROD END RIGHT HANDED ASSEMBLY	1
12	026-01X3724	TIE-ROD END LEFT HANDED	1
13	026-01X4123	BACK PAD MOUNT	1
14	026-01X3686	CONTROL LINK	1
15	026-01X4124	LOWER PIVOTING ASSEMBLY	1
16	026-01X3762	CROSS MEMBER ASSEMBLY	1
17	026-01X3763	LOWER CROSS BAR ASSEMBLY	1
18	026-01X3783	CROSSMEMBER ASSEMBLY	1
19	026-01X3784	BENT CROSS BAR ASSEMBLY	1
20	026-01X5578	LATCH ASSEMBLY	1
22	026-01X5956	SEAT MOUNT ASSEMBLY	1
23	026-01X4125	LEFT SIDE ASSEMBLY	1
24	026-01X4126	RIGHT SIDE ASSEMBLY	1
26	026-01PL2516	SCUFF GUARD (CURVED) 8.63" LG. W/ RIVETS	2
27	019-0001003	BUMPER Ø 1.50" X .625" T	4
28	011-0711001	SET SCREW: 1/4"-28 X .25" LG. (Ni)	4
29	012-0105007	1/2-20 JAMNUT RH	1
30	012-0105012	1/2-20 JAMNUT LH	1
31	014-0011001	NYLINER BUSHING: Ø 1.09" O.D. X Ø 1.00" I.D X 1.13" LG.	2
33	014-0012014	BEARING: FLANGELESS - 25mm I.D.	8
37	014-0014002	3/8-16 FLUSH MOUNT INSERT	2
39	014-0015019	7/16" EXTERNAL RETAINING RING	1
40	014-0024001	THRUST WASHER, 1"	2

OWNER'S MANUAL

PART LIST CONTINUED

NOTE: SOME OF THESE PARTS MAY COME PRE-INSTALLED

ITEM NO.	PART NUMBER	DESCRIPTION	QTY.
41	014-0101031	BUSHING: OILITE 1.50" OD X 1.00" ID X .127" THICK	1
42	014-0101017	BUSHING: OILITE FLANGED Ø1.03" ID X Ø1.38" OD X .75" LG.	2
44	018-0002017	PULLEY 6.00" OD	1
45	018-0001003	CABLE PULLEY: Ø4.50"	1
46	020-0011023	CENTURY 71736	1
48	026-01F0289	FLANGE	1
49	026-01F0307	FLANGE: 2 HOLES 6.25" X 2.50"	1
53	026-01M0239	ALUMINUM FLATHEAD CAP Ø1.63" X .31" LG.	1
54	026-01M0836	QUICK RELEASE CABLE LOCK 1/4"	1
55	026-01M0932	ALUMINIUM CAP: Ø1.25" ID	2
56	026-01M0933	ALUMINUM RING: Ø1.25" ID	2
57	026-01M3605	RETAINING CAP	8
59	026-01M3875	PIVOT SHAFT	4
62	026-01P2653	'H' PLATE	1
63	026-01P2907	HEAD BRACKET MOUNT	1
64	026-01P2929	BACK BRACKET MOUNT	2
65	026-01P4112	CABLE SHIELD	1
67	026-01PL0151	PLASTIC WASHER Ø2.50"	2
68	026-01PL0235-27	GRIP OPEN END Ø1.188" X 15.00" LG.	2
69	026-01PL0239	THUMB LATCH	1
70	026-01PL2122	OVAL-SHAPED RUBBER FOOT	4
71	026-01PL2188	Ø.75" X .88" RUBBER TUBE	1
72	RS-CAGE-NG	RS WEIGHT CAGE NG	1
73	013-1006002	5/16" SPLIT LOCK WASHER (Ni)	4
74	013-1002010	5/16" SAE FLAT WASHER (Ni)	16
75	013-1002007	3/8" X 22mm FLAT WASHER (Ni)	14
76	013-1010003	5/16" INTERNAL LOCK WASHER (Ni)	15
77	013-1006003	3/8" SPLIT LOCK WASHER (Ni)	15
81	013-1002008	1/4" X 16mm SAE FLAT WASHER (Ni)	4
82	013-1003001	3/8" FENDER WASHER (Ni)	2
83	013-1002006	1/2" X 27mm SAE FLAT WASHER (Ni)	28
85	011-0701077	1/4"-20UNC X 1.00" BHCS (Ni)	2
87	011-0701003	5/16"-18UNC X 1.00" BHCS (Ni)	13
88	011-0701004	5/16"-18UNC X 1.25" BHCS (Ni)	6

OWNER'S MANUAL

PART LIST CONTINUED

NOTE: SOME OF THESE PARTS MAY COME PRE-INSTALLED

ITEM NO.	PART NUMBER	DESCRIPTION	QTY.
91	011-0701020	3/8"-16UNC X 1.00" BHCS (Ni)	14
93	011-0702020	3/8"-16UNC X 1.00" FHCS (Ni) W/NYLON PATCH	9
95	011-0701049	1/2"-13UNC X 1.50" BHCS (Ni)	2
96	011-0116108	1/2"-13UNC X 1.25" LOW HEAD SHCS (Ni)	4
97	011-0116145	3/8"-16UNC X 1.75" LOW HEAD SHCS (Ni)	1
99	011-0116150	3/8"-16UNC X 3.00" LOW HEAD SHCS (Ni)	1
100	011-0116115	1/2"-13UNC X 3.00" LOW HEAD SHCS (Ni)	6
101	011-0116116	1/2"-13UNC X 3.25" LOW HEAD SHCS (Ni)	2
104	012-0504004	1/4"-20 UNC THIN NYLOCK NUT (Ni)	2
105	012-0504006	5/16"-18UNC THIN NYLOCK NUT (Ni)	2
106	012-0504005	3/8"-16 UNC THIN NYLOCK NUT (Ni)	1
107	012-0504002	1/2"-13 UNC THIN NYLOCK NUT (Ni)	14
108	012-0504003	12mm x 1.25mm THIN NYLOCK NUT (Ni)	2
110	021-0003512	DECAL PINCH POINT 1.18" X 1.35" (TRIANGLE)	2
112	021-0003221	DECAL HOIST 2.50" X 9.13"	1
115	021-0004241	WEIGHT STACK #26: 335LB WEIGHT STACK DECALS	1
116	021-0003560	DECAL LEVER ADJUST 2.00" X 4.00" (VERTICAL)	1
117	021-0003881	ROC-N-LOC DECALS	1
118	021-0013343	ROC-IT-AB PLACARD (LEFT)	1
119	021-0013344	ROC-IT-AB PLACARD (RIGHT)	1
120	021-0013333	RS-2601 PLACARD	1
122	SERIAL # DECAL	DECAL HOIST SERIAL # 1.63" X 2.63"	1
127	026-01X5950	SWITCH LEVER	1
128	014-0015009	.375 E-CLIP	1
129	026-01M3228	PULL PIN PLUNGER	1
130	026-01PL2489	.0500" RUBBERIZED NON-SKID (BLACK), ADHESIVE BACKED	2
131	026-01PL2950	COVER	1
132	011-0002049	#10-32 X 58 FHB (Ni) Alloy Steel Flat-Head Socket Cap Screw	2
134	026-01P7210	ROTATION LOCK	4
135	WT-STK #26	335 LBS STACK (15LB TOP WEIGHT W/ 18 HOLE STEM)	1

OWNER'S MANUAL

ABBREVIATIONS

BZ = Black Zinc
Ni = Nickel Plated
SS = Stainless Steel
WZ = White Zinc

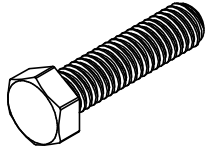

HHB = Hex Head Bolt

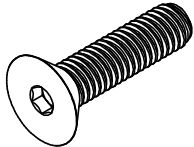

FHCS = Flat Head Cap Screw

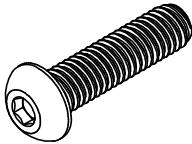

BHCS = Button Head Cap Screw

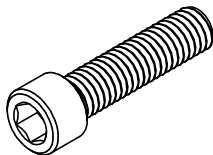

SHCS = Socket Head Cap Screw

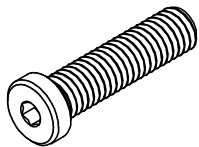

Low Head SHCS = Low Head Socket
Head Cap Screw

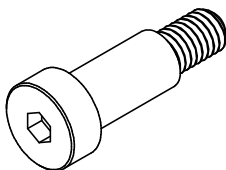

SHSS = Socket Head Shoulder Screw

OWNER'S MANUAL

BOLT SIZING CHART

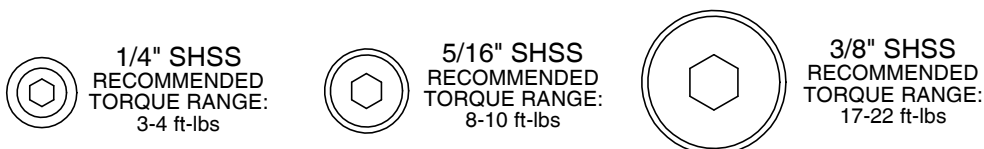
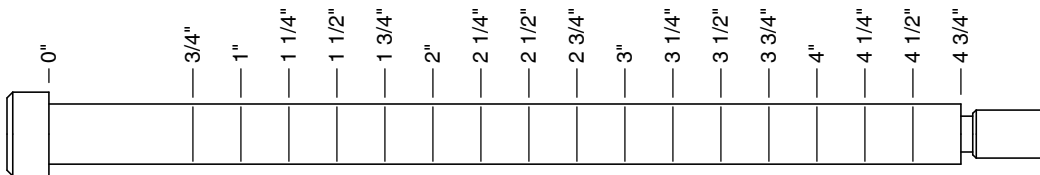
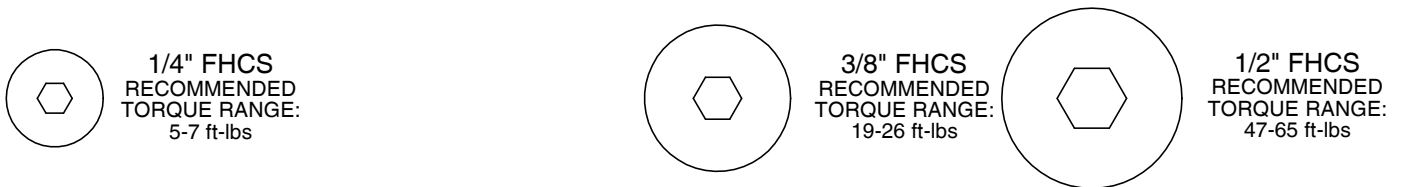
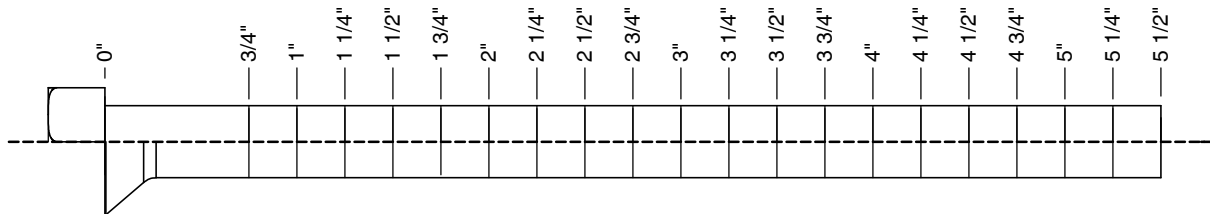
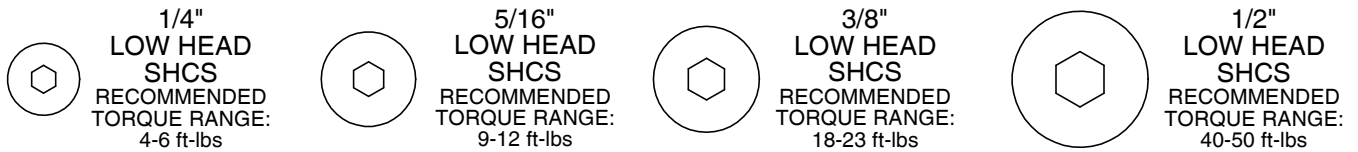
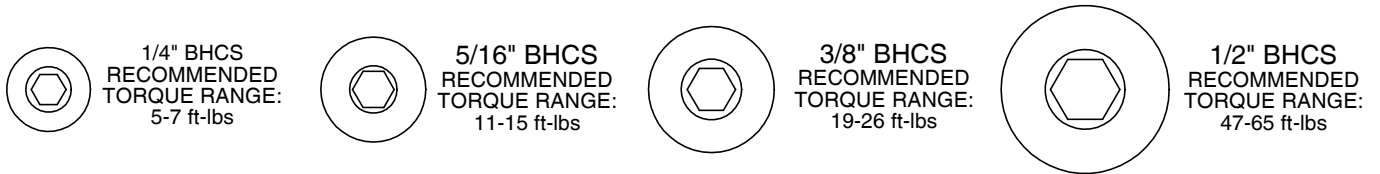
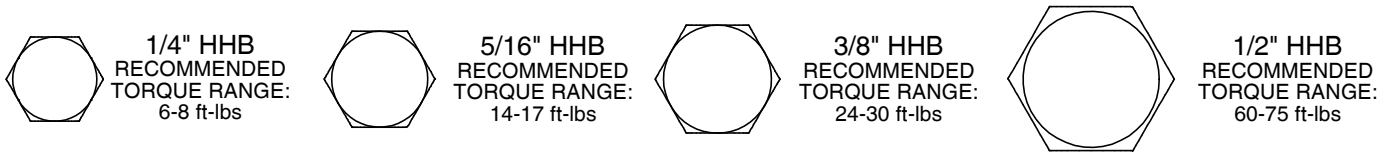

OWNER'S MANUAL

WASHER SIZING CHART

013-0002003
1/4"
FLAT WASHER
SMALL, SAE, 13mm

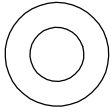

013-0102004
5/16"
FLAT WASHER
LARGE, USS, 22mm

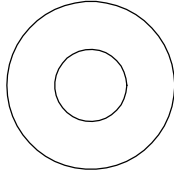

013-0002004
3/8"
FLAT WASHER
SMALL, SAE, 21mm

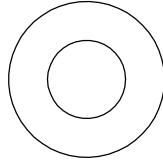

013-0402005
3/8"
FLAT WASHER
LARGE, USS, 25mm

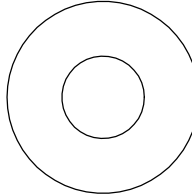

013-0102003
1/2"
FLAT WASHER
SMALL, SAE, 27mm

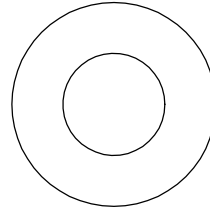

013-0102026
1/2"
FLAT WASHER
LARGE, USS, 34mm

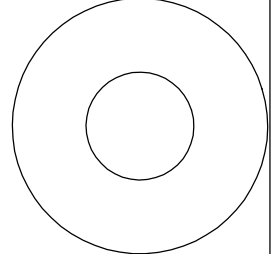

013-0102028
3/8"
CURVED WASHER

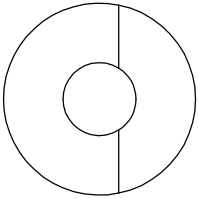

013-0402007
3/8"
FLAT WASHER
22mm O.D.

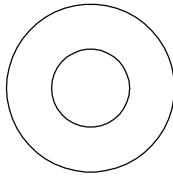

013-0102019
1/4"
LOCK WASHER



013-0102020
3/8"
LOCK WASHER

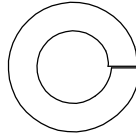

013-0102018
1/2"
LOCK WASHER

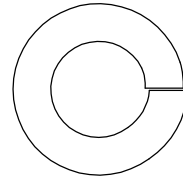

014-0018001
1/2" LONG
SPACER

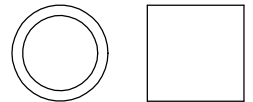

026-01M0238
2" ALUMINUM
FLATHEAD CAP

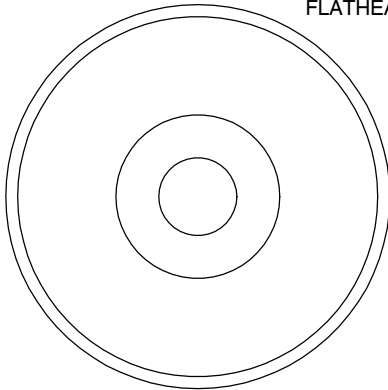

016-0009003
1" SHIM WASHER

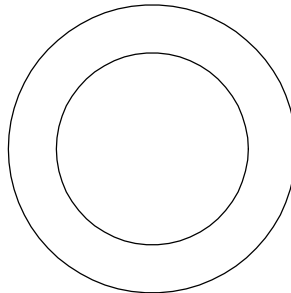

013-0003002
3/8" FENDER WASHER

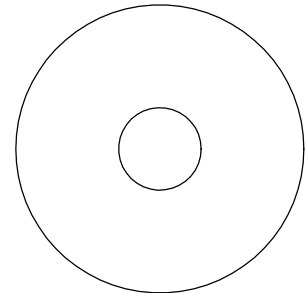

013-0003004
1 1/16"
FENDER WASHER

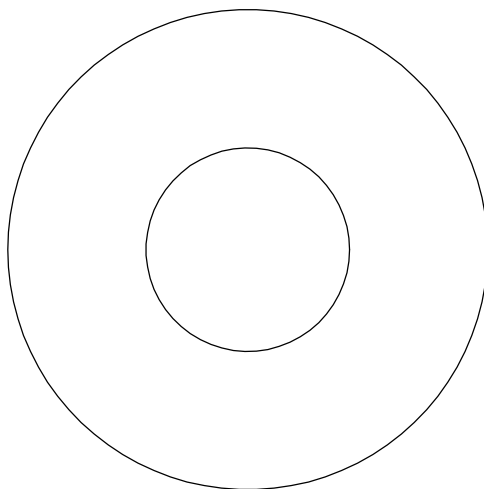

026-01PL151
PLASTIC 1 1/16"
FENDER WASHER

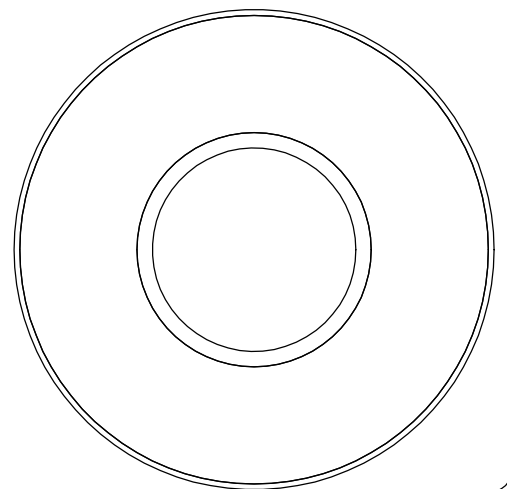

014-0018002
1" LONG
SPACER

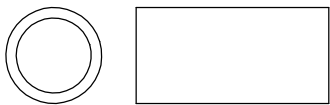

OWNER'S MANUAL

WASHER SIZING CHART (CONTINUED)

026-01M0211
1/4" LONG
FLANGED SPACER

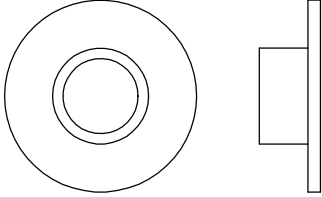

026-01M0198
1/2" LONG
FLANGED SPACER

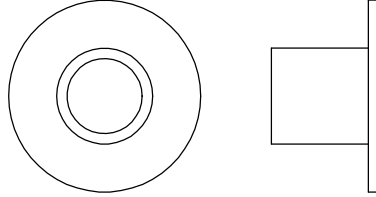

026-01M0760
1/2" LONG HEAVY
FLANGED SPACER

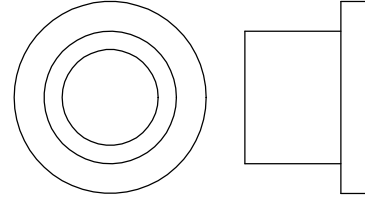

026-01M211T
1/4" LONG HEAVY
FLANGED SPACER

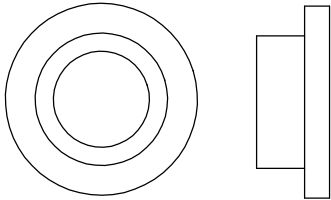

026-01M0532
11/16" LONG HEAVY
FLANGED SPACER

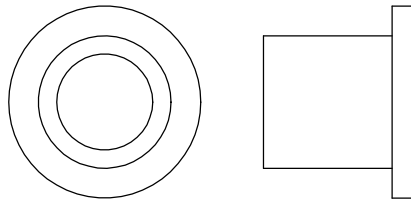

026-01M0551
1" LONG HEAVY
FLANGED SPACER

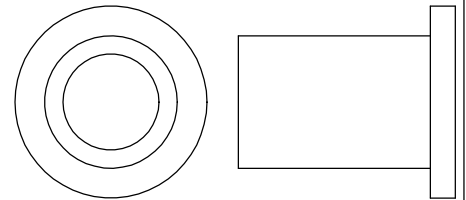

026-01M0788
.81" LONG HEAVY
FLANGED SPACER

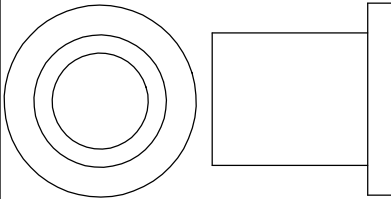

026-01M0780
.65" LONG HEAVY
FLANGED SPACER

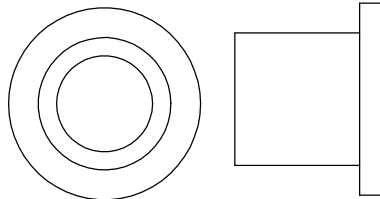

026-01M0761
1 11/16" LONG HEAVY
FLANGED SPACER

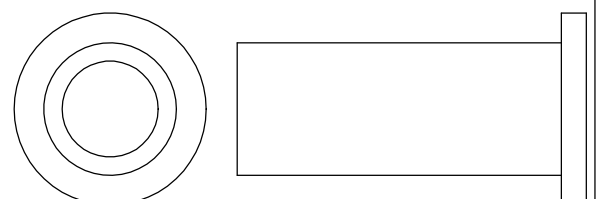

026-01M0789
.44" LONG HEAVY
FLANGED SPACER

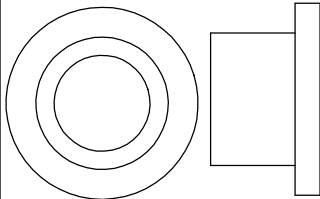

026-01M0762
1 1/2" LONG HEAVY
FLANGED SPACER

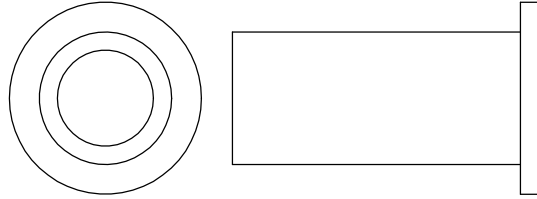

026-01M0768
1 1/4" LONG HEAVY
FLANGED SPACER

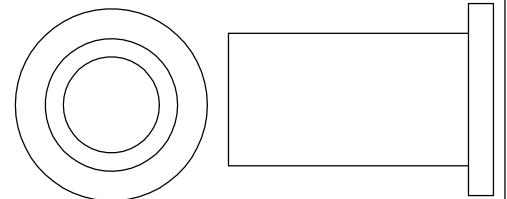

026-01M0600
.625" LONG
FLANGED SPACER

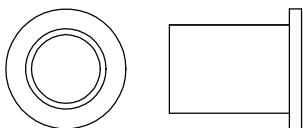

026-01M0240
1 3/8" ALUMINUM
FLATHEAD CAP

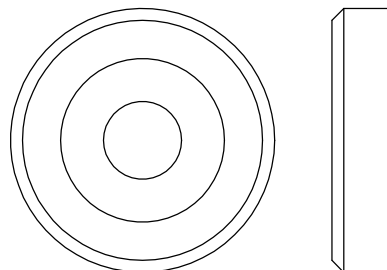

026-01M0239
1 5/8" ALUMINUM
FLATHEAD CAP

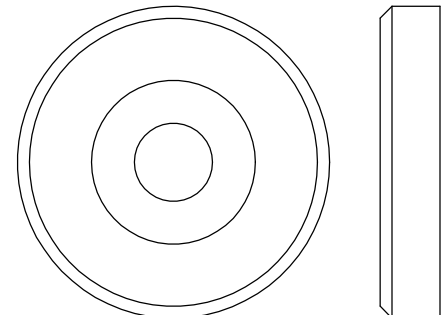

OWNER'S MANUAL

MAINTENANCE SCHEDULE

ROUTINE	COMMERCIAL / LIGHT COMMERCIAL MAINTENANCE	HOME MAINTENANCE	LATEST DATE ENTRY																	
Inspect; Links, Pull Pins, Snap Locks, Swivels, Weight Stack Pins	DAILY	WEEKLY																		
Clean; Upholstery	DAILY	WEEKLY																		
Inspect; Cables or Belts and their tension	DAILY	WEEKLY																		
Inspect; Accessory Bars, and Handles	WEEKLY	3 MONTHS																		
Inspect; All Decals	WEEKLY	3 MONTHS																		
Inspect; All Nuts and Bolts, Tighten if needed	WEEKLY	3 MONTHS																		
Inspect; Anti-Skid Surface	WEEKLY	3 MONTHS																		
Clean & Lubricate; Guide Rods with a Teflon (PTFE) based lubricant (Superlube)	MONTHLY	3 MONTHS																		
Lubricate; Seat Sleeves, Turcite Bushings, Linear Bearing	MONTHLY	3 MONTHS																		
Clean and Wax; All Glossy Finishes	6 MONTHS	YEARLY																		
Repack with Grease; Linear Bearings	6 MONTHS	YEARLY																		
Replace; Cables, Belts and Connecting Parts	YEARLY	3 YEARS																		

*Your equipment comes with a commercial maintenance decal.
For personal, in home use, please follow the home maintenance schedule listed above.*

Never use ammonia, acid-based, or petroleum-based solvents on any portion of the machine as it may damage the finish.

OWNER'S MANUAL

HOIST FITNESS SYSTEMS **GENERAL MAINTENANCE INFORMATION**

Links, Pull-Pins, Snap Hooks, Swivels, Weight Stack Pins:

- *Check all pieces for signs of visible wear or damage.
- *Check springs in snap hooks and pull-pins for proper tension and alignment.
- *If the spring sticks or has lost its rigidity, replace it immediately.

Upholstery:

- *To ensure prolonged upholstery life and proper hygiene, all upholstered pads should be wiped down with a damp cloth after every workout.
- *Periodically take the time to use a mild soap or an approved vinyl upholstery cleaner to deter the onset of cracking or drying. Avoid using any abrasive cleaners or cleaners not intended for use on vinyl.
- *Replace ripped or worn upholstery immediately.
- *Keep sharp or pointed objects clear of all upholstery.

Decals:

- *Inspect and familiarize yourself with any safety warnings or other user information posted on each decal.

Nuts and Bolts:

- *Inspect all nuts and bolts for any loosening and tighten if needed.
- *Go through a re-tightening sequence periodically to ensure that all hardware is tensioned properly.

Anti-Skid Surfaces:

- *These surfaces are designed to supply secure footing and need to be replaced if they appear worn or become slippery.

Belts and Cables:

- *Hoist uses only high quality belt, and mil-spec cables.
- *Visually inspect the belts and cables for fraying, cracking, peeling or discoloration.
- *While the machine is not in use, carefully run your fingers along the belt or cable to feel for thinning or bulging areas.
- *Replace belts and cables immediately at the first signs of damage or wear. Do not use equipment until belts or cables have been replaced.

Belt and Cable Tension:

- *Referring to the Owners Manual, when belts or cables are used check all bolts attachments to be sure they are properly attached.
- *Check slack in cables and re-adjust cable tension if needed.

Seat Sleeves, Guide Rods:

- *Wipe down adjusting tubes with a dust free rag before applying lubricant.
- *Lubricate seat sleeves and Guide Rods with a Silicon or Teflon based lubricant spray.

Linear Bearings:

- *Referring to the Owners Manual carefully disassemble the bearing from its housing and place a finger full of light grease (lithium, super lube, etc.) into the inside of the bearing. Using your finger, press the grease into the ball-bearings and their tracks. repeat until the ball-bearing tracks are full of grease. Insert the shaft back into the bearing and wipe off excess grease.

PLEASE KEEP THIS FOR YOUR RECORDS

OWNER'S MANUAL

WEIGHT TRAINING TIPS

In order to gain maximum results from your RS-2601 and to avoid possible injury, always consult your physician before starting any exercise program and consult a fitness professional to develop your complete exercise program.

To be successful in your exercise program, it is important to develop an understanding of the basic principles of strength training. Now that you have your RS-2601, it is only natural that you want to get started immediately. First, determine a set of realistic goals and objectives for yourself. By deciding on an exercise plan that is right for you prior to starting, you will contribute significantly to your success.

Warm up properly before engaging in weight resistance training. Stretching, yoga, jogging, calisthenics or other cardiovascular exercise can help prepare your body for the heavier workload of lifting weights.

Learn how to perform the exercise correctly before using heavy weight. Correct form is important to avoid injury and to ensure that you work the proper muscle groups.

Know your limitations. If you are new to weight training or are embarking on an exercise regimen after a long layoff, start slowly and build foundational strength over a longer period of time.

Pay attention to your breathing. Exhale when you exert is a general rule of thumb. Never hold your breath.

Enjoy your RS-2601!

OWNER'S MANUAL

HOIST FITNESS SYSTEMS LIMITED LIFETIME WARRANTY

Hoist Fitness Systems warrants this product to the **original purchaser** to be free from defects in workmanship and/or materials under normal use or service. If at any time a component part is defective, Hoist Fitness Systems shall repair or replace it (at Hoist Fitness Systems option) within a reasonable period of time. This warranty does not cover costs of removal, transportation or reinstallation. This warranty shall not apply if the defect was caused by misuse, neglect or normal wear and tear.

WARRANTY CLAIMS. All claims require: Model number, Serial number, Date of installation, and any information supporting the existence of the alleged defect.

To complete Warranty Registration visit:
www.HOISTFITNESS.com
and click on the Warranty Registration link

Starting from the original date of purchase, this warranty covers the following:

COMMERCIAL USE: All malfunctions of upholstery, grips, and coatings that occur up to one year; all malfunctions of belts or cables up to one year; all malfunctions of pulleys, bearings, or bushings that occur up to three years. The frame and body components are warranted for ten years, with structural moving parts warranted for five years.

LIGHT COMMERCIAL USE: All malfunctions of upholstery, grips, and coatings that occur up to one year; all malfunctions of belts or cables up to one year; all malfunctions of pulleys, bearings, or bushings that occur up to three years. The frame and body components are warranted for ten years, with structural moving parts warranted for five years.

HOME USE: All malfunctions of grips, paint, and chrome that occur up to ten years; all malfunctions of electronic components, belts, cables, or upholstery that occur up to ten years; all malfunctions of pulleys, bearings, or bushings that occur up to ten years. The frame and all welded components are warranted for the life of the product.

PLEASE NOTE THAT NOT ALL HOIST PRODUCTS ARE MADE FOR COMMERCIAL USE. Refer to the instructions page of your owner's manual or consult with you fitness product dealer to establish if a product is made for commercial use or not. Using a non-commercial product in a commercial setting can result in serious injury or death! Hoist Fitness Systems sole responsibility shall be to repair or replace the component within the terms stated above. Hoist Fitness Systems shall not be liable for any loss or damage of any kind including any incidental or consequential damages resulting, directly or indirectly from any warranty expressed or implied or any other failure of this product.

LIGHT COMMERCIAL USE: Our Light Commercial warranty applies to facilities that **DO NOT** charge monthly membership dues and where the equipment would be used by **no more than 50** people per day. Examples of Light Commercial facilities include hotels, apartment complexes, personal training studios, fire stations, police stations, etc., that meet the criteria stated above.

WHAT IS NOT COVERED BY THIS WARRANTY: Hoist's sole obligation under this warranty is limited to either repair or replacement of parts, subject to the additions below. This warranty neither assumes nor authorizes any person to assume obligations other than expressly covered by this warranty.

NO CONSEQUENTIAL DAMAGES: Hoist is not responsible for economic loss; profit loss; or special, indirect, or consequential damages.

WARRANTY IS NOT TRANSFERABLE: This warranty is not assignable and applies only in favor of the original purchaser/user to whom delivered. Any such assignment or transfer shall void the warranties herein made and shall void all warranties, expressed, implied or statutory, except the one (1) and five (5) year warranties described above. These warranties are exclusive and in lieu of all other warranties, including implied warranty and merchantability or fitness for a particular purpose. There are no warranties which extend beyond the description on the face hereof.

TRANSPORTATION COSTS: Hoist will accept parts covered under this warranty freight collect, provided that shipment has received prior approval. Hoist is not responsible for any other transportation costs but will ship freight collect parts either repaired or replaced under these warranties.

Hoist Fitness Systems
11900 Community Rd.
Poway, CA. 92064
(800)548-5438

PLEASE KEEP THIS FOR YOUR RECORDS