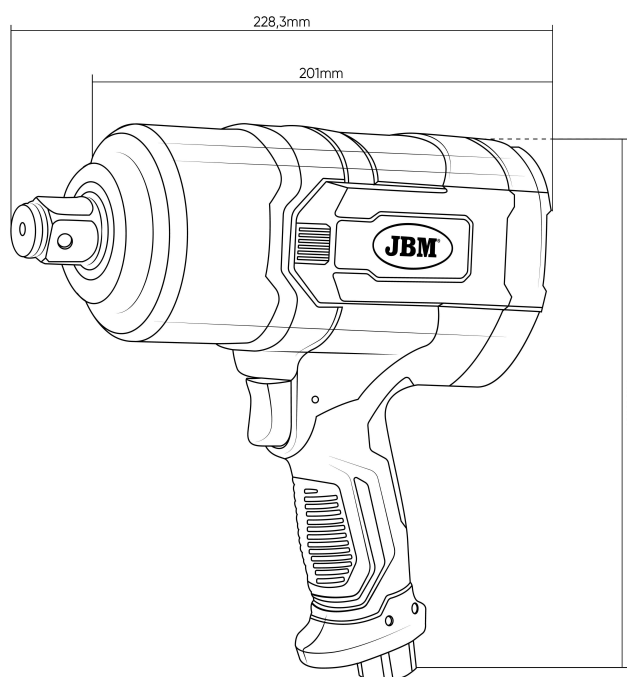

54859
3/4" IMPACT WRENCH 2300NM
TECHNICAL SPECIFICATIONS

Square measure	3/4"
Air intake	1/2"
Max. tightening torque	2000Nm
Max. breaking torque (untightening)	2300Nm
Real air consumption	9CFM (255L/min)
Nominal speed	5500RPM
Operating pressure	6,3BAR
Sound intensity	108,9dB
Hammer system	Doble/Twin
Speeds	4
Beats per minute	900
Weight	3,85Kg
Dimensions (LxWxH)	228x90x217mm

DIMENSIONES ESPECÍFICAS

JBM CAMPLLONG SL

 CIM LA SELVA - CTRA. AEROPORT KM. 1.6 NAU 2.2 CP 17185
 VILOBÍ D'ONYAR - GIRONA - ESB17419292 - SPAIN

www.jbmcamp.com
More information
Ref.



54859

3/4" IMPACT WRENCH 2300NM

SUMMARY

High-performance 3/4" pneumatic impact wrench:

- Double hammer impact mechanism for maximum power, delivering high performance.
- Maximum loosening torque: 2300 Nm, maximum tightening torque: 2000, 1500, 400 Nm (depending on selected speed).
- The grip is ergonomically designed to fit perfectly in the hand, with forward and reverse operation, easy one-hand direction change, and an ergonomic cold-insulated handle.
- Molded bumpers protect the tool from lateral impacts.