

## SERIE527

## MODULAR FURNITURE SET (11PCS) – EXTENSION WITH REF.16500 AND REF.16493



## IT CONTAINS

x1	16493	CABINET WITH 3 DRAWERS WITH PAPER REEL HOLDER (REF. 54327)
x2	16494	WALL CABINET (REF. 54327)
x1	16496	MDF BOARD 1360X500X38MM (REF. 16627/16628/16500)
x4	16498	PEG BOARD 680X340X25MM (REF.54327)
x1	16500	CABINET WITH 2 DOORS (REF.54327)
x3	16561	SUPPORT BAR (REF.54327)

COMPONENTS

16500

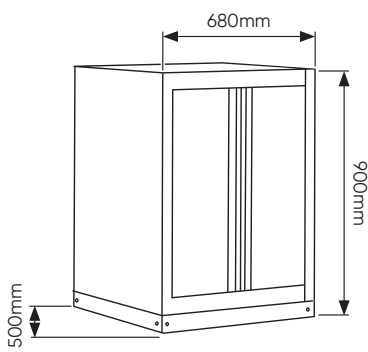

16493

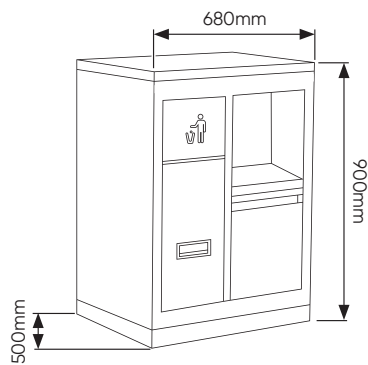

16494

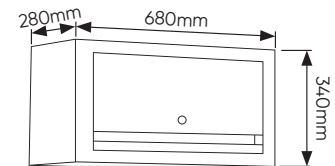

16498

338x25x680mm



16496

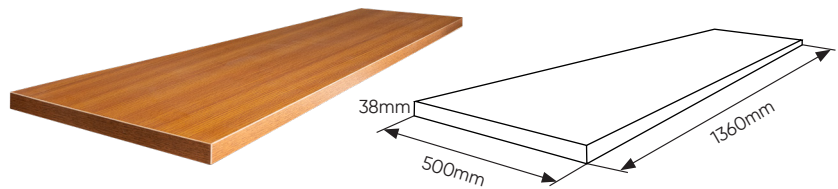

16561



COMPONENTS

SERIE527

