



Associated conference: 5th International Small Sample Test Techniques Conference

Conference location: Swansea University, Bay Campus

Conference date: 10th - 12 July 2018

How to cite: Wang, J., Chen, R., Wang, Q., & Tu, S. 2018. The research and development of small-invasive sampling machine. *Ubiquity Proceedings*, 1(S1): 25 DOI: <https://doi.org/10.5334/uproc.25>

Published on: 10 September 2018

Copyright: © 2018 The Author(s). This is an open-access article distributed under the terms of the Creative Commons Attribution 4.0 International License (CC-BY 4.0), which permits unrestricted use, distribution, and reproduction in any medium, provided the original author and source are credited. See <http://creativecommons.org/licenses/by/4.0/>.

UBIQUITY PROCEEDINGS



<https://ubiquityproceedings.com>

The research and development of small-invasive sampling machine

J. Wang *, R. Chen, Q. Wang, S. Tu

(School of mechanical engineering and power, East china university of science and technology, Shanghai, China, 200237)

* Correspondence: wangjianwen@ecust.edu.cn; Tel.: +81-021-6425-3413

Abstract: The research and development of small-invasive sampling machine (SISM), which can be used to take out small dimensional samples from in-service equipment and to provide experimental materials for hydraulic bulging test and small punch test, has important application value in Engineering practice. This paper proposed a SISM and its design considerations. The sampling trajectory plan and small dimensional sample arrangement for improving sampling material utilization have been described. A unique semispherical machine tool was designed and the preparation method and performance characterization of the tool blade coating was studied. The tool rotary cutting motion and rotary feed motion were planned. A swing-level-type centering mechanism was designed as feeding mechanism. Samples of form of spherical crown with diameter 35mm and thickness 4mm can be take down from in-service equipment.

Keywords: Small-invasive sampling machine; Online sampling; small sample; spherical machine tool

1. Introduction

People usually have an urgent need to know clearly about the service status as well as the reliability, residual life and safety status of the special equipment, especially such as the power station equipment, process equipment and pipelines and chemical devices. Therefore, it has important theoretical significance, engineering value and social benefit to monitor and evaluate the status of the equipment in service.

It is impossible to remove large material from the in-service equipment to make standard samples due to the particularity of the special equipment. People developed the small punch test technique and hydraulic bulging technique in order to evaluate the material properties of the in-service equipment. These test methods only need to take a small piece of material on the body of the in-service equipment. The shallow pits because of the sampling will generate very low stress, the shallow pits' surfaces are smooth and the shallow pits are no need to be repaired. Therefore, this micro sampling method can be considered as a sampling method that does harm to the surface of the equipment.

The tiny material removed from the equipment can be made into a small circular specimen with the thickness of 0.5mm and the diameter of 5~10mm. Small surface cracks and grain boundary inclusions can be observed under a high power optical microscope or an electron microscope. The sample can be used to evaluate the properties of fracture toughness, hardness, radiation embrittlement and so on. The sample can also be used to test the change of material behavior in tensile, fatigue, creep, and corrosive environments.

The data obtained by the micro sample test method can be directly used to establish the design criteria of special equipment, safety evaluation of in-service equipment, equipment life extension, residual life estimation, failure mode analysis, and equipment maintenance and monitoring.

Consider the conditions of the sampling site according to the requirements of the sample for the micro damage test and determine the design constraints of the micro damage fast micro-sampling machine. Finish the design and verification of the dynamic system, transmission system, cutting system, coolant system and control system of the mechanical sampling machine in a narrow space. Design and test facilities to meet different sites and different sampling equipment. Study the special bowl cutter for the sampling machine, including high strength tool steel molding, cutter edge wear resistant coating, as well as the manufacturing process of bowl cutter, tool material, tool forming process and screening of the cutter edge wear coating combination process. Stability and safety design in sampling process of sampling machine and the selection of sampling parameters.

The size of the micro sampling is shown in Figure 1, the micro sampling is spherical cap shaped. The radius R and the thickness H are related to the diameter of spherical cap L . The thickness of the micro sampling is 5 mm, the diameter of spherical cap $L=30\sim50$ mm. Each micro sampling can be made of a number of micro specimens according to their size. If the thickness of the sampling is 2mm, two rows of specimens can be made in the direction of thickness. If the thickness is 4mm, 3 or 4 rows of specimens can be made. In the plane direction, $L=40$ mm, micro

sampling can be made according to the arrangement in Figure 2. In this way, 15~35 micro specimens can be made from the removed tiny material.

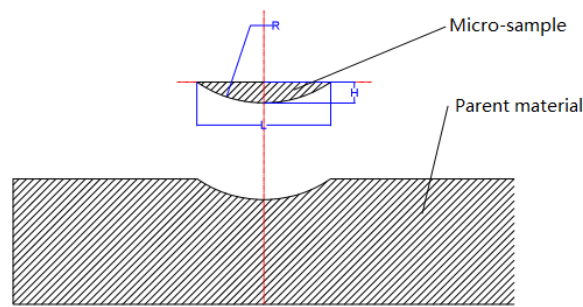

Figure 1. Size and structural shape of micro-sample.

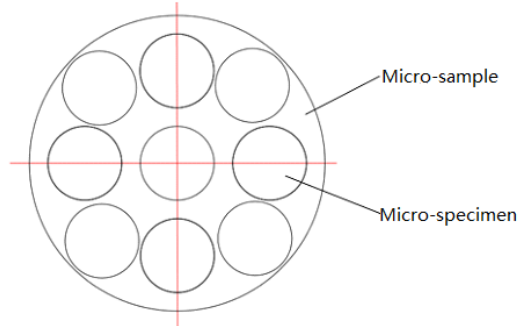

Figure 2. Arrangement of micro-specimens in the sampling.

2. Research process and overall plan

Consider the conditions of the sampling site according to the requirements of the sample for the micro damage test and determine the design constraints of the micro damage fast micro-sampling machine. Finish the design and verification of the dynamic system, transmission system, cutting system, coolant system and control system of the mechanical sampling machine in a narrow space. Facilities are designed and tested to meet different sites and different sampling equipment. Study the special bowl cutter for the sampling machine, including high strength tool steel molding, cutter edge wear resistant coating, as well as the manufacturing process of bowl cutter, tool material, tool forming process and screening of the cutter edge wear coating combination process. Stability and safety design in sampling process of sampling machine and the selection of sampling parameters. The project mainly involves the sampling machine's principle and model selection, key components research and development, mechanical components design, automatic control parameter optimization, field fixation and so on. Through debugging and improvement, manufacture a filed sampling machine with perfect function. Test the reliability of the sampling machine, analyze the material's changes of structure and performance before and after sampling, study the effect of different cutting rates on sampling efficiency and material properties, and finish the technique documents at the end.

According to the contents and ideas mentioned above, the structures and functions of the mechanical sampling machine designed and planned are shown in Figure 3.

The specific research contents are as follows:

2.1. Sampling requirements

The recommended sizes of the small punch test are 8 to 10mm in diameter and 0.25 to 0.5mm in thickness. At present, the size of the specimen in our country is usually 10mm in diameter and 0.5mm in thickness. Considering the use of EDM technology to machine micro specimens later, there will be heat affecting layers and processing lines on the specimens. So there must be machining allowances. Due to relatively more influence factors of the small punch test, enough specimens are needed to ensure the reliability of the experiments. At least 3 pieces of specimens can be taken out from each piece of sample removed to ensure the machining efficiency. Therefore, it is generally required that the minimum sampling thickness of the sampling machine should be guaranteed to be above 2-3mm (containing the heated cutting surface or mechanical damaged part). Increase the utilization of the material removed as much as possible, it is hoped that the utilization rate can reach more than 80%. In addition, the sampling

size must can be adjusted according to the size and shape of the micro specimen, the appearance of the equipment, and the size of the equipment.

2.2. Principle and structure design

There are two kinds of field sampling machines developed abroad at present, such as EDM type and mechanical type. Taking into account that the EDM type sampling cost is high and the time consuming is long, the field sampling is limited, so we use the mechanical type. As we can see from Figure 1, the following parts need to be considered during the development of a mechanical sampling machine: electric motors, spindle, cutter, fixing device, connection type, cooling methods and machining equipment after sampling. It can be roughly divided into six systems: power system, transmission system, cutting system, cooling system, control system and fixed system. The power system has the plug-in type and the mobile power type.

The cutting system and the transmission system of the sampling machine is relatively complicated. The cutting system includes the high speed rotation of the cutting tool and the low speed rotation of the tool along the sampling depth direction. The trajectory of the superposition motion of two independent motions must be calculated, so that we can implement its regular cutting function through the control system. The stability and reliability will reduced due to the vibration during the high speed cutting process. It will lead to reduction of the cutting system’s life. Through the analysis and research of the sampling location , the optimal design of the motion mechanism and the life-span design of the motion structure, we can achieve the flexible, reliable and controllable motion system. Through finite element analysis and a large number of field tests, analysis and improvement of the stability and reliability of the motion system and the cutting system, we can improve the stability of the motion system and cutting system.

Mechanical cutting will generate a lot of heat. Reasonable cooling design for the cutter of the sampling machine is necessary to avoid excessive heat effect on equipment or material. The sampling machine should have advanced control system, not only can realize the cutting function, can also adjust cutting speed and coolant supply according to different materials and the change of the temperature. The stiffness of each structure and the balance of the whole structure must also be taken into account.

2.3. Research and development of special cutting parts

The components of the field sampling machine such as motors and spindles can be purchased. At least, through reasonable selection and overall design of the whole structure, the carrying function is easy to achieve. The cutter in the sampling machine is the most important component which needs to be developed by people.

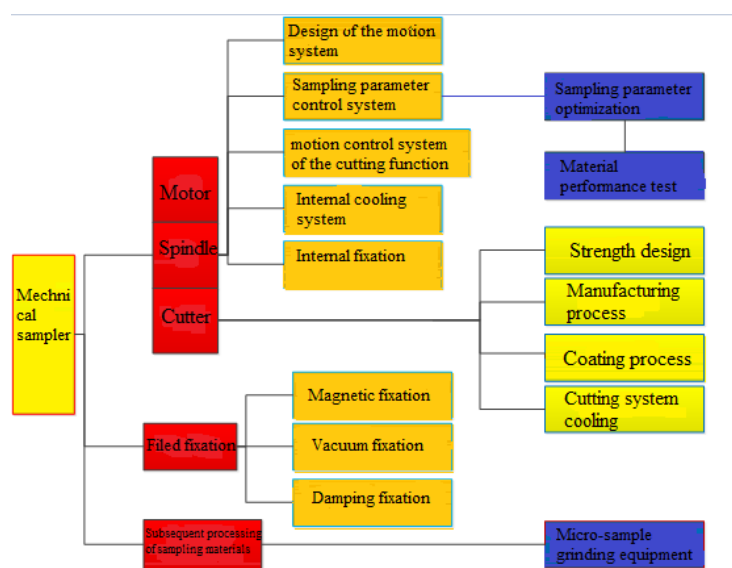

Figure 3. Structure and function of the mechanical sampling machine.

The sampling component of the sampling machine is based on the basic requirements of in-service equipment, the hemispherical cutting tool is used as the cutting tool. The hemispherical cutting tool is mainly subjected to the force of cutting and grinding, and may be subjected to the bending stress, the impact stress, the fatigue stress caused

by the vibration, etc. Firstly, it is necessary to study on the tool design, material selection, strength design and vibration analysis. Secondly, material heat treatment and processing technology of the cutting tool are essential. Lastly, the surface of the cutting tool must apply the surface preparation to improve the wear resistance and impact resistance of the surface. Through comprehensive performance test and life analysis of different combinations of high strength wear resistant tool steel and wear resistant coating to choose the optimized structure, material and coating combination to develop the cutting parts with high performance.

In the research and development of cutting parts, the most important is the shape design of grinding tools, the strength design of cutting tools, the manufacturing technology of cutting tools and the technology of abrasive coating.

2.4. Sample equivalence verification after sampling

Although there is no particular change in the micro-structure and macro-mechanical properties of the sample, but the micro-specimen is very small and susceptible to minor changes. Therefore, the issue of specimen equivalence verification after sampling must be taken into account. A small punch test or a hydraulic bulging test will be performed on the removed sample and the bulk material, and the influence of cutting on the mechanical properties of the material should be examined. The curved surfaces of different structures are separately sampled and compared on the mechanical properties of the sampling and bulk. At the same time, the micro-structure of the sample is observed for metallographic changes.

3. Results

In order to prevent the depth of the sampling from being too deep, it is necessary to strictly control the blade trajectory of the cutting tool. The cutting trajectory of the blade is shown in Figure 2.1.

According to the sampling size shown in Figure 1.1:

$$R = \frac{1}{2H} \left(H^2 + \left(\frac{L}{2} \right)^2 \right) \quad (1)$$

In the above formula, R is the radius of the cutting trajectory; H is the height of the crown, H=2~4mm; L is the diameter of the bottom of the spherical cap, L=30~50mm. In order to reduce the size of the tool and increase the safety and reliability of the operation, initially take L = 33mm, H = 5mm, which can be obtained R = 30mm. The blade of the cutting tool completes the path shown in the figure and needs to rotate $\theta = 69.7^\circ$. The overall rotation of the tool is 69.7° , which is almost impossible to achieve in the structure because it is constrained by other parts of the mechanism. On the other hand, such a large corner will inevitably lead to an oversized cutter. In order to reduce the size of the tool and the entire mechanism, consider two-way rotary cutting, so that the inclination angle of each side of the tool is 34.85° , reducing the possibility of interference.

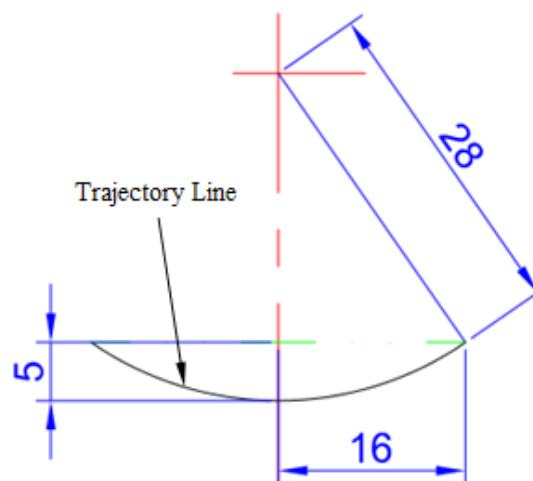

Figure 4. Tool Trajectory Line.

3.1. Tool Design and Blade Coating Preparation

The cutting edge of the tool and its subsequent part must match well with the cutting trajectory shown in Figure 4 to improve cutting efficiency, reduce interference and additional frictional resistance. The edge of the tool and the portion of the tool that is within 35° range should be as thin as possible. Other parts must maintain sufficient strength and stiffness to support the cutting motion of the tool.

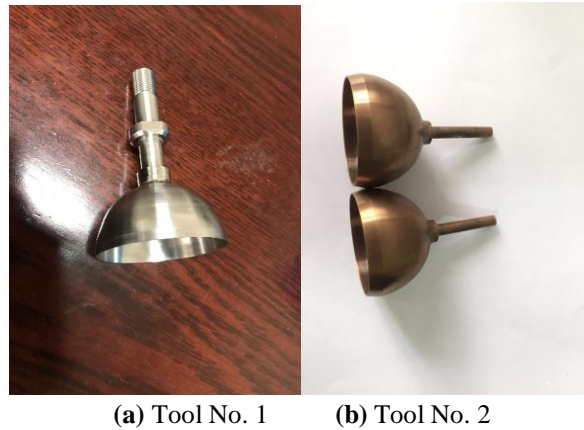

Figure 5. Designed cutting tools.

In order to test the cutting effect and determine the cutting parameters, two types of tools were preliminarily designed, such as the No. 1 and No. 2 tools shown in Figure 5.

The tool material is W6MoCr4V2 high speed steel. The material properties and chemical composition are shown in Table 1.

Table 1. High-speed steel material properties and chemical composition.

Material	Density g/cm ³	Flexural strength GPa	Hardness HRC	Chemical composition w/%				
				C	Cr	Mo	V	W
HSS	8.16	3.5~4.0	58-62	0.87	4.20	0.32	2.0	6.00

After ultrasonic cleaning of the finished tool, the tool is placed in a physical vapor deposition cathode arc ion plating apparatus, and a TiN film is formed on the blade edge as a wear-resistant layer.

Figure 6 shows the interface image of a multilayer coating substrate observed under scanning electron microscopy. It can be seen from the figure that the interface of the coating substrate is fuzzy, indicating that the bonding force is good.

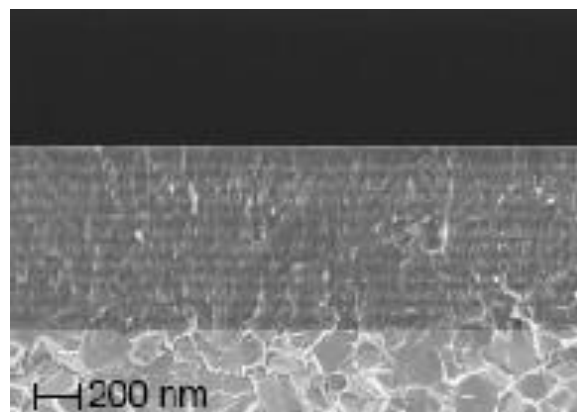

Figure 6. Photograph of the coated substrate observed under SEM.

Through using the WS-2005 automatic scratch tester that meets DIN EN ISO 14577-1:2003 "Metallic materials-hardness and material parameters of instrumental indentation test. Part 1: Test method" standard、HVS-1000 digital micro-hardness tester, kaloMAX ball mill manufactured by BAQ GmbH, Germany, and high-resolution microscopy to analyze coating thickness TiN coatings parameter was obtained as shown in table 2.

Table 2. Parameters of Prepared TiN Coatings.

Coating type	Coating thickness (μm)	Micro hardness ($\text{HV}_{0.05}$)	Deposit on temperature ($^{\circ}\text{C}$)	Membrane-based binding force (N)
TiN	3	2800	180~450	60

3.2. Feed mechanism design

The cutting motion of the tool is a high-speed rotary motion around its own axis. The rotation speed is initially set at 12,000 rpm to achieve high speed cutting. At the same time, the entire tool is deflected and moved along the trajectory shown in Fig.4. This requires that the shape of the cutting edge and front end of the cutting tool should be completely consistent with the trajectory line. Therefore, the cutting portion of the cutting tool should be consistent with the trajectory line and be a spherical structure. The more important point is: During the feed process, the cutter must keep the ball center fixed. The design of the feed mechanism needs to ensure that the position of the center of the ball is fixed and it needs to consider special operating mechanisms.

After analysis and program discussion, two kinds of solutions that can keep the center of the tool center fixed are obtained, as shown in Figure 7.

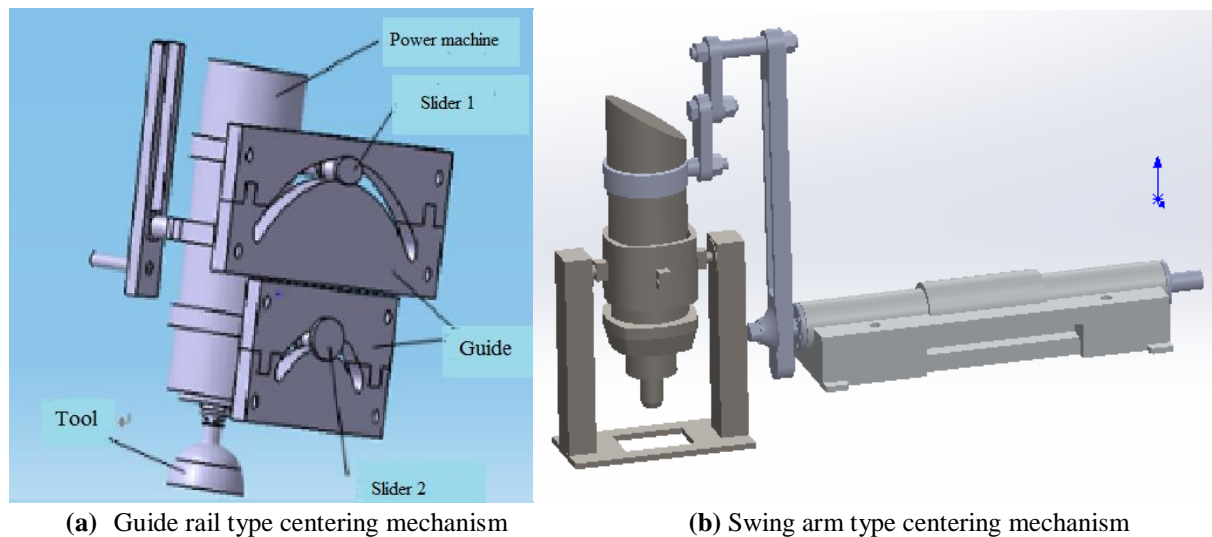

Figure 7. Cutting Feed Centering Mechanism.

In the guide rail type centering mechanism, on the one hand, the power machine drives the tool to rotate to perform cutting. On the other hand, the tool and the power machine make circular movements along the guide rails through the sliders 1 and 2 so as to ensure that the tool center is fixed. In the swing arm type centering mechanism, the swing arm swings around the rotation axis to complete the feed motion, keeping the tool center fixed. Both types have completed the design process and are under manufacturing.

3.3. Small-invasive sampling machine

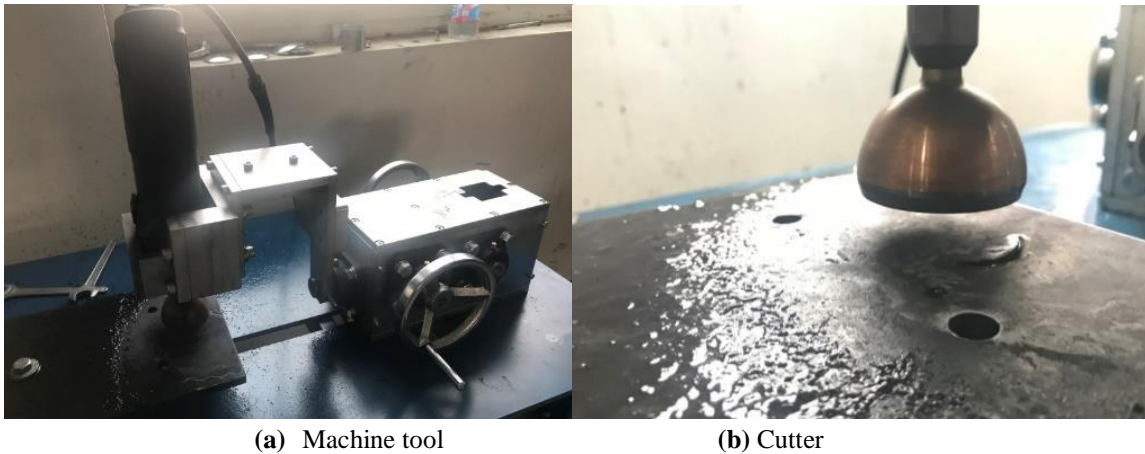

Figure 8. Machine tool and cutter.

The small- invasive sample machine has been manufactured and tested to take out small dimensional samples from a plate of 20 carbon steel. The time of sampling is about 100 minutes.

4. Conclusions

Cutting mechanism and tool design are the most critical parts of all research tasks. In the initial stage of mission implementation, due to the lack of reference materials, everything started from scratch and we were front to several difficult troubles. Fortunately, adjustments and plans were made in a timely manner, and tool trajectory studies, tool design, and tool blade coating studies, as well as the design and drawing of the cutting feed centering mechanism were successfully completed.

Acknowledgments: The present work has been supported by the China National Quality Infrastructure (NQI) No. 2016YFF0203000. The authors would like to express their gratitude to Dr. Shuqing Lin, China Special Equipment Inspection and Research Institute, Beijing, China, for his constant attention and encouragement.