

**Business of the Village Board
Village of Saranac Lake**

SUBJECT: Franklin County Occupancy Funds

DATE: 6-26-2023

DEPT OF ORIGIN: Trustee Shapiro

BILL # 91-2023

DATE SUBMITTED: 6/22/2023

EXHIBITS: _____

APPROVED AS TO FORM:

Village Attorney

Village Administration

EXPENDITURE
REQUIRED

AMOUNT
BUDGETED

APPROPRIATION
REQUIRED:

Resolution to request \$31,000 from the Franklin County Occupancy Funds to purchase and install Playground Equipment for Garwood Park

APPROVAL OF RESOLUTION

MOVED BY: Shapiro SECONDED BY: Catillaz

VOTE ON ROLL CALL:

MAYOR WILLIAMS	<u>yes</u>
TRUSTEE BRUNETTE	<u>yes</u>
TRUSTEE CATILLAZ	<u>yes</u>
TRUSTEE SCOLLIN	<u>yes</u>
TRUSTEE SHAPIRO	<u>yes</u>

Resolution to request \$31,000 from the Franklin County Occupancy Funds to purchase and install Playground Equipment for Garwood Park

WHEREAS, Garwood Park is less than 100 yards from the Adirondack Rail Trail, and,

WHEREAS, the Village of Saranac Lake wishes to improve the enjoyment of the village by families using the Adirondack Rail Trail thereby promoting tourism, and

WHEREAS, the village wants to provide improved Playground facilities for the residents of Saranac Lake, and,

WHEREAS, the village's parks manager has received a quote for \$20,746 for the equipment and the estimate for installation is \$10,000 from a state approved contractor, and

WHEREAS, the Franklin County Tourism Advisory Committee has provided funds to the village for tourism promotion.

THEREFORE, BE IT RESOLVED, the Village of Saranac Lake Board of Trustees authorizes the expenditure of \$31,000 from the occupancy tax funds for the purchase and installation of playground equipment for Garwood Park.



Challengers®

350-1717

Product: 350-1717

\$20,746

Price:

~~\$24,212~~

Sale Item!

Ages

5-12yrs

Space Required

28' 1" x 34' 1"

(8,56m x 10,39m)



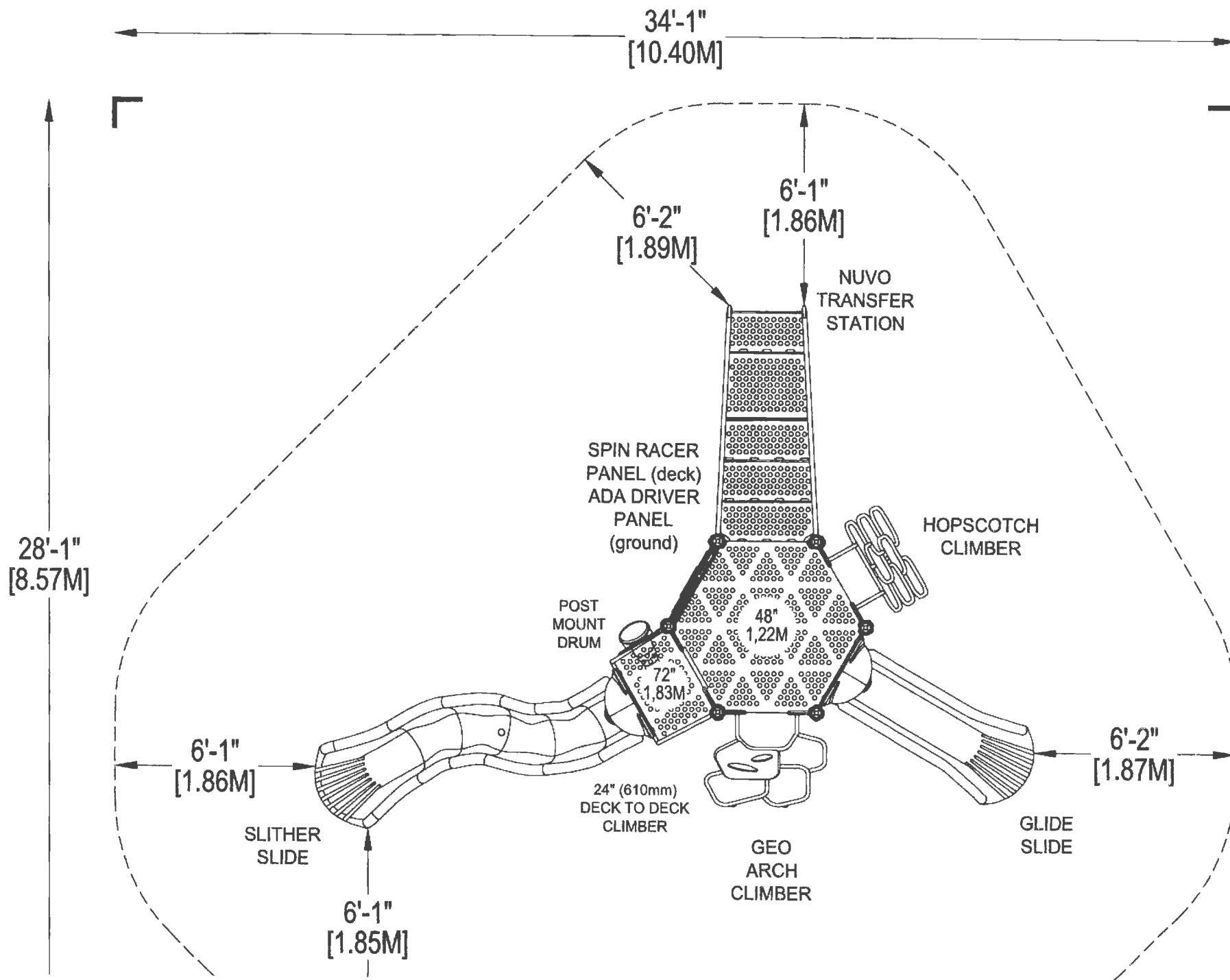

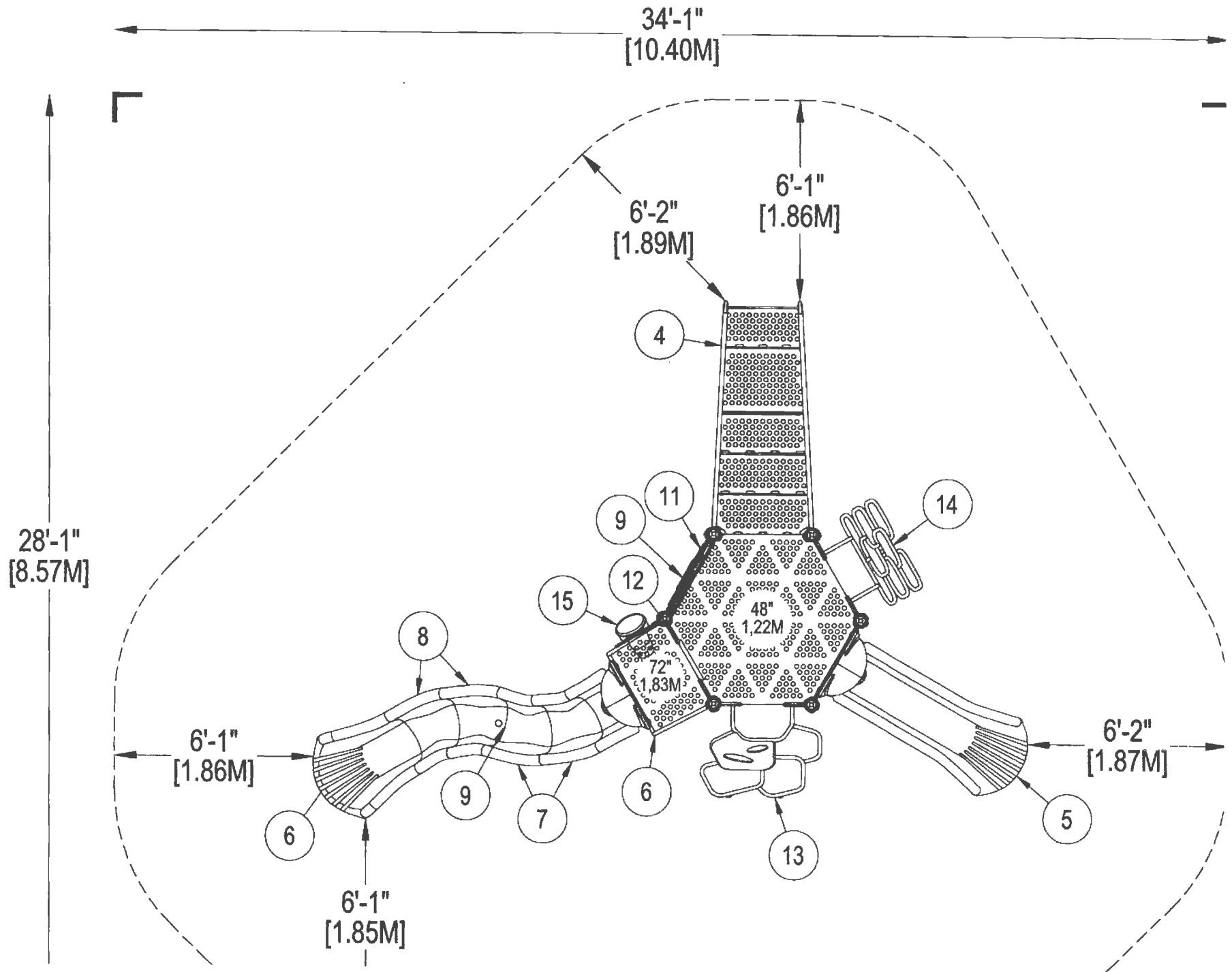

DETAIL 1

Support Post, Spiral Slide and Post Footing Detail

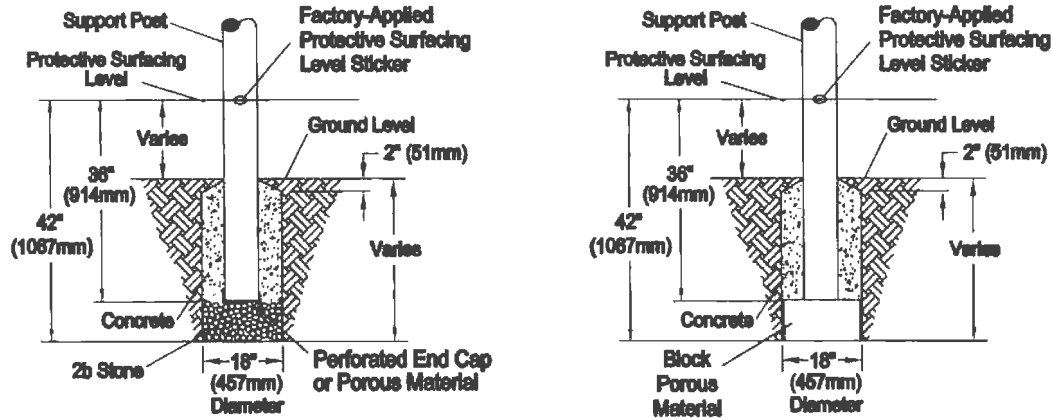

STONE OPTION

OR

BLOCK OPTION

DETAIL 2

GroundZero, Cantilever and "T" Post Footing Detail

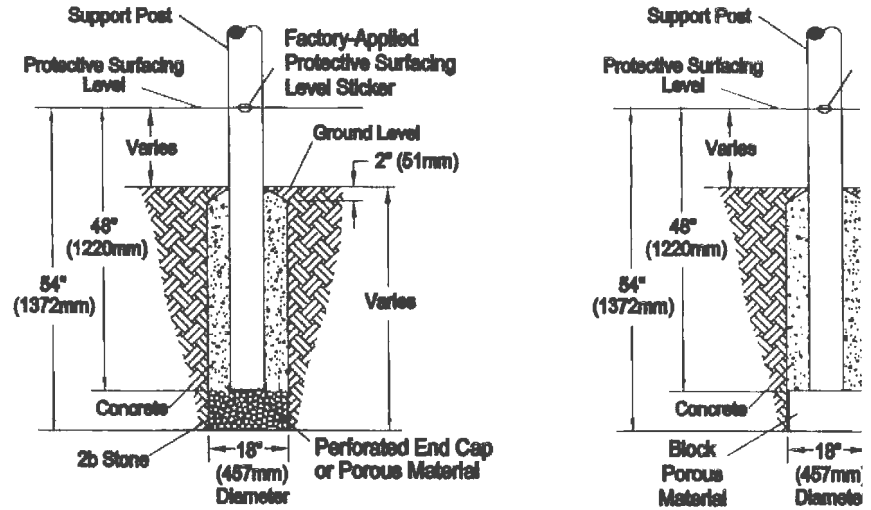

STONE OPTION

OR

BLOCK OPTION

DETAIL 3

Component Footing Detail

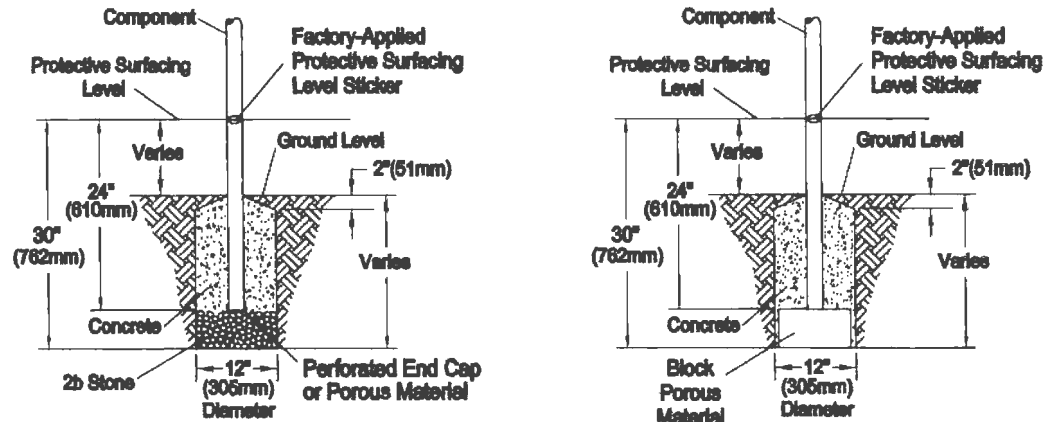

STONE OPTION

OR

BLOCK OPTION

DETAIL 4

Surface Mount Detail

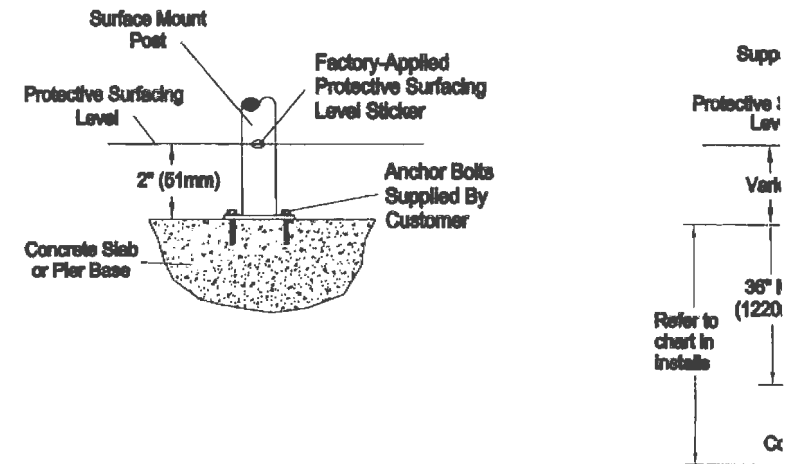

Refer to chart in installs

