

## **General building permit requirements Decks**

The following items are required to obtain a General Building Permit for a deck:

1. Any required county permits
2. Any required town or village permits
3. A completed General Building Permit Application (on-line permit instructions).  
(on-line application: [https://gec.soliant.cloud/fmi/webd/GEC\\_BuildingPermitApplication](https://gec.soliant.cloud/fmi/webd/GEC_BuildingPermitApplication))
4. Plans to scale
5. Homeowners applying for a building permit must sign the **Cautionary Statement to Owners** in accordance with s 101.65 (1r), Stats.
6. Completed deck packet

### **IMPORTANT NOTICE**

**The work you are doing under this permit must be inspected!**

Inspections for the following must be made prior to proceeding to the next phase:

1. Footings (forms in place, **prior** to pouring concrete).
2. Prior to installing decking if deck is less than 3 feet above grade.
3. After deck is completed.

**Any questions or to schedule an inspection, please call or text General Engineering at (608) 617-9253**

# Residential Deck Informational Handout

For complete code refer to SPS 321, APPENDIX B, and APPENDIX C

At website [dsps@wi.gov](mailto:dsps@wi.gov)

All lumber must be a durable species (such as western red cedar) or pressure preservative treated of grade #2 or better of the following types:

Douglas Fir/Larch, Hemlock/Fir, Spruce/Pine/Fir (SPF), and Southern Pine

Lumber in contact with the ground must be rated as **ground contact**. The lumber must be identified by the grade mark of, or certificate of inspection issued by, 'a professional lumber grading or inspection bureau or agency. **Not all treated lumber is rated for ground contact**

**See Table C-1 in Appendix C for further information.**

**Wood/plastic composites:** These materials must be labeled indicating their performance criteria and compliance with **ASTMD7032**.

**Live Load:** All decks shall be designed to support a live load of 40 pounds per square foot. **SPS 321.02**

**Fasteners:** AU fasteners must be galvanized steel, stainless steel, or approved for use with preservative treated lumber. Nails must be threaded, which includes ring shanked annular grooved, and spiral grooved. (An 1/8 inch pilot hole is recommended for all toe nailing locations). Carriage bolts may be substituted where through bolts are specified if carriage bolt washers are installed at the bolt head. (Carriage bolt washers have square holes)

**Special Design Note:** Some deck designs may not be appropriate for placement of a future screen porch or 3 season room

**Frost Footings:** Required for any deck or porch that is attached or unattached serving as an exit from a dwelling regardless of building footing. Any Landings or stoops are also required to have frost footings. The minimum depth to the base of the footing is 48". **SPS 321.16**

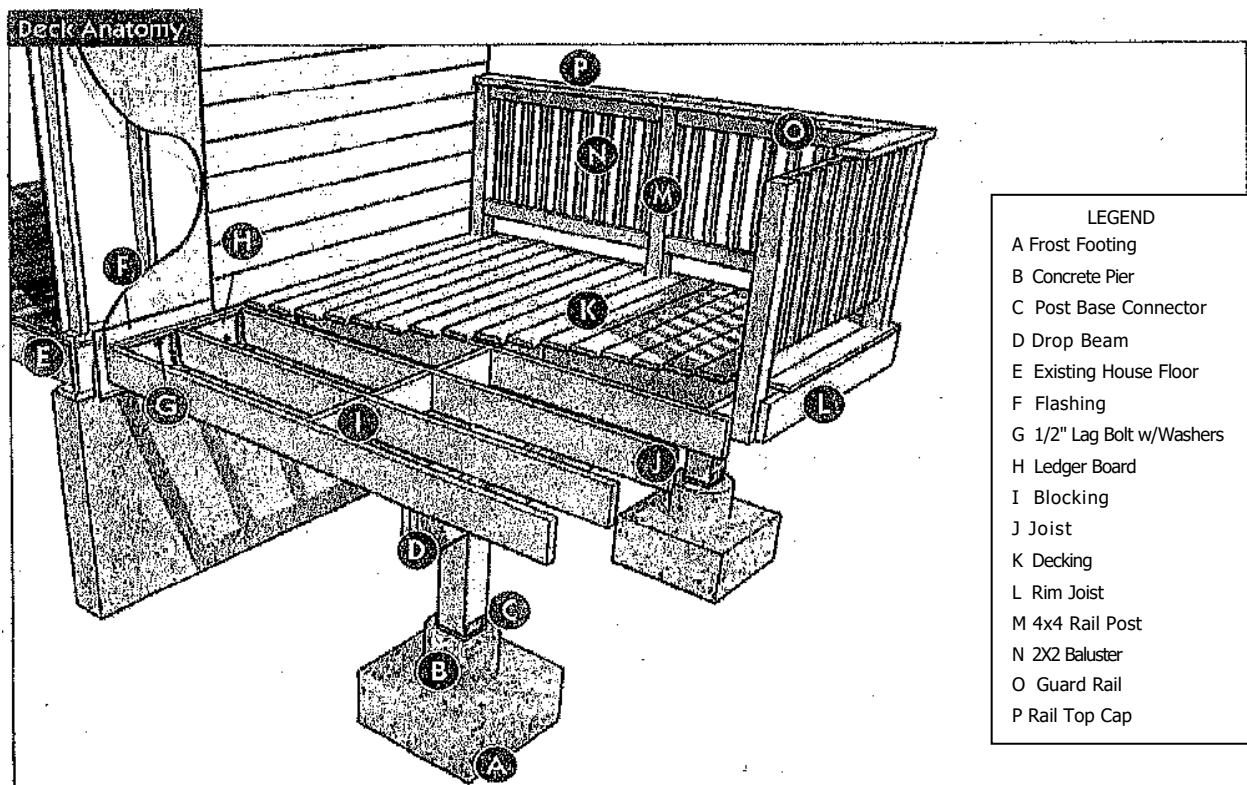

**FOOTING SIZE (In Inches)<sup>1,2,3</sup>**

Joist Length		Post Spacing (Measured Center to Center)										
		4'	5'	6'	7'	8'	9'	10'	11'	12'	13'	14'
6'	Corner Footing	8	9	10	11	11	12	12	13	14	14	15
	Intermediate Footing	10	11	12	13	14	15	15	16	17	17	18
	Footing Thickness	6	6	6	6	6	6	6	6	6	6	8
7'	Corner Footing	9	10	13	11	12	13	13	14	15	15	16
	Intermediate Footing	11	12	13	14	15	16	17	17	18	19	19
	Footing Thickness	6	6	6	6	6	6	6	6	8	8	8
8'	Corner Footing	10	10	11	12	13	14	14	15	15	16	17
	Intermediate Footing	12	13	14	15	16	17	18	19	19	20	21
	Footing Thickness	6	6	6	6	6	6	8	8	8	8	8
9'	Corner Footing	10	11	12	13	14	14	15	16	16	17	18
	Intermediate Footing	12	14	15	16	17	18	19	20	20	21	22
	Footing Thickness	6	6	6	6	6	8	8	8	8	8	8
10'	Corner Footing	10	12	12	13	14	15	16	16	17	18	18
	Intermediate Footing	13	14	15	17	18	19	20	21	21	22	23
	Footing Thickness	6	6	6	6	8	8	8	8	8	8	10
11'	Corner Footing	11	12	13	14	15	16	16	17	18	19	19
	Intermediate Footing	13	15	16	17	19	20	21	22	22	23	24
	Footing Thickness	6	6	6	6	8	8	8	8	8	10	10
12'	Corner Footing	11	12	14	15	15	16	17	18	19	19	20
	Intermediate Footing	14	15	17	18	19	20	21	22	23	24	25
	Footing Thickness	6	6	6	8	8	8	8	8	10	10	10
13'	Corner Footing	12	13	14	15	16	17	18	19	19	20	21
	Intermediate Footing	14	16	17	19	20	21	22	23	24	25	26
	Footing Thickness	6	6	6	8	8	8	8	10	10	10	10
14'	Corner Footing	12	13	15	16	17	18	18	19	20	21	22
	Intermediate Footing	15	17	18	19	21	22	23	24	25	26	27
	Footing Thickness	6	6	8	8	8	8	10	10	10	10	10
15'	Corner Footing	12	14	15	16	17	18	19	20	21	22	22
	Intermediate Footing	15	17	19	20	21	23	24	25	26	27	28
	Footing Thickness	6	6	8	8	8	10	10	10	10	10	12
16'	Corner Footing	13	14	15	17	18	19	20	20	21	22	23
	Intermediate Footing	16	18	19	21	22	23	25	26	27	28	29
	Footing Thickness	6	8	8	8	8	10	10	10	10	12	12

<sup>1</sup> All footing sizes are base diameters<sup>2</sup>.

<sup>2</sup> For square footings, insert the diameter (d) into the following formula:  $\sqrt{((d/2)^2 \times \pi)}$ . This number will give you the square dimension and must be rounded up to the nearest inch.

<sup>3</sup> Joist length is the joist span plus any overhang beyond the beam.

**FOOTINGS**

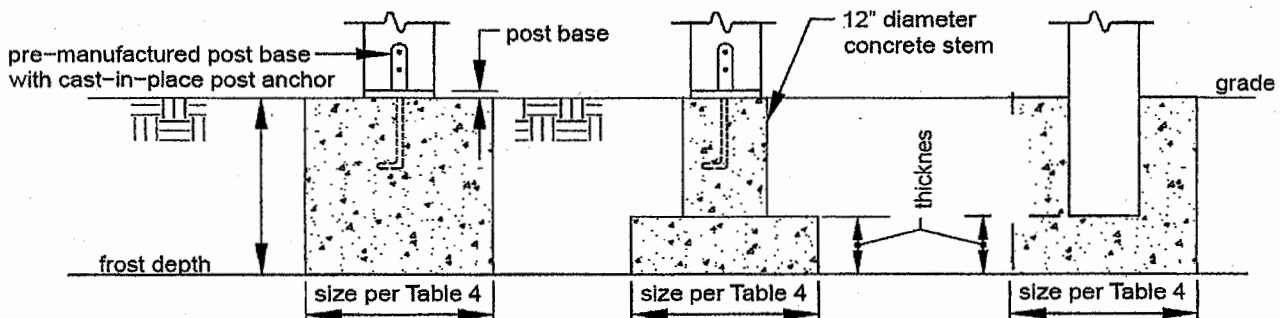

## JOIST-TO-BEAM CONNECTIONS

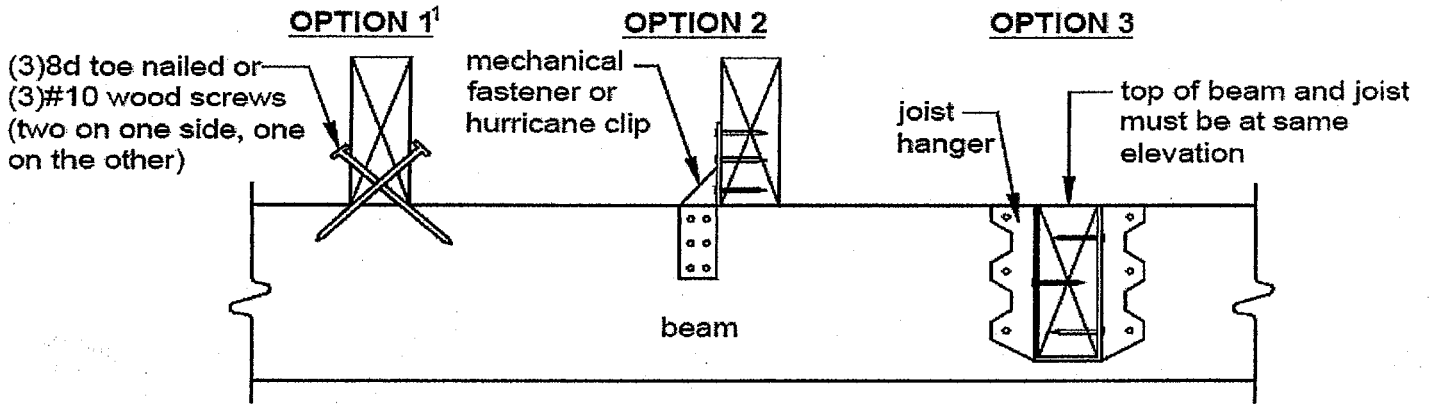

<sup>1</sup>Option 1 is not allowed on free-standing decks.

## LEDGER ATTACHMENTS

Ledger boards must be attached to the existing house in accordance with all of the following and section 9. Compliance is critical to ensure the safety and structural stability of your deck.

- 1 The ledger board depth must be greater than or equal to the depth of the deck joists, but not less than a 2"x8". The ledger board must be attached in accordance with one of the conditions shown in following 3 figures, except if metal plate connected wood floor trusses were used in the house.
- 2 The existing band board on the house must be capable of supporting the deck. If this cannot be verified or if existing conditions differ from the details here, then a free standing deck or an engineered design is required.
- 3 The top of the ledger board and the top of the deck joists must be at the same elevation.

**Flashing:** All connections between deck and dwelling shall be weatherproof. Any cuts in exterior finish shall be flashed. Exterior finish, such as siding, must be removed in the area of the ledger board prior to installation of ledger board. **SPS 321.24(3)**

**Flashing Material:** Must be corrosion resistant with a minimum thickness of 0.019.

## ATTACHMENT OF LEDGER BOARD TO BAND BOARD OR BAND JOIST

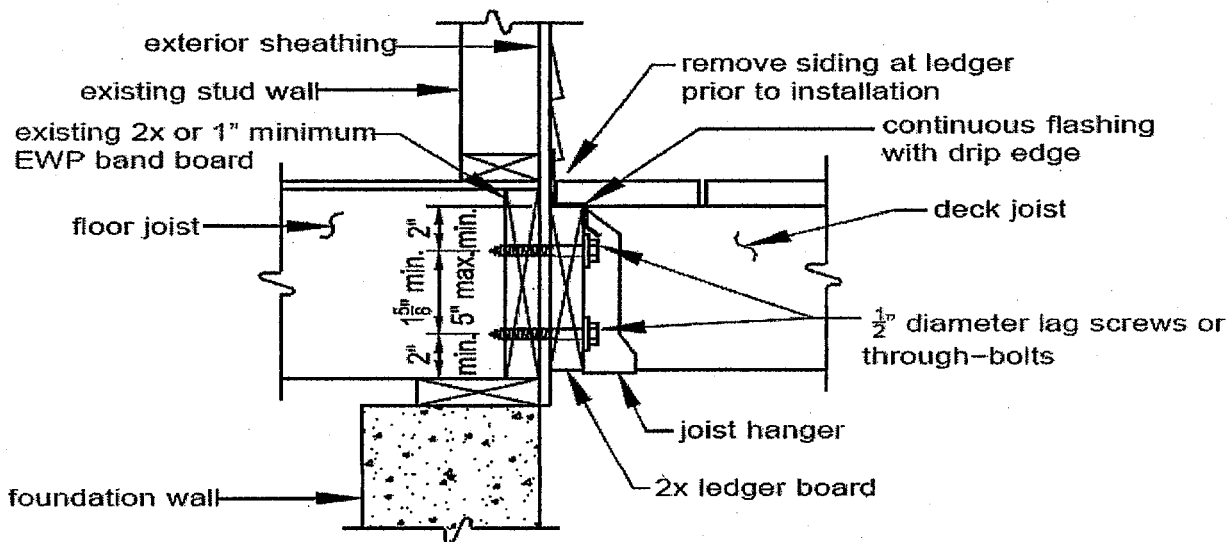

**Wood I joists:** If the minimum 1" EWP or 2x band board is not present, a free standing deck is required.

**Prohibited Ledger Attachments:** Through an exterior veneer such as brick, stone, or to or through a masonry chimney

**MAXIMUM BEAM SPAN LENGTH FOR SOUTHERN PINE<sup>1</sup>**

Joist Span	(Number of Plies)				Beam Size <sup>2</sup> – Inches			
	(2) 2x6	(2) 2x8	(2) 2x10	(2) 2x12	(3) 2x6	(3) 2x8	(3) 2x10	(3) 2x12
≤ 6'	6'-11"	8'-9"	10'-4"	12'-2"	8'-2"	10'-10"	13'-0"	15'-3"
≤ 8'	5'-11"	7'-7"	9'-0"	10'-7"	7'-5"	9'-6"	11'-3"	13'-3"
≤ 10'	5'-4"	6'-9"	8'-0"	9'-5"	6'-8"	8'-6"	10'-0"	11'-10"
≤ 12'	4'-10"	6'-2"	7'-4"	8'-7"	6'-1"	7'-9"	9'-2"	10'-9"
≤ 14'	4'-6"	5'-9"	6'-9"	8'-0"	5'-8"	7'-2"	8'-6"	10'-0"
≤ 16'	4'-3"	5'-4"	6'-4"	7'-6"	5'-3"	6'-8"	7'-11"	9'-4"
≤ 18'	4'-0"	5'-0"	6'-0"	7'-0"	5'-0"	6'-4"	7'-6"	8'-10"

**MAXIMUM JOIST-SPAN LENGTH<sup>1</sup>**

Joist Spacing (on center)	Joist Size	Douglas Fir/Larch, Hem/Fir, SPF <sup>2</sup>		Southern Pine	
		Without Overhang	With Overhangs	Without Overhang	With Overhangs
12"	2"x6"	9'-1"	8'-1"	9'-6"	8'-7"
	2"x8"	12'-6"	9'-5"	13'-1"	10'-1"
	2"x10"	15'-8"	13'-7"	16'-2"	14'-6"
	2"x12"	18'-0"	18'-0"	18'-0"	18'-0"
16"	2"x6"	8'-3"	8'-0"	8'-7"	8'-7"
	2"x8"	11'-1"	9'-5"	11'-10"	10'-1"
	2"x10"	13'-7"	13'-7"	14'-0"	14'-0"
	2"x12"	15'-9"	15'-9"	16'-6"	16'-6"
24"	2"x6"	6'-9"	6'-9"	7'-6"	7'-6"
	2"x8"	9'-1"	9'-1"	9'-8"	9'-8"
	2"x10"	11'-1"	11'-1"	11'-5"	11'-5"
	2"x12"	12'-10"	12'-10"	13'-6"	13'-6"

<sup>1</sup> Spans are based on 40 psf live load, 10 psf dead load, normal loading duration, wet service conditions, and deflections of  $\Delta=L/360$  for main span and  $L/180$  for overhang with a 220 lb. point load.

<sup>2</sup> Beam depth must be equal to or greater than joist depth if joist hangers are used

<sup>3</sup> Incising is assumed.

<sup>4</sup> Design values based on northern species with no incising assumed.

**Beam Span Length:** Is measured from center of adjacent posts and does not include overhang.

**Beam Cantilevers:** Maximum length is equal to ¼ of the actual beam span length. (0.25 x beam span)

**Joists Span:** Is measured between the centerline of bearing at each joist span end and does not include the overhangs.

**Joist Length:** Is Joist span plus overhang.

**Joist Cantilever:** May overhang past the center of the beam up to ¼ of the actual joist span.

**Bridging or Solid Blocking:** Shall be provided for 2x10 and greater at intervals not exceeding 8'. Must be attached with three 10d toe nails at each end. **SPS 321.22(9)**

**Framing Details:** Header beams longer than 6' and floor joists longer than 8' framed into beams shall be supported by joist hangers or framing anchors. Floor joists may be supported on ledger strips of at least 2" by 2" nominal. **SPS 321.22(7)**

## ATTACHMENT OF LEDGER BOARD TO SOLID FOUNDATION

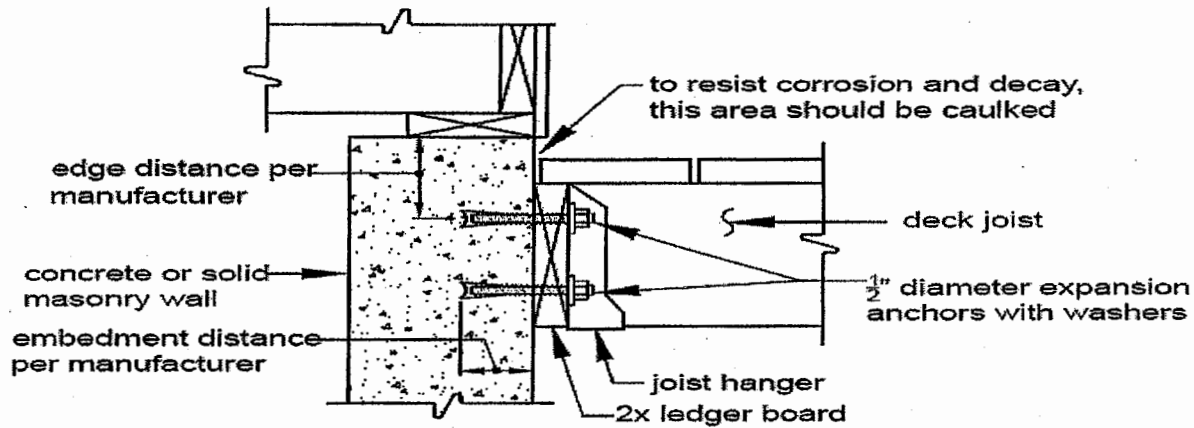

## ATTACHMENT OF LEDGER BOARD TO HOLLOW FOUNDATION

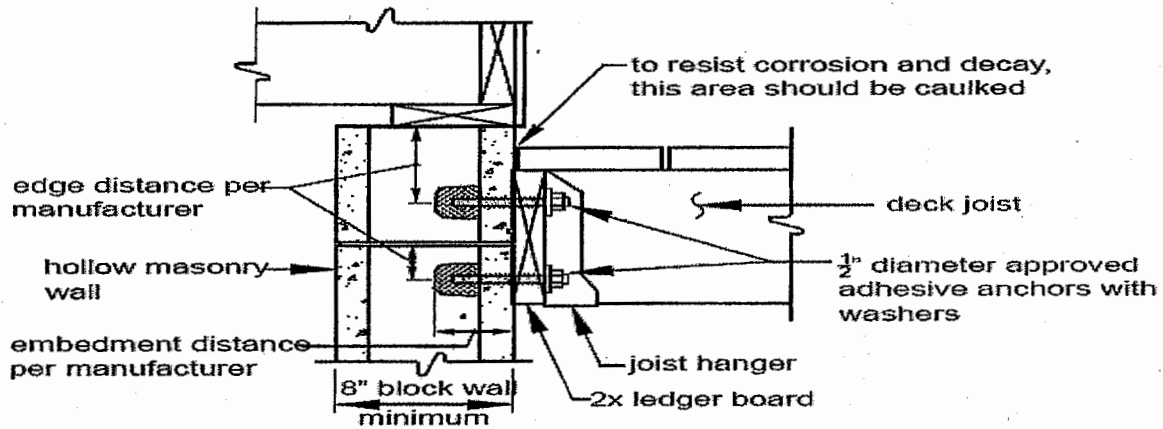

**LEDGER BOARD FASTENER SPACING, ON CENTER** <sup>1,2,3</sup>

Fastener	Band Board	Joist Span: less than or equal to						
		6'	8'	10'	12'	14'	16'	18'
Lag screws	1" EWP	24"	18"	14"	12"	10"	9"	8"
	1 1/8" EWP	28"	21"	16"	14"	12"	10"	9"
	2x Lumber	30"	23"	18"	15"	13"	11"	10"
Through Bolts	1" EWP	24"	18"	14"	12"	10"	9"	8"
	1 1/8" EWP	28"	21"	16"	14"	12"	10"	9"
	2x Lumber	36"	36"	34"	29"	24"	21"	19"
Through Bolts with 1/2" stacked washers <sup>4,5</sup>	2x Lumber	36"	36"	29"	24"	21"	18"	16"
Adhesive anchors		32"	32"	32"	24"	24"	16"	16"

- <sup>1</sup> These values are valid for deck ledgers consisting of douglas fir/larch, hem/fir, or southern pine; and for band boards consisting of douglas fir/larch, hem/fir, spruce/pine/fir, southern pine, or engineered wood product (EWP).
- <sup>2</sup> Where solid sawn pressure preservative treated deck ledgers are attached to engineered wood products (minimum 1" thick wood structural panel band joist or structural composite lumber including laminated veneer lumber), the ledger attachment must be designed in accordance with accepted engineering practice. These tabulated values are based on 300 lbs and 350 lbs for 1" and 1 1/8" EWP rim board, respectively.
- <sup>3</sup> The thickness of the sheathing over the band board must not exceed 15/32".
- <sup>4</sup> The maximum gap between the face of the ledger board and face of the wall sheathing is 1/2".
- <sup>5</sup> Wood structural panel sheathing, gypsum board sheathing, or foam sheathing is permitted between the ledger board and the band board. Stacked washers are permitted in combination with wood structural panel sheathing, but are not permitted in combination with gypsum board or foam sheathing. The maximum distance between the face of the ledger board and the face of the band board is 1".

**Diagonal Bracing:** Provide diagonal bracing both parallel and perpendicular to the beam at each post as shown in Figure below for decks over 24 inches from grade.

**Parallel to the beam:** The bracing must be bolted to the post at one end and to the beam at the other.

**Perpendicular to the beam:** The bracing must be bolted to the post at one end and to a joist or blocking between joists at the other.

**For joists that do not align with the bracing location:** provide blocking between the adjacent joists.

### DIAGONAL BRACING REQUIREMENTS

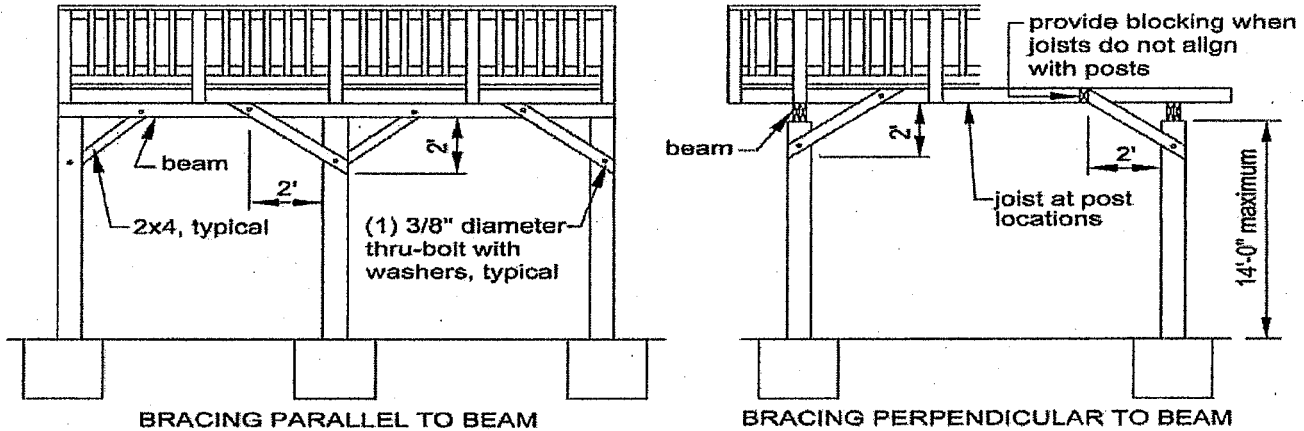

**Tension tie requirements:** Tension ties can be used in place of perpendicular bracing, but are not allowed on free standing decks. At least 4 ties must be installed, at the end joist and first inside joist at each end of the deck as shown in Figure below. A set of tension-ties must be installed for each structurally independent section of a multi level deck.

### TENSION-TIE CONNECTION, WITH LEDGER BOARD

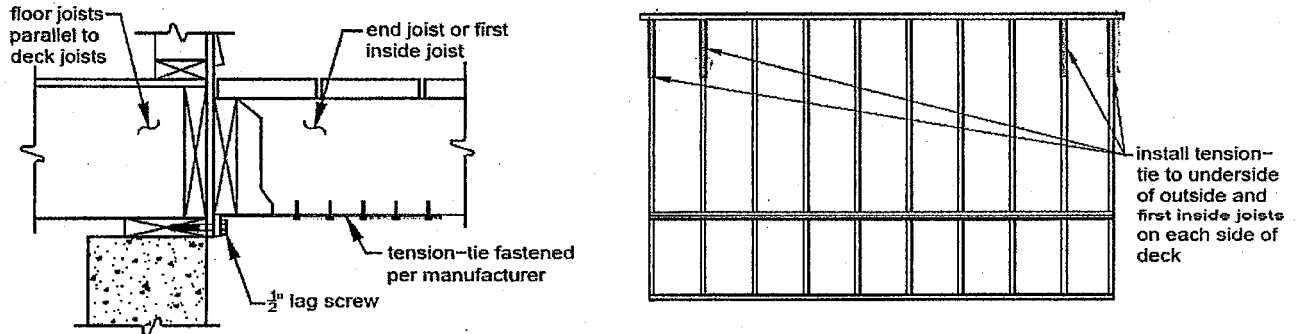

### HOLD-DOWN TENSION DEVICE, WITH LEDGER BOARD

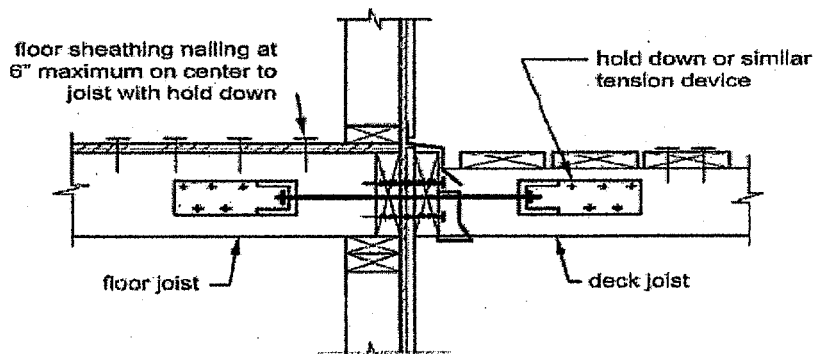

**Hold down tension devices:** If used instead of perpendicular bracing as described above, must be provided in at least 2 locations per deck. Each device must have an allowable stress design capacity of at least 1,500 pounds.

# ATTACHMENT OF FREE-STANDING DECK TO HOUSE FOR LATERAL SUPPORT

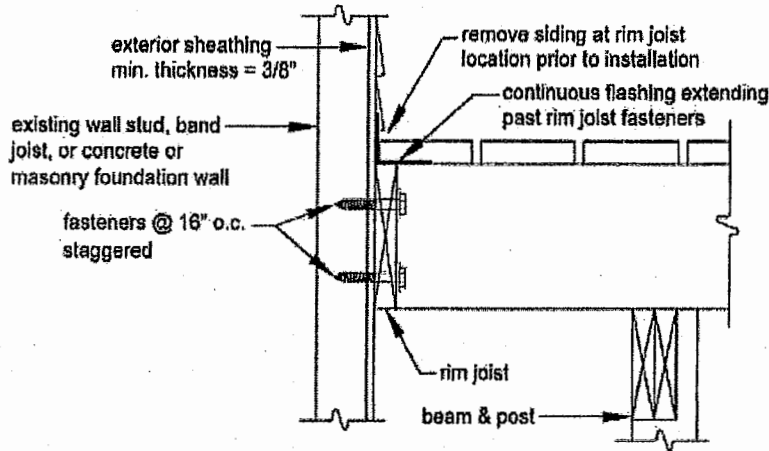

## GUARD AND POSTS

All open sides of a deck area that is more than 24 inches above grade at any point within 36 inches beyond the edge of the deck, must have a guard that complies with the figure below, and with all of the following:

- 1 Required horizontal guards shall not have openings from the walking surface to the required guard height which allow passage of a sphere 4 inches in diameter when applying a force of 4 pounds.
- 2 Required guards at stairs shall not have openings which allow passage of a sphere 4 3/8 inches in diameter when applying a force of 4 pounds. The triangle opening formed by the riser, tread, and bottom rail of a guard shall not allow passage of a 6 inch sphere when applying a force of 4 pounds.
- 3 Wet lumber must be spaced such that when shrinkage due to drying occurs the opening is remains compliant.
- 4 Rope, cable, or a similar non rigid material may be used instead of balusters. Must be strung with maximum openings of 3 1/2 inches and with vertical supports no more than 4 feet apart.
- 5 The guard and posts must withstand a 200 pound load applied in any direction.
- 6 Guard infill components, such as balusters and panel fillers, must withstand a horizontally applied perpendicular load of 50 pounds on any one foot square area.
- 7 Wood/plastic composites of equivalent dimensions may be substituted for the guard cap and infill elements shown in the figure below if the manufacturer's instructions permit this use.

## GUARDS

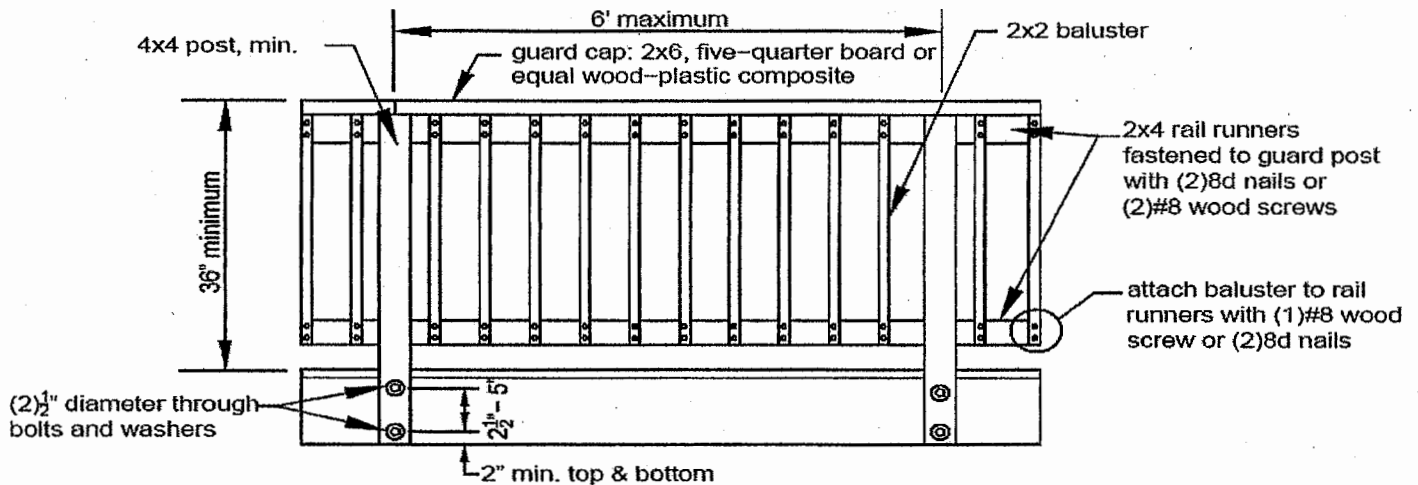

## SECTION 3: POSTS AND POST-TO-BEAM CONNECTIONS

Posts must comply with all of the following:

1. The post height, measured from the top of the footing to the underside of the beam, must be in accordance with Table 2.

**Table 2**  
**MAXIMUM POST HEIGHT**

Post Size	Maximum Height
4"x4"	6'
4"x6"	8'
6"x6"	14'

2. Any post supporting a beam splice must be a minimum of 6"x6".
3. Beams must be attached to posts by the appropriate methods shown in Figure 2. Toe-nailing of beams to posts is prohibited.
4. Post caps, as shown in Figure 2, must be specifically designed for 2- or 3-ply beams and the post size used. Attachment must be in accordance with the manufacturer's instructions.
5. It is recommended that cut-ends of posts should be field-treated with a wood preservative. These preservatives can be found in the paint department of most hardware or home-center stores.

**Figure 2**

### POST-TO-BEAM CONNECTIONS

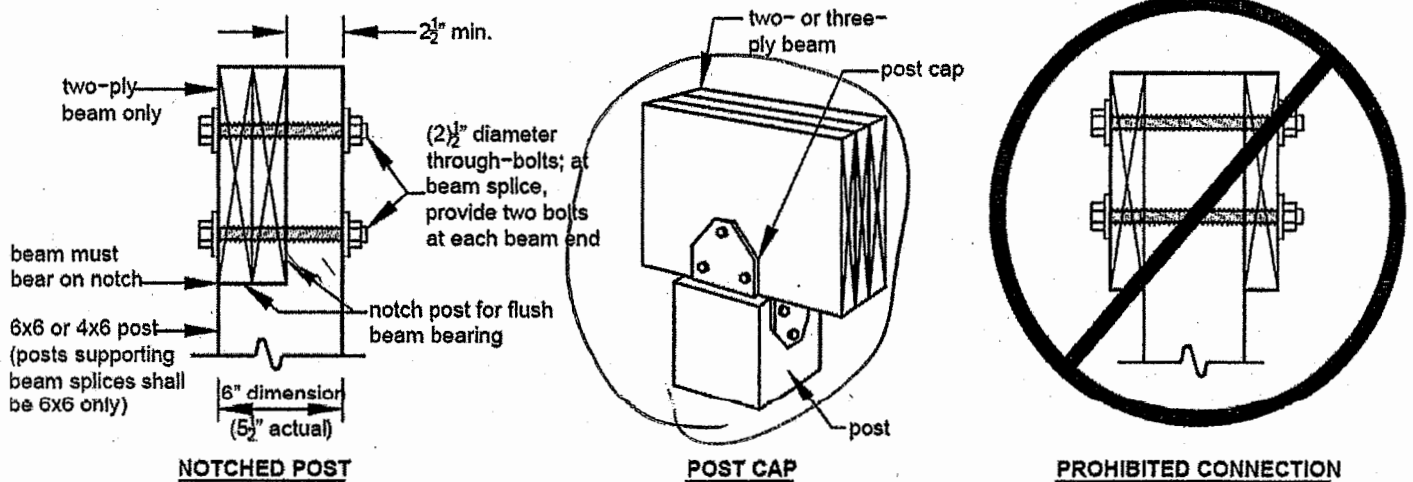

### MAXIMUM BEAM SPAN LENGTH<sup>1</sup> FOR DOUGLAS FIR/LARCH<sup>3</sup>, HEM/FIR<sup>3</sup>, SPRUCE/PINE/FIR (SPF)<sup>3</sup>, WESTERN CEDAR, PONDEROSA PINE<sup>4</sup>, AND RED PINE<sup>4</sup>

Joist Span	(Number of Plies)						Beam size - Inches					
	3x6 (2)2x6	3x8 (2)2x8	3x10 (2)2x10	3x12 (2)2x12	4x6	4x8	4x10	4x12	(3)2x6	(3)2x8	(3)2x10	(3)2x12
≤ 6'	5'-5"	6'-10"	8'-4"	9'-8"	6'-5"	8'-5"	9'-11"	11'-5"	7'-4"	9'-8"	12'-0"	13'-11"
≤ 8'	4'-8"	5'-11"	7'-3"	8'-5"	5'-6"	7'-3"	8'-7"	9'-11"	6'-8"	8'-6"	10'-5"	12'-1"
≤ 10'	4'-2"	5'-4"	6'-6"	7'-6"	4'-11"	6'-6"	7'-8"	8'-10"	6'-0"	7'-7"	9'-4"	10'-9"
≤ 12'	3'-10"	4'-10"	5'-11"	6'-10"	4'-6"	5'-11"	7'-0"	8'-1"	5'-6"	6'-11"	8'-6"	9'-10"
≤ 14'	3'-6"	4'-6"	5'-6"	6'-4"	4'-2"	5'-6"	6'-6"	7'-6"	5'-1"	6'-5"	7'-10"	9'-1"
≤ 16'	3'-1"	4'-1"	5'-1"	5'-11"	3'-11"	5'-2"	6'-1"	7'-0"	4'-9"	6'-0"	7'-4"	8'-6"
≤ 18'	2'-9"	3'-8"	4'-8"	5'-7"	3'-8"	4'-10"	5'-8"	6'-7"	4'-6"	5'-8"	6'-11"	8'-1"

**Stairs:** Minimum width is 36" SPS 321.04(2)(a). Maximum rise is 8" SPS 321.04(2)(b). Minimum tread depth is 9" SPS 321.04(2)(c). The greatest tread depth may not exceed the smallest tread depth by more than 3/8" throughout run. The greatest riser height may not exceed the smallest riser height by more than 3/8" throughout run SPS 321.04(2)(e). Stairways with open risers shall be constructed to prevent the through passage of a sphere with a diameter of 4 inches or larger between any two adjacent treads SPS 321.04(2)(f).

**Ramps:** Slope shall not exceed 1 foot of rise in 8 feet of run SPS 321.045.

**Stair stringers:** Stringers must comply with all of the following:

- 1 Stringers must be sawn or solid 2"x12"s complying with the above tread and riser dimensions.
- 2 Cut stringers must be spaced no more than 18 inches on center.
- 3 Stringers must bear on a solid surface (minimum of 3 1/2 inches thick and 8 inches in diameter) and attach to the deck or a landing in accordance with figure below. Prior to placement of solid surface, all loose or organic material shall be removed.
- 4 Stringer span length is measured using the horizontally projected distance between the centerlines of bearing at each end.
- 5 The span length of a cut stringer must not exceed 6 feet, and the throat size of cut stringers must not be less than 5 inches. Shown in stringer span length figure.

### STRINGER BEARING

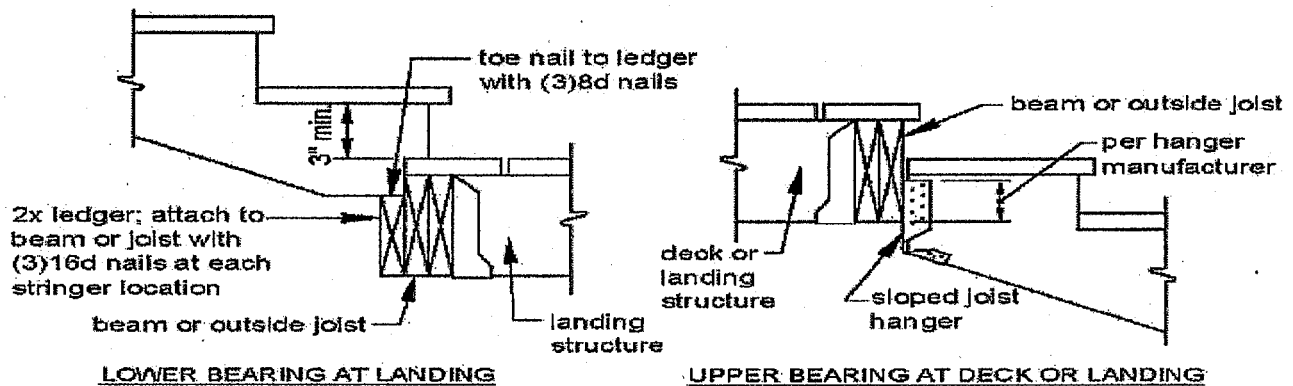

**Solid stringer exception:** Stringers for a stairway that has a width of 36 inches may have a horizontally projected span of up to 13 feet 3 inches if the stairway is framed solely with 2 solid stringers.

**Intermediate supported stringers:** If the total stringer length exceeds the above dimensions, a 4"x4" post may be provided to support the stringer and shorten its span length. The 4"x4" post must be notched and bolted to the stringer in accordance with post beam connection figure. The post must bear over the middle 1/3 of a footing that is constructed in accordance with Figure 29 and must be attached as shown in post beam connection figure. An intermediate landing as described above may also be provided to shorten the stringer span.

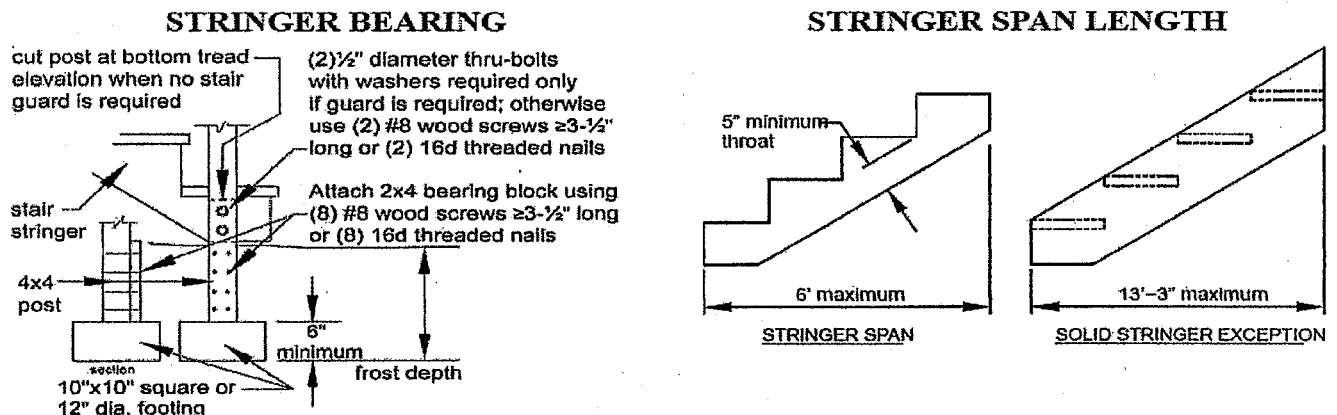

## STAIRWAY TREADS

Attachment per tread at each stringer or ledger:  
 2x\_ or 5/4 treads - (2)#8 threaded nails or (2)#8 screws  $\geq 2\text{-}1/2"$  long  
 3x\_ treads - (2)#16d threaded nails or (2)#8 screws  $\geq 3\text{-}1/2"$  long

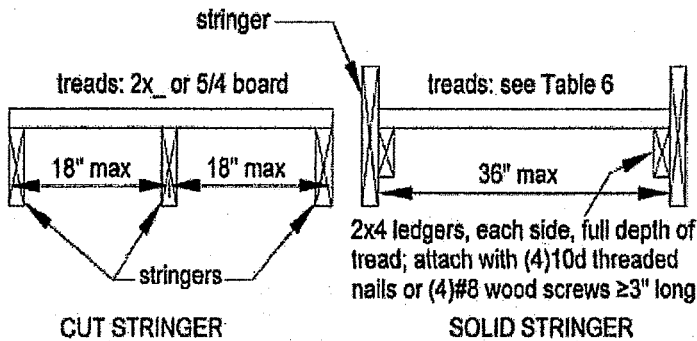

## MINIMUM TREAD SIZES<sup>1</sup>

Species	Cut Stringer	Solid Stringer
Douglas Fir/ Larch, Hem/ Fir, SPF <sup>2</sup>	2x4 or 5/4	2x8 or 3x4
Southern Pine	2x4 or 5/4	2x8
Redwood, West- ern Cedars, Pon- derosa Pine <sup>3</sup> , Red Pine <sup>3</sup>	2x4 or 5/4	2x10 or 3x4

<sup>1</sup> Assumes 300 lb concentrated load, L/288 deflection limit, No. 2 grade, and wet service conditions.

<sup>2</sup> Incising assumed for refractory species including Douglas fir-larch, hem-fir, and spruce-pine-fir.

<sup>3</sup> Design values based on northern species with no incising assumed.

## STAIR GUARDS

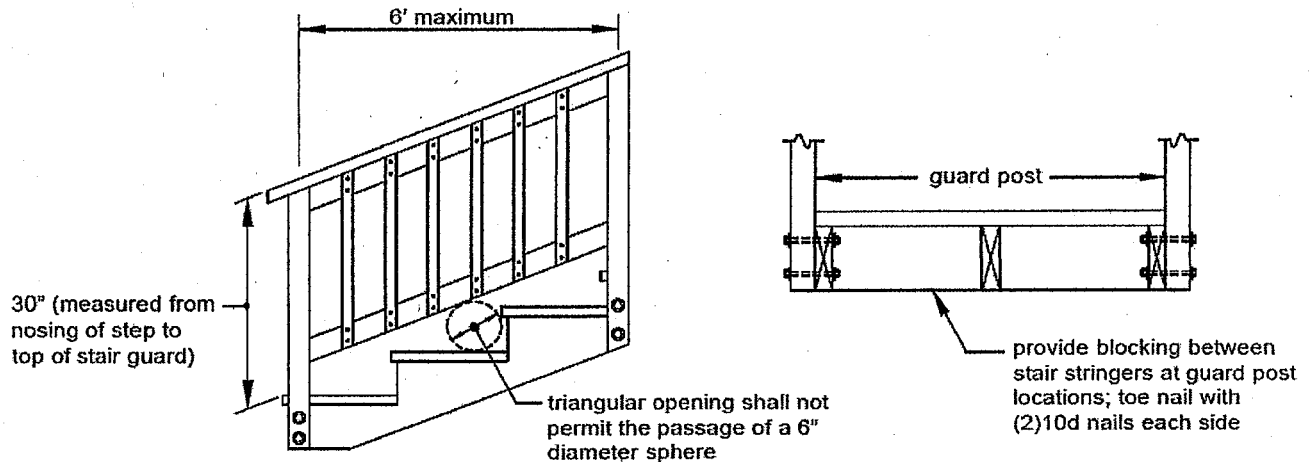

**Handrails:** Stair of more than 3 risers must have at least one handrail for the full length of the stair. **SPS 321.04(3)**  
 Top of the handrail shall be at least 30" but not more than 38" above the nosing of the treads. **SPS 321.04(3)(b)**  
 Handrail size and configuration shall follow code. **SPS 321.04(3)(b)5**

# HANDRAIL SHAPES

## ROUND

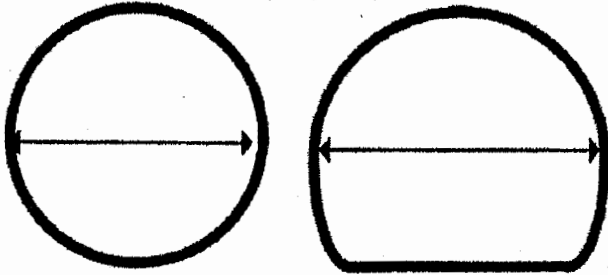

**MAXIMUM 2"  
DIAMETER**

## RECTANGULAR

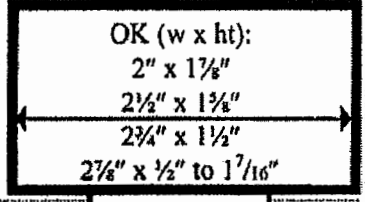
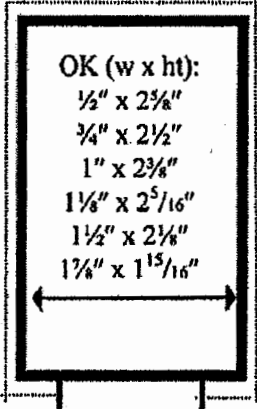

**MAXIMUM 2 $\frac{7}{8}$ "  
CROSS SECTION**

Maximum  $6\frac{1}{4}$ "  
gripping surface  
including  
minimum  $\frac{1}{4}$ " recess  
on each side

## OTHERS



**INSPECTIONS NEEDED:**

Construction Inspection required:

- Footings need to be inspected before backfilling post or placement of concrete
- Prior to decking and after if deck is less than 2 feet from grade.
- After completion if deck is more than 2 feet from grade.

**FRAMING PLAN**

A typical framing plan shows a bird's eye or plan view of the joist and beam layout. Location of the ledger board, diagonal bracing or hold down devices, posts, and footings. The type, size, and spacing of the ledger board fasteners. You can use the sample typical deck framing plan shown on the next page in combination with the requirements in this document to complete your deck.