



# TOWN OF CHESHIRE

80 CHURCH STREET | CHESHIRE, MASSACHUSETTS 01225

WWW.CHESHIRE-MA.GOV

## OFFICE OF THE HARBORMASTER

|                     |  |
|---------------------|--|
| Applicant Name      | Phone Number(s)                                |
| Home Street Address | City, State, Zip Code *                        |
| Lake Street Address | City, State, Zip Code *                        |
| Boat Description    | Boat Registration Number (example IA- 1234-AB) |

Are you the contact person for this dock? (circle one) Yes/ No

If you are not the contact person, please list their name and phone number here:

Is this application for (check one)

- Renewal of existing -Dock Site Name/ Number - \_\_\_\_\_
- New Permit
- Change of existing permit- Dock Site Number/ Name of Present Permittee: \_\_\_\_\_

SKETCH OF PROPOSED DOCK AND DIMENSIONS. Shade in the correct configuration of your dock and fill in the proper dimensions (A-E listed below). Incomplete applications will be returned to applicants.

- A. \_\_\_\_\_ Width of "L" or "T" portion.
- B. \_\_\_\_\_ Width of main dock.
- C. \_\_\_\_\_ Total length of "L" or "T" portion.
- D. \_\_\_\_\_ "Dimension D" length - length of dock from shore to point where water reaches 3ft in depth. (only necessary if dock is more than 50ft in total length).
- E. \_\_\_\_\_ Total length of dock.
- F. \_\_\_\_\_ Number of hoists/lifts adjacent to dock.

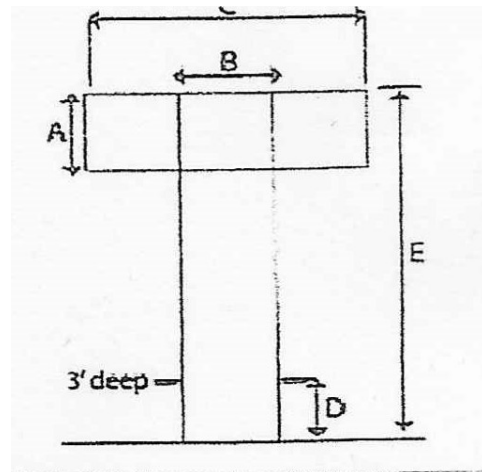

DO NOT USE - FOR OFFICIAL USE ONLY

Date Site Visited \_\_\_\_\_

Date Site Approved \_\_\_\_\_

Company Installing \_\_\_\_\_

Yearly hoist/slip fee \_\_\_\_\_

Total Fee collected \_\_\_\_\_

Applications approved by: \_\_\_\_\_

Dock Management Local Harbormaster

Name: \_\_\_\_\_

Signature: \_\_\_\_\_