

# SCRIPTURE CARDS

TO BE ABLE TO HAVE LOVE, JOY, PEACE, PATIENCE, KINDNESS, GOODNESS, FAITHFULNESS, GENTLENESS AND SELF-CONTROL, WE NEED THE HOLY SPIRIT!  
WHEN WE LIVE BY THE HOLY SPIRIT, THESE THINGS WILL BE PRODUCED IN OUR LIVES!

COLOUR IN YOUR VERY OWN BORN TO BE JOYFUL SCRIPTURE CARDS WITH YOUR FAVOURITE COLOURS AND PATTERNS. CUT THEM OUT AND USE THEM TO DECLARE THE WORD OF GOD OVER YOUR LIFE. YOU CAN EVEN USE THEM FOR A GAME!

## GAMES:

### 1. MATCHING CARDS

- PRINT DOUBLE SIDED FOR THIS ACTIVITY. (IF YOU ARE UNABLE TO, GLUE BACK OF THE CARDS TOGETHER)
- CUT OUT AT LEAST TWO SETS OF CARDS (OR MORE IF YOU LIKE!)
- SHUFFLED THE CARDS, AND EQUALLY SHARE THEM OUT.
- MAKE SURE ALL YOUR CARDS ARE FACE DOWN SO YOU CAN'T SEE WHAT THEY ARE!
- TAKE TURNS TO PLACE A CARD FACE UP IN A PILE IN THE MIDDLE.
- IF TWO OF THE SAME CARDS END UP ON TOP OF EACH OTHER YELL SNAP!
- IF YOU ARE THE FIRST TO SHOUT 'SNAP' YOU GET TO KEEP THE PILE.
- THE PERSON WITH THE MOST CARDS AT THE END WINS.

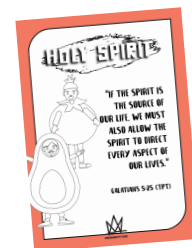
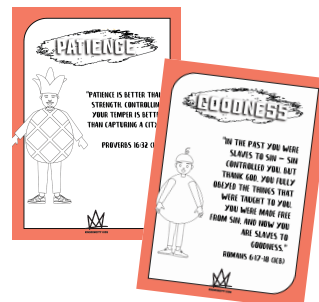

# HOLY SPIRIT

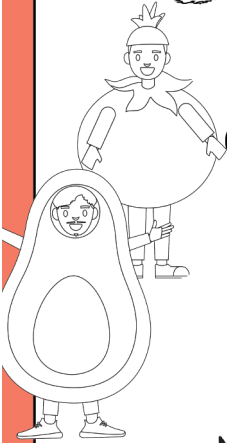

"IF THE SPIRIT IS THE SOURCE OF OUR LIFE, WE MUST ALSO ALLOW THE SPIRIT TO DIRECT EVERY ASPECT OF OUR LIVES."

GALATIANS 5:25 (TPT)



# LOVE



"LOVE YOUR NEIGHBOUR AS YOU LOVE YOURSELF."

GALATIANS 5:14 (ICB)



# JOY

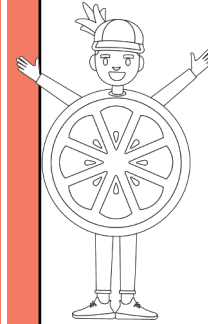

"THE JOY OF THE LORD WILL MAKE YOU STRONG."

NEHEMIAH 8:10 (ICB)



# PEACE

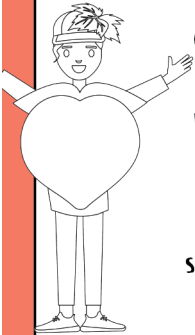

"BUT THE HELPER WILL TEACH YOU EVERYTHING. HE WILL CAUSE YOU TO REMEMBER ALL THE THINGS I TOLD YOU. THIS HELPER IS THE HOLY SPIRIT WHOM THE FATHER WILL SEND IN MY NAME."

I LEAVE YOU PEACE. MY PEACE I GIVE YOU. I DO NOT GIVE IT TO YOU AS THE WORLD DOES. SO DON'T LET YOUR HEARTS BE TROUBLED. DON'T BE AFRAID."

JOHN 14:26-27 (ICB)



# PATIENCE

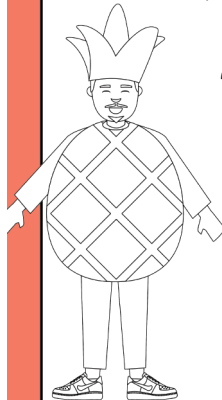

"PATIENCE IS BETTER THAN STRENGTH. CONTROLLING YOUR TEMPER IS BETTER THAN CAPTURING A CITY."

PROVERBS 16:32 (ICB)



# KINDNESS



"BUT THEN THE KINDNESS AND LOVE OF GOD OUR SAVIOUR WAS SHOWN. HE SAVED US BECAUSE OF HIS MERCY. NOT BECAUSE OF GOOD DEEDS WE DID TO BE RIGHT WITH GOD. HE SAVED US THROUGH THE WASHING THAT MADE US NEW PEOPLE. HE SAVED US BY MAKING US NEW THROUGH THE HOLY SPIRIT."

TITUS 3:4-5 (ICB)



# GOODNESS

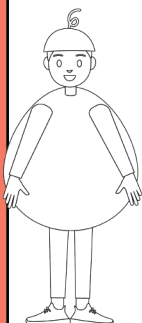

"IN THE PAST YOU WERE SLAVES TO SIN – SIN CONTROLLED YOU. BUT THANK GOD, YOU FULLY OBEYED THE THINGS THAT WERE TAUGHT TO YOU. YOU WERE MADE FREE FROM SIN, AND NOW YOU ARE SLAVES TO GOODNESS."

ROMANS 6:17-18 (ICB)



# FAITHFULNESS

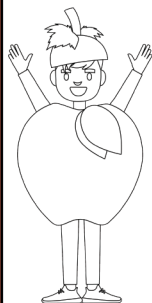

"AND JESUS WAS FAITHFUL TO GOD AS MOSES WAS. MOSES DID EVERYTHING GOD WANTED HIM TO DO IN GOD'S FAMILY."

HEBREWS 3:2 (ICB)



# GENTLENESS

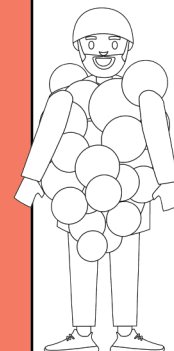

"LET ALL MEN SEE THAT YOU ARE GENTLE AND KIND. THE LORD IS COMING SOON!"

PHILIPPIANS 4:5 (ICB)



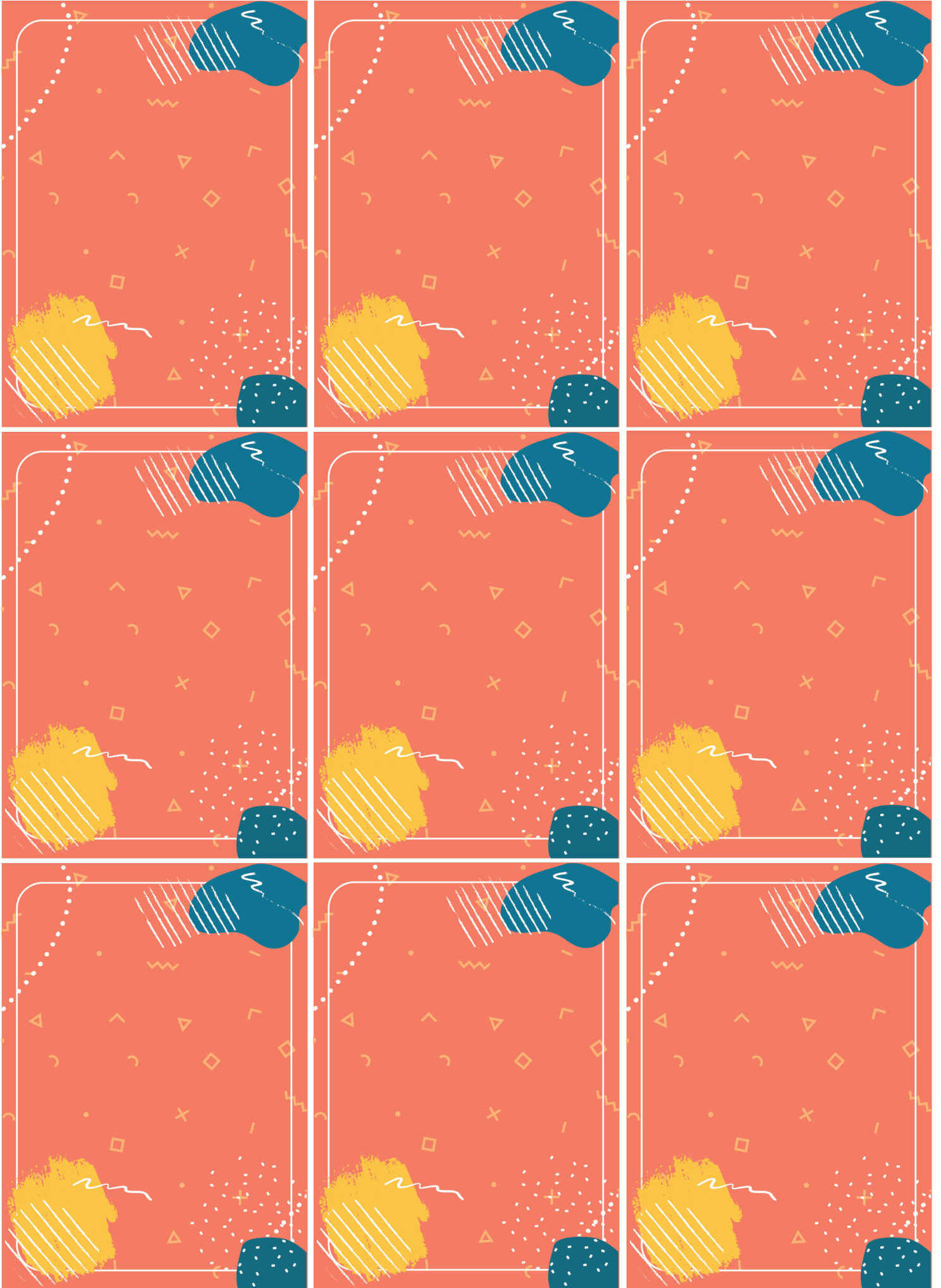

# SELF-CONTROL

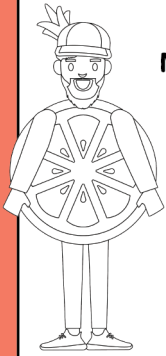

"SO PREPARE YOUR MINDS FOR SERVICE AND HAVE SELF-CONTROL. ALL YOUR HOPE SHOULD BE FOR THE GIFT OF GRACE THAT WILL BE YOURS WHEN JESUS CHRIST COMES AGAIN."

1 PETER 1:13 (ICB)



KINGDOMCITY KIDS

# THE FRUITS OF THE SPIRIT



"BUT THE SPIRIT GIVES LOVE, JOY, PEACE, PATIENCE, KINDNESS, GOODNESS, FAITHFULNESS, GENTLENESS, SELF-CONTROL. THERE IS NO LAW THAT SAYS THESE THINGS ARE WRONG."

GALATIANS 5:22-23 (ICB)



KINGDOMCITY KIDS



## HOLY SPIRIT



"IF THE SPIRIT IS THE SOURCE OF OUR LIFE, WE MUST ALSO ALLOW THE SPIRIT TO DIRECT EVERY ASPECT OF OUR LIVES."

GALATIANS 5:25 (TPT)



## LOVE



"LOVE YOUR NEIGHBOUR AS YOU LOVE YOURSELF."

GALATIANS 5:14 (ICB)



## JOY



"THE JOY OF THE LORD WILL MAKE YOU STRONG."

NEHEMIAH 8:10 (ICB)



## PEACE

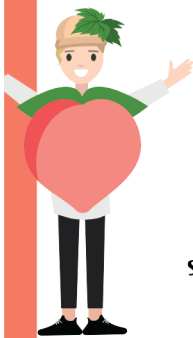

"BUT THE HELPER WILL TEACH YOU EVERYTHING. HE WILL CAUSE YOU TO REMEMBER ALL THE THINGS I TOLD YOU. THIS HELPER IS THE HOLY SPIRIT WHOM THE FATHER WILL SEND IN MY NAME."

I LEAVE YOU PEACE. MY PEACE I GIVE YOU. I DO NOT GIVE IT TO YOU AS THE WORLD DOES. SO DON'T LET YOUR HEARTS BE TROUBLED. DON'T BE AFRAID."

JOHN 14:26-27 (ICB)



## PATIENCE



"PATIENCE IS BETTER THAN STRENGTH. CONTROLLING YOUR TEMPER IS BETTER THAN CAPTURING A CITY."

PROVERBS 16:32 (ICB)



## KINDNESS



"BUT THEN THE KINDNESS AND LOVE OF GOD OUR SAVIOR WAS SHOWN. HE SAVED US BECAUSE OF HIS MERCY. NOT BECAUSE OF GOOD DEEDS WE DID TO BE RIGHT WITH GOD. HE SAVED US THROUGH THE WASHING THAT MADE US NEW PEOPLE. HE SAVED US BY MAKING US NEW THROUGH THE HOLY SPIRIT."

TITUS 3:4-5 (ICB)



## GOODNESS



"IN THE PAST YOU WERE SLAVES TO SIN – SIN CONTROLLED YOU. BUT THANK GOD, YOU FULLY OBEYED THE THINGS THAT WERE TAUGHT TO YOU. YOU WERE MADE FREE FROM SIN. AND NOW YOU ARE SLAVES TO GOODNESS"

ROMANS 6:17-18 (ICB)



## FAITHFULNESS



"AND JESUS WAS FAITHFUL TO GOD AS MOSES WAS. MOSES DID EVERYTHING GOD WANTED HIM TO DO IN GOD'S FAMILY."

HEBREWS 3:2 (ICB)



## GENTLENESS



"LET ALL MEN SEE THAT YOU ARE GENTLE AND KIND. THE LORD IS COMING SOON!"

PHILIPPIANS 4:5 (ICB)



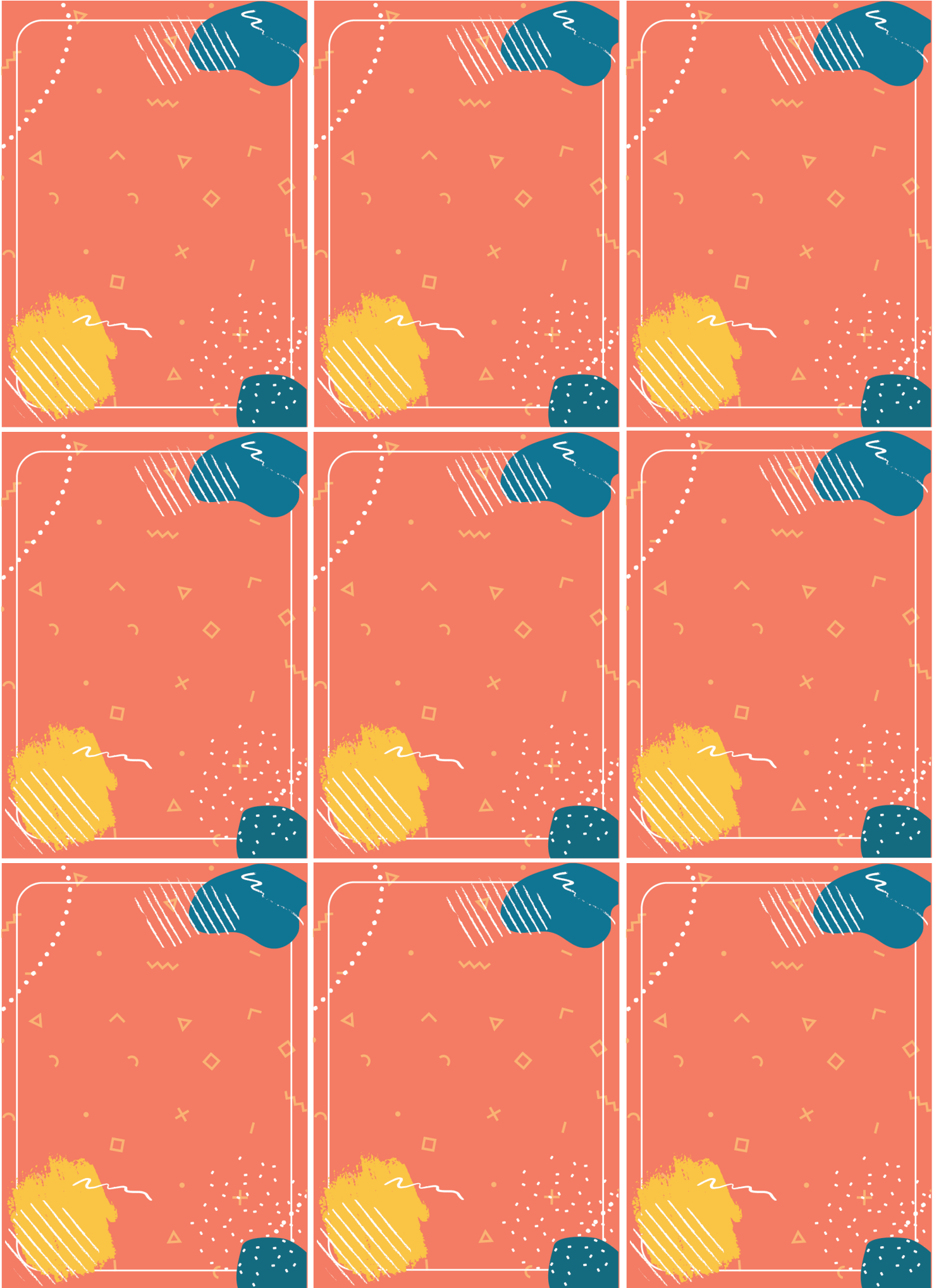

# SELF-CONTROL



"SO PREPARE YOUR MINDS FOR SERVICE AND HAVE SELF-CONTROL. ALL YOUR HOPE SHOULD BE FOR THE GIFT OF GRACE THAT WILL BE YOURS WHEN JESUS CHRIST COMES AGAIN"

1 PETER 1:13 (ICB)



KINGDOMCITY KIDS

# THE FRUITS OF THE SPIRIT



"BUT THE SPIRIT GIVES LOVE, JOY, PEACE, PATIENCE, KINDNESS, GOODNESS, FAITHFULNESS, GENTLENESS, SELF-CONTROL. THERE IS NO LAW THAT SAYS THESE THINGS ARE WRONG."

GALATIANS 5:22-23 (ICB)



KINGDOMCITY KIDS





# THE FRUIT CHALLENGE

## DIY BORN TO BE JOYFUL KITCHEN

GALATIANS 5:22-23 (ICB) SAYS "BUT THE SPIRIT GIVES LOVE, JOY, PEACE, PATIENCE, KINDNESS, GOODNESS, FAITHFULNESS, GENTLENESS, SELF-CONTROL. THERE IS NO LAW THAT SAYS THESE THINGS ARE WRONG." SPREAD THE JOY AND SHARE A STORY FROM THIS SERIES TO A FRIEND OR YOUR FAMILY USING THESE PRINTABLES.

CREATE YOUR VERY OWN BORN TO BE JOYFUL KITCHEN!

YOU WILL NEED:

- COLOUR PENCILS
- TAPE
- POPSICLE STICK/SKEWER
- CEREAL BOX

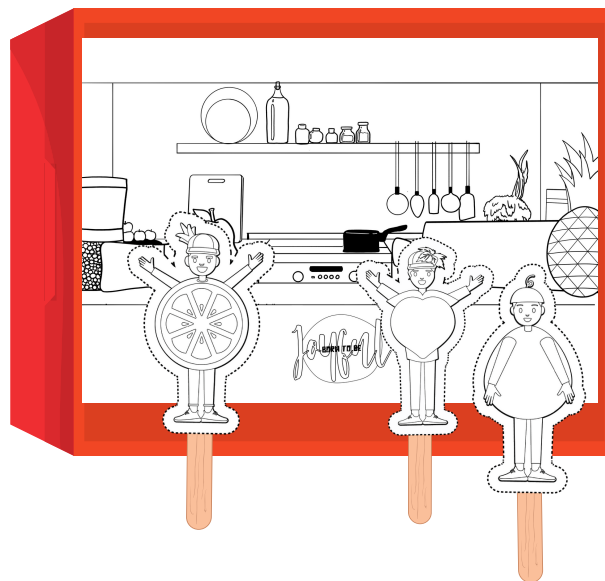

STEPS:

1. DECORATE THE CHARACTER AND BORN TO BE JOYFUL KITCHEN WITH YOUR FAVOURITE COLOURS AND PATTERNS.
2. CUT OUT THE CHARACTERS FOLLOWING THE DOTTED LINES.
3. ATTACH A POPSICLE STICK/SKEWER TO THE BACK OF EACH CHARACTER THEN SECURE WITH TAPE.
4. PASTE THE BORN TO BE JOYFUL KITCHEN TEMPLATE PROVIDED TO A CEREAL BOX FOR BETTER STABILITY.
5. USE YOUR STICK PUPPETS TO RETELL THE FRUITS OF THE SPIRIT THAT YOU'VE LEARN IN THIS SERIES TO A FRIEND OR YOUR FAMILY!

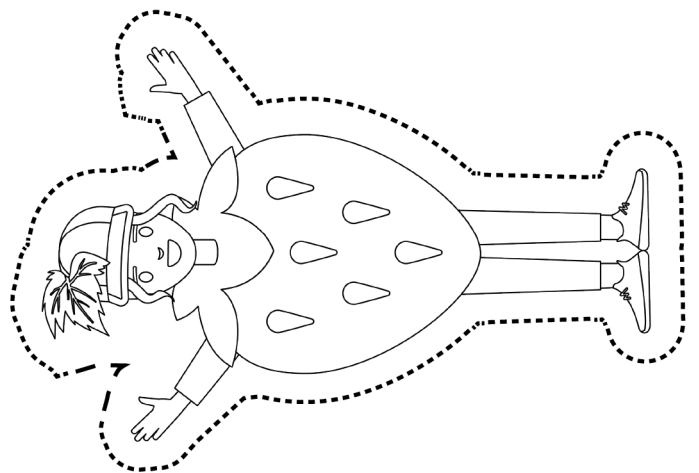
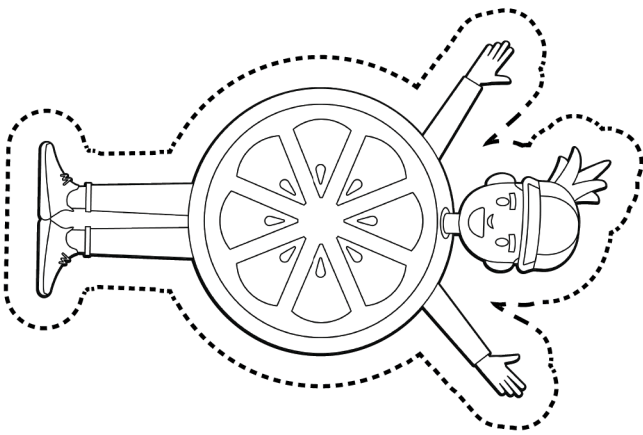
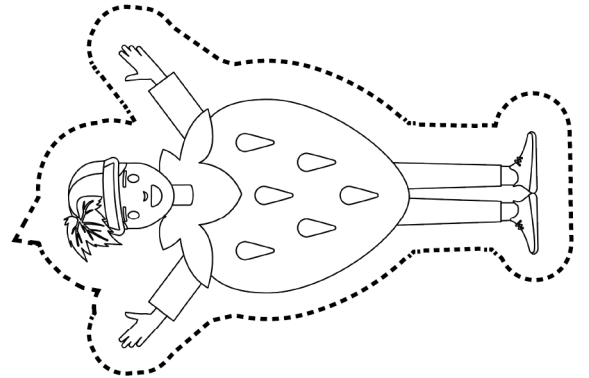
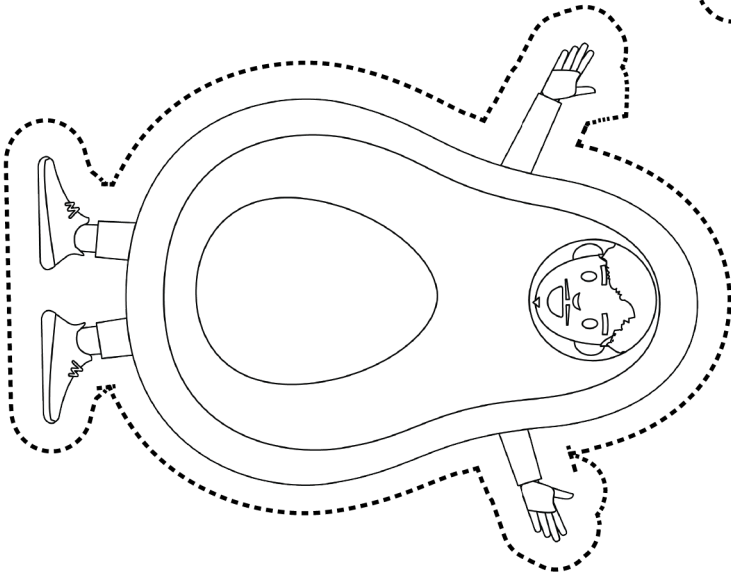
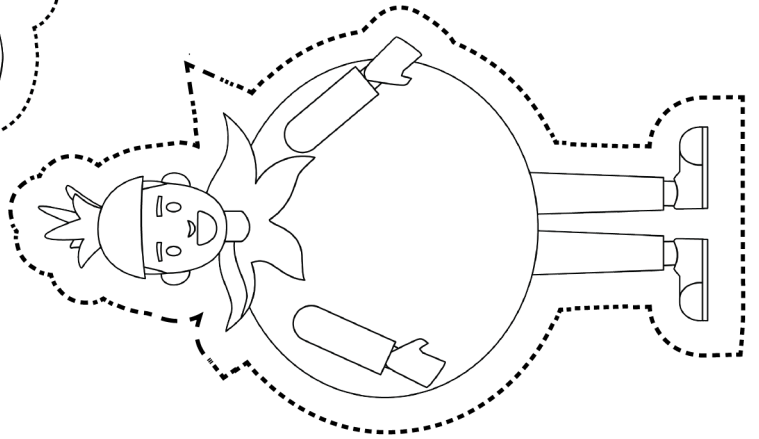
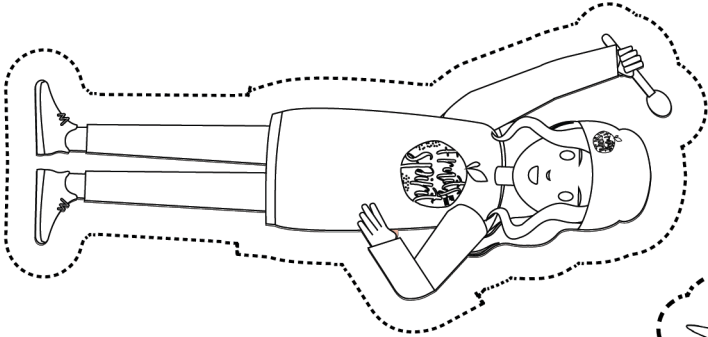

# BORN TO BE JOYFULL

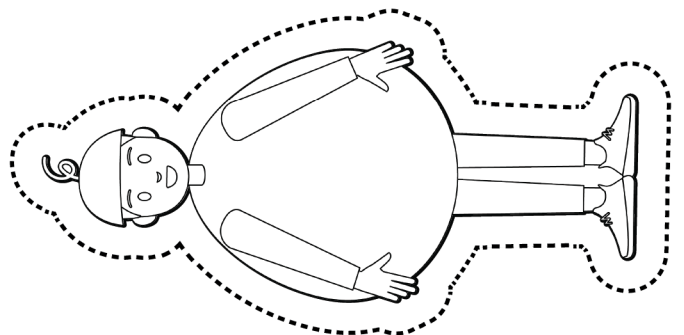
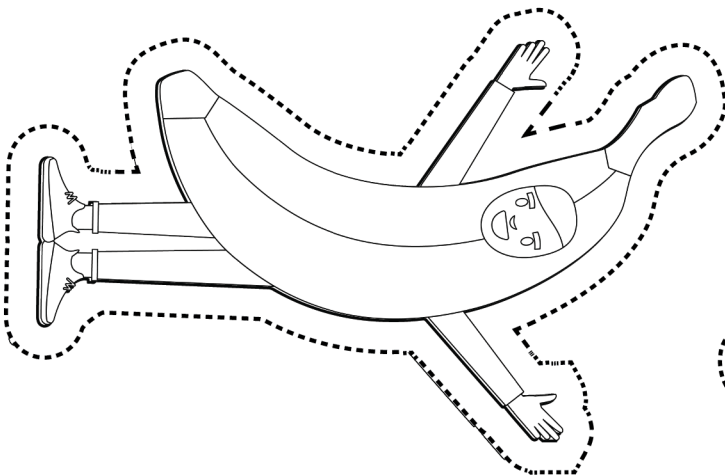
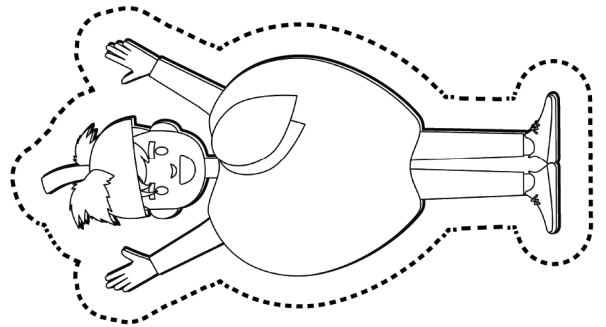
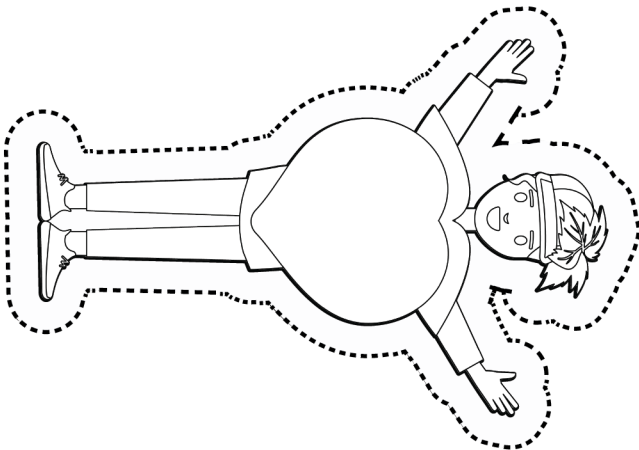
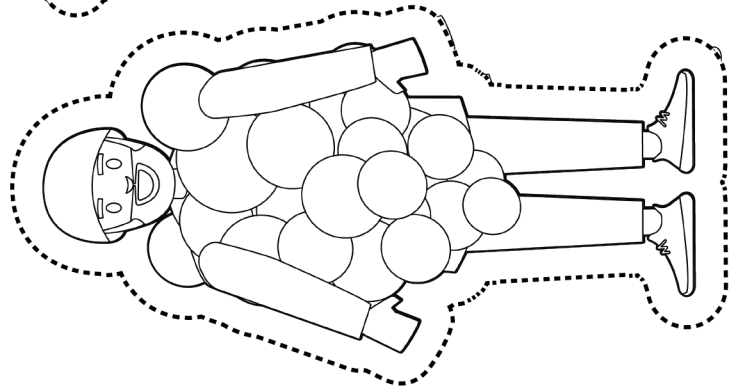
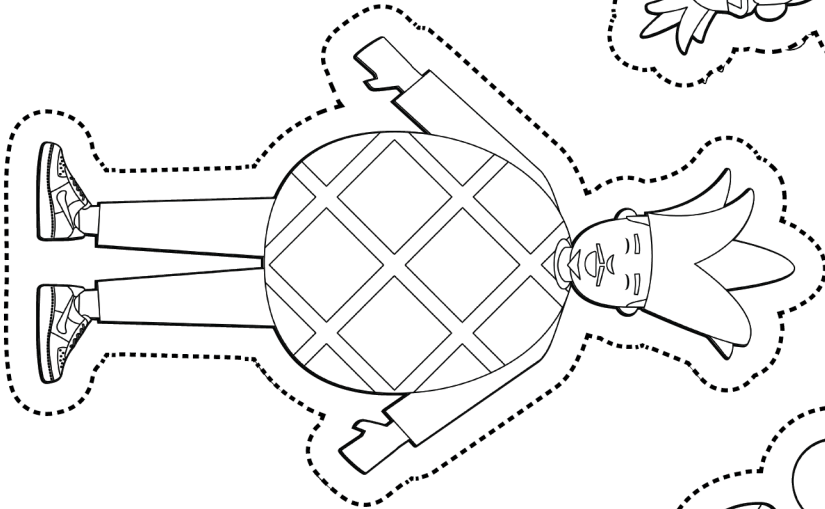
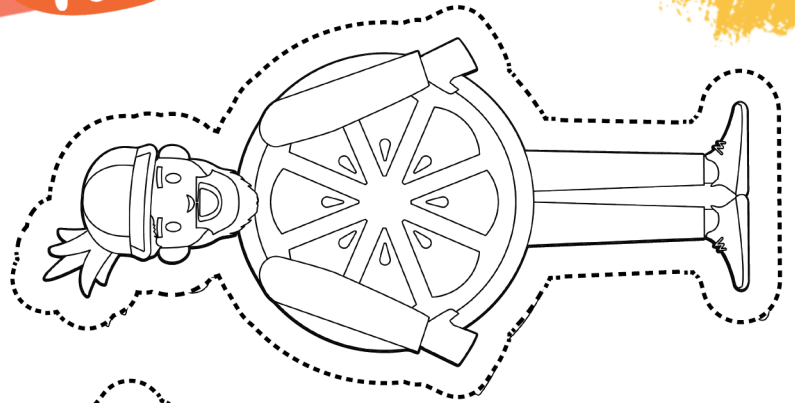

Handwritten text: **BEYOND THE** (part of a larger signature or logo)

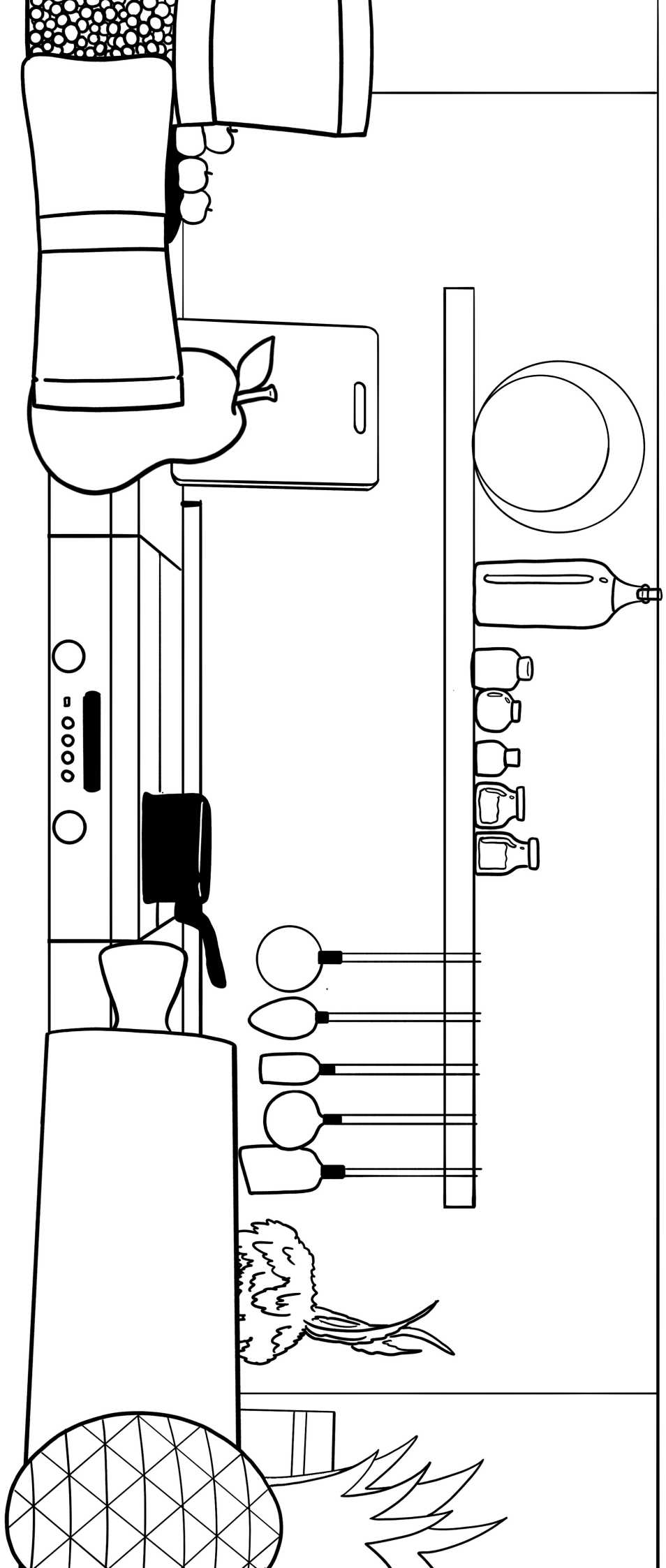

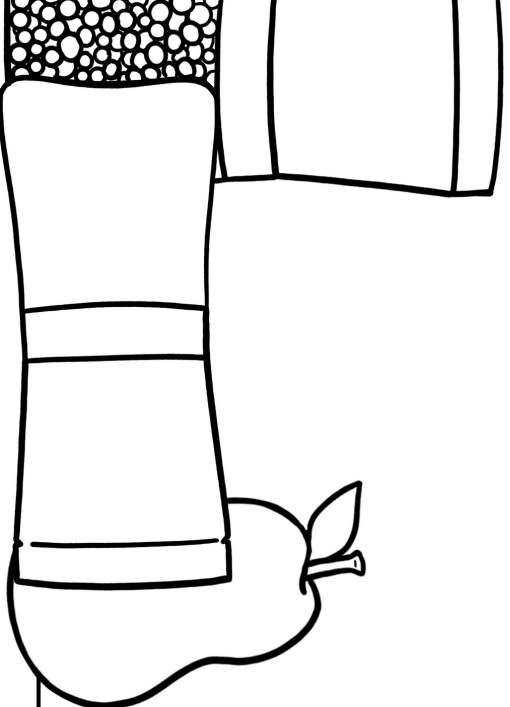

*Handwriting*  
BORN TO BE

