

IBEX™

PISTON® SR MOUNT

ASSEMBLY

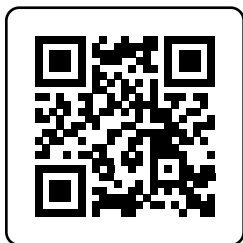

ASSEMBLY VIDEO

Parts

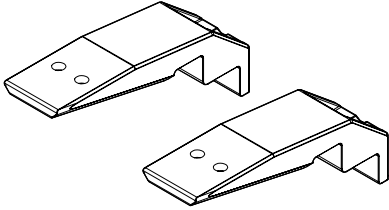

PISTON® SR Mounts



M8 x 16 Bolts (4)

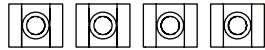

T-Nuts (4)

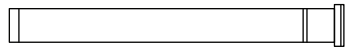

Pedal Strap (1)

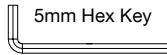

5mm Hex Key

PISTON® SR Mount Installation

- 1 Insert (4) T-Nuts into the T-Nut channels located on both the upper and lower IBEX™ bed rails.

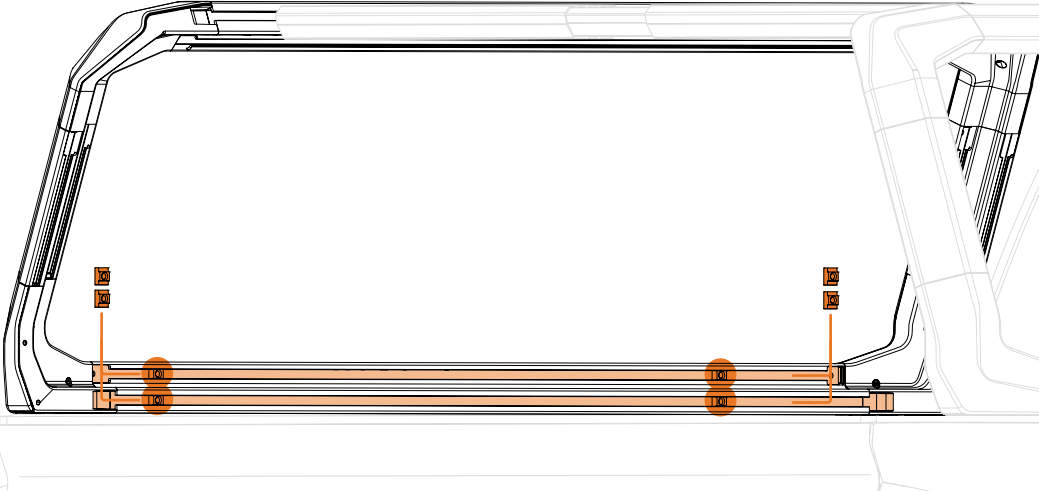

- 2 Install the PISTON® SR Mounts into the T-Nuts by securing them with two M8x16 bolts for each mount. Apply a torque of **21 Nm** during installation. **Do not over-tighten.**

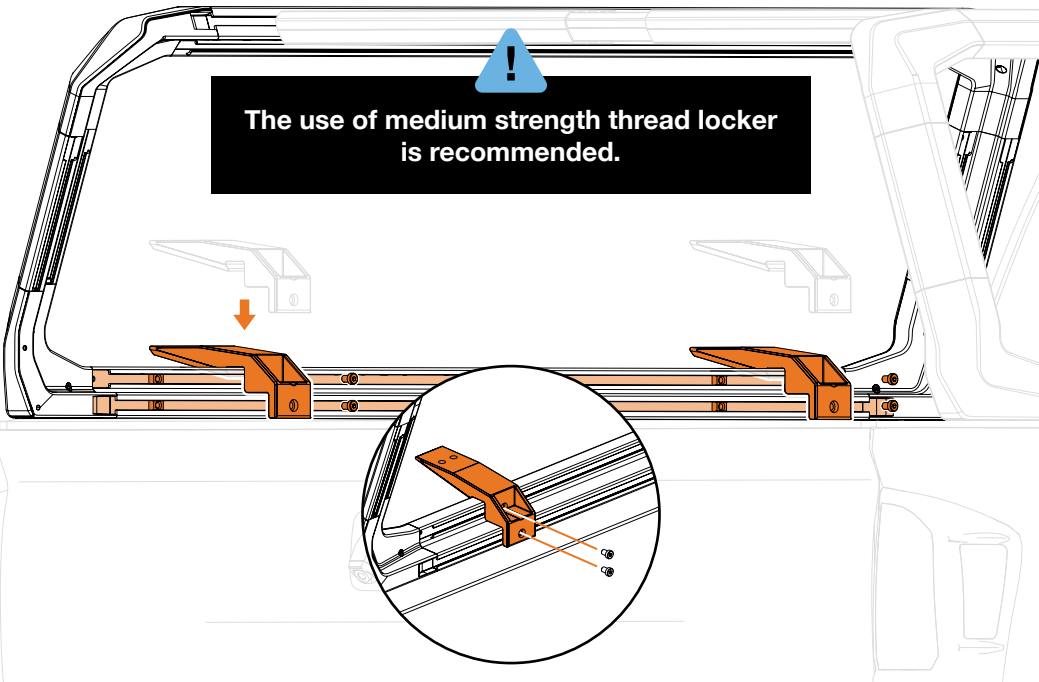

PISTON® SR Installation

- 3 Flip the PISTON® SR over and place (4) short T-Nuts, included with the PISTON® SR, into the T-Channel openings—two on each end. Align two on the left and two on the right to match the bolt holes on your PISTON® SR Mounts.

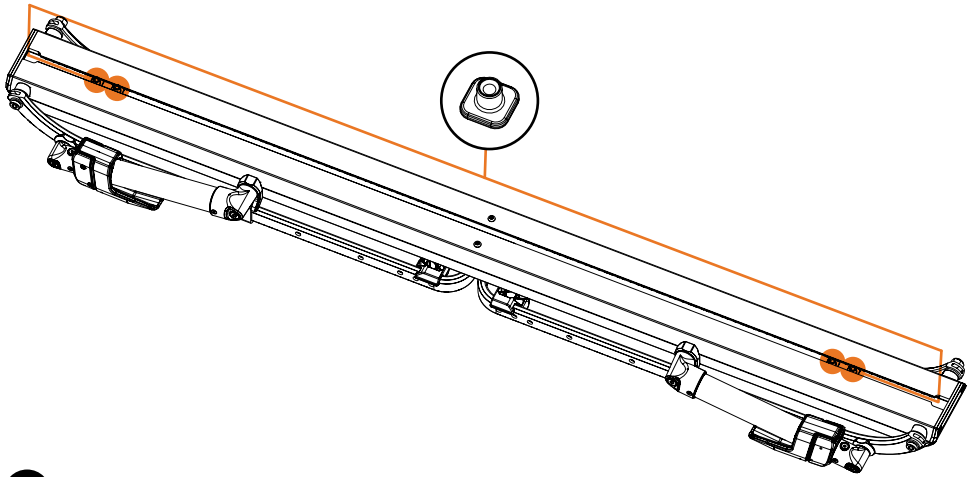

- 4 Fasten the PISTON® SR onto the T-Nuts by using the (4) M6 x 16 bolts provided with the PISTON® SR. Place these bolts on the underside of each PISTON® SR Mount. Apply a torque of **10 - 12 Nm** during the tightening process.
Do not over-tighten.

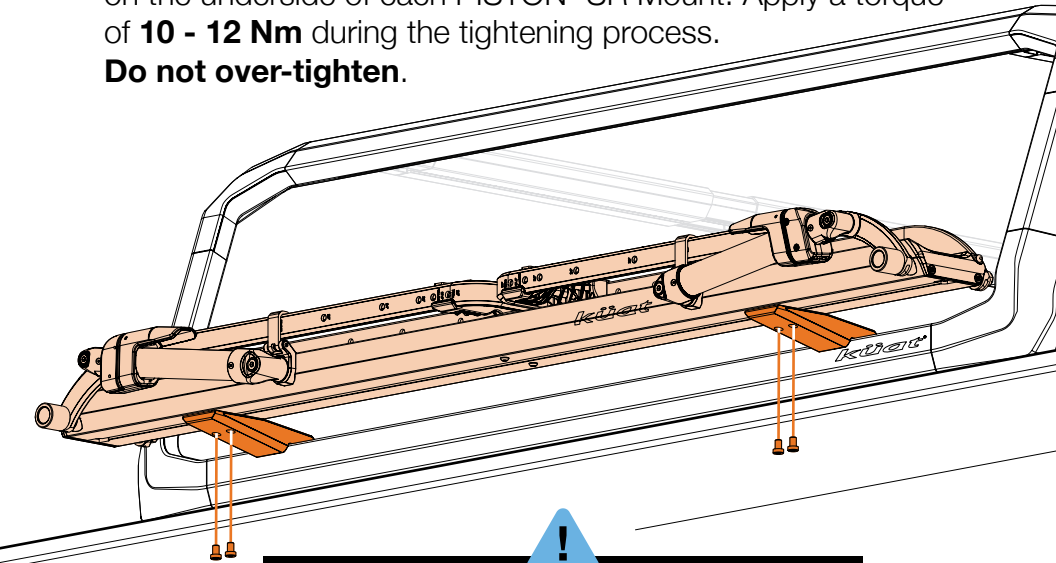

The use of medium strength thread locker is recommended.

Securing Crank Arm

- 5 After you've loaded your bike, position the crank arm to the six o'clock position. For detailed instructions on loading and unloading your bike onto the PISTON® SR, please consult your PISTON® SR user guide.

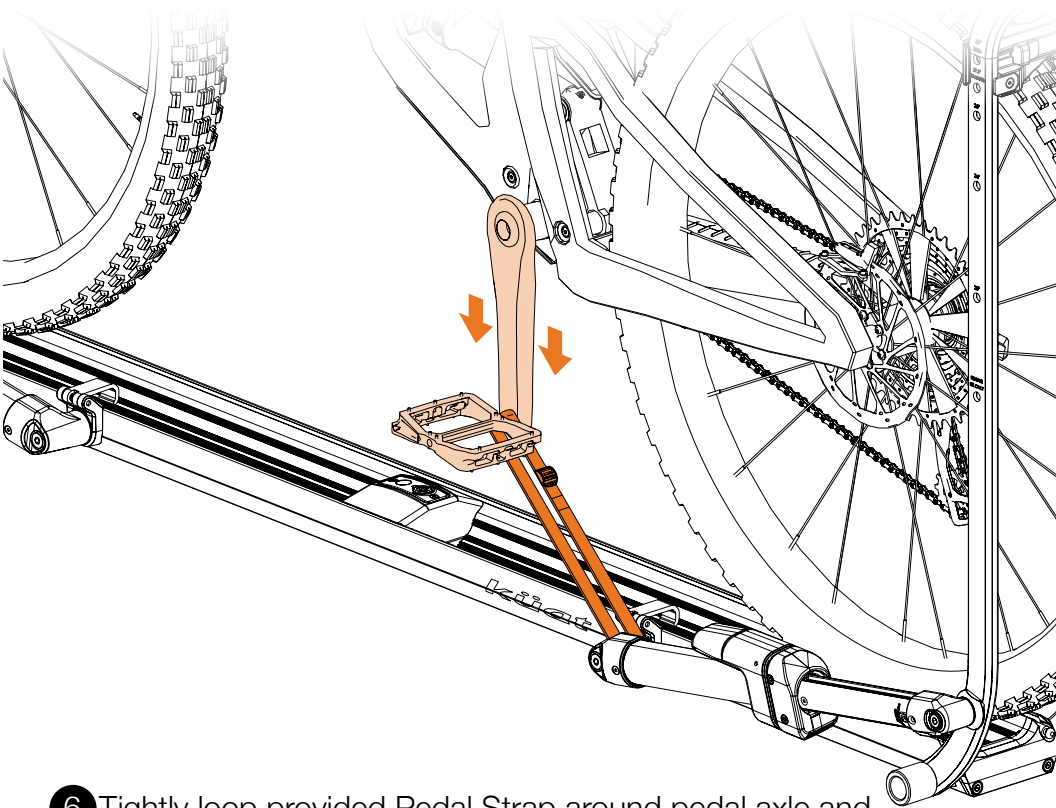

- 6 Tightly loop provided Pedal Strap around pedal axle and PISTON® SR pivot arm to secure crank arm.



Failure to properly secure the Pedal Strap may result in the pedal causing damage to your IBEX™ or IBEX™ accessories.

Warnings

IBEX™

PISTON® SR MOUNT

WARNINGS

- Follow instructions for proper assembly, installation and use.
- Mounts are for attaching PISTON® SR to the IBEX™ only.
- Check tightness of all bolts and screws periodically.
- Make sure rack is in working condition before each use.
- Do not use bicycle fenders or cargo racks with this product without Piston® Fender Kit.
- Do not exceed 67 lbs of weight loaded in this rack.
- Make sure that when loaded, the front tire of your bike is not so far forward that it interferes with the vehicle door.
- This product is not designed for and should not be used on terrain which requires aftermarket upgrades to your 4WD suspension, or use that includes rock-crawling, jumping, bogging, or high speed off road driving. An experienced overland driver is required to take into consideration the speed of the vehicle and the total weight of the vehicle load and its distribution when encountering rutted and/or rocky terrain when using this product, and must reduce the load, speed, or both as necessary. Smooth gravel roads are not considered off-road.
- Do not use tarps, rain covers or wind covers with this product.
- Do not take through automatic car wash.
- Drive responsibly.

If you have questions or problems, please contact Küat directly by calling toll free 1(877)822-KUAT, or by email: info@kuat.com

ADVERTENCIAS

- Siga las instrucciones para un montaje, instalación y uso adecuados.
- Los soportes son para unir PISTON® SR al IBEX™ únicamente.
- Verifique periódicamente el apriete de todos los pernos y tornillos.
- Asegúrese de que el portaequipajes estén en buenas condiciones antes de cada uso.
- No use guardabarros de bicicleta o soportes de carga con este producto sin el kit de guardabarros Piston®.
- No supere los 30 kg de peso cargado en este bastidor
- Asegúrese de que, cuando esté cargada, la llanta delantera de su bicicleta no esté tan adelantada que interfiera con la puerta del vehículo.
- Este producto no está diseñado y no debe usarse en terrenos que requieran mejoras de posventa en su suspensión 4WD, o uso que incluya arrastrarse por rocas, saltar, hacer bogging o conducir a alta velocidad fuera de la carretera. Se requiere que un conductor terrestre experimentado tenga en cuenta la velocidad del vehículo y el peso total de la carga del vehículo y su distribución cuando encuentre terreno con baches y/o rocoso al usar este producto, y debe reducir la carga, la velocidad o ambas según sea necesario. Los caminos lisos de grava no se consideran todoterreno.
- No use lonas, cubiertas para la lluvia o cubiertas contra el viento con este producto.
- No pase por lavado automático de autos.
- Conduzca con responsabilidad.

AVERTISSEMENTS

- Suivez les instructions pour un assemblage, une installation et une utilisation appropriés.
- Les supports sont destinés à fixer le PISTON® SR à IBEX™ uniquement.
- Vérifiez périodiquement le serrage de tous les boulons et vis.
- Assurez-vous que le porte-bagages sont en bon état de fonctionnement avant chaque utilisation.
- N'utilisez pas de garde-boue de vélo ou de porte-bagages avec ce produit sans le kit de garde-boue Piston®.
- Ne dépassez pas 30 kg de poids chargé sur ce rack
- Assurez-vous que lorsqu'il est chargé, le pneu avant de votre vélo n'est pas trop avancé au point d'interférer avec la porte du véhicule.
- Ce produit n'est pas conçu et ne doit pas être utilisé sur des terrains qui nécessitent des mises à niveau de rechange de votre suspension 4WD, ou une utilisation qui inclut l'escalade de roches, les sauts, les embourbages ou la conduite hors route à grande vitesse. Un conducteur terrestre expérimenté doit prendre en considération la vitesse du véhicule et le poids total de la charge du véhicule ainsi que sa répartition lorsqu'il rencontre un terrain accidenté et/ou rocheux lors de l'utilisation de ce produit, et doit réduire la charge, la vitesse ou les deux selon le cas. Nécessaire. Les routes de gravier lisse ne sont pas considérées comme hors route.
- N'utilisez pas de bâches, de housses de pluie ou de housses contre le vent avec ce produit.
- Ne passez pas dans un lave-auto automatique.
- Conduisez de façon responsable.

NO WORRIES LIMITED WARRANTY

We stand behind our products, and our customer service reps are waiting to help you out if you have any problems with your product. Our limited warranty covers your purchase for life. You can review our limited warranty on our website or call customer service at the number below if you have questions or need a repair, replacement, refund, or a copy of the limited warranty.

www.kuat.com/warranty

Questions or comments?

Drop us an email or call us directly!

kuat.com | info@kuat.com | [877.822.5828](tel:877.822.5828)

kuat[®]

1.877.822.5828

info@kuat.com

kuat.com