

PISTON® PRO ADD-ON

ONE BIKE

ASSEMBLY



ASSEMBLY VIDEO

Parts



(2) Tray



(1) M10 x 165 Bolt



(1) M10 Nut



(1) Centerbeam Add-On

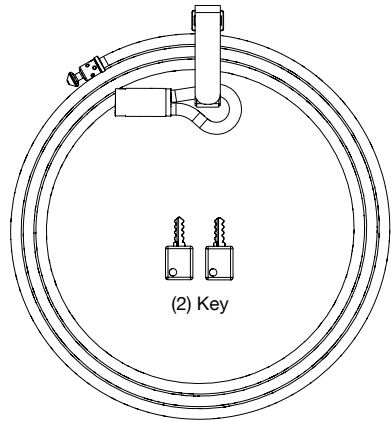

(2) Key

(1) Cable Lock

Tools

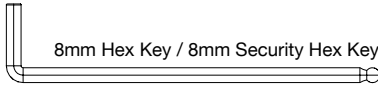

8mm Hex Key / 8mm Security Hex Key

1 Keep your struts clean! Just like your shifters and derailleurs, dirt, dust, and grime can work themselves into the mechanism resulting in sub-par performance. Periodically run a cloth around each Piston® Pro tube to keep your rack looking good and functioning smoothly.

2 Ensure tire cradles make contact with tires. Insufficient contact could result in bicycles becoming loose during travel. Each arm requires at least 1 click of engagement to ensure safe transport.

3 To solve any interference issues, bikes can be loaded in the same direction, or asymmetrically, as well adjusted left and right on their individual trays.

OneTap™ Operation

Deploying Piston® arms provides easier access to tray bolt and tray nut locations.

- 1 Your Piston® Pro Add-On arrived with security tabs beneath each OneTap™ lever to ensure safe shipping. Pull each tab upward to remove them and operate the lever.

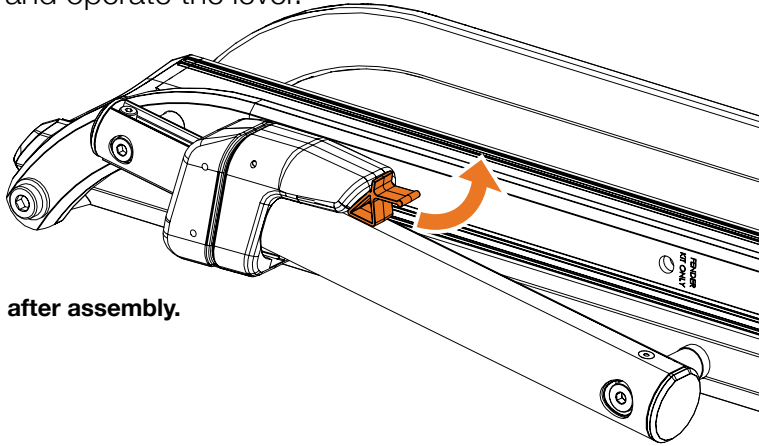

! Dispose of tabs after assembly.

- 2 Open each arm by tapping the OneTap™ levers.
Do not hold the lever down when opening or closing.

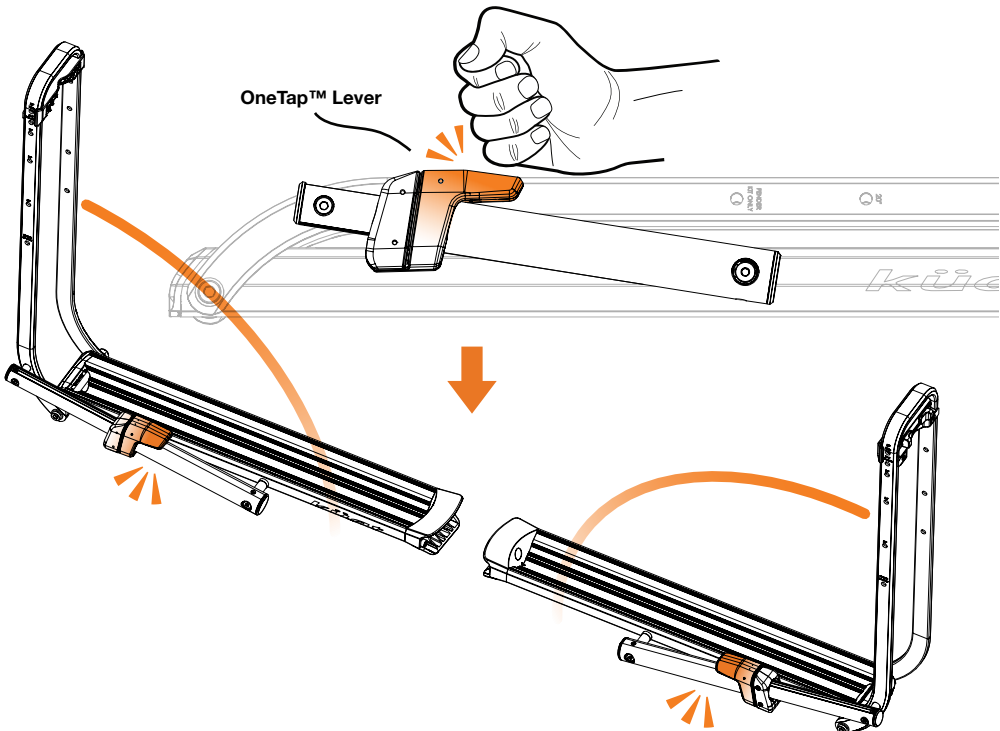

Tray Assembly - Part 1

- 1 Each Piston® tire tray features an EasyClip™ tab that will hook into a slot on the centerbeam, allowing the tire tray to hang in place during assembly.

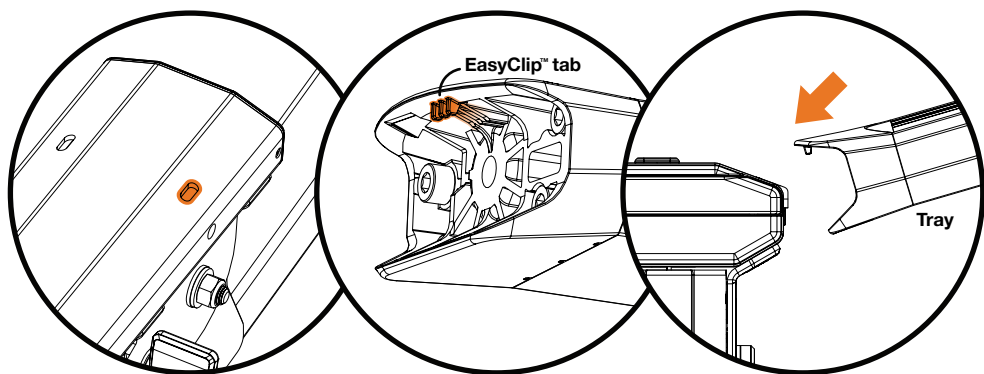

 Angle tire tray to help guide tab as it clips into slot.

Tray Assembly - Expanded View

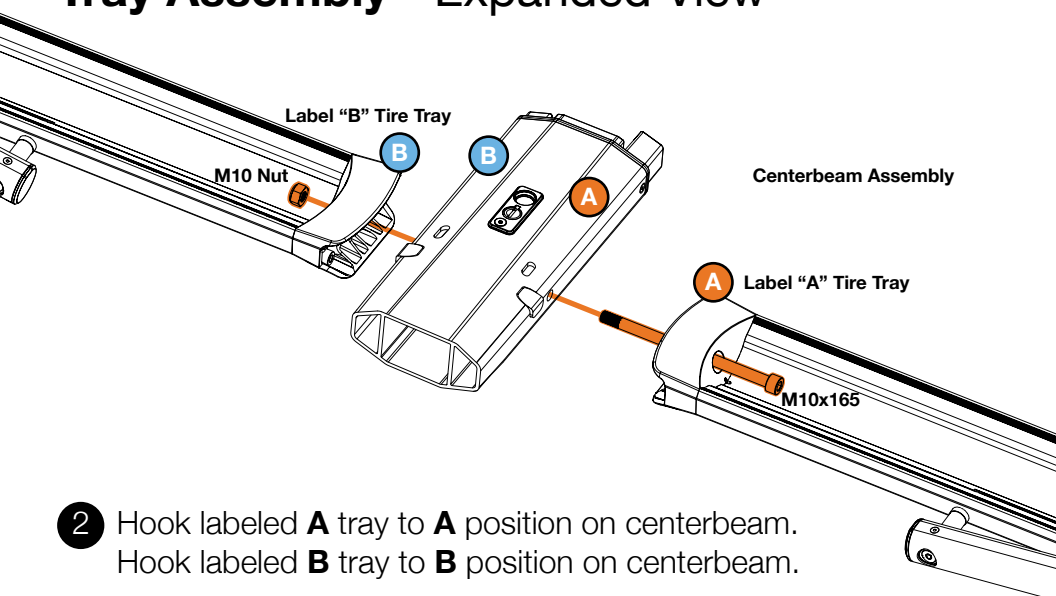

- 2 Hook labeled **A** tray to **A** position on centerbeam. Hook labeled **B** tray to **B** position on centerbeam.

- 2 Hook labeled **A** tray to **A** position on centerbeam.
Hook labeled **B** tray to **B** position on centerbeam.

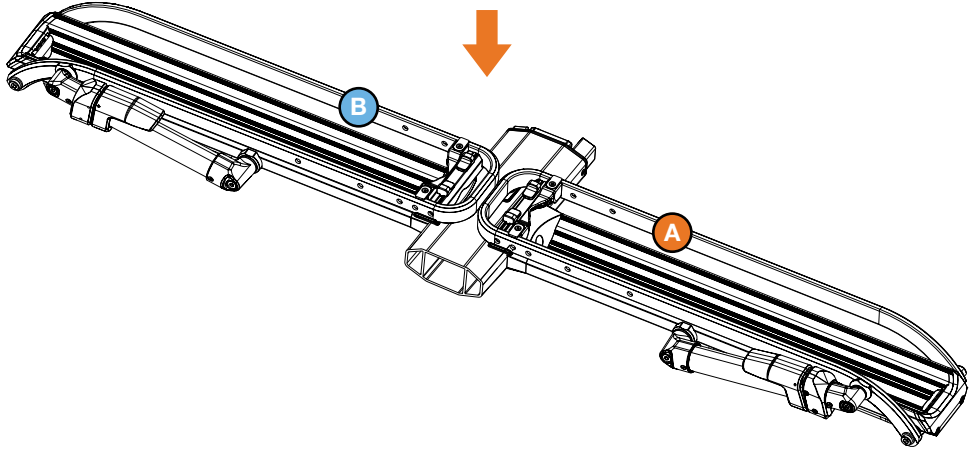
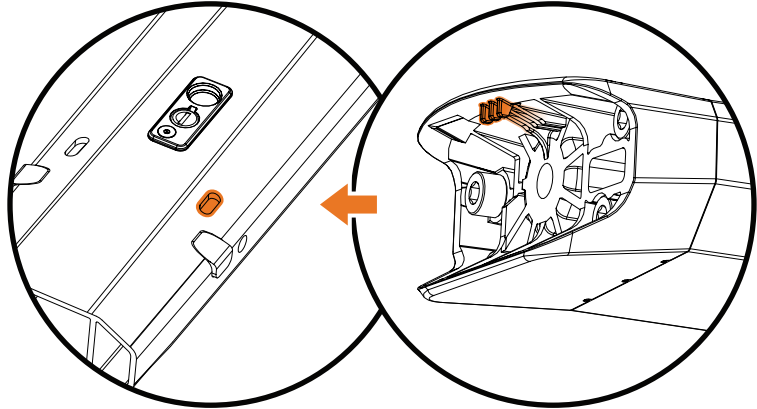
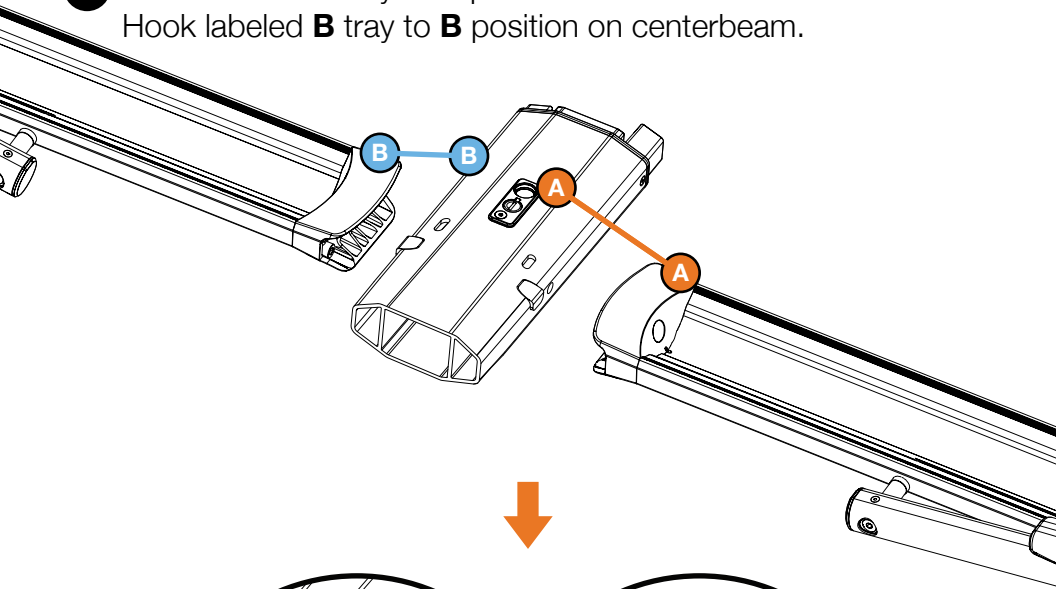

Tray Assembly - Part 2

- 1 Opening Piston® Pro arms provides easier access to tray bolt and tray nut locations.
- 2 With trays held by the EasyClip™ feature, insert M10 nut into **B** tray.

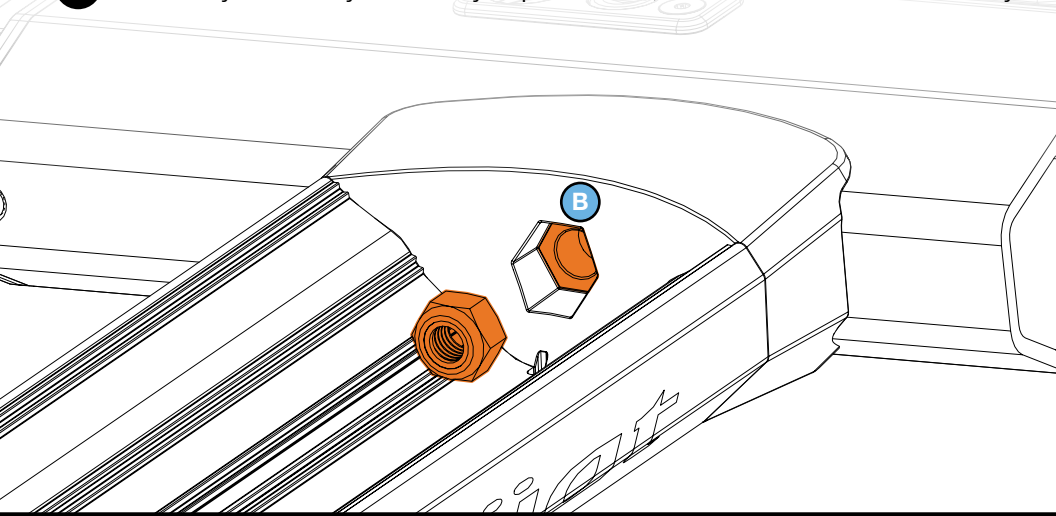

- 3 With M10 nut in place, insert M10x165 into A tray, through centerbeam, and into M10 nut. Tighten with 8mm hex key. **(Torque to 40-50Nm - Do not exceed 50Nm)**

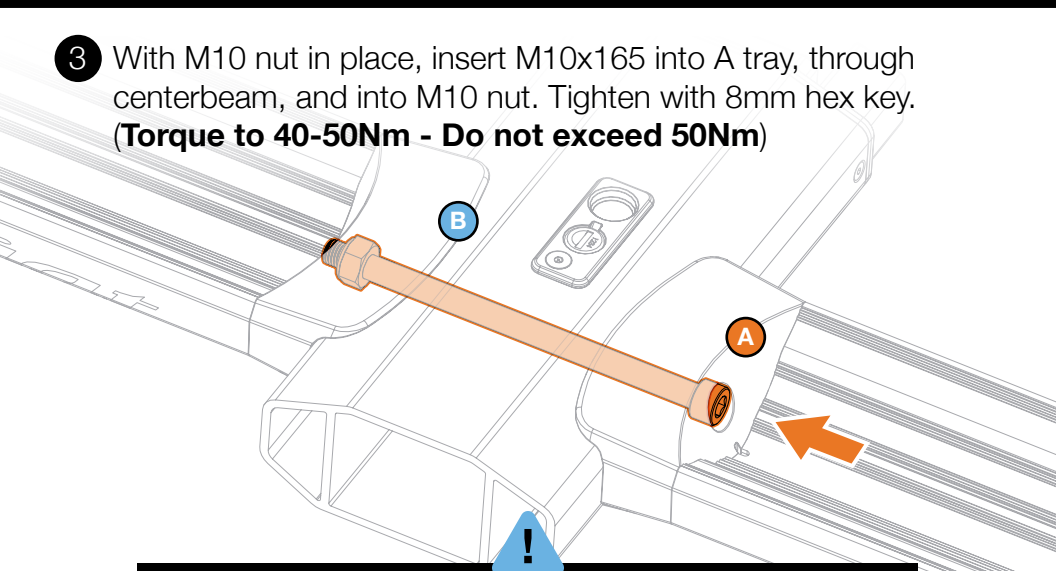

It may be necessary to lift **B** Tray slightly to align bolt holes. Holding **B** Tray M10 Nut in place helps to ensure it stays secured during M10x165 installation and initial tightening.

Add-On Installation

- 1 Using the provided 8mm security hex key, remove center bolt on endcap. Once bolt is removed, pull endcap from the end of main Piston® Pro centerbeam.

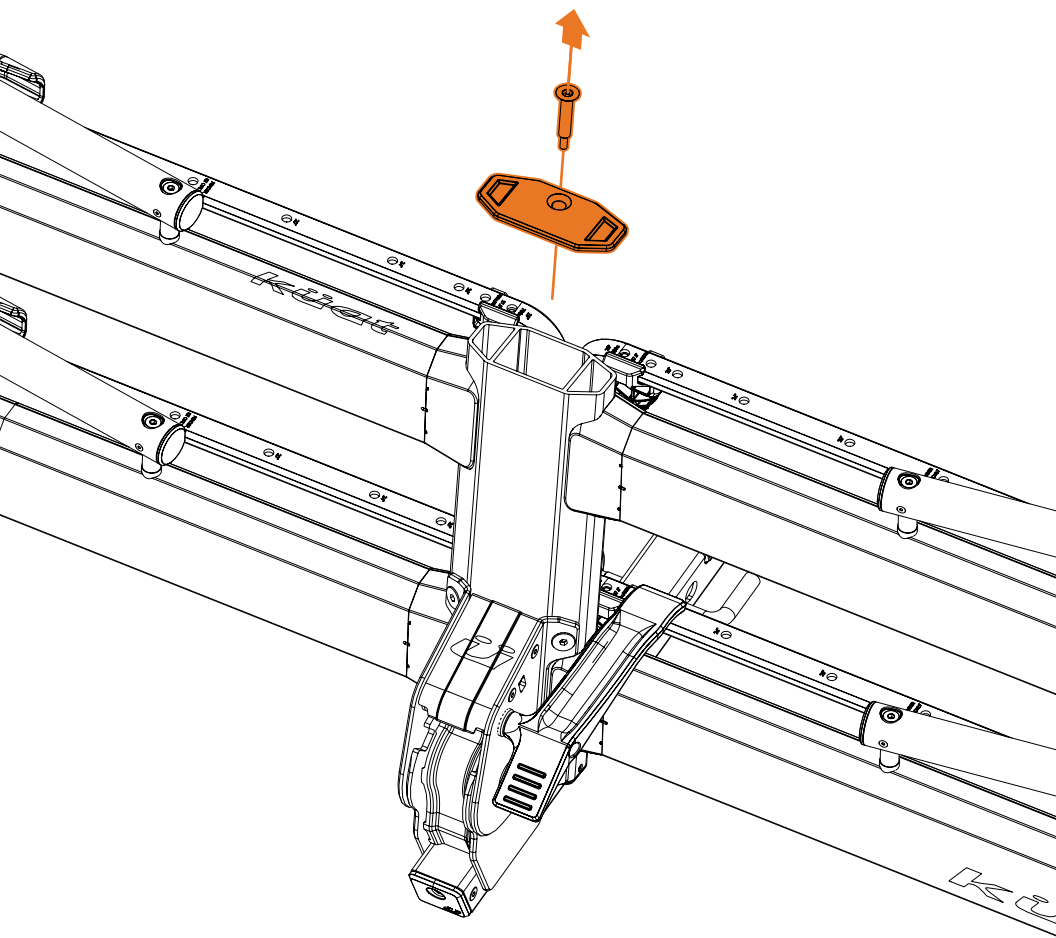

- 2 Insert Add-On into Piston® Pro. For a much easier installation, we recommend inserting the Add-On with Piston® Pro already installed into your vehicle hitch.

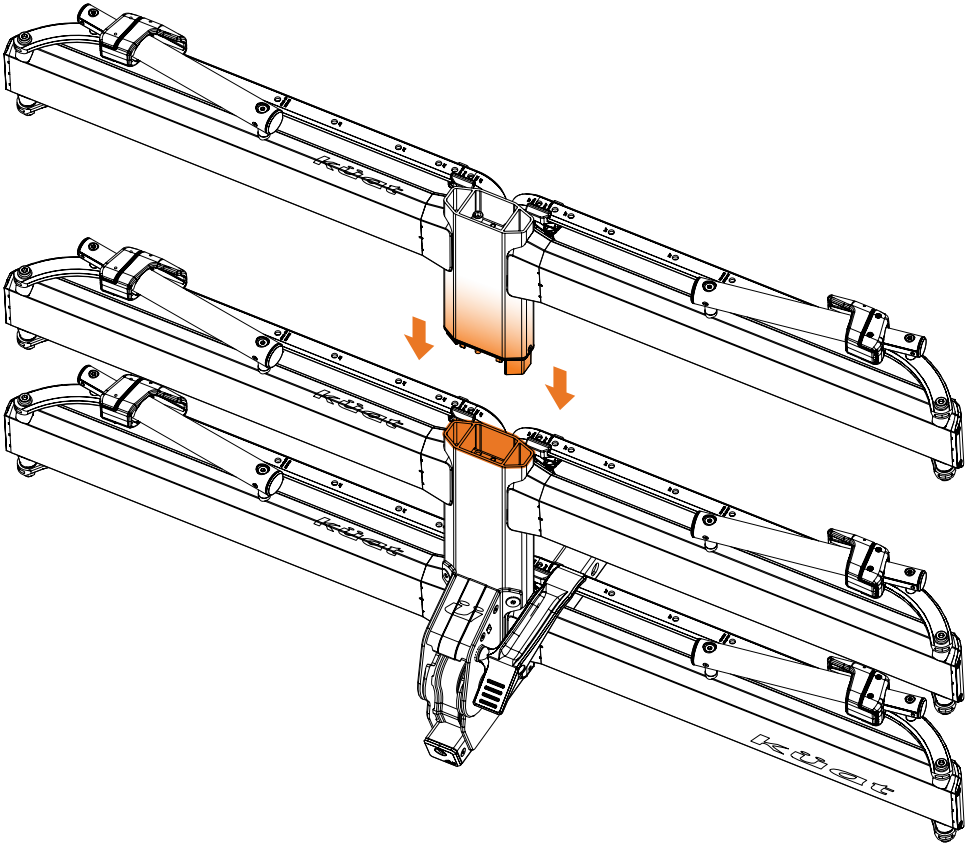

- 3 Using the provided 8mm security hex key, alternate tightening each bolt fully to **20-30Nm**. (**Do not exceed 30Nm**)

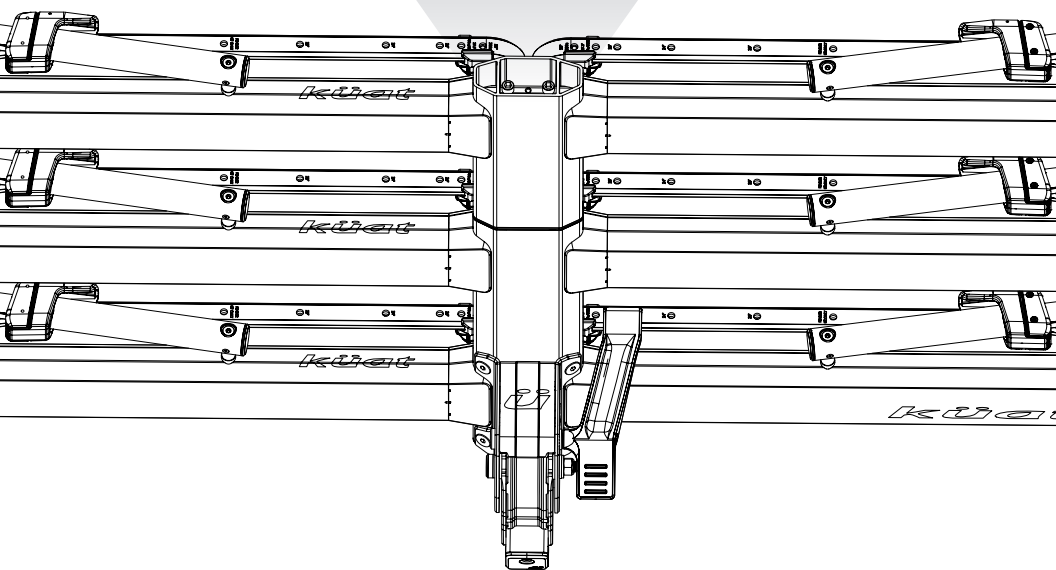
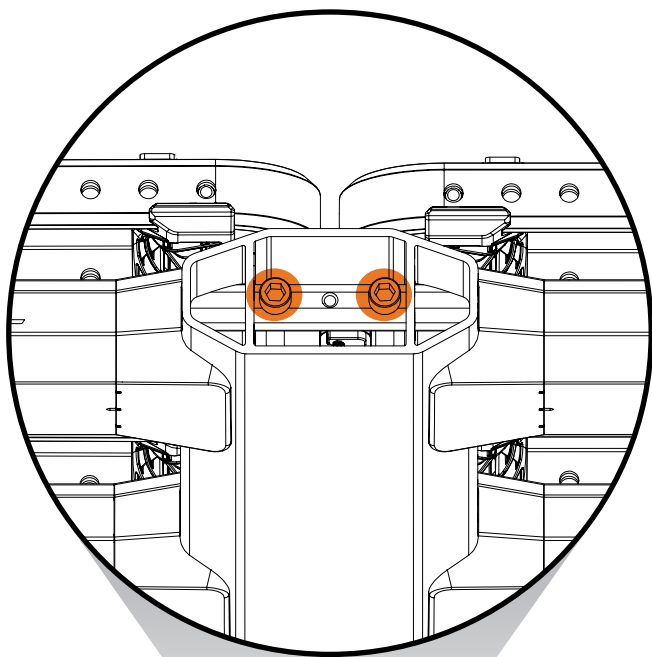

- 4 Reinstall Piston® Pro Add-On endcap and tighten endcap bolt to **5-7Nm**.

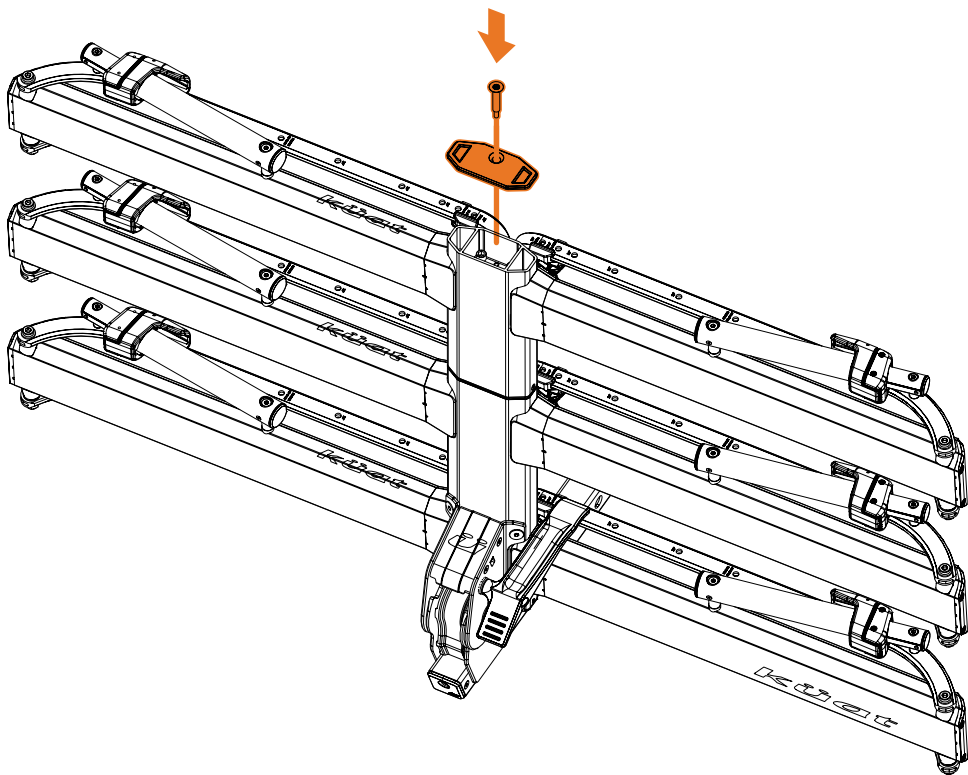

Using Pivot System

- 1 Raise and lower the rack using the lever with your foot or hand to release the pivoting hub.

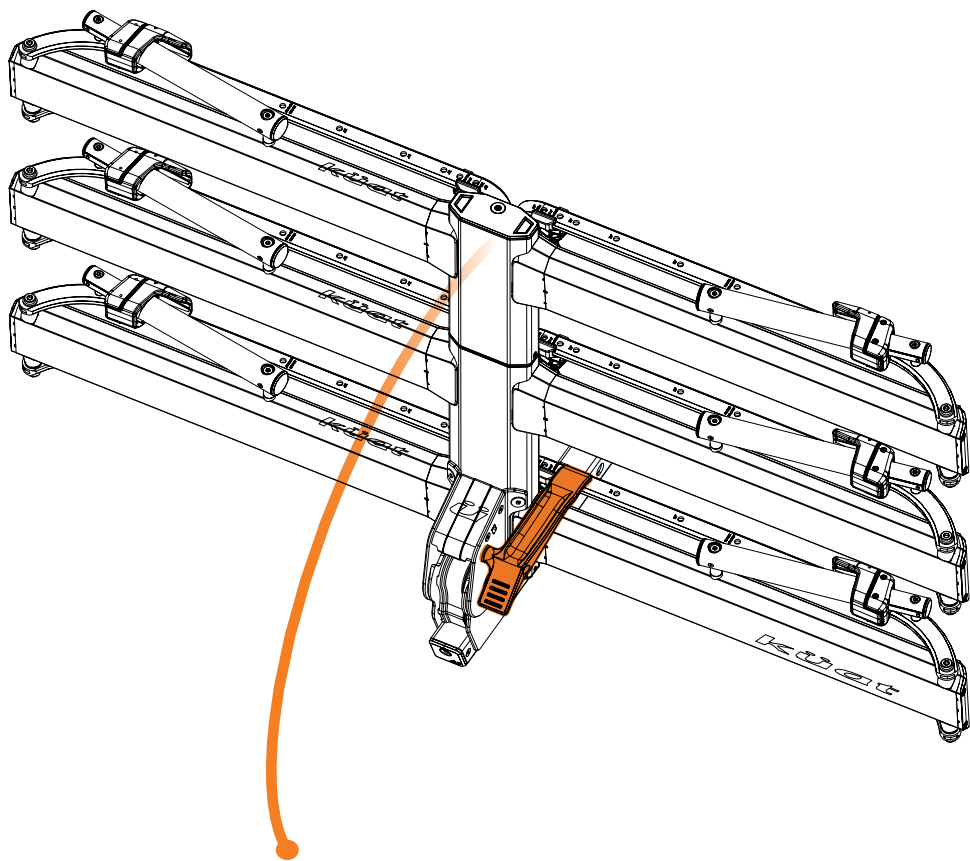

Disassembly

- 1 To revert your Piston® Pro to the 2-bike configuration, disassemble and remove Piston® Pro endcap assembly.
- 2 Using the provided 8mm security hex key, completely loosen both M10 bolts located beneath endcap assembly.

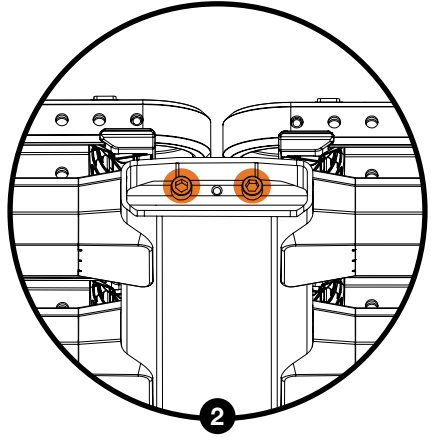
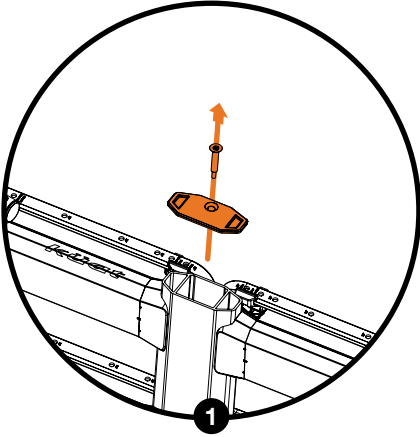

- 3 Lift Add-On up and out of Piston® Pro base unit.

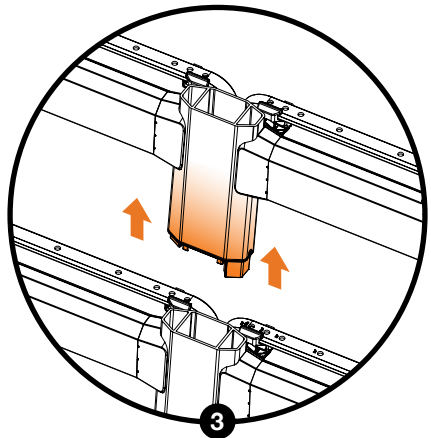
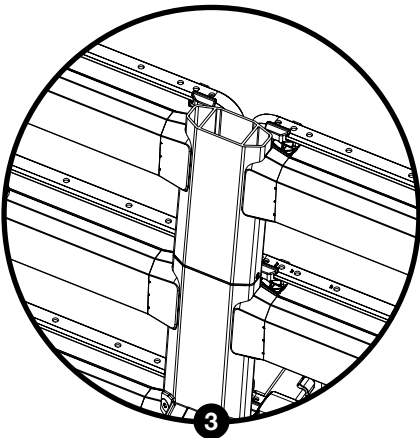

Disassembly - Continued

- 4 Reinstall Piston® Pro endcap and tighten endcap bolt to 5-7Nm.

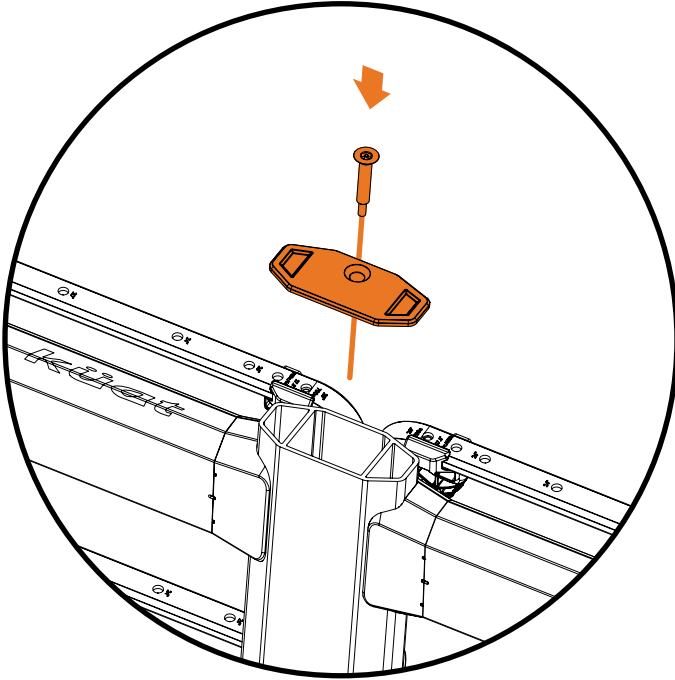

OneTap™ Operation

- 1 Open each arm by tapping the OneTap™ levers. Stand back and watch! Each arm will fully open automatically. **Do not hold the lever while opening or closing.**

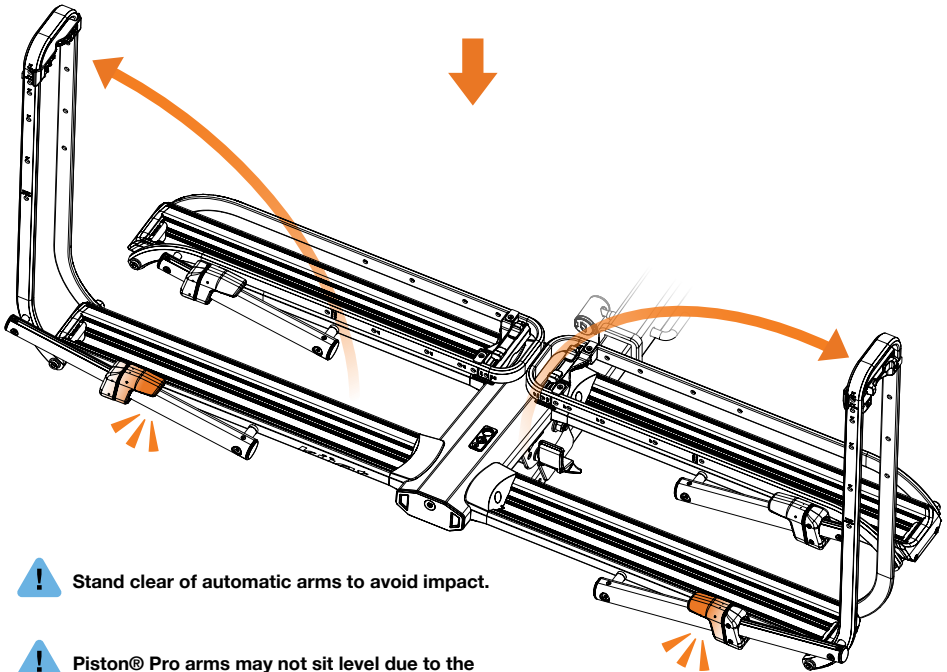
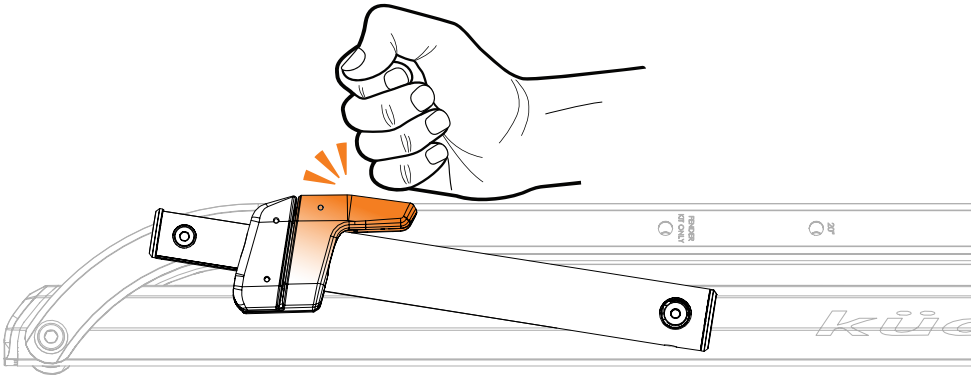

! Stand clear of automatic arms to avoid impact.

! Piston® Pro arms may not sit level due to the back pressure on the piston strut. This is the nature of the design and does not affect the function of the rack.

2 To close, simply push arms back down into stowed position.

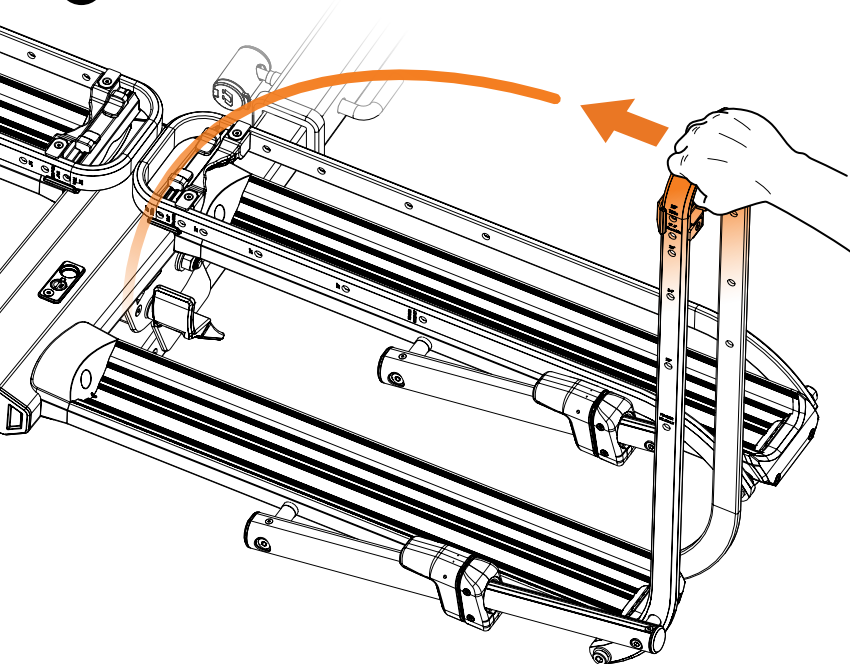

Refer to Piston® Pro user guide for lock, over-center arm function, and bike loading/unloading tips.

eBike Ramp | Selective Bike Unloading

(Sold Separately)

The Piston® OneTap™ system allows users to rotate tire arms into a negative position for the installation of the Piston® eBike Ramp, or conveniently unload a bike in tray 2 without needing to unload tray 1.

To Fold Down

1 Tap OneTap™ lever to open tire arm.

2 Pull arm down into negative position.

! Do not hold OneTap™ lever while pulling arm into negative position.

3 Unload selected bike or install eBike Ramp.

(Sold Separately)

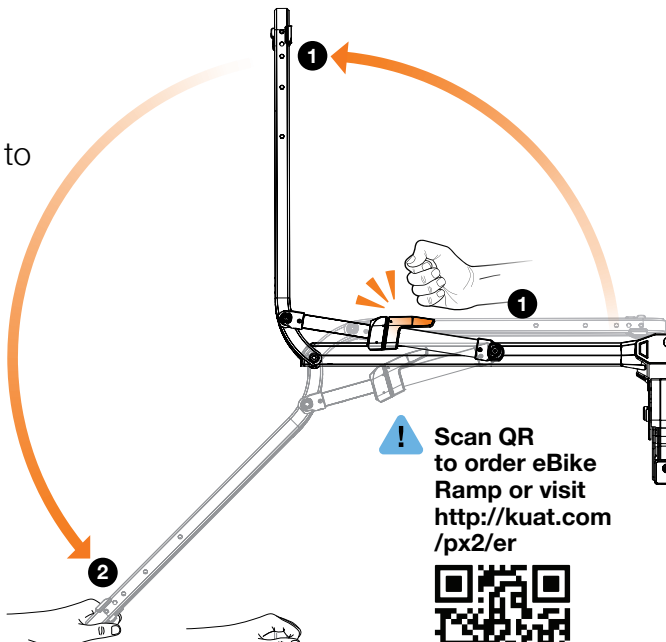

To Fold Up

1 Tap OneTap™ lever to release ratchet tension.

2 Pull tire arm back up into towing, or stowed position.

! Do not hold OneTap™ lever while moving arm into position.

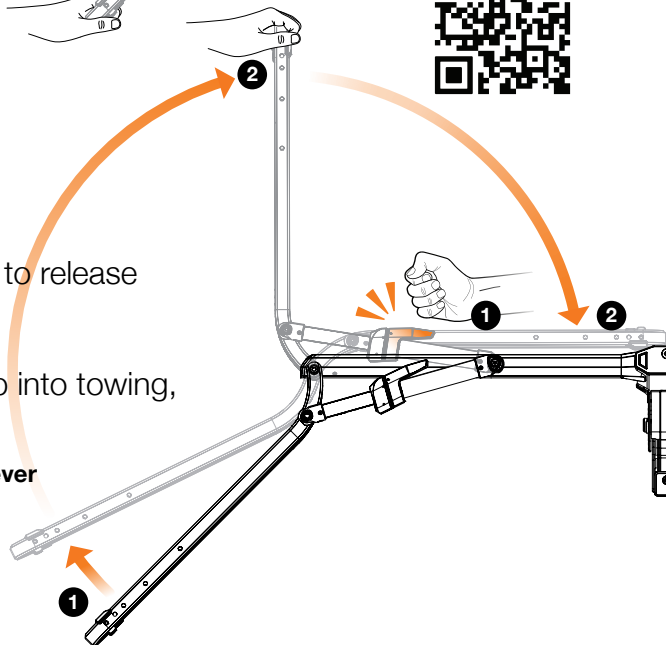

Warnings

PISTON® PRO ADD-ON

ONE BIKE

Number Of Bikes	Max Weight Per Tray On All 3 Trays	Max Wheelbase	Max Tire Width
3	50 lb 22.6kg	53 in 1346 mm	5 in 127 mm

WARNINGS

- Follow instructions for proper assembly, installation and use.
- Check tightness of all bolts and screws periodically.
- Make sure rack and vehicle receiver are in working condition before each use.
- Only use hitch extenders with a tightening mechanism like Küat hitch extenders.
- Do not use bicycle fenders or cargo racks with this product without Piston® Fender Kit.
- Do not exceed the bicycle or weight limits intended for this rack.
- Do not use rack off road (rough, washed out, boulder-and-rut-strewn backroads).
-Smooth gravel roads are not considered off-road.
- Do not use tarps, rain covers or wind covers with this product.
- This Add-On unit is only approved for use on some recreational vehicles.
- Refer to our RV Compatibility Warning for more information
- Do not take through automatic car wash.
- Read the Limited Warranty for additional limitations on use with RV's and hitch extender products.
- Drive responsibly.

If you have questions or problems, please contact Küat Racks directly by calling toll free 1(877)822-KUAT, or by email: info@kuat.com

ADVERTENCIAS

- Siga las instrucciones para un montaje, instalación y uso adecuados.
- Verifique periódicamente el apriete de todos los pernos y tornillos.
- Asegúrese de que el portaequipajes y el receptor del vehículo estén en buenas condiciones antes de cada uso.
- Utilice únicamente extensores de enganche con un mecanismo de apriete como los extensores de enganche Küat.
- No use guardabarros de bicicleta o soportes de carga con este producto sin el kit de guardabarros Piston®.
- No exceda los límites de bicicleta o peso previstos para este portabicicletas.
- No utilice la rejilla fuera de la carretera (carreteras secundarias irregulares, arrasadas, llenas de cantos rodados y surcos).
-Los caminos de ripio liso no se consideran fuera de la carretera.
- No use lonas, cubiertas para la lluvia o cubiertas contra el viento con este producto.
- Esta unidad complementaria solo está aprobada para su uso en algunos vehículos recreativos.
- Consulte nuestra Advertencia de compatibilidad de vehículos recreativos para obtener más información
- No pase por lavado automático de autos.
- Lea la Garantía limitada para conocer limitaciones adicionales sobre el uso con productos de extensión de enganche y vehículos recreativos.
- Conduzca con responsabilidad.

AVERTISSEMENTS

- Suivez les instructions pour un assemblage, une installation et une utilisation appropriés.
- Vérifiez périodiquement le serrage de tous les boulons et vis.
- Assurez-vous que le porte-bagages et le récepteur du véhicule sont en bon état de fonctionnement avant chaque utilisation.
- Utilisez uniquement des rallonges d'attelage avec un mécanisme de serrage comme les rallonges d'attelage Küat.
- N'utilisez pas de garde-boue de vélo ou de porte-bagages avec ce produit sans le kit de garde-boue Piston®.
- Ne dépassez pas les limites de vélo ou de poids prévues pour ce porte-bagages.
- N'utilisez pas de crémaillère hors route (routes secondaires accidentées, délavées, parsemées de rochers et d'ornières).
-Les routes en gravier lisse ne sont pas considérées comme hors route.
- N'utilisez pas de bâches, de housses de pluie ou de housses contre le vent avec ce produit.
- Cette unité supplémentaire n'est approuvée que pour une utilisation sur certains véhicules récréatifs.
- Reportez-vous à notre avertissement de compatibilité RV pour plus d'informations
- Ne passez pas dans un lave-auto automatique.
- Lisez la garantie limitée pour connaître les limitations supplémentaires sur l'utilisation avec les produits de VR et d'extension d'attelage.
- Conduisez de façon responsable.

LIMITED WARRANTY

We stand behind our products, and our customer service reps are waiting to help you out if you have any problems with your product. Our limited warranty covers your purchase for life. You can review our limited warranty on our website or call customer service at the number below if you have questions or need a repair, replacement, refund, or a copy of the limited warranty.

www.kuat.com/warranty

Questions or comments?

Drop us an email or call us directly!

kuat.com | info@kuat.com | [877.822.5828](tel:877.822.5828)

Küat RV Compatibility Warning

Küat's limited warranty only covers use of some of its receiver hitch-mounted bicycle racks with some recreational vehicles (RVs) as described below. Many types of RVs subject the rack and bicycles on it to high forces and extreme movements. Damage resulting from use of a Küat product in violation of this section is not covered by this limited warranty.

Küat's limited warranty will cover use of any of its 2-inch receiver hitch-mounted bicycle racks on motorhomes (as defined in 49 C.F.R. 571.3) satisfying all of the following requirements:

The receiver hitch is directly attached to the motorhome chassis, not just to the bumper;
The rear-most point of the receiver hitch where the bicycle rack will be attached is no more than 64 inches from the rear axle of the motorhome; and

The vehicle is a class B type motorhome as described below.

Class B type motorhomes are commonly known as van conversions and comprise a completed van-type vehicle which has been altered to provide temporary living quarters. Class B type motorhomes have a gross vehicle weight rating of 10,000 lbs or less.

In addition, (i) the 2 inch receiver Transfer™ v2, (ii) the 2-inch receiver Piston Pro X, and (iii) the Piston SR with 2" Hitch Adapter may be used on RVs (both motorhomes and trailers) satisfying all of the following requirements:

The receiver hitch is directly attached to the RV chassis, not just to the bumper; and
The bicycle rack is in the 2-bike configuration with no add-on unit attached.

Please check the User Guide for load weight limits applicable to your rack when used on an RV. Lower weight limits apply.

Even if the conditions above are met, any RV may be operated in a way that will expose Küat's products to conditions that they are not designed to handle. The operator of the RV is responsible to operate the RV in a manner that will not overload the rack, such as by excessive speed over rough roads or speed bumps, rapid turning movements, driving the RV over changes in gradient that will bring the rack in contact with the ground, or other similar actions.

Receiver Hitch Capacity Warning

This section is applicable only to Küat products that are used in conjunction with a receiver hitch. The weight capacity of your vehicle's receiver hitch depends on many factors, including (i) its hitch class rating, (ii) whether it is attached to the vehicle frame or the bumper, (iii) its maximum tongue weight, and (iv) other factors based on your vehicle's design. Küat cannot evaluate whether your particular vehicle/receiver hitch combination is sufficient for use with Küat products. You are responsible to determine the weight carrying capacity of your vehicle and its receiver hitch. Please consult your vehicle owner's manual and hitch receiver manual to determine if your vehicle/receiver hitch combination has the necessary capacity for a specific Küat product and your bicycles. The combined weight of the bicycle rack and bicycles is not directly comparable to the maximum tongue weight for your receiver hitch because of the distance from the receiver hitch to the position where the bicycles are supported on the rack. Using hitch extenders such as the Hi-Lo or Hi-Lo Pro, or swing arms such as the Pivot or Pivot v2 products, increases the effective load on your receiver hitch even further.

The Pivot, Pivot v2, or similar swing arm products should never be used with Class I or Class II hitch receivers. Depending on the number, weight, and placement of bicycles on the rack, some Class III or Class IV hitch receivers may not have the capacity for a bicycle rack on a swing arm.

You are responsible to determine if your receiver hitch has the capacity to support a hitch extender product (Hi-Lo, Hi-Lo Pro, etc.) or swing arm (Pivot, Pivot v2, etc.) with a particular combination of bicycles and bicycle rack. You should not attach a vertical or hanging style bicycle rack to a hitch extender or swing arm.

AS A RESULT OF THE FOREGOING, KÜAT'S LIMITED WARRANTY DOES NOT COVER DAMAGE OR LOSS, INCLUDING PROPERTY DAMAGE, PHYSICAL INJURY OR DEATH, ARISING FROM USE OF ITS PRODUCTS WITH A VEHICLE/RECEIVER HITCH COMBINATION THAT DOES NOT HAVE THE CAPACITY FOR THE PRODUCT OR CONFIGURATION USED BY YOU ON IT, AND KÜAT DISCLAIMS ANY EXPRESS OR IMPLIED WARRANTY RELATING TO THE CAPACITY OF A VEHICLE OR RECEIVER HITCH FOR USE WITH A PARTICULAR KÜAT PRODUCT OR COMBINATION OF KÜAT PRODUCTS, INCLUDING ANY IMPLIED WARRANTY OF MERCHANTABILITY OR FITNESS FOR A PARTICULAR PURPOSE RELATED THERETO. THIS DISCLAIMER MAY NOT APPLY IN ALL STATES.

kuat[®]

1.877.822.5828

info@kuat.com

kuat.com