

PISTON[®] PRO X

TWO BIKE

ASSEMBLY

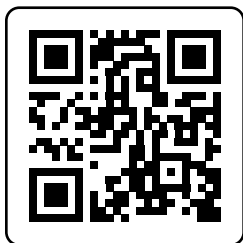

ASSEMBLY VIDEO

Parts



(1) Foot Lever



(2) Key

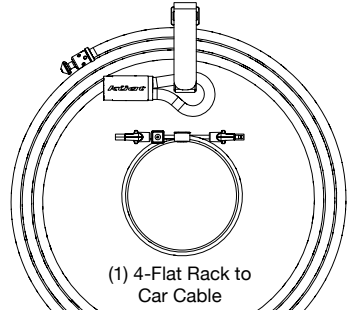

(1) 4-Flat Rack to Car Cable

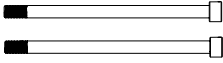

(2) M10 x 165 Bolt



(2) M10 Nut



(1) M6 x 45



(1) M6 Washer

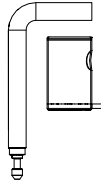

(1) Hitch Pin

(1) Hitch Lock

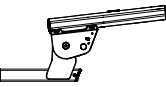

(1) Centerbeam



(4) Tray

Tools

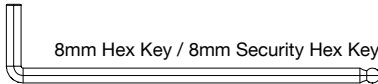

8mm Hex Key / 8mm Security Hex Key

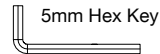

5mm Hex Key

1 We recommend inserting centerbeam assembly into a hitch for a greatly improved assembly experience.

2 Keep your struts clean! Just like your shifter and derailleur, dirt, dust, and grime can work themselves into the mechanism resulting in sub-par performance. Periodically run a cloth around each Piston® tube to keep your rack looking good and functioning smoothly.

3 Assembly of the 2" Receiver and 1.25" Receiver versions of the Piston® are virtually identical. Minor differences in the hitch installation processes are shown.

Hitch Installation

- 1 Insert centerbeam assembly into your hitch receiver.

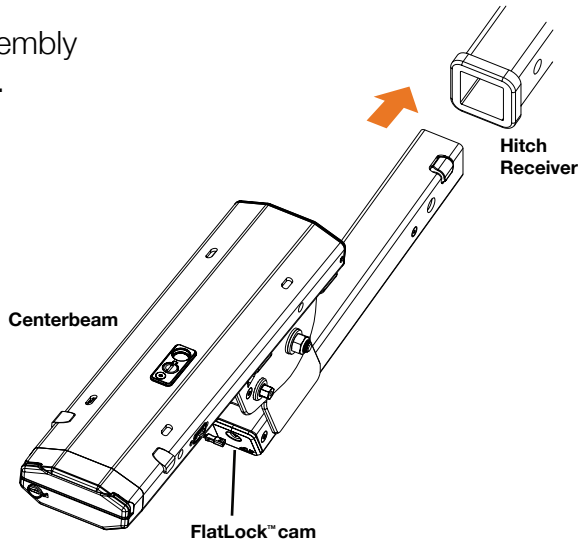

- 2 Find and unlock the 8mm security hex key found at the front of the centerbeam assembly to tighten FlatLock™ cam and secure Piston® in your hitch.

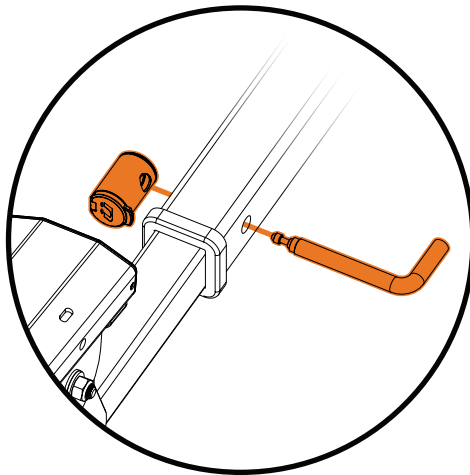

- 3 Insert hitch pin through holes in hitch receiver and Piston® shank, and secure with hitch pin lock.

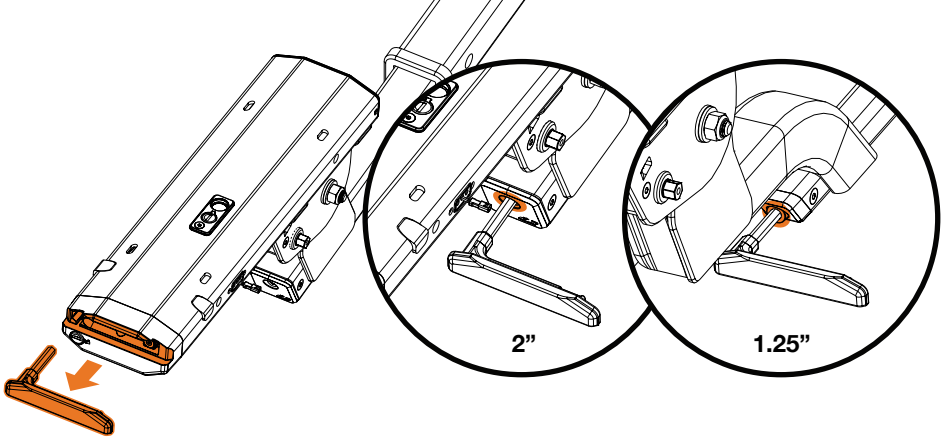

- 4 Fully tighten FlatLock™ cam to secure centerbeam in hitch receiver.

! Remember to reinstall and secure security hex with provided key.

Foot Lever Assembly

- 1 Slide foot lever into position on centerbeam assembly, installing M6 Washer and M6x45 bolt using the provided 5mm hex key.

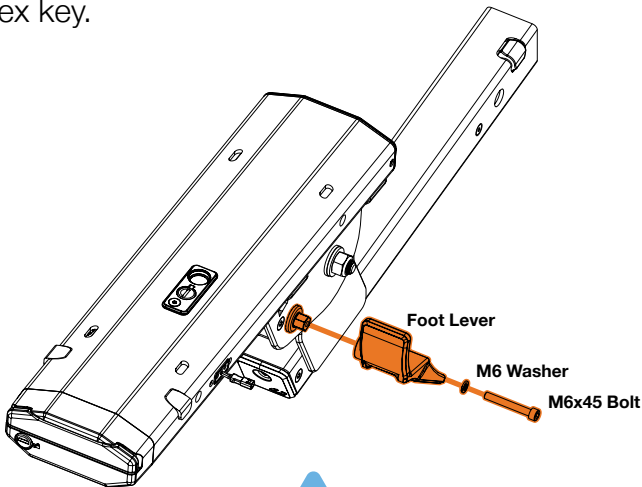

Tighten M6x45 bolt to 15Nm.

OneTap™ Operation

Deploying Piston® arms provides easier access to tray bolt and tray nut locations.

- 1 Your Piston® arrived with security tabs beneath each OneTap™ lever to ensure safe shipping. Pull each tab upward to remove them and operate the lever.

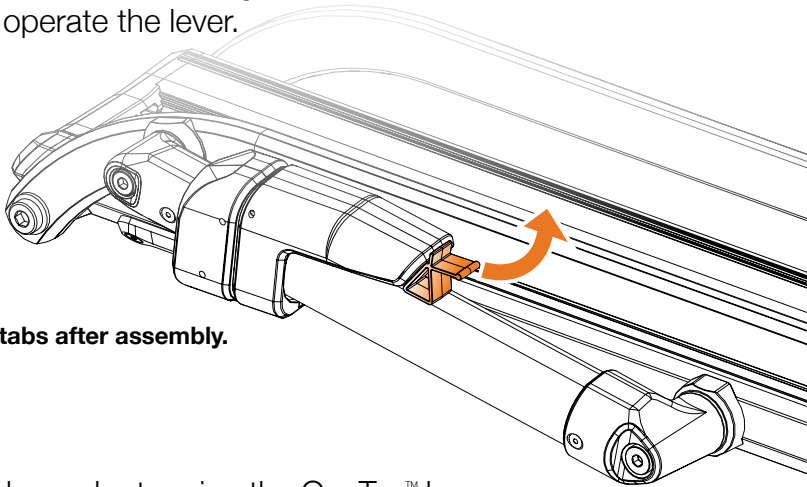

! Dispose of tabs after assembly.

- 2 Open each arm by tapping the OneTap™ levers.
Do not hold the lever down when opening or closing.

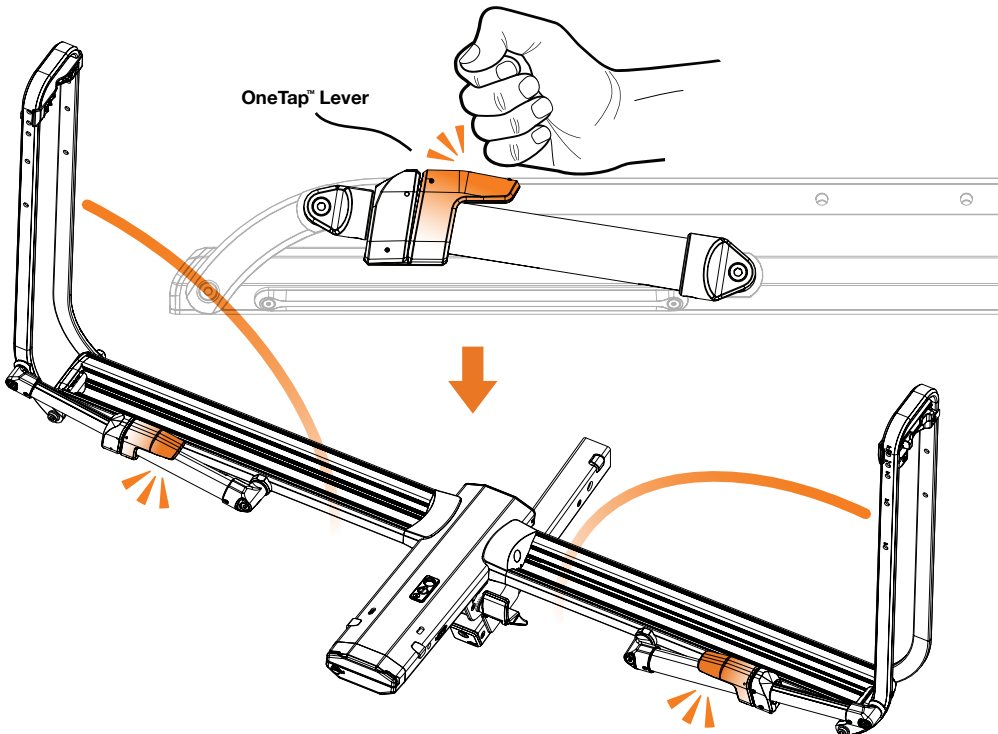

Tray Assembly - Part 1

- 1 Each Piston® tire tray features an EasyClip™ tab that will hook into a slot on the centerbeam, allowing the tire tray to hang in place during assembly.

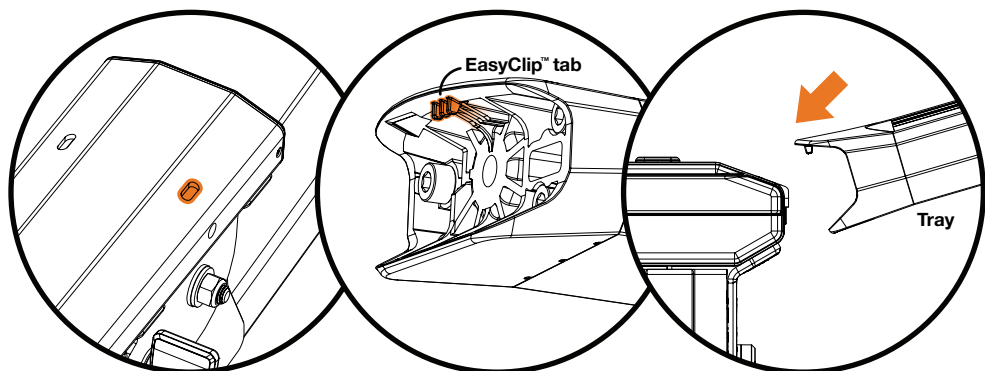

! Angle tire tray to help guide tab as it clips into slot.

Tray Assembly - Expanded View

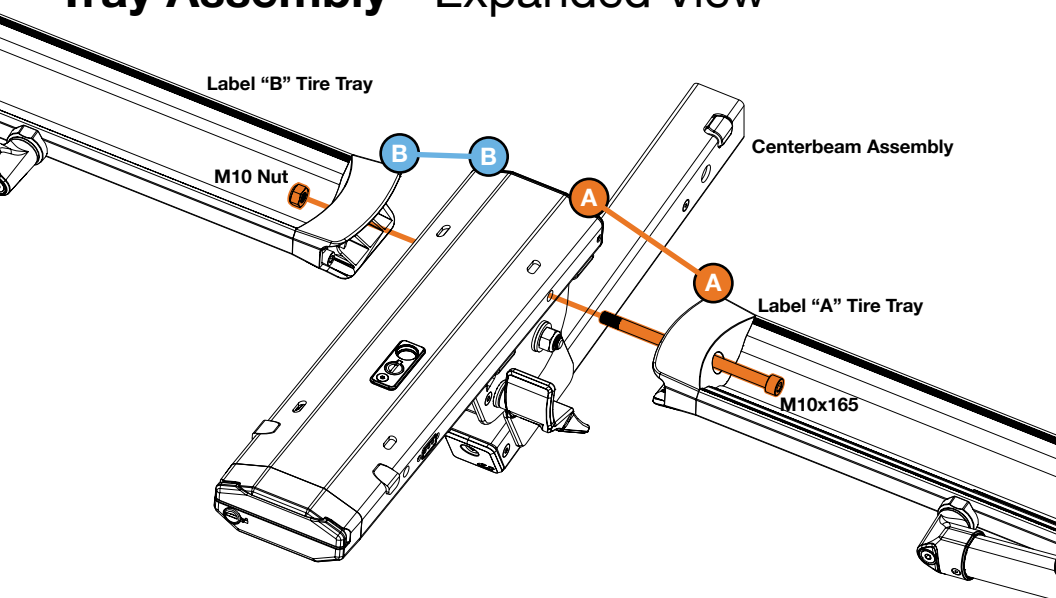

- 2 Hook labeled **A** tray to **A** position on centerbeam.
Hook labeled **B** tray to **B** position on centerbeam.

3 Opening Piston® arms provides easier access to tray bolt and tray nut locations.

4 With trays secured, insert M10 nut into **B** tray.

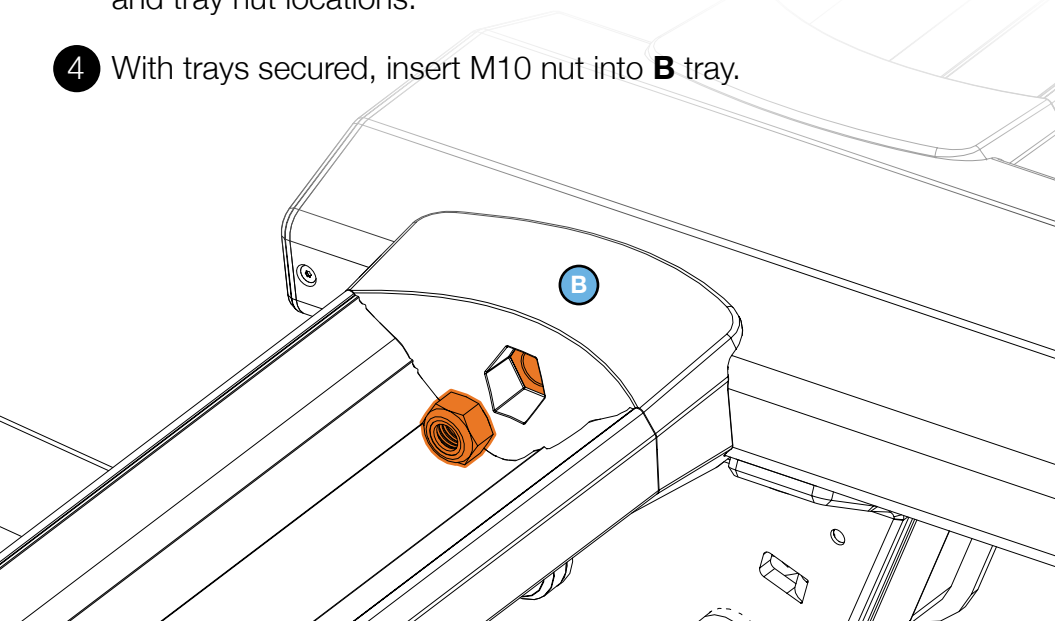

5 With M10 nut in place, insert M10x165 into **A** tray, through centerbeam, and into M10 Nut. Tighten with 8mm hex key. (Recommended torque to **40-50Nm - Do not exceed 50Nm**)

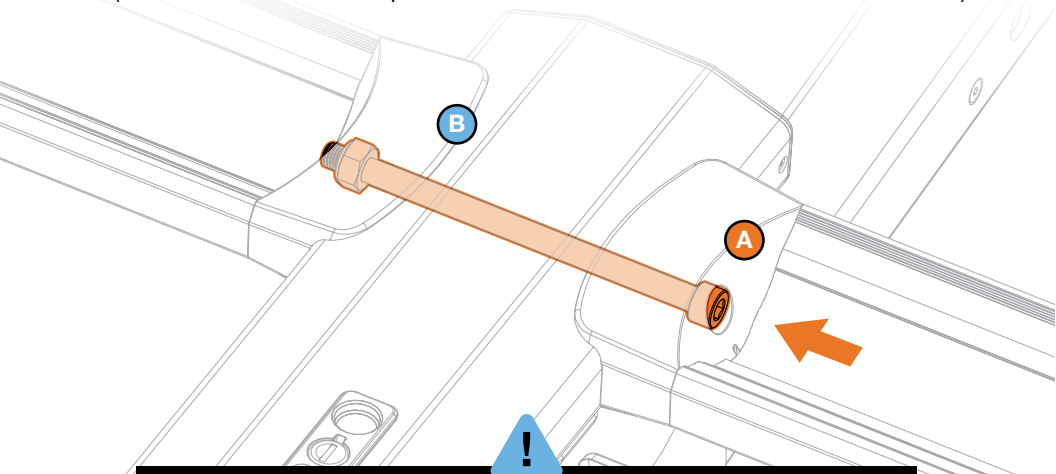

It may be necessary to lift **B** tray slightly to align bolt holes. Holding **B** tray M10 nut in place helps to ensure it stays secured during M10x165 installation and initial tightening.

Tray Assembly - Part 2

- 1 Connect C tray wiring harnesses to centerbeam.

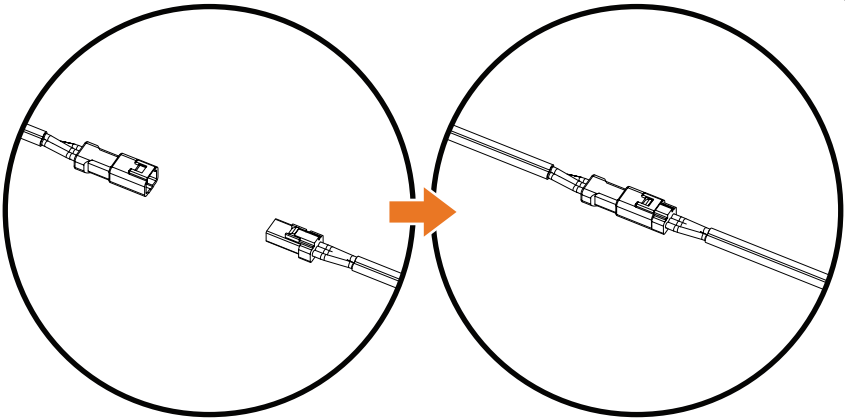
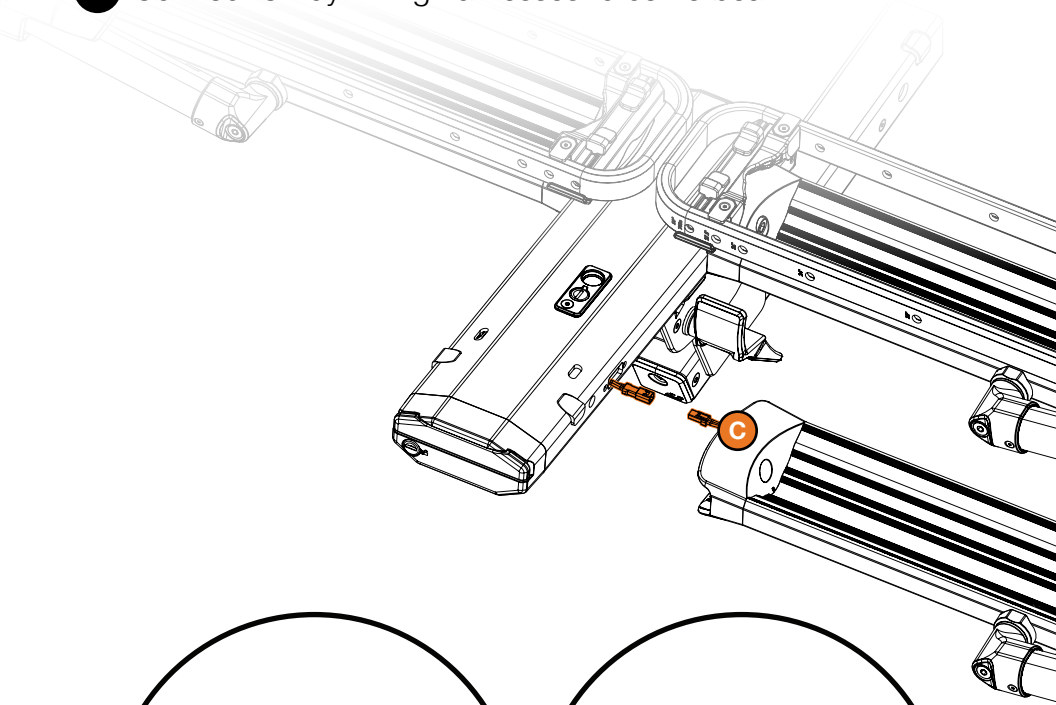

- 2 With wiring connected, hook labeled **C** tray to **C** position on centerbeam.



Feed excess wiring into centerbeam to avoid interference.

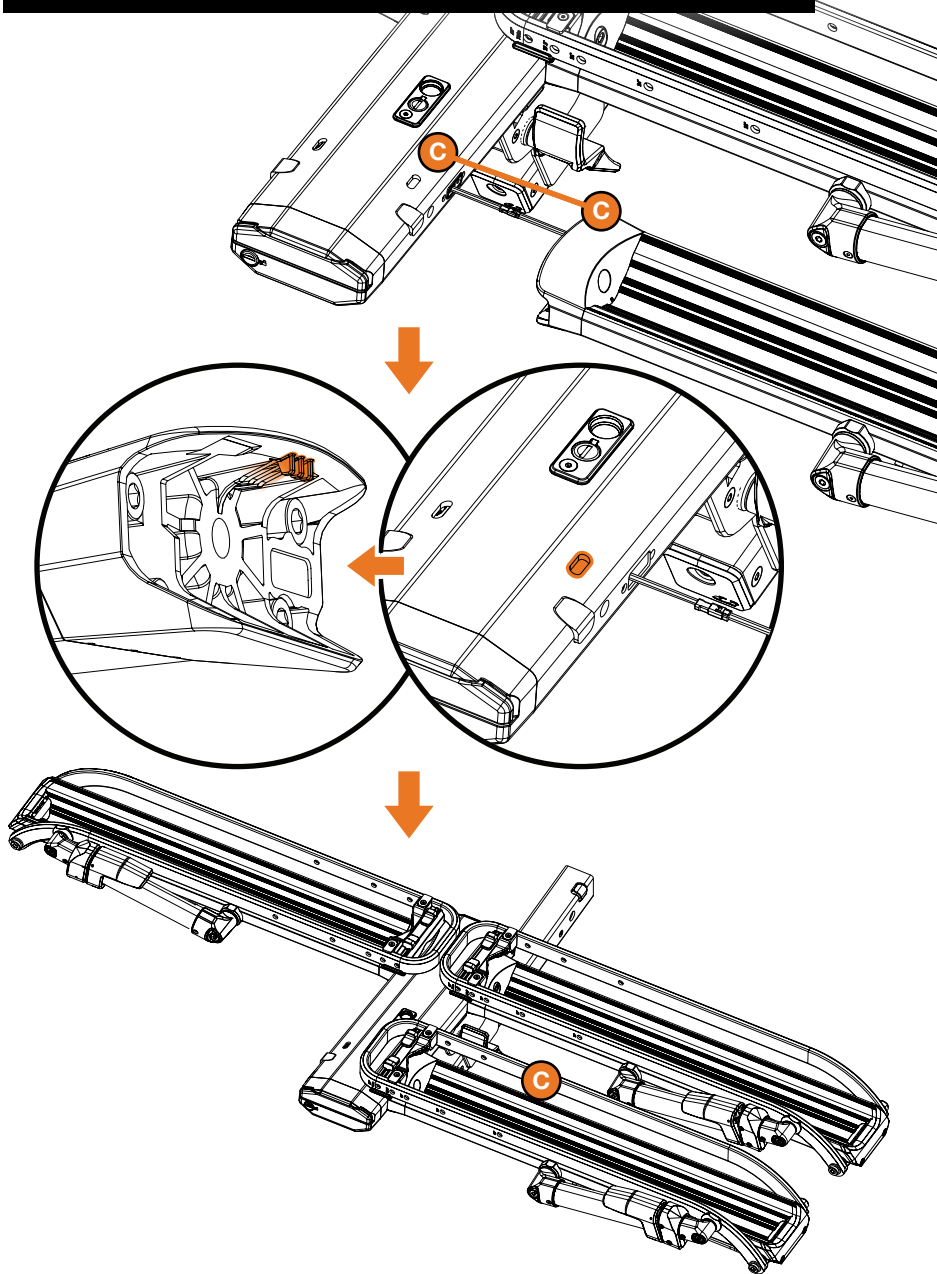

3 Connect D tray wiring harnesses to centerbeam.

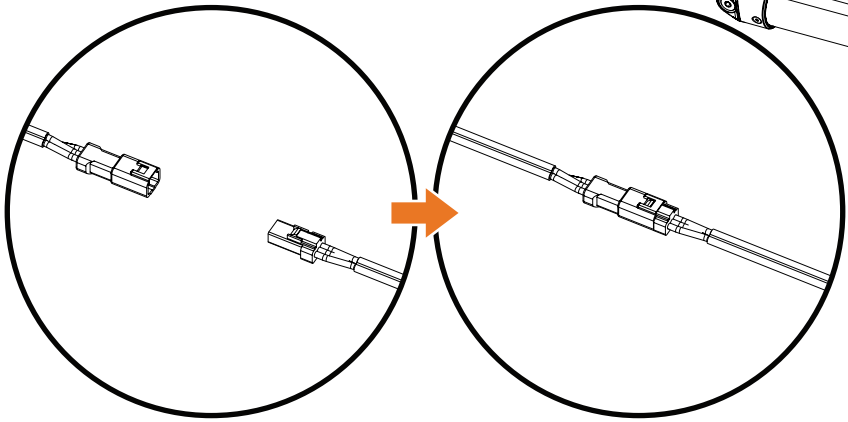
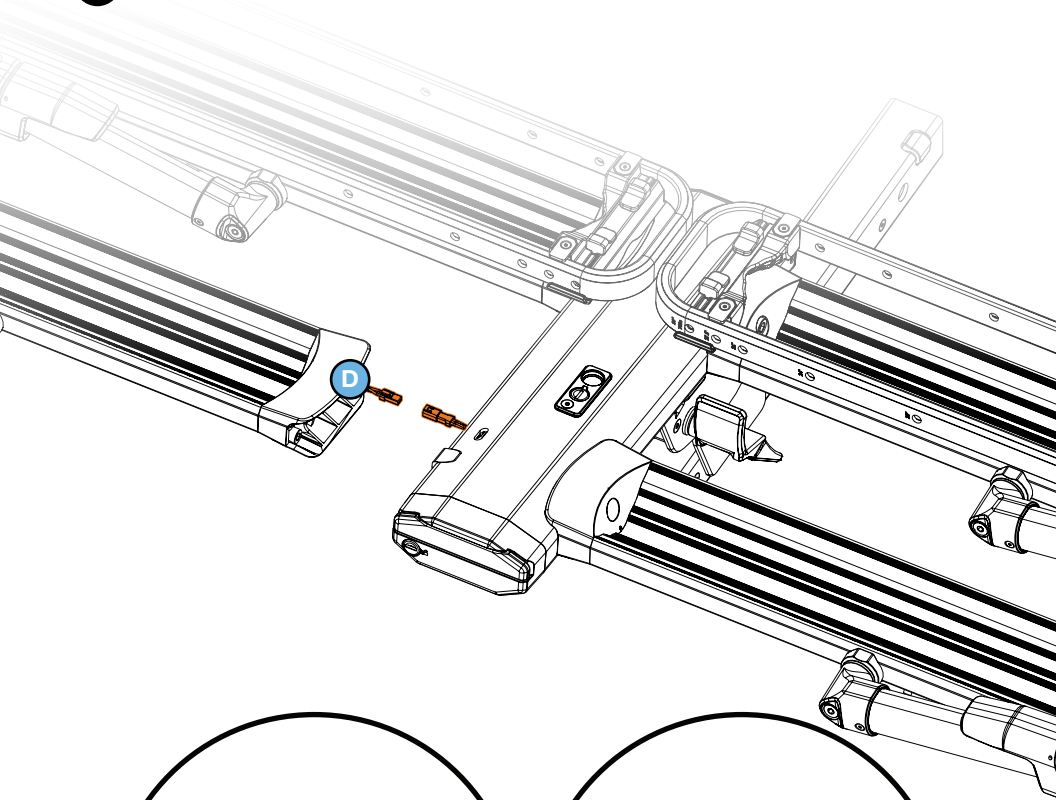

- 4 With wiring connected, hook labeled **D** tray to **D** position on centerbeam.



Feed excess wiring into centerbeam to avoid interference.

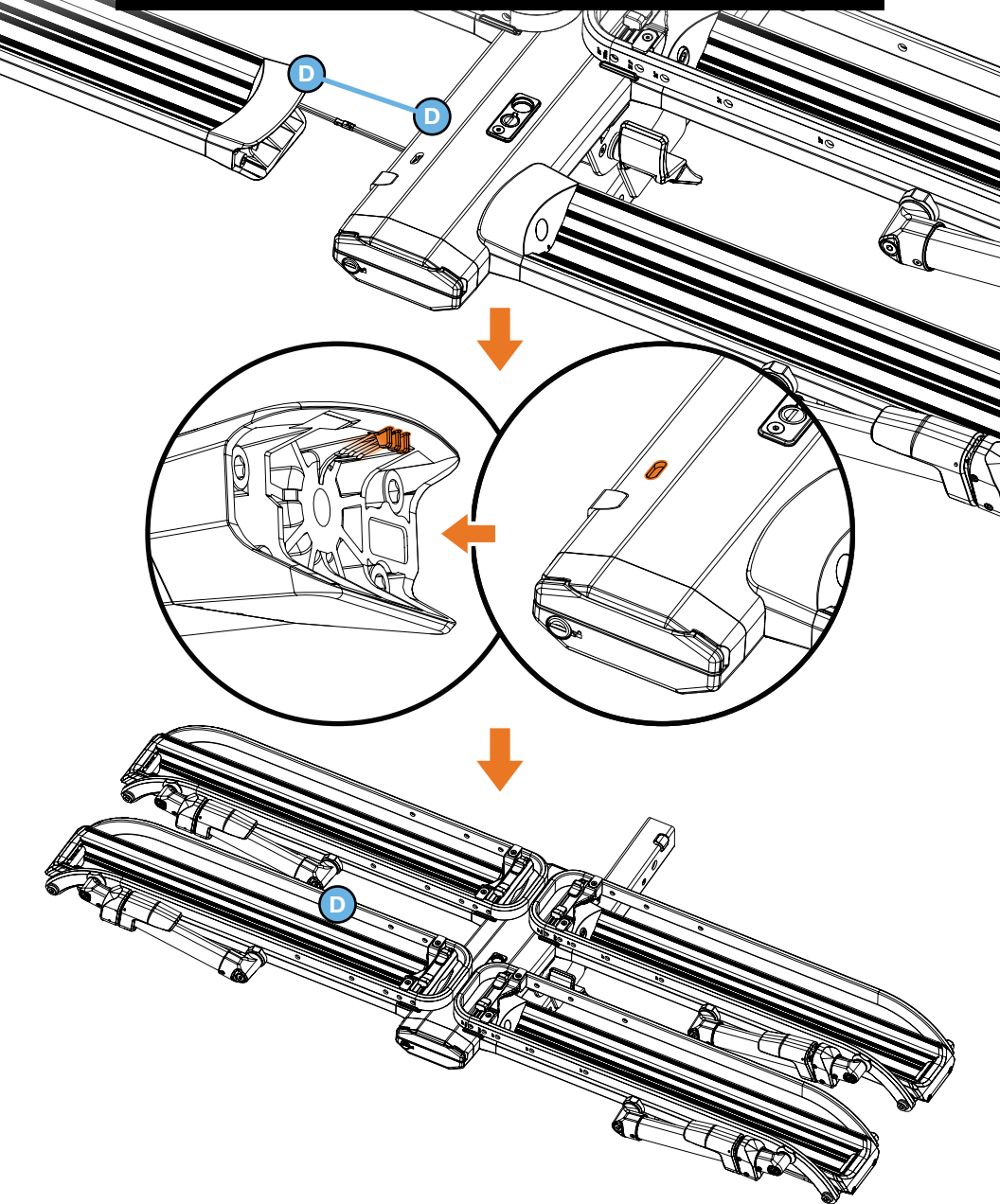

- 5 Opening Piston® arms provides easier access to tray bolt and tray nut locations.
- 6 With **C** and **D** trays secured, insert M10 nut into **D** tray.

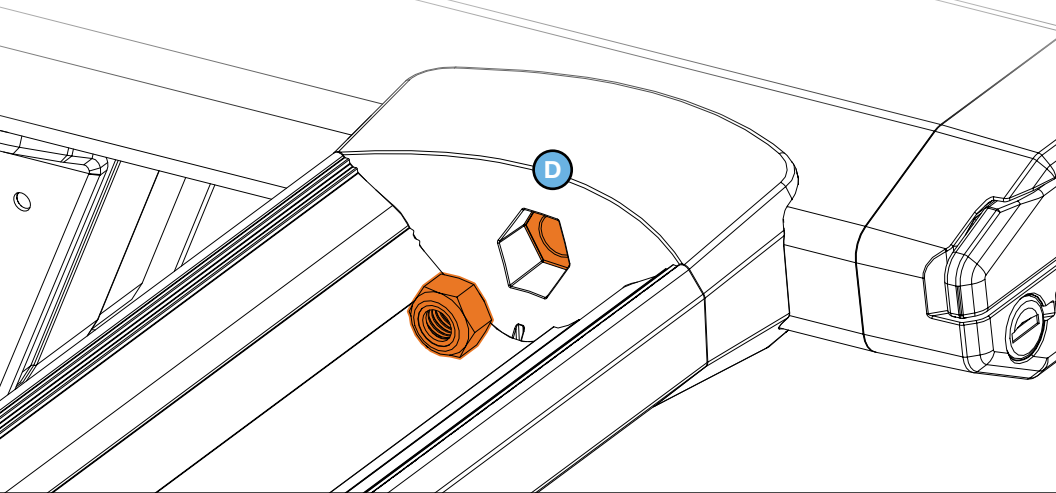

- 7 With M10 nut in place, insert M10x165 into **C** tray, through centerbeam, and into M10 nut. Tighten with 8mm hex key. (Recommended torque to **40-50Nm - Do not exceed 50Nm**)

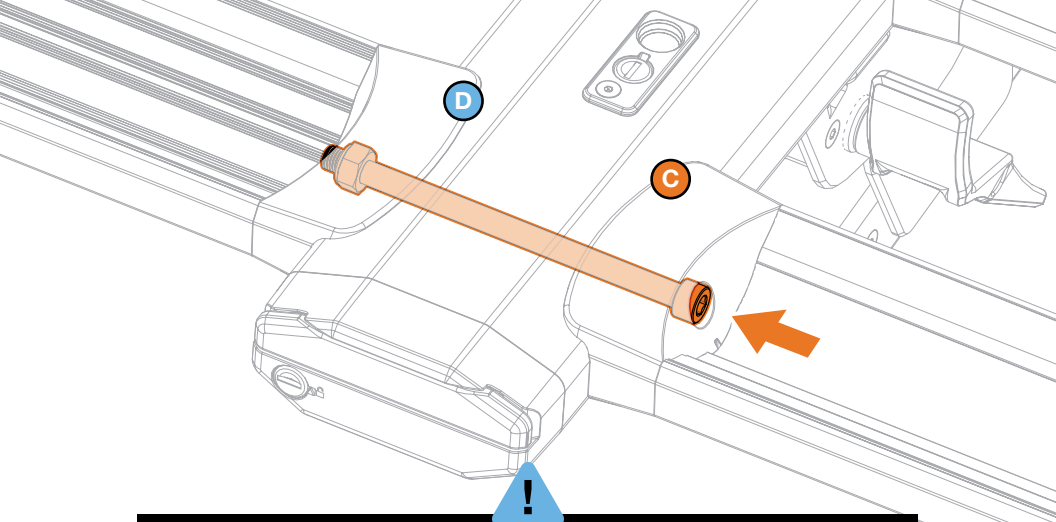

It may be necessary to lift **D** tray slightly to align bolt holes. Holding **D** tray M10 nut in place helps to ensure it stays secured during M10x165 installation and initial tightening.

Attaching / Detaching Assembled Rack

- 1 Insert Piston® into hitch receiver.

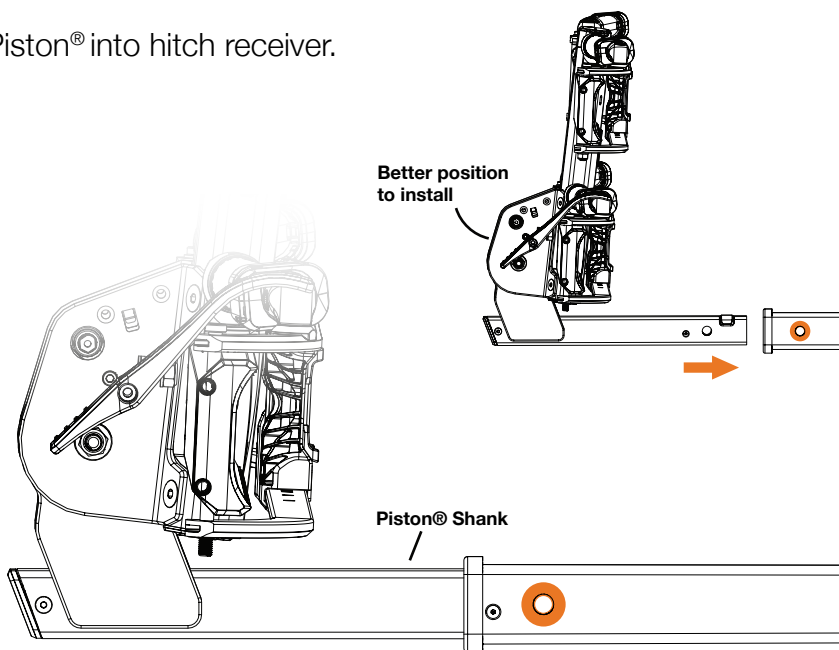

- 2 Align hitch pin holes.

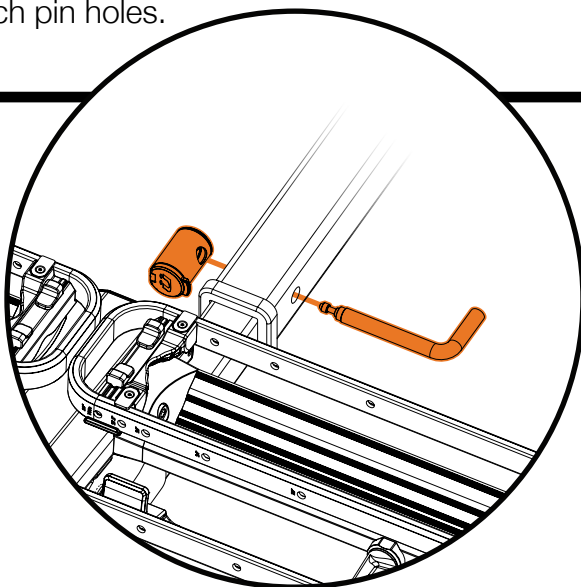

- 3 Insert hitch pin through holes in hitch receiver and Piston® shank, and secure with hitch pin lock.

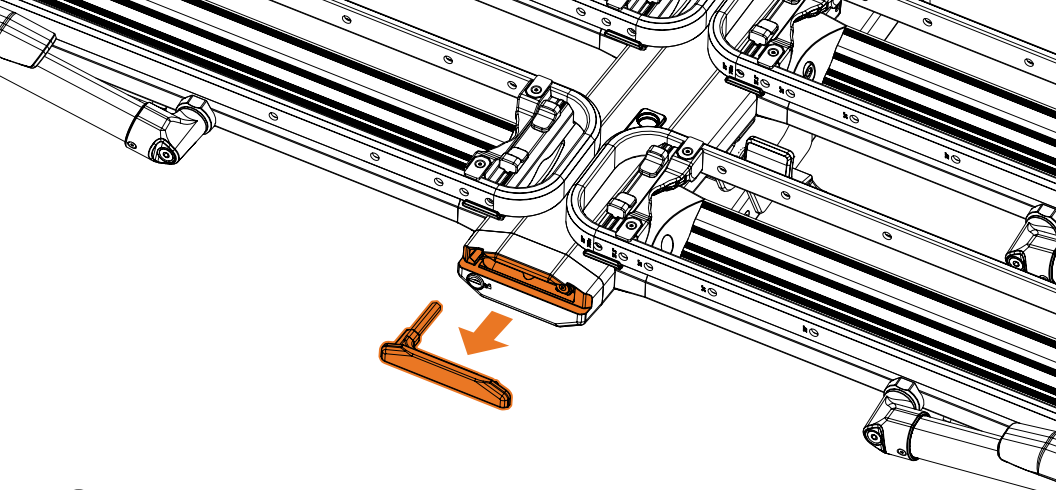

4 Unlock and remove the 8mm security hex key found at the front of the centerbeam.

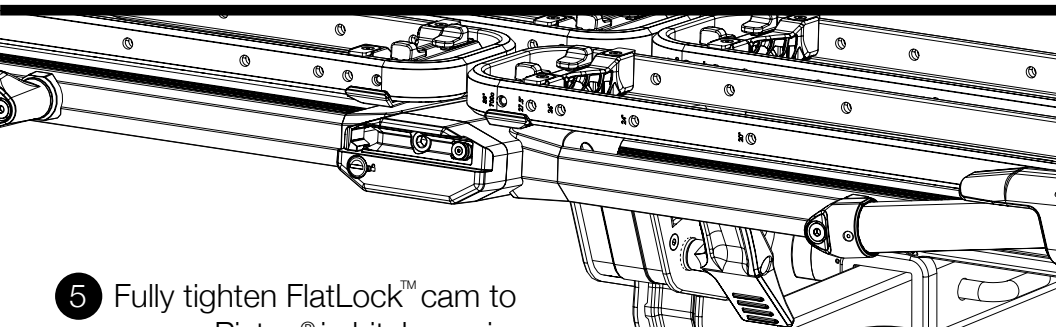

5 Fully tighten FlatLock™ cam to secure Piston® in hitch receiver. (Do not exceed 30 Nm)

! Remember to reinstall and secure security hex key with key.

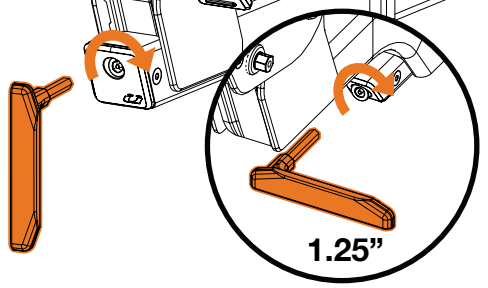

LED Light Installation

- 1 Locate flat 4-pin cable in your provided parts bag.
 - 2 Plug flat 4-pin into trailer light socket on your vehicle.
- !** Your trailer light socket may differ from the model shown - an adapter may be required.
- 3 Plug vehicle flat 4-pin cable into the flat 4-pin dongle located at the back of the Piston® Pro X centerbeam.

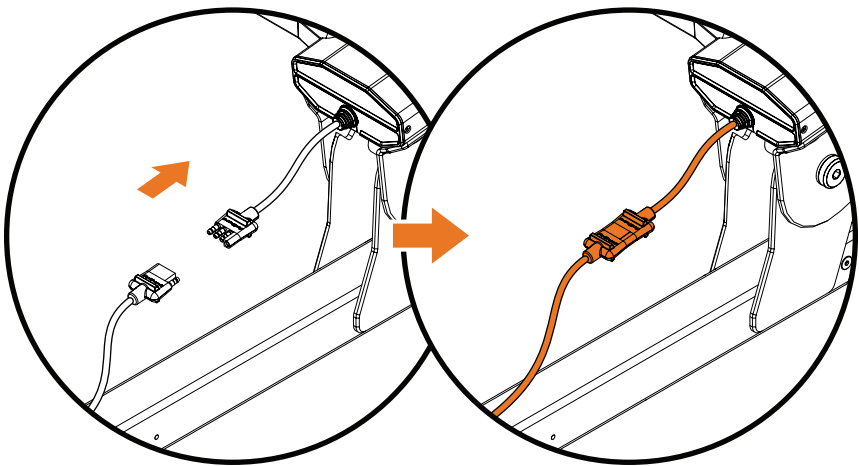

- 4 Perform a test for LED illumination and brake function as well as left and right blinker operation.

! LED lights are inspected and tested prior to packaging. Troubleshoot any issues with your vehicle connections or fuses by visiting kuat.com/piston/led



WARNING

The Piston® Pro X lights are only compatible with 12v electrical systems. Other voltages may damage the LED lights.

Cable Management

- 1 Locate (2) magnetic clips in your provided parts bag.

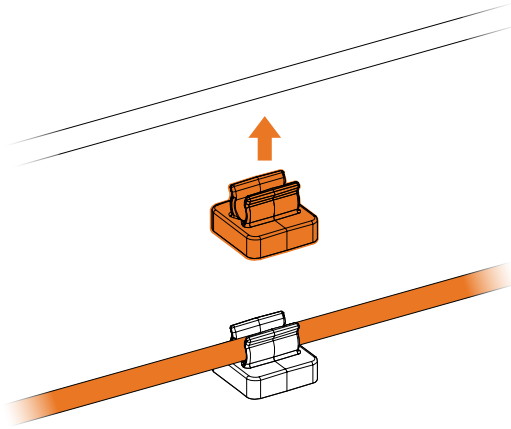

- 2 Place magnets along cable and snap them to the hitch shank and vehicle hitch.

Feel free to adjust magnetic clips up or down the cable to achieve a fit that works best for your setup.

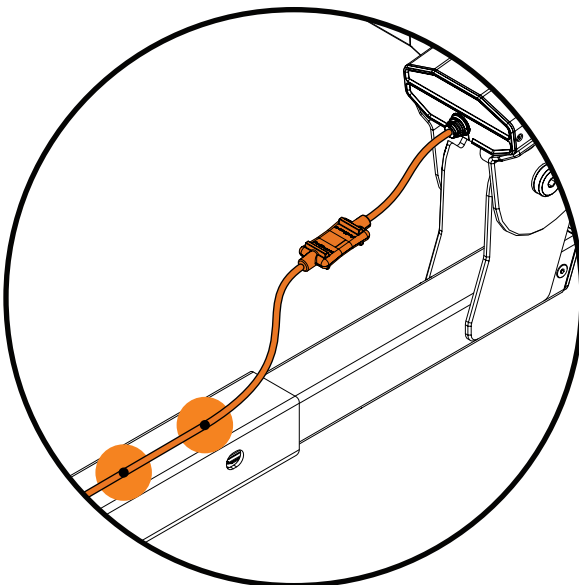

OneTap™ Operation

- 1 Open each arm by tapping the OneTap™ levers. Stand back and watch! Each arm will fully open automatically. **Do not hold the lever while opening or closing.**

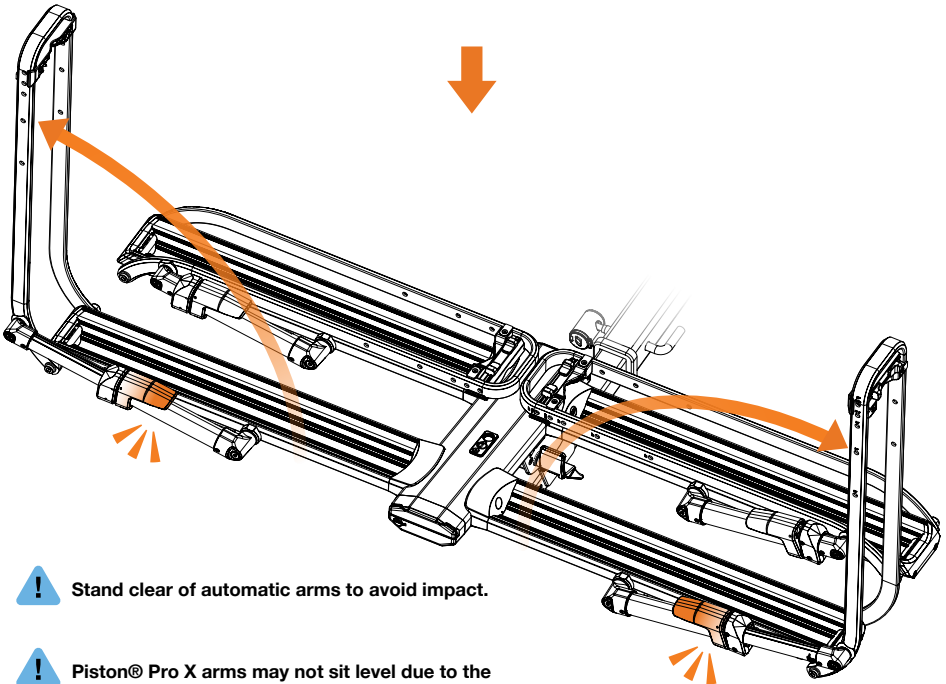
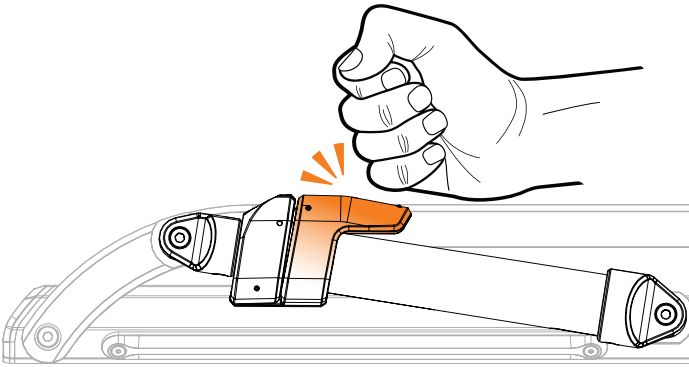

! Stand clear of automatic arms to avoid impact.

! Piston® Pro X arms may not sit level due to the back pressure on the piston strut. This is the nature of the design and does not affect the function of the rack.

- 2 To close, simply push arms back down into stowed position.

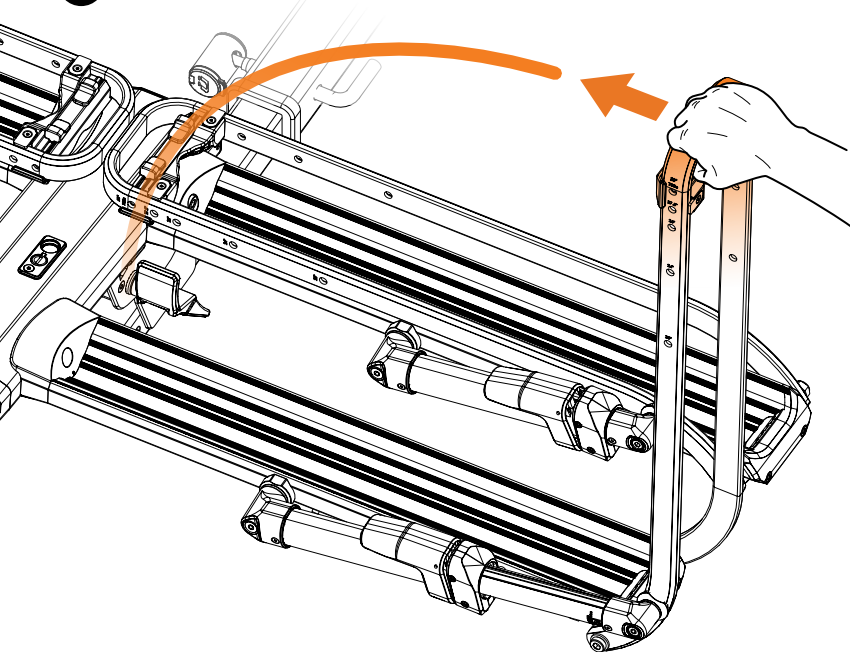

Foot Lever Operation

- 1 Fold rack up and down using the pivot lever.

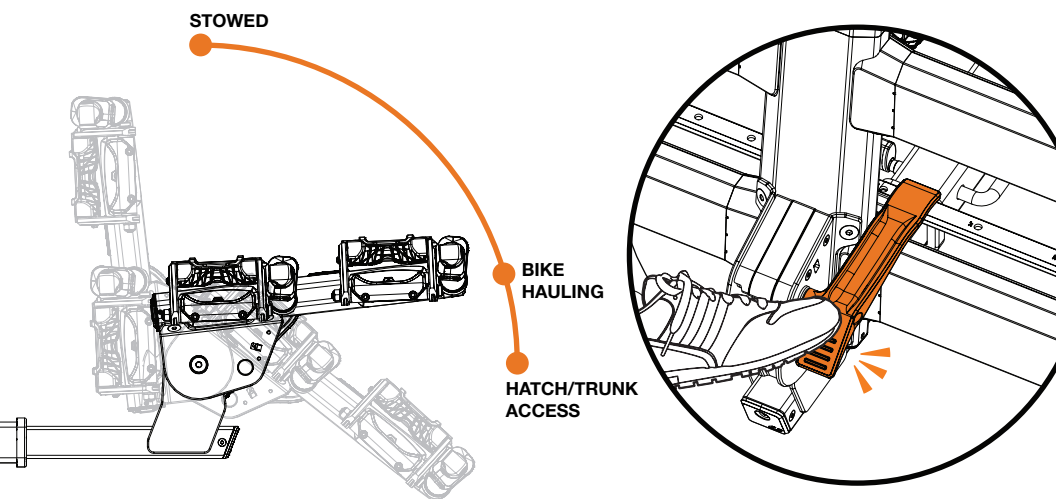

! When your rack is in the Stowed position, please ensure that your rack will not come into contact with your bumper.

Loading | Unloading Bikes

- 1 Push tabs inward and slide tire cradle up or down tire arm to adjust for measured wheel size.

! How to measure wheel.

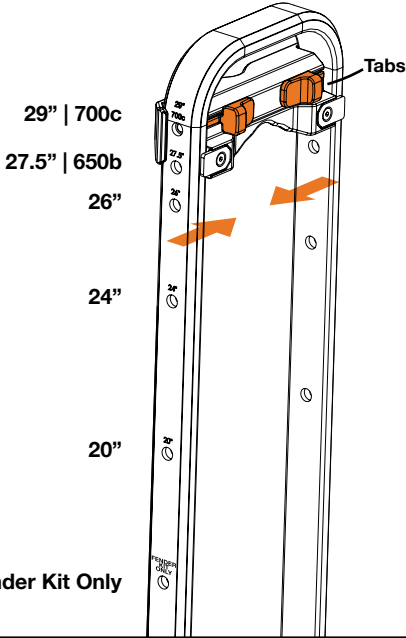
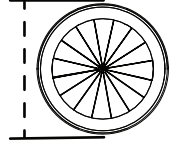

! Scan QR to order Fender Kit or visit <http://kuat.com/px2/fk>



- 2 Visually ensure tabs are fully secured in notches. Misaligned tabs or tabs not fully secured will show a red warning indicator.

! Failure to secure both tabs may result in bikes becoming loose and falling during travel.

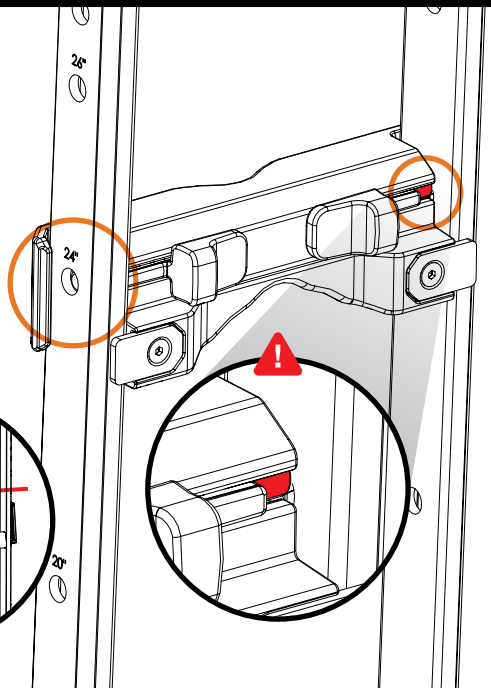
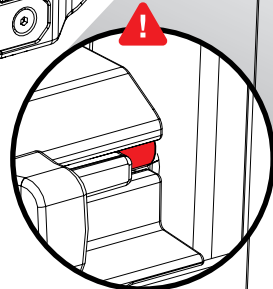
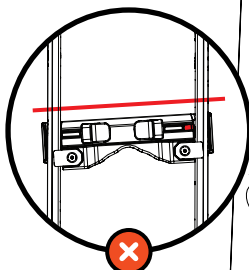
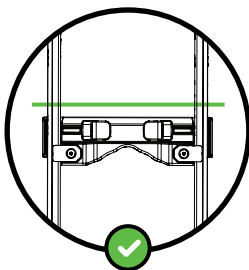

- 3 Open Piston® tire cradle arms by tapping each OneTap™ lever.

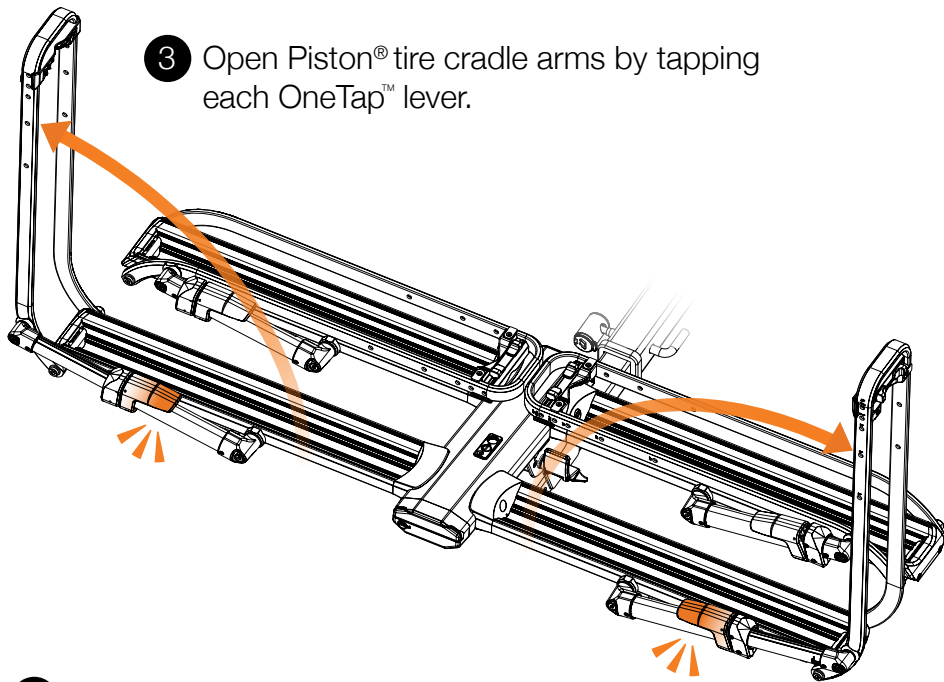

- 4 With bike in position close arms onto tires until firm contact is made with tire cradles.

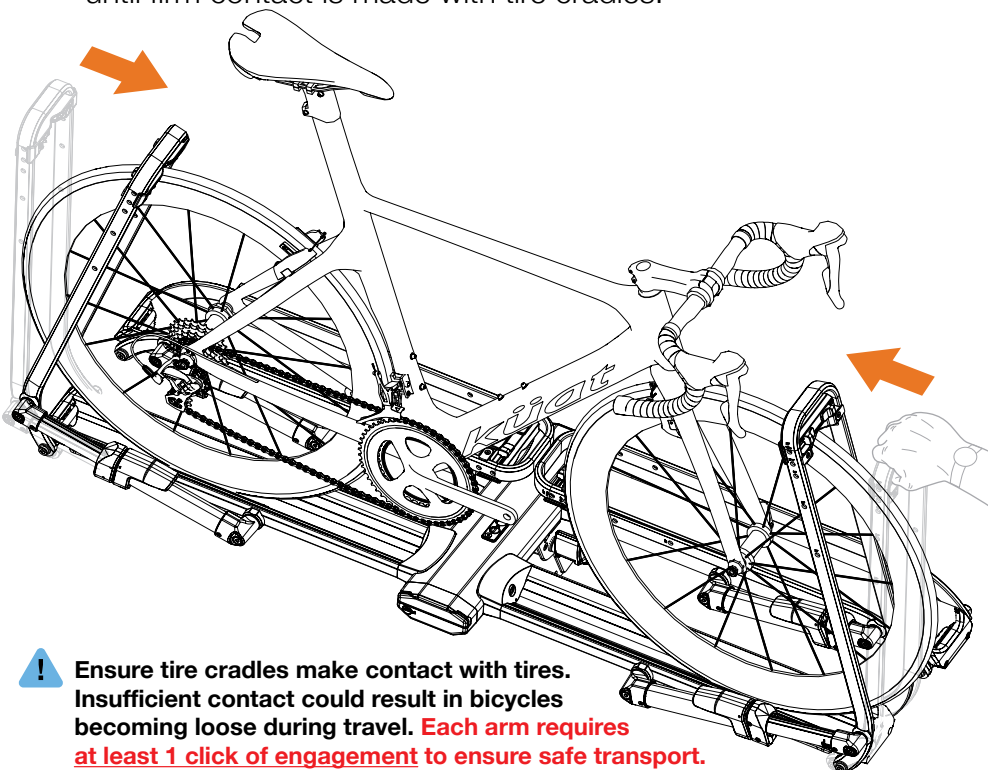

! Ensure tire cradles make contact with tires. Insufficient contact could result in bicycles becoming loose during travel. **Each arm requires at least 1 click of engagement to ensure safe transport.**

- 5 Should the need arise, bikes can be loaded asymmetrically, or oriented in the same direction to accommodate different fitment problems.

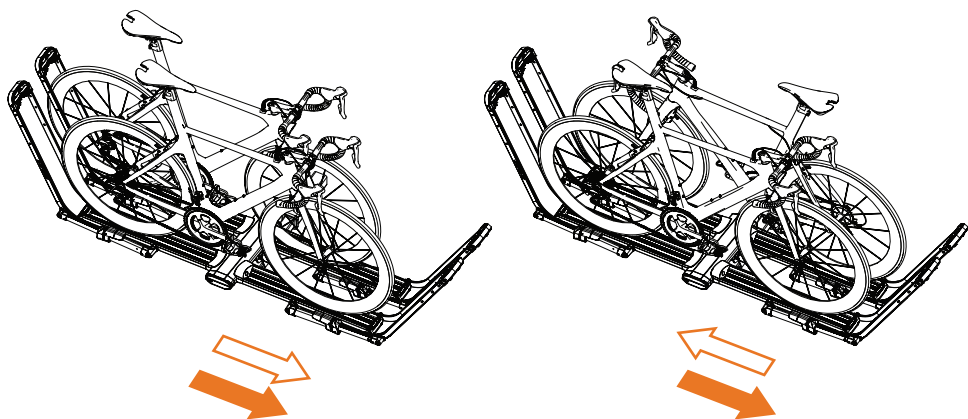

- 6 To further fine tune the fitment, bikes can be adjusted left and right on their individual trays.

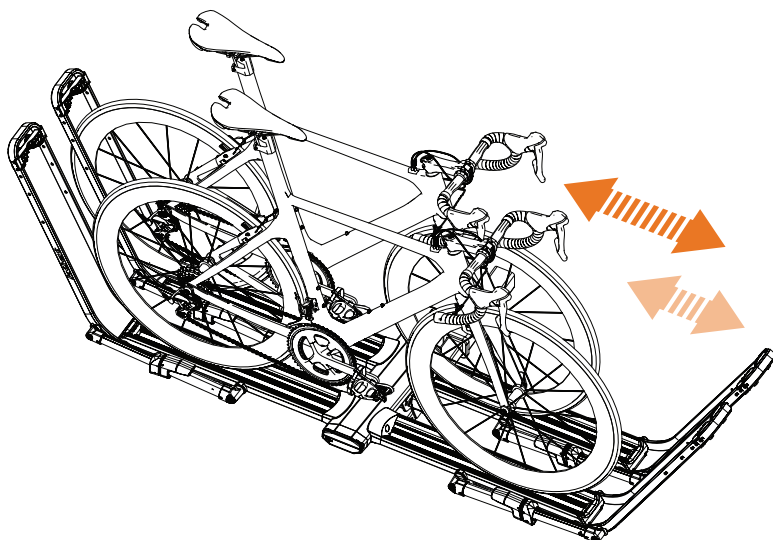

! Ensure tire cradles make contact with tires. Insufficient contact could result in bicycles becoming loose during travel.
Each arm requires at least 1 click of engagement to ensure safe transport.

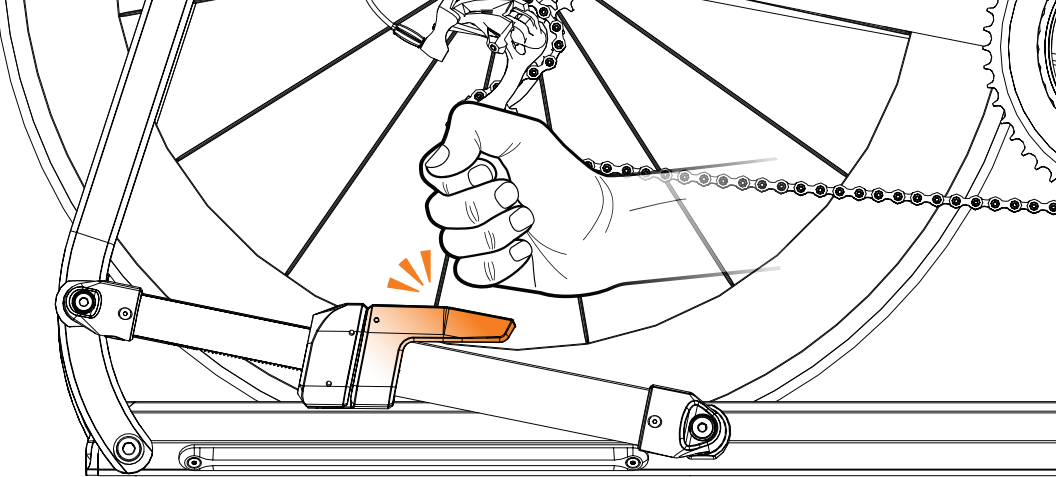

- 7 Tap each OneTap™ lever to release tire arms and unload bike.

! After pushing the OneTap™ lever, it may be necessary to push the tire arm up off the tire. Always keep one hand on bike when releasing tire arms.

Securing Your Bikes with Cable Lock

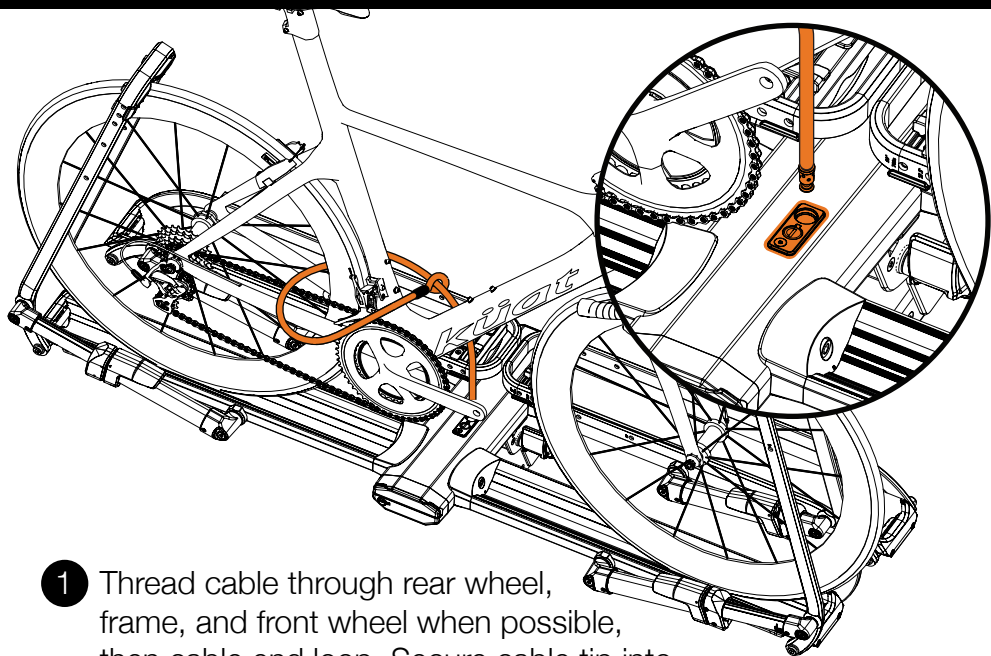

- 1 Thread cable through rear wheel, frame, and front wheel when possible, then cable end loop. Secure cable tip into lock port located on Piston® centerbeam.

eBike Ramp | Selective Bike Unloading

(Sold Separately)

The Piston® OneTap™ system allows users to rotate tire arms into a negative position for the installation of the Piston® eBike Ramp, or conveniently unload a bike in tray 2 without needing to unload tray 1.

To Fold Down

1 Tap OneTap™ lever to open tire arm.

2 Pull arm down into negative position.

! Do not hold OneTap™ lever while pulling arm into negative position.

3 Unload selected bike or install eBike Ramp.
(Sold Separately)

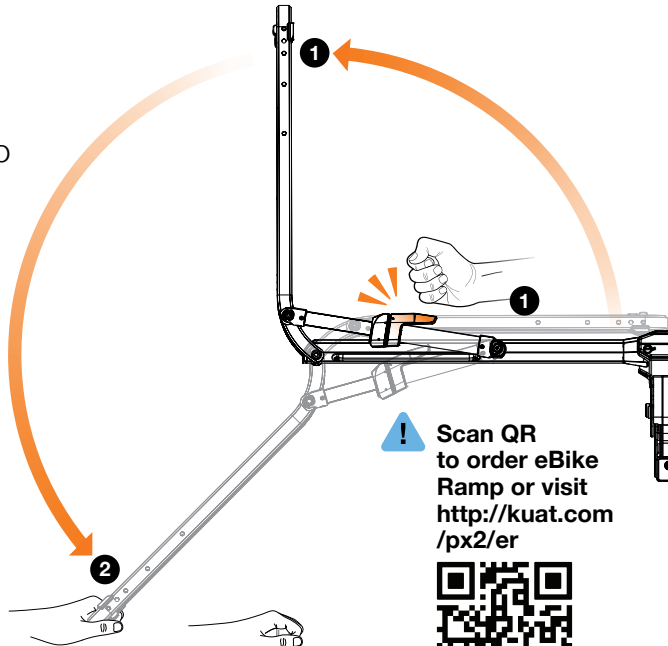

To Fold Up

1 Tap OneTap™ lever to release ratchet tension.

2 Pull tire arm back up into towing, or stowed position.

! Do not hold OneTap™ lever while moving arm into position.

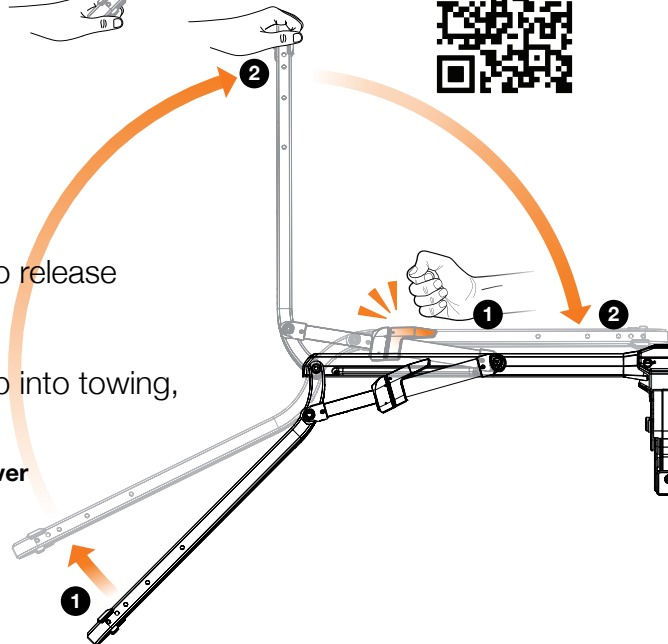

Warnings

PISTON® PRO X

Number Of Bikes

2

Weight Per Bike
Dedicated 2" Hitch

67 lb

30.4kg

Weight Per Bike
RV use(2" only)

42 lb

19kg

See RV
Compatibility
Warning

Weight Per Bike
1.25" Hitch Version

60 lb

27.2kg

No RV use

Max Wheelbase

53 in

1346 mm

See Piston®
Fender Kit
Fit Guide

Max Tire Width

5 in

127 mm

WARNINGS

- Follow instructions for proper assembly, installation and use.
- Check tightness of all bolts and screws periodically.
- Make sure rack and vehicle receiver are in working condition before each use.
- The Piston® Pro X lights are only compatible with 12v electrical systems. Other voltages may damage the LED lights.
- Only use hitch extenders with a tightening mechanism like Küat hitch extenders.
- Do not use bicycle fenders or cargo racks with this product without Piston® Fender Kit.
-Wheelbase reduces with fenders. See fit guide.
- Do not use bicycle or weight limits intended for this rack.
- Do not use rack off road (rough, washed out, boulder-and-rut-strewn backroads).
-Smooth gravel roads are not considered off-road.
- Do not use tarps, rain covers or wind covers with this product.
- Do not take through automatic car wash.
- Read the Limited Warranty for additional limitations on use with RV's and hitch extender products.
- Drive responsibly.

ADVERTENCIAS

- Siga las instrucciones para un montaje, instalación y uso adecuados.
- Verifique periódicamente el apriete de todos los pernos y tornillos.
- Asegúrese de que el portaequipajes y el receptor del vehículo estén en buenas condiciones antes de cada uso.
- Las luces Piston® Pro X solo son compatibles con sistemas eléctricos de 12v. Otros voltajes pueden dañar las luces LED.
- Utilice únicamente extensores de enganche con un mecanismo de apriete como los extensores de enganche Küat.
- No use guardabarros de bicicleta o soportes de carga con este producto sin el kit de guardabarros Piston®.
-La distancia entre ejes se reduce con guardabarros. Consulte la guía de ajuste.
- No exceda los límites de bicicleta o peso previstos para este portabicicletas.
- No utilice la rejilla fuera de la carretera (carreteras secundarias irregulares, arrasadas, llenas de cantos rodados y surcos).
-Los caminos de ripio liso no se consideran fuera de la carretera.
- No use lonas, cubiertas para la lluvia o cubiertas contra el viento con este producto.
- No pase por lavado automático de autos.
- Lea la Garantía limitada para conocer limitaciones adicionales sobre el uso con productos de extensión de enganche y vehículos recreativos.
- Conduzca con responsabilidad.

AVERTISSEMENTS

- Suivez les instructions pour un assemblage, une installation et une utilisation appropriés.
- Vérifiez périodiquement le serrage de tous les boulons et vis.
- Assurez-vous que le porte-bagages et le récepteur du véhicule sont en bon état de fonctionnement avant chaque utilisation.
- Les lampes Piston® Pro X ne sont compatibles qu'avec les systèmes électriques 12v. D'autres tensions peuvent endommager les lumières LED.
- Utilisez uniquement des rallonges d'attelage avec un mécanisme de serrage comme les rallonges d'attelage Küat.
- N'utilisez pas de garde-boue de vélo ou de porte-bagages avec ce produit sans le kit de garde-boue Piston®.
- Empattement réduit avec les ailes. Voir le guide d'ajustement.
- Ne dépassez pas les limites de vélo ou de poids prévues pour ce porte-bagages.
- N'utilisez pas de crémaillère hors route (routes secondaires accidentées, délavées, parsemées de rochers et d'ornières).
-Les routes en gravier lisse ne sont pas considérées comme hors route.
- N'utilisez pas de bâches, de housses de pluie ou de housses contre le vent avec ce produit.
- Ne passez pas dans un lave-auto automatique.
- Lisez la garantie limitée pour connaître les limitations supplémentaires sur l'utilisation avec les produits de VR et

LIMITED WARRANTY

We stand behind our products, and our customer service reps are waiting to help you out if you have any problems with your product. Our limited warranty covers your purchase for life. You can review our limited warranty on our website or call customer service at the number below if you have questions or need a repair, replacement, refund, or a copy of the limited warranty.

www.kuat.com/warranty

Questions or comments?

Drop us an email or call us directly!

kuat.com | info@kuat.com | [877.822.5828](tel:877.822.5828)

Küat RV Compatibility Warning

Küat's receiver hitch-mounted bicycle racks may be used with some recreational vehicles (RVs) as described below. Many types of RVs subject the rack and bicycles on it to high forces and extreme movements. As a result, Küat does not recommend using our receiver hitch-mounted products on RVs that will likely expose the rack to unacceptable conditions.

Küat's standard warranty will cover use of any of its 2-inch receiver hitch-mounted bicycle racks on motorhomes (as defined in 49 C.F.R. 571.3) satisfying all of the following requirements:

- 1) The receiver hitch is directly attached to the motorhome chassis, not just to the bumper;
- 2) The rear-most point of the receiver hitch where the bicycle rack will be attached is no more than 64 inches from the rear axle of the motorhome; and
- 3) The vehicle is a class B type motorhome as described below.

Class B type motorhomes are commonly known as van conversions and comprise a completed van-type vehicle which has been altered to provide temporary living quarters. Class B type motorhomes have a gross vehicle weight rating of 10,000 lbs or less.

In addition, (i) the 2 inch receiver Transfer™ v2, (ii) the 2-inch receiver Piston® Pro X, and (iii) the Piston® SR with 2" Hitch Adapter may be used on RVs (both motorhomes and trailers) satisfying all of the following requirements:

- 1) The receiver hitch is directly attached to the RV chassis, not just to the bumper; and
- 2) The bicycle rack is in the 2-bike configuration with no add-on unit attached.

Please check the Warnings section of the User Guide for load weight limits applicable to your rack when used on an RV. Lower weight limits apply.

Even if the conditions above are met, any RV may be operated in a way that will expose Küat's products to conditions that they are not designed to handle. The operator of the RV is responsible to operate the RV in a manner that will not overload the rack, such as by excessive speed over rough roads or speed bumps, rapid turning movements, driving the RV over changes in gradient that will bring the rack in contact with the ground, or other similar actions.

kuat[®]

1.877.822.5828

info@kuat.com

kuat.com